



Standard Practice for Bulk Sampling of Liquid Uranium Hexafluoride¹

This standard is issued under the fixed designation C 1052; the number immediately following the designation indicates the year of original adoption or, in the case of revision, the year of last revision. A number in parentheses indicates the year of last reapproval. A superscript epsilon (ϵ) indicates an editorial change since the last revision or reapproval.

1. Scope

1.1 This practice covers methods for withdrawing representative samples of liquid uranium hexafluoride (UF_6) from bulk quantities of the material. Such samples are used for determining compliance with the applicable commercial specification, for example Specification C 787 and Specification C 996.

1.2 It is assumed that the bulk liquid UF_6 being sampled comprises a single quality and quantity of material. This practice does not address any special additional arrangements that might be required for taking proportional or composite samples, or when the sampled bulk material is being added to UF_6 residues already in a container (“heels recycle”).

1.3 The number of samples to be taken, their nominal sample weight, and their disposition shall be agreed upon between the parties.

1.4 The scope of this practice does not include provisions for preventing criticality incidents.

1.5 *This standard does not purport to address all of the safety concerns, if any, associated with its use. It is the responsibility of the user of this standard to establish appropriate safety and health practices and determine the applicability of regulatory limitations prior to use.*

2. Referenced Documents

2.1 ASTM Standards:²

C 787 Specification for Uranium Hexafluoride for Enrichment

C 996 Specification for Uranium Hexafluoride Enriched to Less Than 5 % ²³⁵U

2.2 Other Documents:

USEC-651 Uranium Hexafluoride: A Manual of Good Handling Practices³

ANSI N14.1 Uranium Hexafluoride: Packaging for Transport⁴

ISO/DIS 7195 Packaging of Uranium Hexafluoride (UF_6) for Transport⁴

3. Terminology

3.1 Definitions of Terms Specific to This Standard:

3.1.1 *container*—the bulk vessel either holding or receiving by transfer, the UF_6 to be sampled; it may consist of, for example, a fixed vessel in a UF_6 handling plant or a cylinder to be used for the transport of UF_6 .

3.1.2 *sample bottle*—the small vessel into which the sample of UF_6 is withdrawn for transfer to the laboratory for characterization.

4. Summary of Practice

4.1 Two methods of withdrawing a sample are described, namely: (1) direct withdrawal from a filled container and (2) withdrawal from the inlet-line during the filling of a container by liquid transfer. The first method involves tilting or turning the container in such a way that its valve is below the surface of the liquefied UF_6 , and dependent on the equipment, this requires that the container holds more than a specified minimum quantity of UF_6 . Liquid UF_6 is withdrawn into a graduated volume and then transferred to the respective sample bottle(s). In the second method, a small proportion of the UF_6 flowing from one container to another is withdrawn into a graduated volume and then transferred to the respective sample bottle(s).

4.2 For both methods of sampling, the presence of residues may have significant implications for the quality of the UF_6 . For safety and quality reasons, containers and bottles shall be clean, dry, and empty before filling.

4.3 Various types of sample bottles are in use and are described in detail in the applicable national and international standards, for example, ANSI N14.1 and ISO/DIS 7195. For a given type of sample bottle, the detailed configuration, for example, valve orientation, terminal fittings, and the like, may

¹ This practice is under the jurisdiction of ASTM Committee C26 on Nuclear Fuel Cycle and is the direct responsibility of Subcommittee C26.02 on Fuel and Fertile Material Specifications.

Current edition approved June 1, 2007. Published July 2007. Originally approved in 1985. Last previous edition approved in 2001 as C 1052 – 01.

² For referenced ASTM standards, visit the ASTM website, www.astm.org, or contact ASTM Customer Service at service@astm.org. For Annual Book of ASTM Standards volume information, refer to the standard's Document Summary page on the ASTM website.

³ Available from United States Enrichment Corp., 6903 Rockledge Dr., Bethesda, MD 20817.

⁴ Available from American National Standards Institute, 11 W. 42nd St., 13th Floor, New York, NY 10036.

vary. Hence, the type and configuration of bottles to be used for the withdrawal of samples shall be agreed upon between the parties.

5. Significance and Use

5.1 Uranium hexafluoride is normally produced and handled in large (typically 1- to 14-ton) quantities and must, therefore, be characterized by reference to representative samples. The quantities involved, physical properties, chemical reactivity, and hazardous nature of UF₆ are such that for representative sampling, specially designed equipment must be used and operated in accordance with the most carefully controlled and stringent procedures. This practice indicates appropriate principles, equipment, and procedures currently in use for bulk sampling of liquid UF₆. It is used by UF₆ converters, enrichers, and fuel fabricators to review the effectiveness of existing procedures or as a guide to the design of equipment and procedures for future use. Other sampling procedures such as UF₆ vapor sampling are not directly representative of the quality of liquid UF₆.

5.2 It is emphasized that this practice is not meant to address conventional or nuclear criticality safety issues.

6. Hazards

6.1 Because of its chemical, radiochemical, and toxic properties, UF₆ is a hazardous material. Suitable handling procedures are described in USEC-651.

7. Principles

7.1 The essential purpose of the sample is to be representative of the bulk material for the purpose of determining compliance with the applicable material specification. To ensure that the sample is representative for this purpose, certain principles, as described below, must be observed.

7.2 Special attention must be given to ensuring that the bulk material from which the sample is withdrawn is homogeneous, particularly in those circumstances when it has been prepared by the blending together of materials having different compositions. In practice, the low viscosity, and hence easy mobility, of liquid UF₆ facilitates the process of homogenization by the action of convection currents within the bulk upon heating. It is necessary to determine and establish for each set of sampling equipment the physical conditions, normally a combination of the minimum time and temperature for which liquefied uranium hexafluoride is held, which guarantee homogeneity of the bulk UF₆.

7.3 Uranium hexafluoride is very reactive and corrosive. It reacts readily with water, atmospheric moisture, certain metals, and many organic materials. For reasons of safety and to avoid contamination, precautions must be taken to avoid contact with such materials. The sampling equipment is therefore fabricated to appropriate high standards of vacuum integrity, and components in direct contact with UF₆ are made from nickel, high-nickel alloys, or materials having equivalent resistance to UF₆ corrosion. The formation of an inert fluoride layer is often an important feature of UF₆ corrosion resistance, and hence, internal surfaces are generally conditioned with a suitable fluorinating agent, sometimes UF₆ itself.

7.4 Cross-contamination may occur between subsequent samples taken using the same equipment, and appropriate precautions must be taken to prevent this. It is therefore recommended that, before taking definitive samples, the equipment is flushed through with an aliquot of the material to be sampled. This is normally accomplished by taking an initial volume which is then rejected and not used for definitive analysis. Alternative procedures to prevent cross-contamination are possible and should be validated individually.

7.5 If the sample bottles are taken for an analytical need such as liquid UF₆ subsampling for P10 tubes or liquid UF₆ transfer for FTIR quantification, it is recommended, in order to minimize the gas phase contribution to the sample bottle, to fill the bottle with more than 10% of its total volume.

8. Procedure for Sampling Directly from Filled Containers (see Fig. 1)

8.1 The equipment consists of a sample manifold that is connected directly to the valve of the transport container and has facilities for connecting one or more sample bottles. The graduated volume is appropriately sized so that when filled either completely or visually to a predetermined level it will contain a known quantity of UF₆. The graduated volume may consist of the manifold and associated pipework, or may include an additional metering volume (pipette). The equipment may be designed to withdraw either single or multiple sample quantities of UF₆ at each operation. The total graduated volume of the connected equipment (excluding the vacuum system) should not exceed the designated maximum fill volume of the connected sample bottles. Certain valves may be remotely operated as necessary. The sampling equipment must be heated to prevent solidification of the UF₆ and may be located within the same heated enclosure as the container. The sample bottles may be heated separately to permit independent cooling, if necessary.

8.2 Load the container to be sampled into the heating enclosure (for example, autoclave) and attach the sampling equipment, including sample bottles. Evacuate and test the equipment to ensure vacuum integrity.

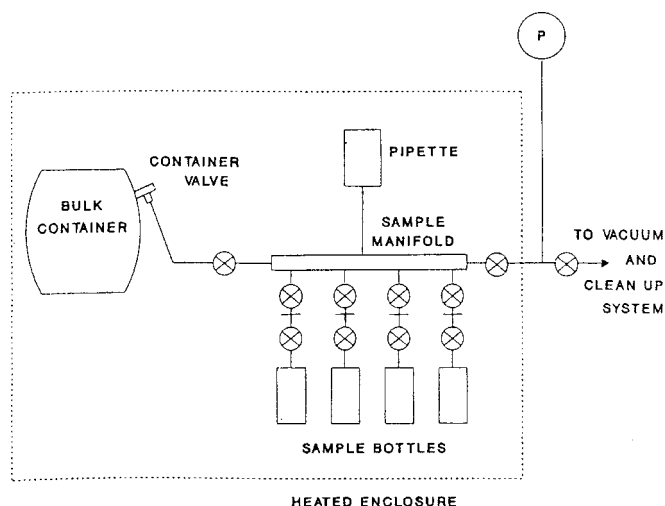

FIG. 1 Schematic Arrangement for Sampling Directly from a Filled Container

8.2.1 When local safety regulations permit, a container of hot, liquid UF₆ may be loaded into the sampling equipment and the sample bottles attached.

8.3 Heat the bulk UF₆ for a sufficient period to ensure homogeneity in accordance with the procedure established for the equipment (see 7.2). During heating, monitor and check the vapor pressure against the applicable pressure limit (if any) to ensure compliance with the relevant specification and maintenance of a safe pressure level. In case of overpressure, follow appropriate procedures.

8.4 When the conditions for homogeneity have been met, withdraw the appropriate quantity of liquid UF₆ into the graduated volume. This is usually effected by changing the position of the container in such a way, for example, by tilting or turning, that the UF₆ flows under the influence of gravity and any differential pressures established within the equipment. Restore the container to its original position leaving the graduated volume filled with liquid UF₆. This may be indicated by the use of suitable temperature sensors or pressure transducers or strain gages.

8.5 If the equipment is designed to withdraw a single sample at each operation, open the appropriate sample valve to allow the UF₆ to flow into the sample bottle. Isolate the sample bottle from the sampling manifold.

8.5.1 The first sample may be used to condition internal surfaces of the equipment (see 7.3) by suitable manipulation of the vacuum system or rejected to prevent cross-contamination from previously sampled materials or both (see 7.4).

8.5.2 Take successive samples by repeating steps 8.4 and 8.5 as necessary.

8.6 If the equipment is designed to withdraw multiple samples at each operation, transfer the samples to the sample bottles by operating the valves associated with the successive sample bottles in the appropriate sequence.

8.7 At the completion of sampling, close the container valve and evacuate the sampling equipment through the vacuum system to remove residual UF₆.

8.8 Fill the equipment to atmospheric pressure with dry gas and remove, identify, cap, and weigh the sample bottles. Local safety regulations may demand that the UF₆ is allowed to cool and solidify (below atmospheric pressure) before this operation is carried out.

9. Procedure for Sampling During Filling of Transport Containers (see Fig. 2)

9.1 The equipment consists of a sample manifold that has facilities for connecting one or more sample bottles and is connected to the filling manifold between the main and secondary (for example, transport) containers. The graduated volume is appropriately sized to contain the quantity of UF₆ required for a single sample and normally consists of the manifold and associated pipework itself or may include an additional metering volume (pipette). The total graduated volume of the connected equipment (excluding the vacuum system) should not exceed the designated maximum fill volume of the attached sample bottles. Certain valves may be remotely operated as necessary. Heat the sampling equipment to prevent the solidification of UF₆. The sample bottles may be

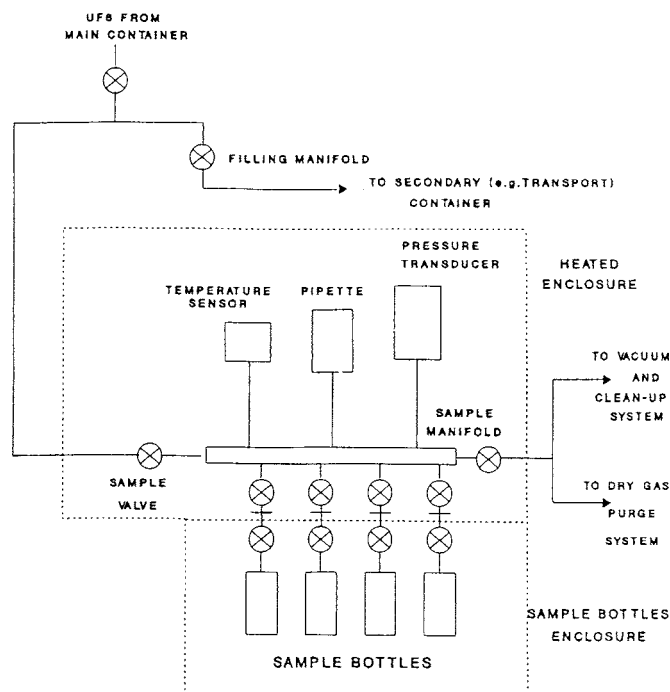

FIG. 2 Schematic Arrangement for Sampling During the Filling of a Transport Container

contained in a separate enclosure to permit independent cooling if necessary (see 9.6).

9.2 Conditions for homogeneity must be met within the UF₆ main container immediately before the run-off to the secondary (for example, transport) container (see 7.2). This main container may typically be a plant vessel (for example, condenser) or another larger transport container (mother-container). In case of the presence of particles in the UF₆, careful attention should be taken when choosing the appropriate time for sampling because of rapid sedimentation.

9.3 Attach the sampling equipment, including sample bottles, at the relevant location to the UF₆ runoff line. Evacuate and test the equipment to ensure vacuum integrity. Isolate the sample bottles from the sample manifold.

9.4 Establish liquid transfer of UF₆ from the main container to the secondary container.

9.5 At an appropriate time, open the sampling valve and withdraw the required quantity of UF₆ into the graduated volume. This may be indicated by the use of suitable temperature sensors or pressure transducers or strain gages.

9.6 Close the sampling valve and open the first sample bottle valve to transfer the sample. The equipment should be designed to allow transfers to take place using the influence of gravity and differential pressures induced by temperature gradients. For this purpose, it may be necessary to cool the receiving sample bottles.

9.6.1 The first sample may be used to condition internal surfaces of the equipment (see 7.3) by suitable manipulation of the vacuum system or rejected to prevent cross-contamination from earlier materials or both (see 7.4).

9.7 Isolate the sample bottle from the sampling manifold.

9.8 If successive samples are to be taken, repeat 9.5 and 9.6. If not, the volume of the pipette should be adapted so that the sample taken is representative of material transferred from the main cylinder.

9.9 At the completion of sampling, close all the sample bottle valves. Any residual UF₆ in the equipment and sampling lines is either blown back using dry gas or is evacuated into a UF₆ trap. Close the sampling valve and evacuate and backfill the equipment with dry gas.

9.10 Remove, identify, cap, and weigh the sample bottles. Local safety regulations may demand that the UF₆ is allowed to cool and solidify (below atmospheric pressure) before this operation is carried out.

10. Keywords

10.1 bulk sampling; nuclear material; uranium hexafluoride

ASTM International takes no position respecting the validity of any patent rights asserted in connection with any item mentioned in this standard. Users of this standard are expressly advised that determination of the validity of any such patent rights, and the risk of infringement of such rights, are entirely their own responsibility.

This standard is subject to revision at any time by the responsible technical committee and must be reviewed every five years and if not revised, either reapproved or withdrawn. Your comments are invited either for revision of this standard or for additional standards and should be addressed to ASTM International Headquarters. Your comments will receive careful consideration at a meeting of the responsible technical committee, which you may attend. If you feel that your comments have not received a fair hearing you should make your views known to the ASTM Committee on Standards, at the address shown below.

This standard is copyrighted by ASTM International, 100 Barr Harbor Drive, PO Box C700, West Conshohocken, PA 19428-2959, United States. Individual reprints (single or multiple copies) of this standard may be obtained by contacting ASTM at the above address or at 610-832-9585 (phone), 610-832-9555 (fax), or service@astm.org (e-mail); or through the ASTM website (www.astm.org).