



# Standard Specification for Borosilicate Glass Pipe and Fittings for Drain, Waste, and Vent (DWV) Applications<sup>1</sup>

This standard is issued under the fixed designation C 1053; the number immediately following the designation indicates the year of original adoption or, in the case of revision, the year of last revision. A number in parentheses indicates the year of last reapproval. A superscript epsilon ( $\epsilon$ ) indicates an editorial change since the last revision or reapproval.

*This standard has been approved for use by agencies of the Department of Defense.*

## 1. Scope

1.1 This specification covers chemically resistant, low expansion, Type I, borosilicate glass, Class A (see Specification E 438), used to manufacture corrosion-resistant pipe and fittings for drain, waste, and vent service.

1.2 The pipe and fittings covered by the specification are intended for chemical resistant service above and below grade under gravity flow or vacuum conditions.

1.3 The pipe and fittings shall have beaded or plain ends.

## 2. Referenced Documents

2.1 *ASTM Standards:*<sup>2</sup>

C 600 Method of Thermal Shock Test on Glass Pipe

C 623 Test Method for Young's Modulus, Shear Modulus, and Poisson's Ratio for Glass and Glass-Ceramics by Resonance

C 693 Test Method for Density of Glass by Buoyancy

E 438 Specification for Glasses in Laboratory Apparatus

## 3. Ordering Information

3.1 The minimum ordering information for material under this specification shall include the following information:

3.1.1 ASTM designation and date of issue,

3.1.2 Manufacturer's catalog number or parts identification,

3.1.3 Quantity ordered,

3.1.4 Special test or certification requirements,

3.1.5 Special packaging or marking, if required, and

3.1.6 Accessory items such as couplings, drains, adapters, and cutters.

## 4. Materials and Manufacture

4.1 The glass components shall represent good workmanship as consistent with standard glass process capabilities.

## 5. Chemical Requirements

5.1 The chemical requirements shall be as described in Specification E 438.

## 6. Physical Requirements

6.1 The physical requirements shall be as described in Specification E 438.

6.2 Refer also to Annex A1 for additional physical requirements.

## 7. Operating Temperatures

7.1 *Minimum Operating Temperature*—The minimum rated operating temperature for all sizes shall be  $-40^{\circ}\text{F}$  ( $-40^{\circ}\text{C}$ ) provided the material being conveyed is fluid.

7.2 *Maximum Operating Temperature*—The maximum rated continuous operating temperature shall be  $212^{\circ}\text{F}$  ( $100^{\circ}\text{C}$ ).

7.3 *Thermal Shock Resistance*—The maximum allowable temperature differential for installed systems shall be in accordance with Table 1 for the various pipe sizes. Maximum temperature differential refers to an almost instantaneous temperature change, such as low-pressure steam followed directly by a flush of ice cold water, or the reverse. Maximum temperature differential pertains to either inside or outside pipe surfaces.

7.3.1 Thermal shock resistance is not ordinarily tested. If thermal shock resistance may be questioned, it shall be tested in accordance with Method C 600. If all pieces tested pass the allowable temperature differential, the lot shall be accepted. If one or more failures occur, a retest shall be made using a sample size twice that of the first test. If any failures occur on the retest, the entire shipment shall be retested.

## 8. Pressure Rating

8.1 DWV piping systems are designed for gravity flow only.

8.2 All pipe sizes are suitable for vacuum service.

## 9. Dimensions and Permissible Variations

9.1 *Beaded Flanges:*

9.1.1 *Flange Face Flatness*—Maximum permissible deviation from a flat plane across the face of a flange on all sizes shall be  $\frac{1}{16}$  in. (1.6 mm).

<sup>1</sup> This specification is under the jurisdiction of ASTM Committee C14 on Glass and Glass

Products and is the direct responsibility of Subcommittee C14.05 on Glass Pipe.

Current edition approved Sept. 1th, 2005. Published October 2005. Originally approved in 1985. Last previous edition approved in 2000 as C 1053 – 00.

<sup>2</sup> For referenced ASTM standards, visit the ASTM website, www.astm.org, or contact ASTM Customer Service at service@astm.org. For *Annual Book of ASTM Standards* volume information, refer to the standard's Document Summary page on the ASTM website.

**TABLE 1 Maximum Temperature Differential for Thermal Shock**

Pipe Size, in. (mm)	Sudden Temperature Difference, Max °F (°C)
1½–3 (38–76)	200 (93)
4 (102)	175 (78)
6 (152)	160 (71)

9.1.2 *Flange Face Squareness*—Flange faces of both pipe and fittings shall be square to the pipe centerline within the limits prescribed in **Table 2**.

9.1.2.1 Squareness of straight pipe lengths shall be measured by placing the pipe on rollers, located approximately 2 in. (51 mm) from each end, and butting one end against a flat plate perpendicular to the axis of the rollers. The pipe shall be rotated and length variation read with a suitable mechanism, such as a dial indicator. The maximum reading shall not exceed that shown in **Table 2** for the respective pipe size.

9.1.2.2 Pipe fittings shall be measured for flange squareness by a gage having flat plates constructed at the angle required by that fitting. One flange shall be firmly placed on one plate, and any difference between the remaining flange face and the other surface plate shall be measured with Feller gages. Differences shall not exceed the amount shown in **Table 2** for the respective fitting size.

9.1.3 *Flange Dimensions and Specifications*—Beaded flange dimensions shall be as required by the manufacturer for the system.

9.2 *Bow:*

9.2.1 *Bow for All Pipe Diameters*—Bow shall be measured by supporting the pipe in “V” blocks approximately 2 in. from each end with a dial gage at midlength, rotating the pipe full 360°. The total dial deflection divided by two is the measure of bow, which shall not exceed 0.25 % of the pipe length.

9.3 *Dimensions of All Pipe and Fittings:*

9.3.1 Dimensional specifications for pipe and common fittings shall be as shown in the manufacturer’s literature. Typical configurations are as illustrated in **Figs. 1-45**.

**10. Inspection**

10.1 Inspection of the material shall be made at the point of delivery unless otherwise agreed upon by the purchaser and the seller.

**11. Packaging**

11.1 Pipe, fittings, and hardware shall be so packaged as to prevent damage during transportation and handling. Those

**TABLE 2 Flange Face Squareness**

Nominal Pipe Size, in.	Squareness Measurement, Max, in.
1½ to 2	1/32
3	3/64
4	1/16
6	5/64

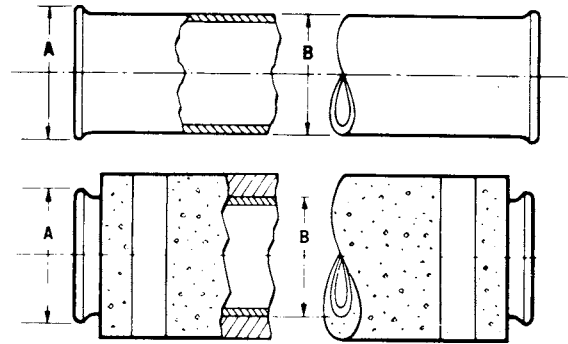

Size, in.	A (OD)		Wall Thick-ness, in.	Length, ft <sup>A</sup>
	Diameter, in.	Diameter, in.		
1½	2.06	1.84	0.17	5 and 10
2	2.58	2.34	0.17	5 and 10
3	3.69	3.41	0.20	5 and 10
4	4.84	4.53	0.27	5 and 10
6	7.12	6.66	0.33	5 and 10

<sup>A</sup>Length includes coupling allowance.

Nominal OD Over EPS<sup>A</sup>

1½ in.	2 13/16
2 in.	3 5/16
3 in.	5
4 in.	6 1/4
6 in.	8 9/16

<sup>A</sup>Pipe with EPS (expanded polystyrene) covering for underground service; lengths of 5 ft only.

**FIG. 1 Standard Specifications for Straight Lengths of Pipe**

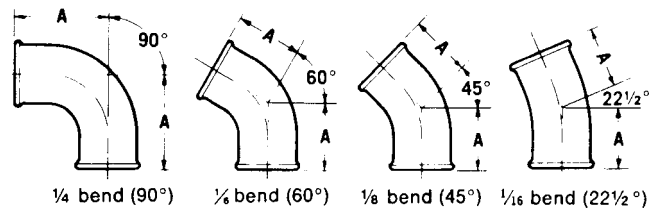

Size	A Dimension <sup>A</sup> , in.			
	90°	60°	45°	22 1/2 °
1½	3	2 1/2	2	—
2	3 1/4	2 3/4	2 1/4	2 1/4
3	5	3 1/2	2 3/4	2 3/4
4	7	4 1/2	3 1/4	3 1/4
6	—	—	7	—

<sup>A</sup>Dimensions to beaded flanges include coupling allowance.

**FIG. 2 Elbows**

items packed in containers conforming to all construction requirements of consolidated freight classification as to bursting tests, size limit, and gross mass shall be considered as being properly packed.

11.2 All hardware items shall be packed in such a way as to prevent contact with glass components. Some typical hardware items are shown in **Appendix X1**.

**12. Keywords**

12.1 borosilicate; components; fittings; glass; pipe

**LONG 90°**

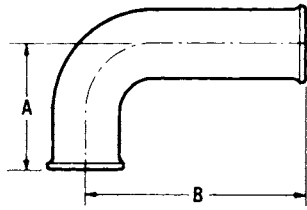

Size	A	B
1½-90°	3¾	6
2-90°	3¾	7½

**FIG. 3 Elbow**

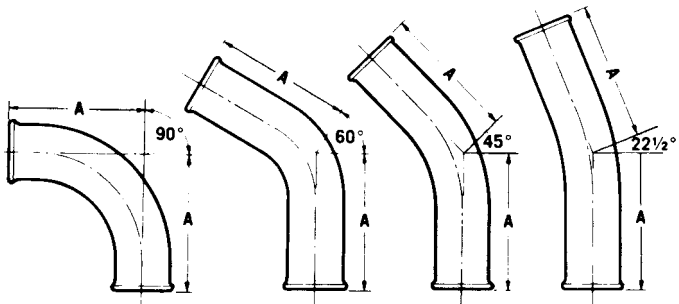

¼ bend (90°)    ¼ bend (60°)    ⅓ bend (45°)    ⅓ bend (22½°)  
A Dimensions<sup>A</sup>, in.

Size	90°	60°	45°	22½°
1½	4½	4½	4½	4½
2	5	5	5	5
3	6½	6½	6½	6½
4	9	9	9	9
6	12	12	12	12

<sup>A</sup>Dimensions to beaded flanges include coupling allowance.

**FIG. 4 Sweep Elbows**

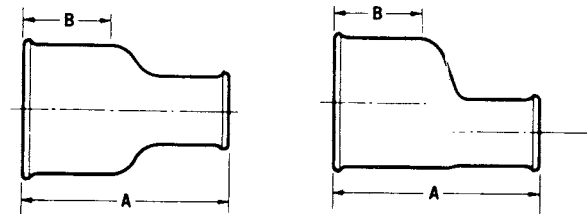

Dimensions<sup>A</sup>, in.

Size	A	B (min)
2 by 1½	4	1¾
3 by 1½	5	2¼
3 by 2	5	2¼
4 by 1½	7	3
4 by 2	7	3
4 by 3	7	3
6 by 1½	9	4
6 by 2	9	4
6 by 3	9	4
6 by 4	9	4

<sup>A</sup>Dimensions to beaded flanges include coupling allowance.

**FIG. 6 Straight Reducers and Eccentric Reducers**

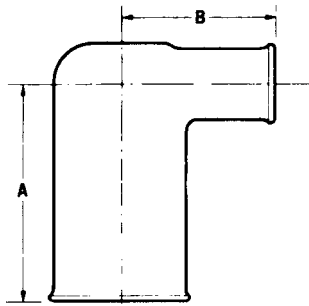

Dimensions<sup>A</sup>, in.

Size	A	B
2 by 1½	4	3½
3 by 1½	5	4
3 by 2	5	4½
4 by 1½	7	4½
4 by 2	7	5
4 by 3	7	5½
6 by 1½	9	5½
6 by 2	9	6
6 by 3	9	6½
6 by 4	9	8

<sup>A</sup>Dimensions to beaded flanges include coupling allowance.

**FIG. 5 Quarter Bend Reducer**

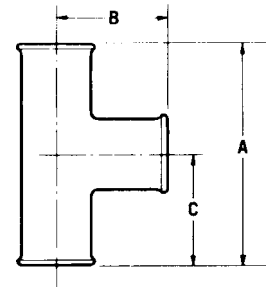

Dimensions<sup>A</sup>, in.

Size	A	B	C
1½ by 1½	6	3	3
2 by 1½	8	3¼	4
2 by 2	8	4	4
3 by 1½	12	4½	6
3 by 2	12	4½	6
3 by 3	12	6	6
4 by 1½	14	5	7
4 by 2	14	5	7
4 by 3	14	6½	7
4 by 4	14	8	7
6 by 3	20	7¾	10
6 by 4	20	9	10
6 by 6	20	10	10

<sup>A</sup>Dimensions to beaded flanges include coupling allowance.

**FIG. 7 Straight T**

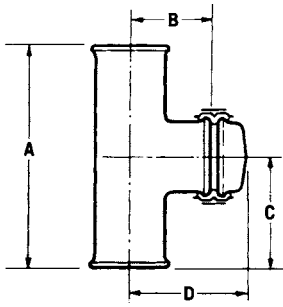

Size	A	B	C	D
1½ x 1½	6	2 <sup>3</sup> / <sub>16</sub>	3	3 <sup>1</sup> / <sub>16</sub>
2 x 2	8	2 <sup>11</sup> / <sub>16</sub>	4	3 <sup>11</sup> / <sub>16</sub>
3 x 3	12	3 <sup>9</sup> / <sub>16</sub>	6	4 <sup>11</sup> / <sub>16</sub>
4 x 4	14	4 <sup>5</sup> / <sub>8</sub>	7	5 <sup>7</sup> / <sub>8</sub>

Test Tee and cleanout comes as complete assembly including cap and coupling.

FIG. 8 Test T with Clean-Out

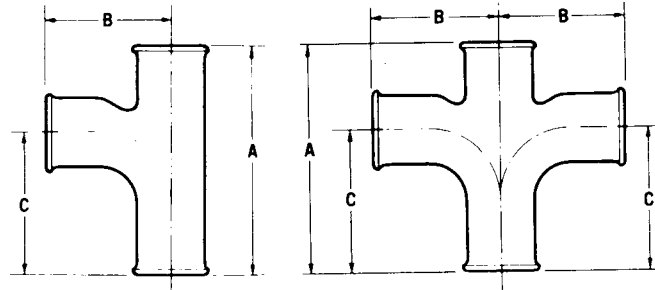

Dimensions<sup>A</sup>, in.

Size	A	B	C
1½ by 1½	6	3½	3¾
2 by 1½	8	3¾	5
2 by 2	8	4½	5
3 by 1½	12	4¼	7 <sup>7</sup> / <sub>16</sub>
3 by 2	12	5	7 <sup>7</sup> / <sub>16</sub>
3 by 3	12	6 <sup>3</sup> / <sub>8</sub>	7 <sup>7</sup> / <sub>16</sub>
4 by 1½	14	4 <sup>7</sup> / <sub>4</sub>	8¾
4 by 2	14	5 <sup>5</sup> / <sub>4</sub>	8¾
4 by 3	14	7	8¾
4 by 4	14	8¼	8¾
6 by 2	20	6¾	12 <sup>3</sup> / <sub>8</sub>
6 by 3	20	8	12 <sup>3</sup> / <sub>8</sub>
6 by 4	20	9 <sup>5</sup> / <sub>16</sub>	12 <sup>3</sup> / <sub>8</sub>
6 by 6	20	12	12 <sup>3</sup> / <sub>8</sub>

<sup>A</sup>Dimensions to beaded flanges include coupling allowance.

FIG. 9 Sanitary T

Size	A	B	C	D
1½ x 1½ x 2	6	3 <sup>7</sup> / <sub>8</sub>	2 <sup>1</sup> / <sub>8</sub>	7

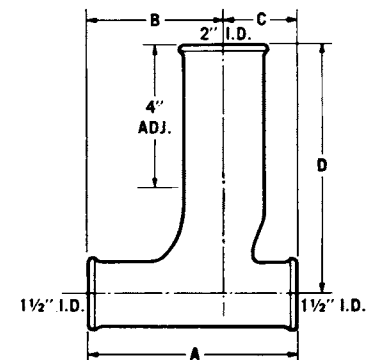

FIG. 10 Adjustable Sanitary T

Size	A	B	C
1½ x 1½ x 1½	8¾	3½	3½

\*Can be field cut.

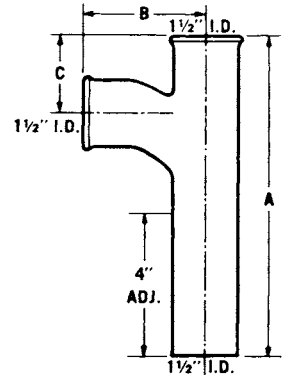

FIG. 11 Adjustable Sanitary T (Plain End Outlet)

Size	A	B	C
1½ x 1½	4½	2⅞	2¼
2 x 1½	4¾	2⅜	2⅜
2 x 2	5⅜	2¾	2¾
3 x 2	9	4⅞	5⅞
3 x 3	9	4⅞	5⅞
4 x 1½	10	4⅝	6⅝
4 x 2	10	4⅞	6⅝
4 x 3	10	5⅜	6⅝
4 x 4	10	6¼	6⅝
6 x 2	16	5⅞	9½
6 x 3	16	6¾	9½
6 x 4	16	7⅞	9½
6 x 6	16	9⅞	9¼

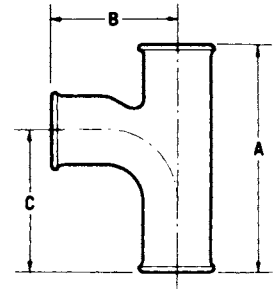
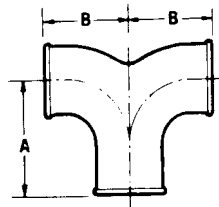

FIG. 12 Compact Single Sanitary T



Dimensions<sup>A</sup>, in.

Size	A	B
1½	3	2⅞
2 by 2 by 1½	3¼	2¼
2	3½	2¼
3	5	4½
4	6½	5¾
6	8½	7

<sup>A</sup>Dimensions to beaded flanges include coupling allowance.

FIG. 13 Double Quarter Bend

Size	A	B
1½	10	2½
**2 x 2 x 1½	10	2¼
2	10	2¼
3		
4		
6		

\*Can be field cut.  
 \*\*Branch is 1½" I.D.

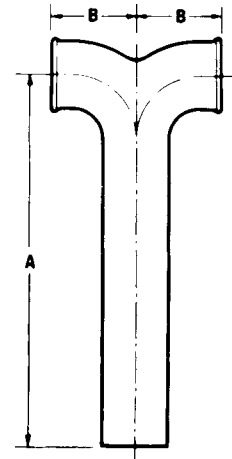
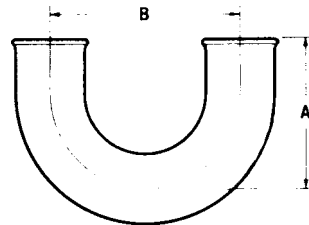

FIG. 14 Double Quarter Bend (Plain End Outlet)



Dimensions<sup>A</sup>, in.

Size	A	B
1½	4	5
2	4½	5½
3	5½	6½
4	6½	7½

<sup>A</sup>Dimensions to beaded flanges include coupling allowance.

FIG. 15 U Bend



Dimensions<sup>A</sup>, in.

Size	A
1½	1
2	1
3	1½
4	1¼
6	1½

<sup>A</sup>Dimensions to beaded flanges include coupling allowance.

FIG. 16 Cleanout Plug

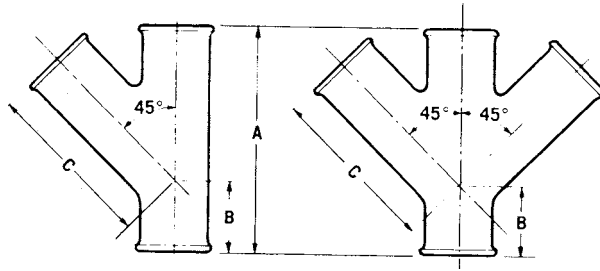

Dimensions<sup>A</sup>, in.

Size	A	B	C
1½ by 1½	6	1⅞	4½
2 by 1½	8	2½	4¾
2 by 2	8	2½	6
3 by 1½	12	3¾	5½
3 by 2	12	3¾	6¾
3 by 3	12	3¾	8
4 by 1½	14	4½	6⅝
4 by 2	14	4½	7½
4 by 3	14	4½	8¾
4 by 4	14	4½	10
6 by 2	20	5¾	9
6 by 3	20	5¾	10⅝
6 by 4	20	5¾	11½
6 by 6	20	5¾	14

<sup>A</sup>Dimensions to beaded flanges include coupling allowance.

FIG. 17 Drainline Y

Size	A	B	C
1½ x 1½	5⅝	1⅞	4
2 x 2	5⅞	1¼	4⅝
3 x 2	9	2 <sup>9</sup> / <sub>16</sub>	6 <sup>5</sup> / <sub>16</sub>
3 x 3	9	2 <sup>9</sup> / <sub>16</sub>	7 <sup>1</sup> / <sub>16</sub>
4 x 1½	10	3⅞	6¼
4 x 2	10	2 <sup>7</sup> / <sub>8</sub>	7¾
4 x 3	10	2	8⅞
4 x 4	10	2	8⅝
6 x 2	16	4 <sup>7</sup> / <sub>8</sub>	9 <sup>7</sup> / <sub>8</sub>
6 x 3	16	5⅞	10 <sup>3</sup> / <sub>8</sub>
6 x 4	16	4½	11⅝
6 x 6	16	4⅝	12⅝

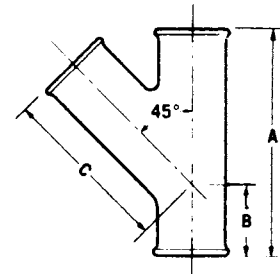
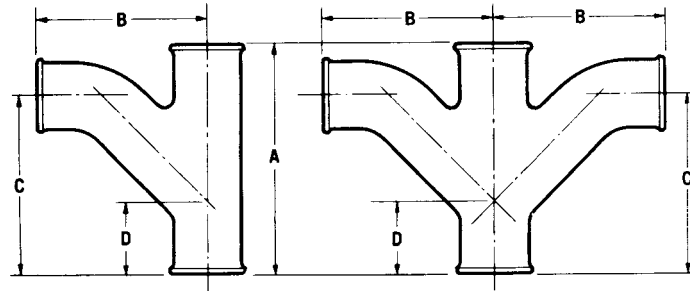

FIG. 18 Compact Single Drainline Y



Dimensions<sup>A</sup>, in.

Size	A	B	C	D
1½ by 1½	6	4½	4⅝	1⅞
2 by 1½	8	4¾	5½	2½
2 by 2	8	6	6¼	2½
3 by 1½	12	5⅞	7¼	3¾
3 by 2	12	6½	8	3¾
3 by 3	12	8½	9	3¾
4 by 1½	14	6	8½	4½
4 by 2	14	7	9¼	4½
4 by 3	14	9	10¼	4½
4 by 4	14	11	11	4½
6 by 2	20	8¼	11⅝	5¾
6 by 3	20	10	12½	5¾
6 by 4	20	12	13½	5¾
6 by 6	20	15	14½	5¾

<sup>A</sup>Dimensions to beaded flanges include coupling allowance.

FIG. 19 Combination Y and 1/8 Bend

Size	A	B	C	D
2 x 1½	5⅞	3¾	3¾	1⅝
2 x 2	6	4⅞	4⅝	1½
3 x 2	9	6⅛	6⅜	2¾
3 x 3	9	6⅛	6⅜	2¼
4 x 1½	10	5⅜	6⅜	2⅞
4 x 2	10	5⅜	6⅜	2⅞
4 x 3	10	6⅝	7⅝	3⅞
4 x 4	10	6⅞	7⅜	2⅛
6 x 2	16	7⅝	9⅝	4⅝
6 x 3	16	8⅞	9⅝	4¾
6 x 4	16	9⅞	10⅜	4⅝
6 x 6	16	11¼	10⅞	3½

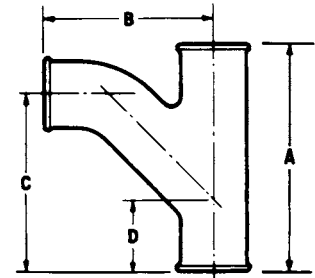

FIG. 20 Compact Combination Y and 1/8 Bend

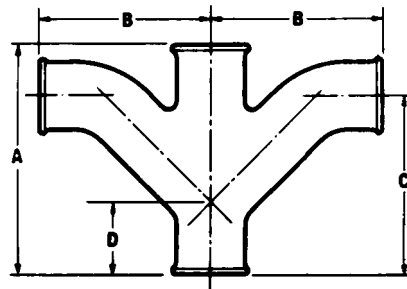
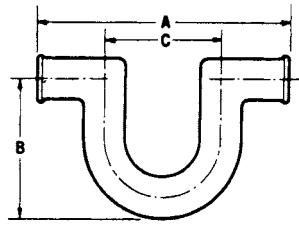

FIG. 21 Compact Double Combination Y and 1/8 Bend





Dimensions<sup>A</sup>, in.

Size Inlet by Outlet	A	B	C	D	E
1½ by 1½	11	6	5	3	3
2 by 2	12	6 <sup>11/16</sup>	5½	3¼	3½
3 by 3	14½	8¼	6½	4	4
4 by 4	17½	9¾	7½	5	5
6 by 6	38	14 <sup>7/8</sup>	24	7	7

<sup>A</sup> Dimensions to beaded flanges include coupling allowance.

FIG. 22 Running Trap

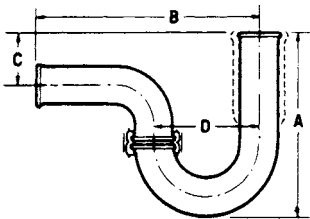

NOTE—Swivel traps include standard 1½ in. coupling.

Dimensions<sup>A</sup>, in.

Size Inlet by Outlet	A	B	C	D
1½ by 1½	9 <sup>11/16</sup>	11	1 <sup>5/8</sup>	5
2 by 1½	8¾	11	1 <sup>5/8</sup>	5
2 by 2	8¾	13	1¼	5½

<sup>A</sup> Dimensions to beaded flanges include coupling allowance.

FIG. 23 Swivel Trap—P Style, Long Outlet

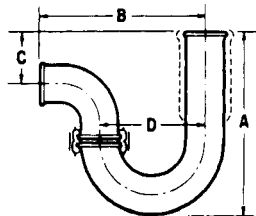

Dimensions, in.

Size Inlet by Outlet	A	B	C	D
1½ by 1½	8¾	8	2	5
2 by 1½	8¾	8	2	5
2 by 2	9 <sup>11/16</sup>	8¾	1 <sup>5/8</sup>	5½

FIG. 24 Swivel Trap—P Style, Short Outlet

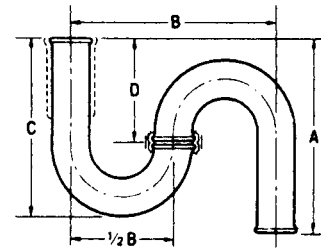

NOTE—Swivel traps include standard 1½ in. coupling.

Dimensions<sup>A</sup>, in.

Size Inlet by Outlet	A	B	C	D
1½ by 1½	10	10	8¾	5
2 by 1½	10	10	8¾	5
2 by 2	9¾	11	9 <sup>11/16</sup>	4 <sup>7/8</sup>

<sup>A</sup> Dimensions to beaded flanges include coupling allowance.

FIG. 25 Swivel Trap—S Style

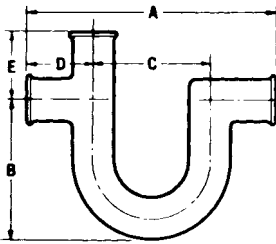

FIG. 26 Running Trap (Vented)

Size Inlet x Outlet	A	B	C	D
1½ x 1½	8¾	17	1½	5
2 x 1½	8¾	17	1½	5
2 x 2	9 <sup>11</sup> / <sub>16</sub>	17½	1¼	5½

\*Plain end outlet, can be field cut.

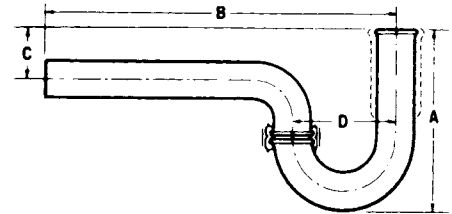
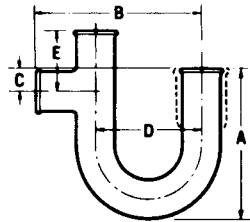

FIG. 27 Swivel Trap—P Style (Plain End Outlet)



Size Inlet x Outlet	Vent Size	A	B	C	D	E
1½ x 1½	1½	7	8	1	5	3
*2 x 1½	1½	7½	8	1½	5	3
2 x 2	2	8 <sup>3</sup> / <sub>16</sub>	8¾	1½	5½	3½
3 x 3	3	10¼	10½	2	6½	4
4 x 4	4	12¼	12½	2½	7½	5
6 x 6	4	16¾	31	2½	24	7

\*Has expanded inlet.

FIG. 28 Trap—P Style (Vented)

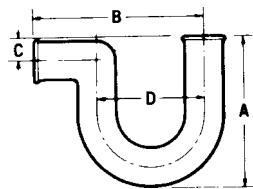

Dimensions, in.

Size Inlet by Outlet	A	B	C	D
1½ by 1½	7	8	1	5
2 by 1½	7½	8	1½	5
2 by 2	8 <sup>3</sup> / <sub>16</sub>	8¾	1½	5½
3 by 3	10¼	10½	2	6½
4 by 4	12¼	12½	2½	7½
6 by 6	18½	31	3¾	24

FIG. 29 Trap—P Style

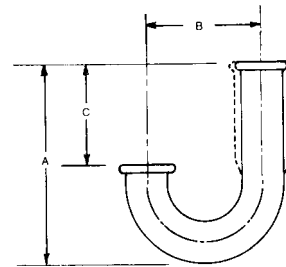

NOTE 1—J Bend can be used in combination with quarter bend and return bend to make a variety of custom swivel traps.

Size	Dimensions, in.		
	A	B	C
1½ by 1½	7 <sup>9</sup> / <sub>16</sub>	5	3½
2 by 1½	8 <sup>1</sup> / <sub>16</sub>	5	4½
2 by 2	8 <sup>7</sup> / <sub>8</sub>	5½	4½

FIG. 30 J Bend

Size Inlet x Outlet	A	B	C	D	Body I.D.
1½ x 1½	11¼	9½	10¼	4¾	3
2 x 1½	11¼	9½	10¼	4¾	3
2 x 2	11¼	11	11	5½	4

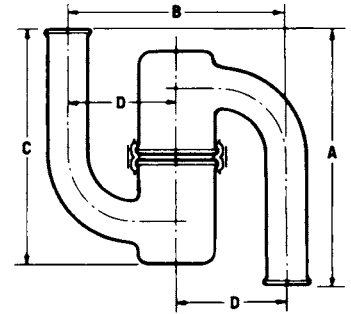
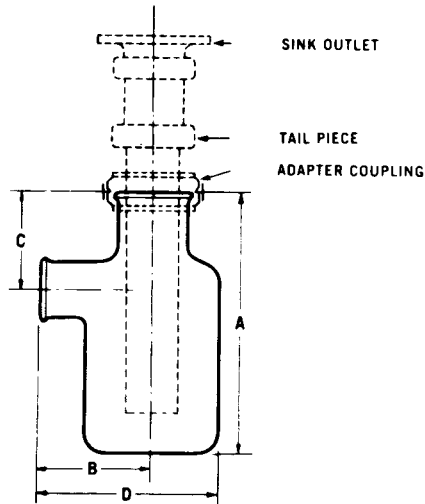
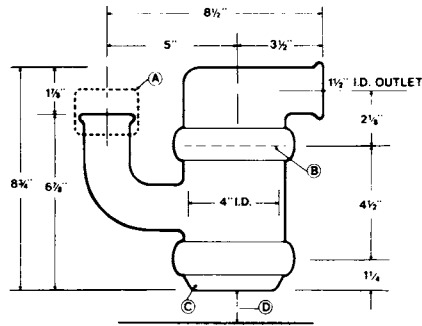

FIG. 31 Swivel Drum Trap—S Style



Size Inlet x Outlet	A	B	C	D
2 x 1½	8½	3¾	3¼	6
2 x 2	8½	3¾	4¼	6

FIG. 32 Partition Trap



Size	Description
1 1/2" x 1 1/2"	Interceptor Trap
1 1/4" O.D. Inlet	Adapter Coupling
1 1/2" O.D. Inlet	Adapter Coupling

A. Adapter Coupling

B. Perforated S.S. Screen 1/16" dia. holes 6 sq. in. free area opening.

C. Removable coupling/end cap for cleanout.

D. Min. 3" clearance required under trap for removal of end cap.

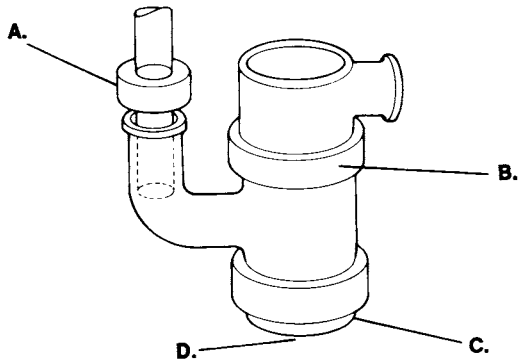

FIG. 33 Interceptor Trap

Traps available with B type cleanout.

Size Inlet x Outlet	A	B	C	D	Body I.D.
1 1/2 x 1 1/2	9	8	1	4 3/4	3
2 x 1 1/2	9	8	1 1/2	4 3/4	3
2 x 2	9 3/4	9 1/4	2	5 1/2	4

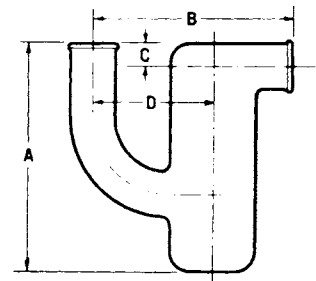
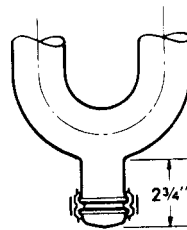

FIG. 34 Drum Trap



NOTE 1— Standard DWV trap cleanout consists of a standard glass cap of 1 1/2 in. (see Fig. 8) and a standard coupling of 1 1/2 in.

NOTE 2—No cleanouts are available on 6 in. traps

FIG. 35 Standard Cleanout

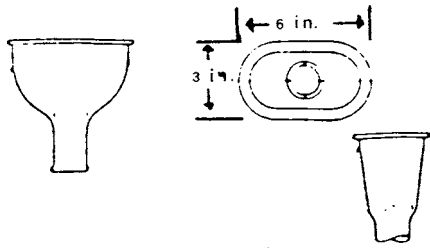

(a) 3 by 6 in. oval

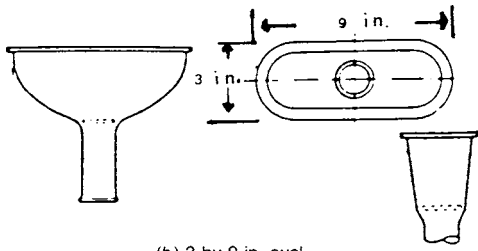

(b) 3 by 9 in. oval

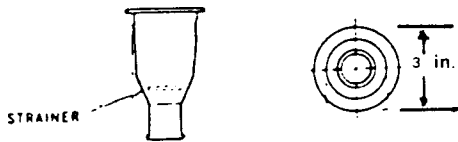

(a) 3 in. hemispherical

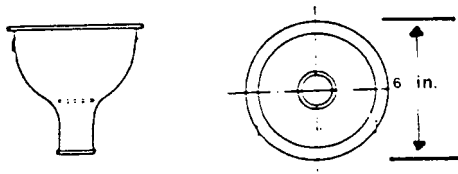

(a) 6 in. hemispherical

FIG. 36 Cup Sinks

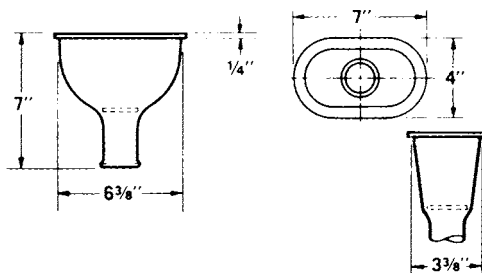

FIG. 37 Beaded Outlet 3- by 6-in. Oval

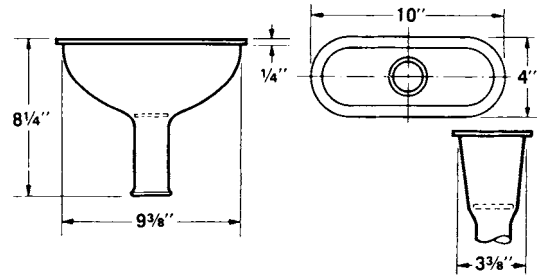

FIG. 38 Beaded Outlet 3- by 9-in. Oval

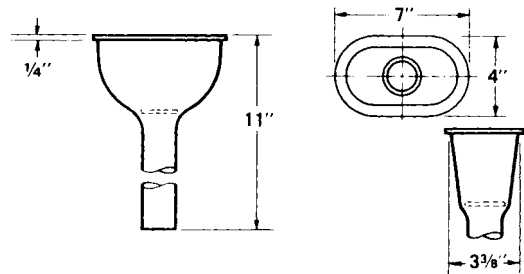

FIG. 39 Plain End Outlet 3- by 6-in. Oval

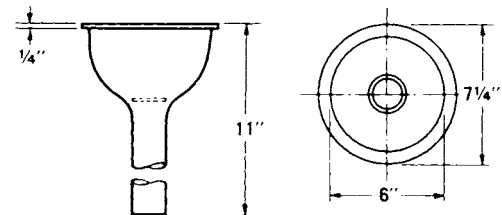

FIG. 40 Plain End Outlet 6-in. Hemispherical

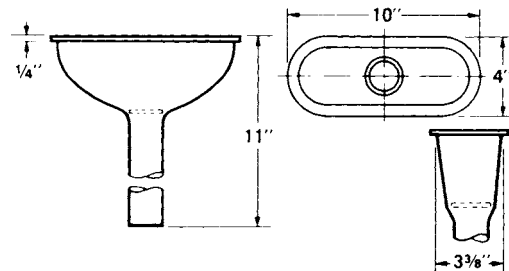

FIG. 41 Plain End Outlet 3- by 9-in. Oval

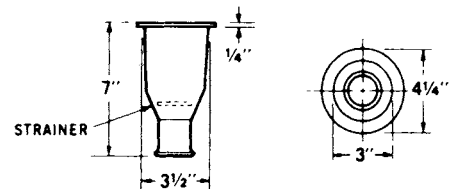

FIG. 42 Beaded Outlet 3-in. Hemispherical

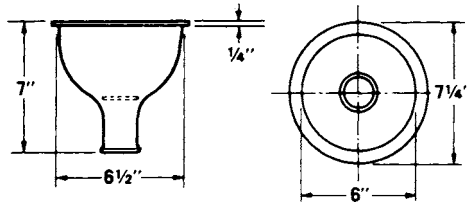

FIG. 43 Bead Outlet 6-in. Hemispherical

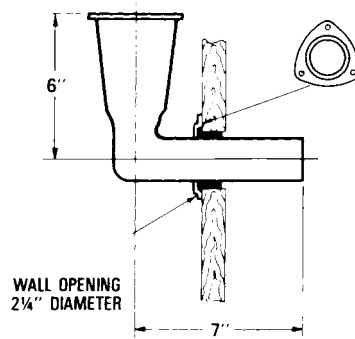

FIG. 44 3- by 6-in. Oval Horizontal Wall-Mounted Cup Sink 1 1/2-in. Plain End Outlet

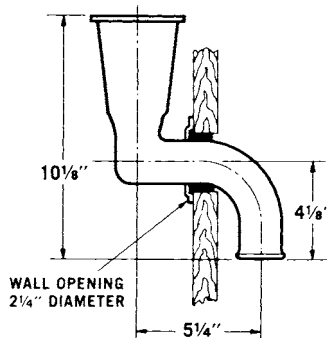

FIG. 45 3- by 6-in. Oval Vertical 1 1/2-in. Outlet Wall-Mounted Cup Sink

## ANNEX

### (Mandatory Information)

#### A1. GENERAL REFERENCE DATA FOR LOW-EXPANSION BOROSILICATE GLASS

A1.1 *Density*—2.24 g/cm<sup>3</sup>, measured at room temperature by Test Method C 693.

A1.2 *Thermal Conductivity*—0.73 Btu·ft/h·ft<sup>2</sup>·°F (0.0035 cal·cm/s·cm<sup>2</sup>·°C), measured at room temperature.

A1.3 *Specific Heat*—0.20 Btu/lb·°F (0.20 cal/g·°C), measured at 75°C.

A1.4 *Young's Modulus*—9 000 000 to 10 000 000 psi (62 to 69 GPa) when measured at room temperature in accordance with Test Method C 623.

A1.5 *Tensile Strength*—Because of effect of surface conditions on ultimate strength, nominal design shall be 1000 psi (6.9 MPa).

APPENDIX

(Nonmandatory Information)

X1. TYPICAL HARDWARE

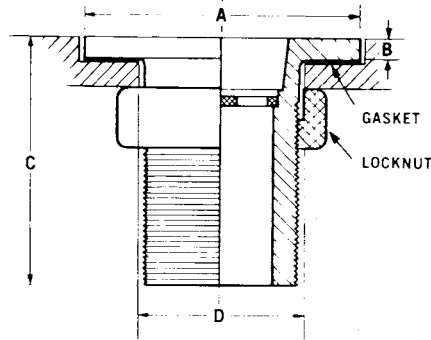

NOTE 1—Assembly consists of the following sink strainer fluorocarbon plastic 1½-in. or 2-in. sink outlet fluorocarbon plastic; rubber gasket; and locknut.

Size	Dimensions, in.			
	A	B	C	D
1½	3¾	¼	2¾	2
2	3 <sup>15</sup> / <sub>16</sub>	¼	3	2 <sup>5</sup> / <sub>8</sub>
2	3¾	¼	3	2 <sup>5</sup> / <sub>8</sub>

FIG. X1.1 Sink Outlet Assembly

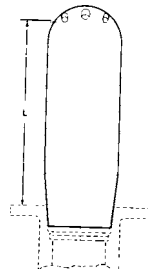

NOTE 1—Sink overflow is made of fluorocarbon plastic. Beehive type can be modified to open type by cutting off top beehive section.

Dimensions, in.	
Sink Outlet Size	Size
1½	1½ by 4
1½	1½ by 6
1½	1½ by 8

FIG. X1.2 Sink Overflow

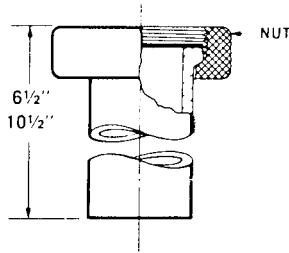

NOTE 1—Tailpiece is available in 6½- and 10½-in. lengths. Specify length when ordering. Glass can be field cut to exact length. Assembly consists of a plastic nut and a tailpiece.

NOTE 2—This assembly can be used on other 1½-in. plastic or metal sink outlets having straight pipe threads.

FIG. X1.3 1½-in. Tailpiece Assembly

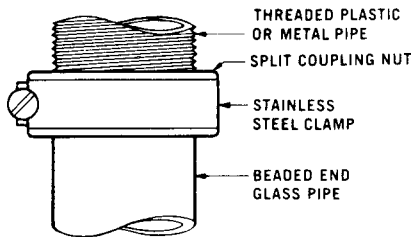

NOTE 1—Split coupling of 1½ in. is used to join 1½-in. beaded glass pipe to threaded 1½-in. I.P.S. pipe.

NOTE 2—The assembly consists of a split coupling nut and a stainless steel clamp.

FIG. X1.4 1½-in. Split Coupling (Threaded to Beaded Pipe)

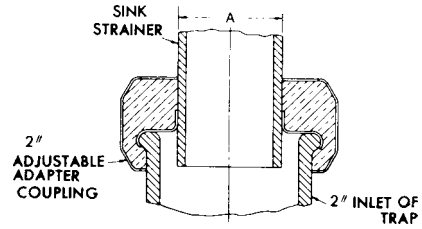

Dimensions, in.

Size	O.D. Range A
2 by 1¾	1.70–1.78
2 by 1½	1.48–1.53
2 by 1⅞	1.82–1.90

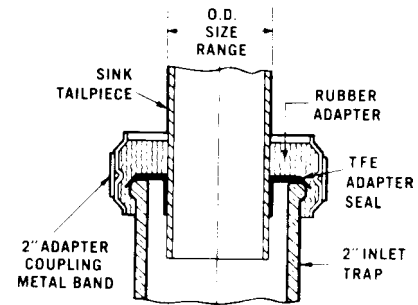

NOTE 1—Adapter assembly is used to join glass DWV pipe or fittings, or both, to plain end sink tailpieces. The assembly consists of a stainless steel outer band with bolt and rubber adapter with TFE adapter seal.

Dimensions, in.

Size	Tailpiece Style	O.D. Size Range
2 by 1½	Glass tail pipe extension, metal tubing, and lead tailpiece extensions	1.48 to 1.53
2 by 1¾	Lead, glass, and cup sink	1.70 to 1.78
2 by 1⅞	1½ DWV glass pipe and fittings	1.82 to 1.90

FIG. X1.5 Adapter Coupling



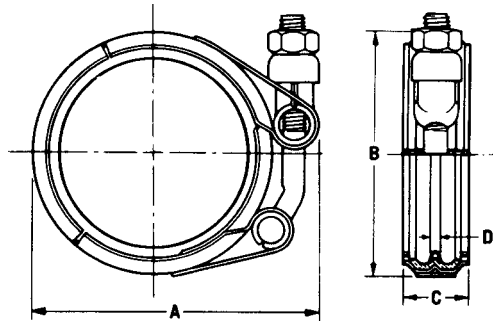

NOTE 1—Coupling is used for joining all sizes of glass DWV pipe and fittings. The assembly consists of stainless steel outer band with bolt and rubber compression liner with TFE seal ring.

Dimensions, in.				
Size	A	B	C	D
1½	3	2⅝	1⅝	⅜
2	3½	3⅞	1⅝	⅜
3	4¾	4¼	1⅞	⅜
4	6	5½	1½	⅜
6	8¼	7¾	1⅞	¼

FIG. X1.6 Coupling (Bead to Bead)

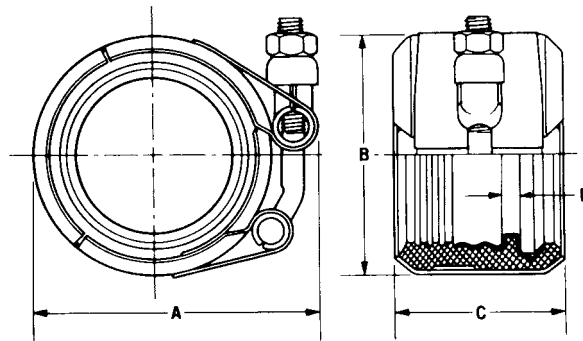

NOTE 1—Coupling is used for joining all sizes of beaded glass to plain end (cut) glass pipe, lead, IPS metal, or plastic pipe. The assembly consists of a stainless steel band and rubber compression liner with TFE seal ring.

Dimensions, in.				
Size	A	B	C	D
1½	3	2¾	1¾	⅜
2	3⅝	3¼	1¾	⅜
3	4⅞	4¼	2⅞	⅜
4	6	5⅞	2⅞	⅜
6	8⅝	7⅞	4	¼

FIG. X1.7 B/P Coupling (Bead to Plain End)

*ASTM International takes no position respecting the validity of any patent rights asserted in connection with any item mentioned in this standard. Users of this standard are expressly advised that determination of the validity of any such patent rights, and the risk of infringement of such rights, are entirely their own responsibility.*

*This standard is subject to revision at any time by the responsible technical committee and must be reviewed every five years and if not revised, either reapproved or withdrawn. Your comments are invited either for revision of this standard or for additional standards and should be addressed to ASTM International Headquarters. Your comments will receive careful consideration at a meeting of the responsible technical committee, which you may attend. If you feel that your comments have not received a fair hearing you should make your views known to the ASTM Committee on Standards, at the address shown below.*

*This standard is copyrighted by ASTM International, 100 Barr Harbor Drive, PO Box C700, West Conshohocken, PA 19428-2959, United States. Individual reprints (single or multiple copies) of this standard may be obtained by contacting ASTM at the above address or at 610-832-9585 (phone), 610-832-9555 (fax), or [service@astm.org](mailto:service@astm.org) (e-mail); or through the ASTM website ([www.astm.org](http://www.astm.org)).*