



Standard Test Method for Measurement of Masonry Flexural Bond Strength¹

This standard is issued under the fixed designation C 1072; the number immediately following the designation indicates the year of original adoption or, in the case of revision, the year of last revision. A number in parentheses indicates the year of last reapproval. A superscript epsilon (ϵ) indicates an editorial change since the last revision or reapproval.

This standard has been approved for use by agencies of the Department of Defense.

1. Scope*

1.1 This test method covers the determination of flexural bond strength of nonreinforced masonry by physical testing of each joint of masonry prisms.

1.2 *This standard does not purport to address all of the safety concerns, if any, associated with its use. It is the responsibility of the user of this standard to establish appropriate safety and health practices and determine the applicability of regulatory limitations prior to use.*

2. Referenced Documents

2.1 *ASTM Standards:*²

C 67 Test Methods of Sampling and Testing Brick and Structural Clay Tile

C 140 Test Methods of Sampling and Testing Concrete Masonry Units

C 270 Specification for Mortar for Unit Masonry

C 780 Test Method for Preconstruction and Construction Evaluation of Mortars for Plain and Reinforced Unit Masonry

C 1357 Test Methods for Evaluating Masonry Bond Strength

C 1532 Practice for Selection, Removal, and Shipment of Masonry Assemblage Specimens from Existing Construction

3. Significance and Use

3.1 This test method is intended to provide a simple and economical means for the determination of comparative values

of flexural bond strength. It may be used either on specimens especially fabricated for bond strength evaluation or on specimens cut from existing masonry.

3.2 The bond strengths determined from this test method can be used as a means of evaluating the compatibility of mortars and masonry units. It may also be used to determine the effect on flexural bond strength of such factors as masonry unit and mortar properties, workmanship, curing conditions, coatings on masonry units, or any other factors that may be of concern.

3.3 Flexural bond strength determined by this test method should not be interpreted as the flexural bond strength of a wall constructed of the same material. However, results may be used to predict the flexural strength of a wall. Nor should it be interpreted as an indication of extent of bond for purposes of water permeance evaluation.

4. Apparatus

4.1 The test apparatus is shown in **Figs. 1-4**. The upper and lower clamping mechanisms shall be constructed as shown, except that the hex head bolts are permitted to be replaced by other tightening devices of equal, or greater, strength and stiffness. The support frame shall be constructed as shown or shall be constructed using configurations and materials of equal, or greater, strength and stiffness. The testing apparatus shall be constructed to apply the load vertically downward on the upper clamping system in such a manner that the upper and lower clamp do not come in contact during the tests. The prism support system shall be able to accommodate the size of the prism to be tested.

5. Sampling and Testing

5.1 *Brick Masonry Units*—Representative brick masonry units shall be sampled and tested in accordance with Test Methods **C 67**.

NOTE 1—Brick properties for which there are methods of test in Test Methods **C 67** that may be of interest are cold-water absorption, boiling-water absorption, initial rate of absorption, and compressive strength.

¹This test method is under the jurisdiction of ASTM Committee C15 on Manufactured Masonry Units and is the direct responsibility of Subcommittee C15.04 on Research.

Current edition approved June 1, 2006. Published June 2006. Originally approved in 1993. Last previous edition approved in 2005 as C 1072-05b.

²For referenced ASTM standards, visit the ASTM website, www.astm.org, or contact ASTM Customer Service at service@astm.org. For *Annual Book of ASTM Standards* volume information, refer to the standard's Document Summary page on the ASTM website.

*A Summary of Changes section appears at the end of this standard.

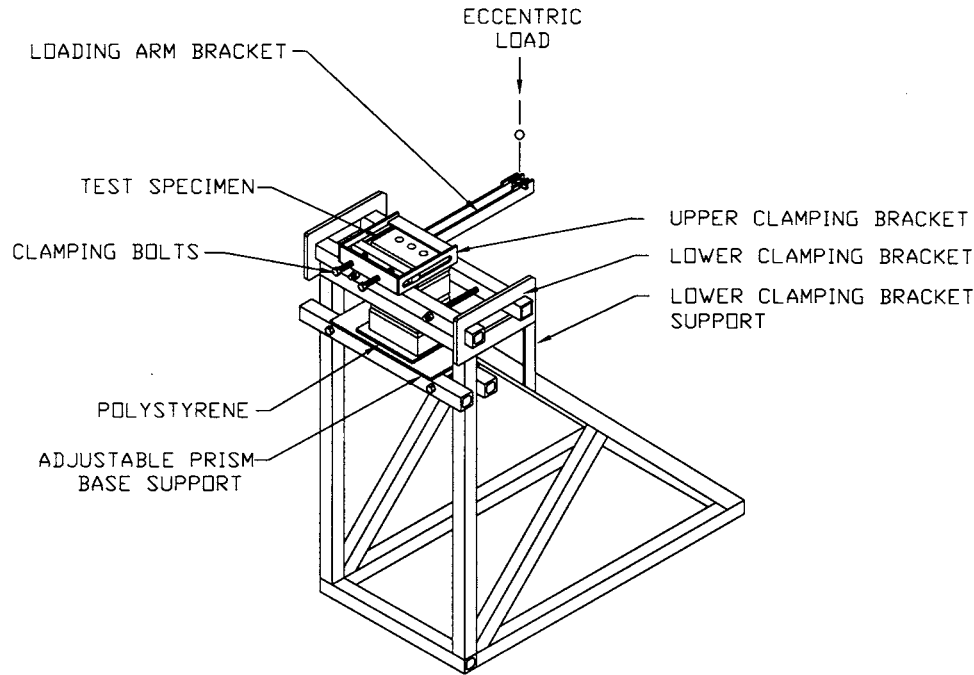

FIG. 1 Bond Wrench Testing Apparatus

5.2 *Concrete Masonry Units*—Representative concrete masonry units shall be sampled and tested in accordance with Test Methods C 140.

5.3 *Mortar*—When mortar property testing is specified, the compressive strength, air content, initial flow, cone penetration, and water retention shall be determined in accordance with the requirements of Specification C 270 or Test Method C 780.

6. Test Specimen

6.1 The test specimen shall consist of one or more prism(s). Each prism shall have not more than five joints and a minimum width (*b*) of 3.5 in. (see Note 2) as shown in Fig. X1.1.

NOTE 2—It is recommended that a width (*b*) of 1 full masonry unit be used. However, full widths may not be possible for samples obtained in accordance with 6.3.2.

6.2 Test a minimum of fifteen joints for prisms fabricated in the laboratory or field, and five joints for prisms removed from existing masonry.

6.3 Construct prisms in a laboratory or in the field or remove from existing masonry. Keep handling of the prisms to a minimum and handle in such a way that the joints will not be subjected to detrimental tensile stresses.

6.3.1 *Prisms Fabricated in Laboratory or Field:*

6.3.1.1 Set the first unit of each prism on a firm, horizontal surface without the use of mortar.

NOTE 3—An alignment device may be used to ensure plumbness and joint thickness uniformity.

6.3.1.2 Place a full or face shell mortar bed on all units without furrowing unless the effect of furrowing is being studied.

6.3.1.3 Immediately place the next course on the mortar bed and tap it to proper level and joint thickness. One face of each prism shall be in a nearly true plane.

6.3.1.4 Repeat 6.3.1.2 and 6.3.1.3 until the prisms are the desired height. Identify all specimens using a water-resistant marker.

6.3.1.5 Depending upon the desired test conditions, strike flush or tool the mortar joints. If tooling is required, tool only the joints on one face of each prism.

6.3.1.6 Unless specified otherwise, enclose all prisms in a moisture-tight bag and cure for 28 days. Record and report the daily high and low temperatures in the area where specimens are stored for curing. For prisms cured in laboratory air, maintain the laboratory air at 75 ± 15 °F (24 ± 8 °C). If other curing conditions (e.g. no moisture-tight bag) are specified, record and report all details of the curing.

NOTE 4—Workmanship during fabrication, temperature of the materials during fabrication, curing conditions, time between removal from moist curing to test, and other factors may affect the bond strengths measured by this test. Standardized specimen fabrication and curing procedures that attempt to control these variables are prescribed in Test Methods C 1357.

6.3.1.7 When prisms are made during construction at the job site, they shall be constructed in a location where they will not be disturbed, but will be subjected to atmospheric conditions similar to those in the masonry structure whose properties they are intended to represent.

6.3.2 *Prisms Obtained from Existing Masonry:*

6.3.2.1 Remove, document and transport prisms from existing masonry in accordance with Practice C 1532.

6.3.2.2 Where mortar fins and extrusions project from the specimen to the extent that they may interfere with the

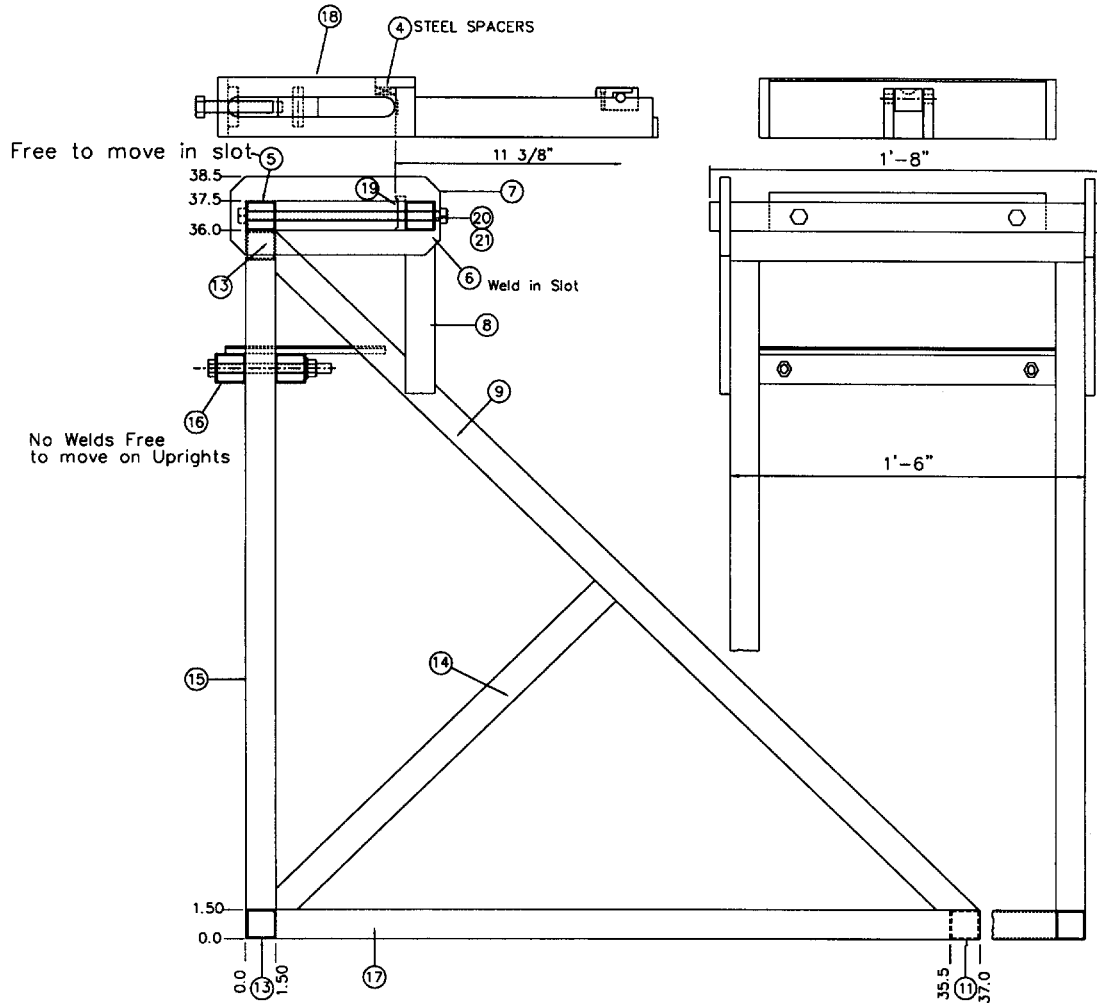

FIG. 2 Bond Wrench Frame and Elevation

attachment of the bond wrench, they shall be removed without causing damage to the specimen. Remove only enough material to enable proper attachment of the bond wrench.

7. Procedure

7.1 Place the prism vertically in the support frame as shown in Fig. 1, and clamp firmly into a locked position using the lower clamping bracket. Orient the prism so that the face of the joint intended to be subjected to flexural tension is on the same side of the specimen as the clamping screws. The prism shall be positioned at the required elevation that results in a single brick projecting above the lower clamping bracket.

7.2 Attach the upper clamping bracket to the top brick as shown in Fig. 1. Tighten each clamping bolt using a torque not greater than 50 lbf-in. (5.7 N-m).

7.3 Lower base support away from the bottom of the brick prism so that no contact occurs during testing.

7.4 Apply the load at a uniform rate so that the total load is applied in not less than 1 min or more than 3 min. Measure load (see Note 5) to an accuracy of ±2 % with maximum error of 5 lbf (22 N).

NOTE 5—The load indicated in Fig. 1 may be applied by any means, such as a testing machine, hydraulic jack, dead weights, etc. but must be within ±3° of vertical. Load may be measured using the testing machine indicator, proving ring, load cell, or any device capable of the prescribed precision. Special attention must be given to non-recording load measuring devices. Since failure of the specimen is sudden, the device must be continuously monitored or the failure load will be lost.

NOTES:

1. ALL PARTS TO BE SECURELY ARC WELDED AS SHOWN.
USE A MIN. OF 1/4" FILLET WELD ALONG LONG SIDES OF PARTS EXCEPT AS SHOWN USE E-70-XX ELECTRODES.
2. PAINT FRAME BLUE DUR-A-GRAIN STANDARD HS59BE253
3. NUMBERS IN BRACKETS INDICATE DIMENSIONS IN (MM)
4. ALL STEEL A 36 GRADE MINIMUM
5. ALL FASTENERS A307 GRADE MINIMUM
6. ALL NEOPRENE MINIMUM 70 DUROMETER HARDNESS

ITEM	PART	REQ.	SPEC.
4	STEEL SPACER	2	1" x 1" x 3/8" FLAT BAR STOCK
5	SLIDING TUBE	1	20" x 1 1/2" x 0.08 STL. SQ. TUBE
6	LOWER CLAMP BRT.	1	ASSEMBLY
7	SUPPORT	2	10 1/2"x4"x1/4" FLAT BAR STOCK
8	BRACE	2	5 1/2" x 1/4" x 1/4" FLAT BAR STOCK
9	BRACE	2	50" x 1 1/2" x 0.08 STL. SQ. TUBE
10	NEOPRENE INSERT	1	12" x 3/4" x 1/8"
11	TUBE	1	15" x 1 1/2" x 0.08 STL. SQ. TUBE
12	NEOPRENE INSERT	1	12" x 1" x 1/8"
13	TUBE	2	18" x 1 1/2" x 0.08 STL. SQ. TUBE
14	BRACE	2	23 13/16" x 1 1/2" x 0.08 STL. SQ. TUBE
15	TUBE	2	34 1/2" x 1 1/2" x 0.08 STL. SQ. TUBE
16	PRISM BASE SUPPORT	1	ASSEMBLY
17	TUBE	2	35 1/2"x1 1/2"x0.08 STL. SQ. TUBE
18	UPPER CLAMP BRT.	1	ASSEMBLY
19	NEOPRENE INSERT	1	10" x 1-1/2" x 1/8"
20	1/2"-13x10" HEX SCREW	2	STEEL Z.P
21	1/2" FLAT WASHER	4	STEEL Z.P 9701-0039
22	PLATE	1	14 5/8"x8"x1/4"
23	TUBE	2	18" x 1 1/2" x 0.080 SQ. STL. TUBE
24	1/2" - 13 HEX NUT	2	
25	1/2" - 13 x 8" HEX BOLT	2	9601-0045
26	5/8"-18x6 HEX SCREW	2	MACHINE THREADS OFF LAST 1/2" TO 0.55#
27	SIDE	1	14"x3"x1/2" BAR STOCK
28	FLOATING PLATE	1	7 1/2"x2"x1/2" BAR STOCK
29	ROLL PIN	2	1/2" DIA.x2"
30	SLIDE	1	15"x2"x1" ALUMINUM BAR
31	SIDE	2	9 7/8"x3"x1/2" FLAT BAR STOCK
32	TOP PLATE	1	14"x2"x1/2" FLAT BAR STOCK
33	SIDE	1	14"x2 1/8"x1" FLAT BAR STOCK
34	PLATE	2	12"x2"x1/2" FLAT BAR STOCK
35	SHCS	2	1/4"-20x1"
36	HOLDER	2	2"x1/2"x1/2" STEEL BAR
37	LOADING BLOCK	1	STEEL
38	JOINT	1	2"x1"x1/4"

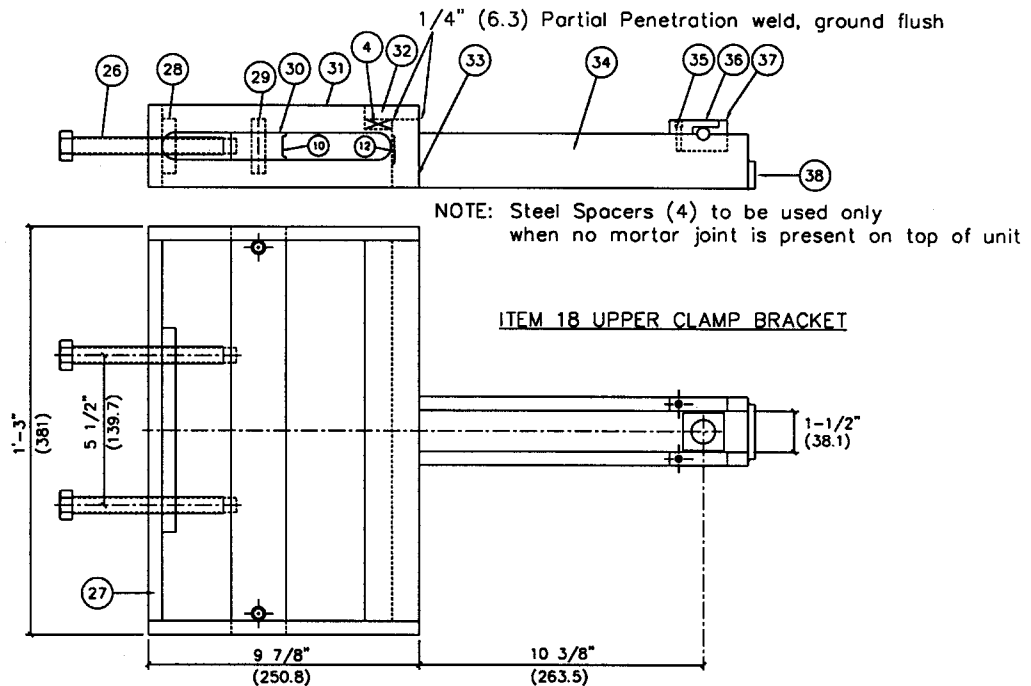

FIG. 3 Material List and Detail Drawings

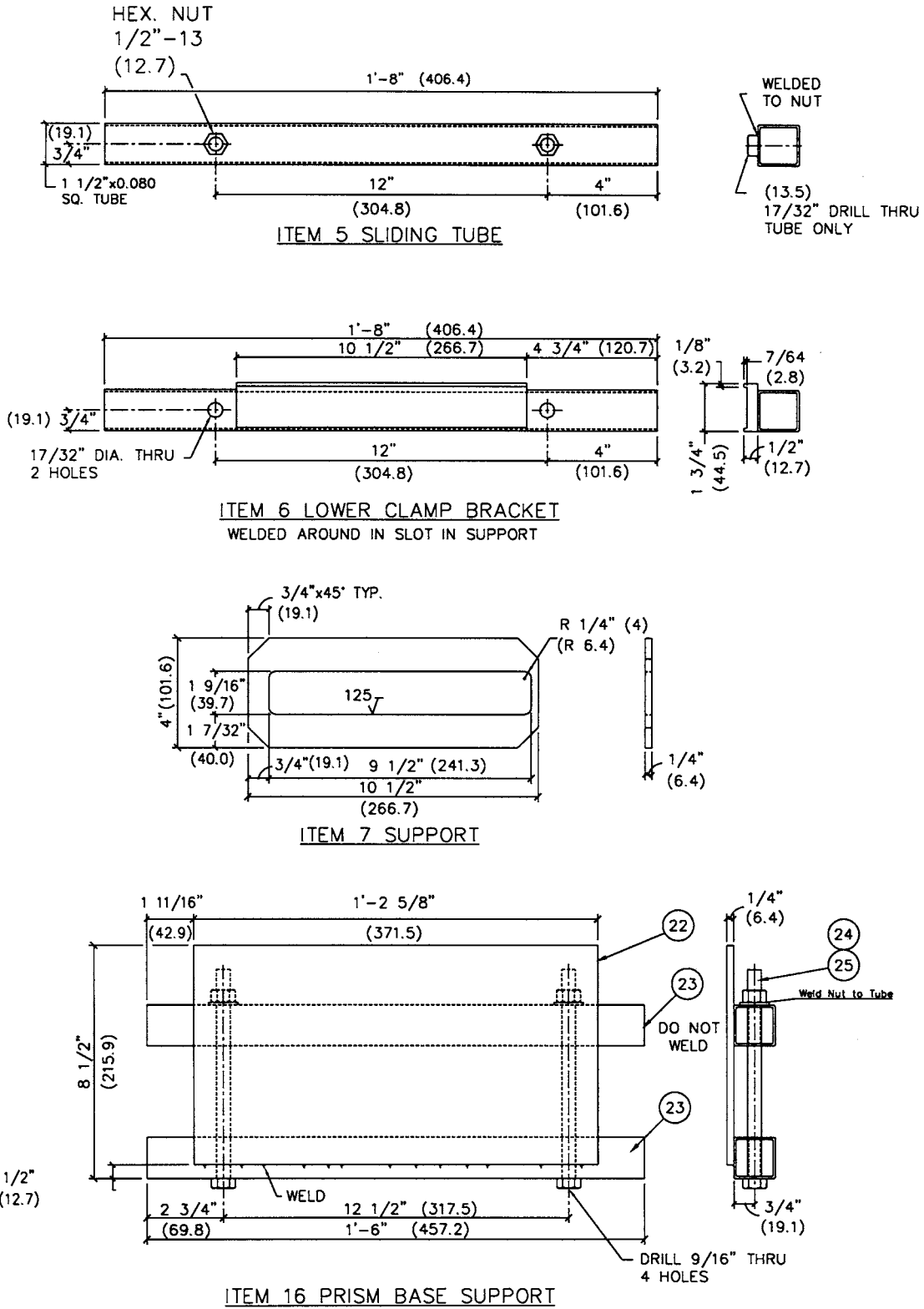

FIG. 4 Detail Drawings of Bond Wrench

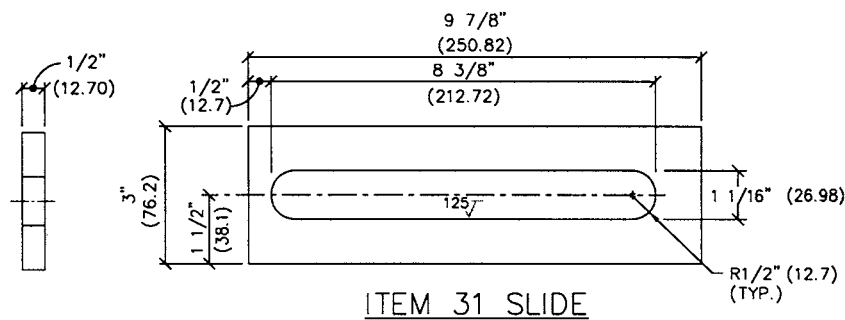
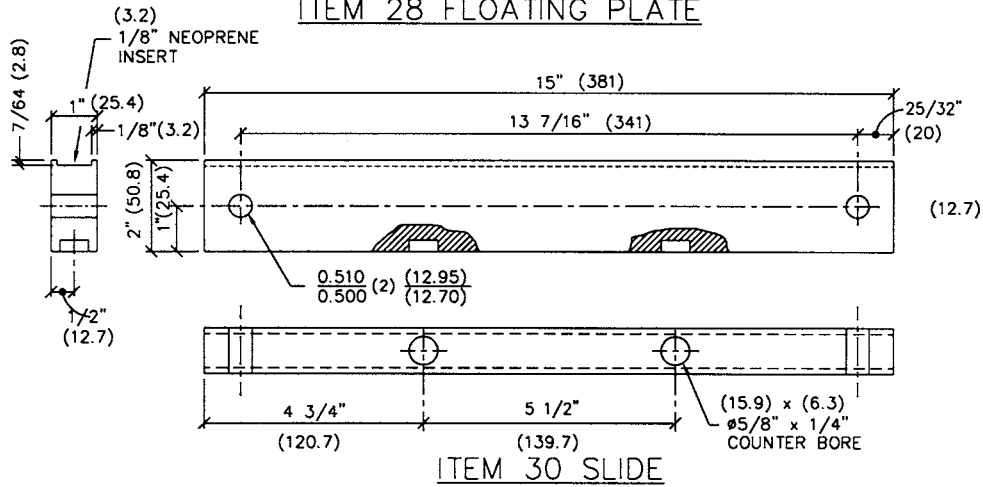
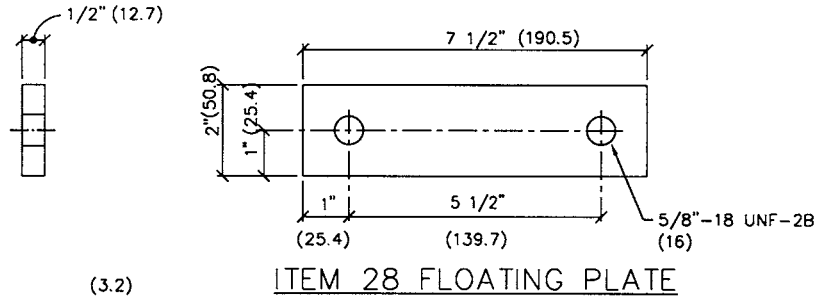
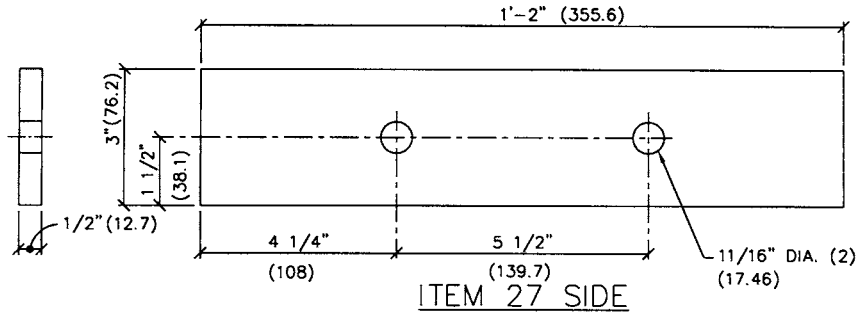

FIG. 4 Detail Drawings of Bond Wrench (continued)

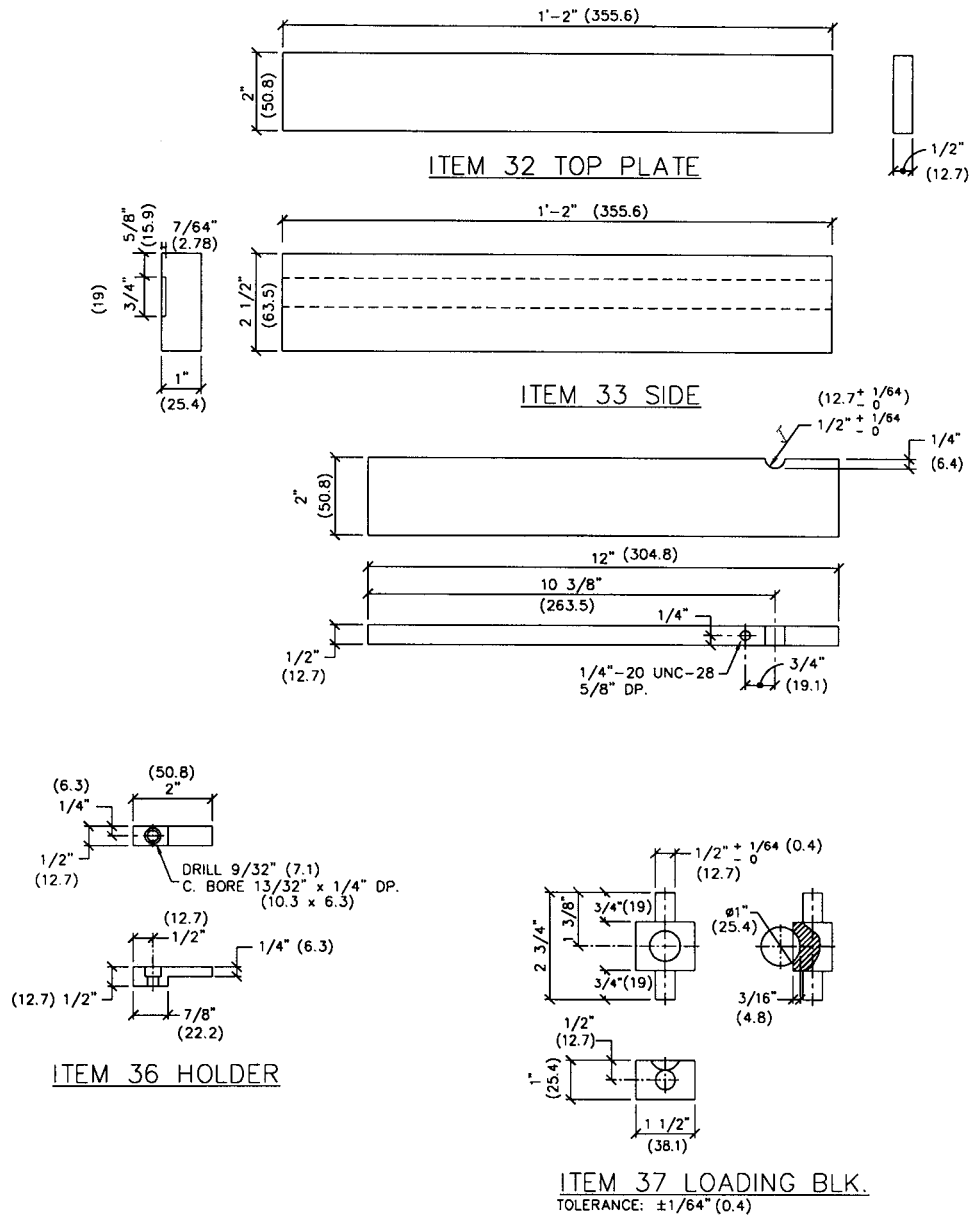

FIG. 4 Detail Drawings of Bond Wrench (continued)

8. Calculations

8.1 For specimens built of solid masonry units (at least 75 % net area), calculate the gross area flexural strength as follows:

$$F_g = \frac{6(PL + P_l L_l)}{bd^2} - \frac{(P + P_l)}{bd} \tag{1}$$

where:

- F_g = gross area flexural tensile strength, psi (MPa),
- P = maximum applied load, lbf (N),
- P_l = weight of loading arm, lbf (N), (see Appendix X1),
- L = distance from center of prism to loading point, in. (mm),
- L_l = distance from center of prism to centroid of loading arm, in. (mm) (see Appendix X1),
- b = cross-sectional width of the mortar-bedded area, measured perpendicular to the loading arm of the upper clamping bracket as determined in 8.3 (see Fig. 5), and
- d = cross-sectional depth of the mortar-bedded area, measured parallel to the loading arm of the upper clamping bracket as determined in 8.4 (see Fig. 5).

8.2 For prisms built with hollow masonry units (less than 75 % net area), calculate the net area flexural tensile stress as follows:

$$F_n = \frac{PL + P_l L_l}{S} - \frac{P + P_l}{A_n} \tag{2}$$

where:

- F_n = net area flexural tensile strength, psi (MPa),
- S = section modulus of the net bedded area of the prism, in.³ (mm³), and
- A_n = net bedded area of the prism, in.² (mm²).

8.2.1 If hollow masonry prisms are constructed using face shell mortar bedding in which opposing face shells are equal in

thickness (within 1/8 in. (3 mm)) and are symmetrical about the centroidal axis of the prism, calculate the section properties of the prism as follows:

$$A_n = 2b(t_{fs}) \tag{3}$$

$$S = I / c$$

$$c = d / 2$$

$$I = 2 \left[\frac{b \times (t_{fs})^3}{12} + (b \times t_{fs}) \times \left(c - \frac{t_{fs}}{2} \right)^2 \right] = \frac{b(t_{fs})^3}{6} + \frac{bt_{fs} \times (d - t_{fs})^2}{2}$$

- A_n = net bedded area of the prism, in.² (mm²),
- S = section modulus of the net bedded area of the prism, in.³ (mm³),
- I = moment of inertia of the net bedded area of the prism, in.⁴ (mm⁴),
- c = distance from the centroid to the most extreme tension fiber of the mortar bedded area, in. (mm),
- b = cross-sectional width of the mortar-bedded area, measured perpendicular to the loading arm of the upper clamping bracket as determined in 8.3 (see Fig. 6),
- d = cross-sectional depth of the mortar-bedded area, measured parallel to the loading arm of the upper clamping bracket as determined in 8.4 (see Fig. 6), and
- t_{fs} = minimum face shell thickness of unit (determined in accordance with Test Methods C 140), in. (mm) (see Fig. 6).

8.3 Determine the cross-sectional width of the mortar-bedded area, measured perpendicular to the loading arm of the upper clamping bracket, b , as follows:

8.3.1 For clay masonry units, determine the length of the unit using Test Methods C 67. This length shall be considered as the cross-sectional width of the mortar-bedded area, b , as defined in this test method.

8.3.2 For concrete masonry units, determine the length of the unit using Test Methods C 140. This length (referred to as L in Test Methods C 140) shall be considered as the cross-sectional width of the mortar-bedded area, b , as defined in this test method.

8.4 Determine the cross-sectional depth of the mortar-bedded area, measured parallel to the loading arm of the upper clamping bracket, d , as follows:

8.4.1 For clay masonry units, determine the width of the unit using Test Methods C 67. This width shall be considered as the cross-sectional depth of the mortar-bedded area, d , as defined in this test method.

8.4.2 For concrete masonry units, determine the width of the unit using Test Methods C 140. This width (referred to as W in Test Methods C 140) shall be considered as the cross-sectional depth of the mortar-bedded area, d , as defined in this test method.

9. Report

9.1 Report the following information:

9.1.1 Identification number of prism,

9.1.2 Average prism dimensions to the nearest 0.05 in. (1.0 mm) including width, depth, and height,

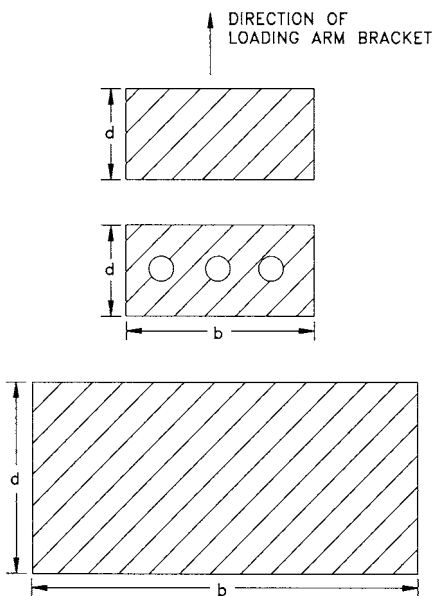

FIG. 5 Example Cross-Section of Solid Masonry Units

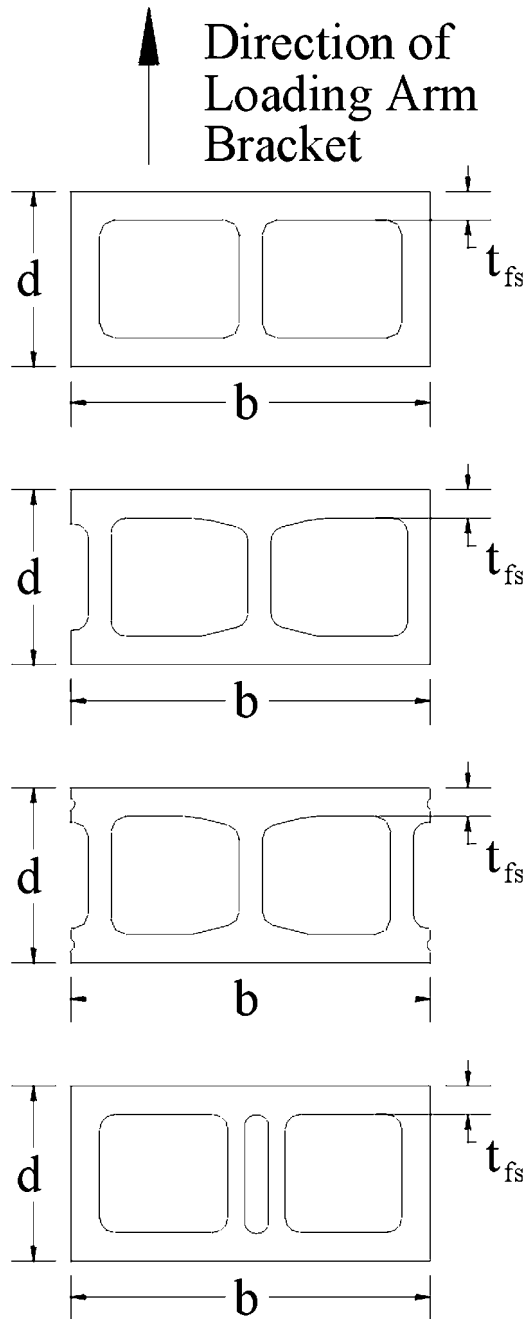

FIG. 6 Example Dimensions of Hollow Masonry Units Used to Determine Section Properties

9.1.3 Weight of specimen, lbf (N),

9.1.4 Individual and average gross or net area flexural tensile stress calculated to the nearest psi (MPa), standard deviation, and position of the joint tested within the specimen. If a mortar joint breaks during the handling of the specimen and tightening of the loading clamps but before additional load is applied by the testing apparatus, report which joint(s) broke prematurely but do not include them in the calculation of the flexural tensile strength average and standard deviation. The top mortar joint shall be designated joint Number 1, the second, Number 2, etc. Measured loads and calculation shall also be included,

9.1.5 Description of failure, especially indicating whether failure occurred at the top or bottom of the mortar joint, or both,

9.1.6 Sketch or photo of masonry unit showing core configuration and mortar bedded area, full or face shell, and

9.1.7 Description of bonding pattern, joint tooling, location of tooled joint during test, and joint thickness.

9.2 Where specified the report shall include the following:

- 9.2.1 Type and mix proportions of mortar,
- 9.2.2 Compressive strength of mortar, psi (MPa),
- 9.2.3 Initial flow or cone penetration of mortar as used,
- 9.2.4 Water retention of mortar,
- 9.2.5 Mortar air content,
- 9.2.6 Physical properties of masonry units, and
- 9.2.7 Curing history and age of specimen at each break.

10. Precision and Bias

10.1 Insufficient data is currently available for a precision and bias statement.

11. Keywords

- 11.1 assemblies; bond; flexural; masonry; tensile

APPENDIX
(Nonmandatory Information)
X1. DETERMINATION OF WEIGHT AND CENTROID OF UPPER CLAMPING BRACKET

X1.1 Side and plan views of the upper clamping bracket are illustrated in Fig. X1.1. The weight (P) of the upper clamping bracket including the loading arm, is determined by weighing to the nearest 25 g or oz. A brick weighing within 0.1 lbf (0.44 N) and having a thickness (d) within 0.25 in. (6 mm) of those being tested must be clamped into the position shown for the brick in Fig. X1.1 before determining the weight and centroid of the upper clamping bracket. The centroid of the upper clamping bracket is located by positioning the bracket upside down upon a knife edge balance. Using a trial and error

method, vary the position of the frame upon the knife edge balance. The location of the frame centroid is the point where the frame balances upon the knife edge.

X1.1.1 Determine L for use in Eq 1 and Eq 2 by the following expression:

$$L_l = r + d/2 \quad (X1.1)$$

where:

r = is shown in Fig. X1.1.

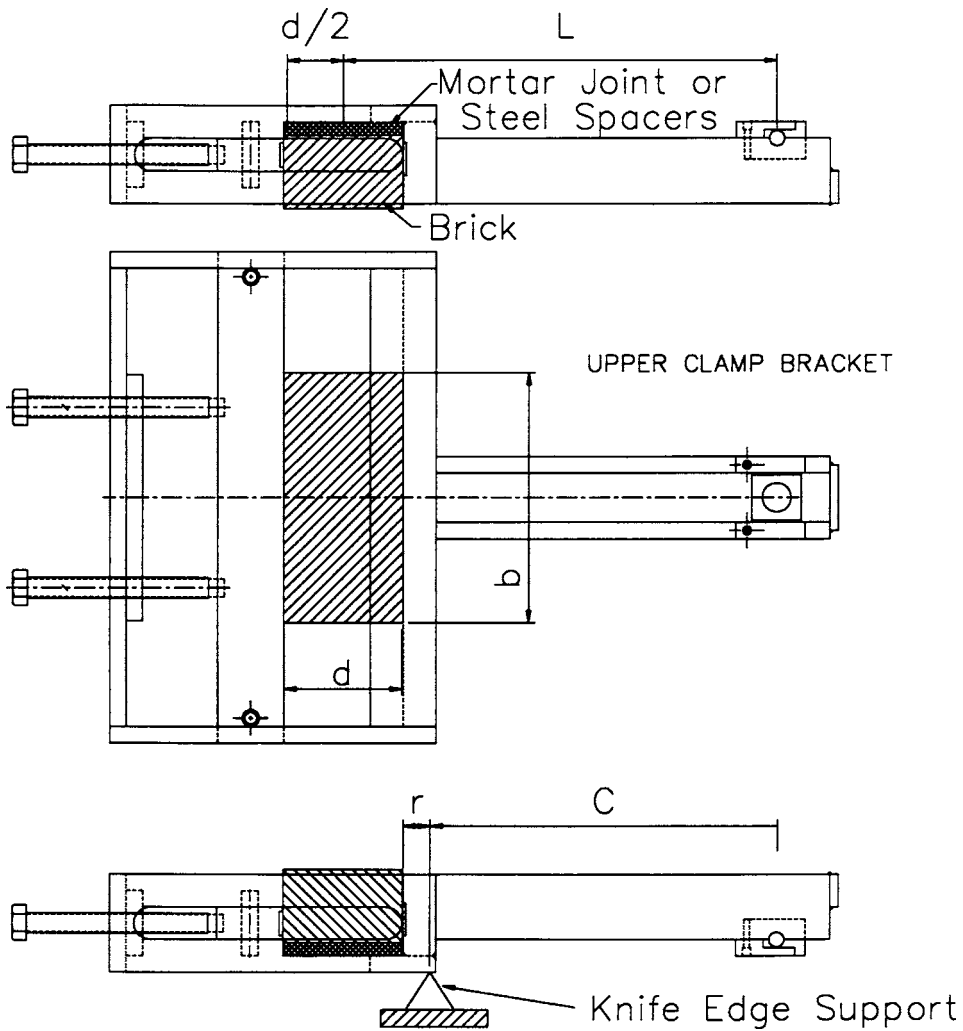

FIG. X1.1 Upper Clamping Bracket

SUMMARY OF CHANGES

Committee C15 has identified the location of selected changes to this standard since the last version (C 1072 - 05b) that may impact the use of this standard. (Approved June 1, 2006.)

(1) Section 6.1 was changed to lower the minimum width of the specimen from 4.0 to 3.5 in.

Committee C15 has identified the location of selected changes to this standard since the last version (C 1072 – 05a) that may impact the use of this standard. (Approved Nov. 15, 2005.)

(1) Section 9.1.4 was changed to clarify what to do with mortar joints that break during setup of the specimen.

Committee C15 has identified the location of selected changes to this standard since the last version (C 1072 – 05) that may impact the use of this standard. (Approved May 15, 2005.)

(1) Section 6.1 was changed to clarify that a test specimen can be a set of more than one prism and to limit the height of the prism to five joints.

Committee C15 has identified the location of selected changes to this standard since the last version (C 1072 – 00a) that may impact the use of this standard. (Approved Feb. 1, 2005.)

(1) 2.1 and 6.3 were changed to reference Practice C 1532.
(2) 6.2 was changed to make the minimum number of joints tested to be 15 for fabricated prisms and 5 for prisms obtained from existing masonry.

(3) 6.3 was changed to make the fabrication procedures more consistent with those in Test Method C 1357 by requiring bag curing unless specified otherwise and not requiring that the two loose units be placed on the top of the prisms.

ASTM International takes no position respecting the validity of any patent rights asserted in connection with any item mentioned in this standard. Users of this standard are expressly advised that determination of the validity of any such patent rights, and the risk of infringement of such rights, are entirely their own responsibility.

This standard is subject to revision at any time by the responsible technical committee and must be reviewed every five years and if not revised, either reapproved or withdrawn. Your comments are invited either for revision of this standard or for additional standards and should be addressed to ASTM International Headquarters. Your comments will receive careful consideration at a meeting of the responsible technical committee, which you may attend. If you feel that your comments have not received a fair hearing you should make your views known to the ASTM Committee on Standards, at the address shown below.

This standard is copyrighted by ASTM International, 100 Barr Harbor Drive, PO Box C700, West Conshohocken, PA 19428-2959, United States. Individual reprints (single or multiple copies) of this standard may be obtained by contacting ASTM at the above address or at 610-832-9585 (phone), 610-832-9555 (fax), or service@astm.org (e-mail); or through the ASTM website (www.astm.org).