



Standard Test Method for Vacuum Drainage of Asbestos-Cement Mixes¹

This standard is issued under the fixed designation C 1119; the number immediately following the designation indicates the year of original adoption or, in the case of revision, the year of last revision. A number in parentheses indicates the year of last reapproval. A superscript epsilon (ϵ) indicates an editorial change since the last revision or reapproval.

^{ε1} NOTE—Asbestos warning was moved from 8.1 to 1.3 in September 2004.

1. Scope

1.1 This test method describes a laboratory procedure for the evaluation of asbestos fiber by measuring the rate of drainage under suction, of an asbestos-cement mixture.

1.2 The values stated in SI units are to be regarded as the standard. The values given in parentheses are for information only.

1.3 **Warning**—Breathing of asbestos dust is hazardous. Asbestos and asbestos products present demonstrated health risks for users and for those with whom they come into contact. In addition to other precautions, when working with asbestos-cement products, minimize the dust that results. For information on the safe use of chrysotile asbestos, refer to “Safe Use of Chrysotile Asbestos: A Manual on Preventive and Control Measures.”²

1.4 *This standard does not purport to address all of the safety concerns, if any, associated with its use. It is the responsibility of the user of this standard to establish appropriate safety and health practices and determine the applicability of regulatory limitations prior to use. See Note 1 and 1.3 for specific hazard warnings.*

2. Referenced Documents

2.1 ASTM Standards:³

- C 150 Specification for Portland Cement
- C 430 Test Method for Fineness of Hydraulic Cement by the 45- μm (No. 325) Sieve
- C 1124 Test Method for Kerosene Retention of Asbestos
- D 2590 Test Method for Sampling Chrysotile Asbestos
- D 2946 Terminology for Asbestos and Asbestos-Cement Products

¹ This test method is under the jurisdiction of ASTM Committee C-17 on Fiber-Reinforced Cement Products and is the direct responsibility of Subcommittee C17.03 on Asbestos-Cement Sheet Products and Accessories.

Current edition approved June 1, 2004. Published July 2004. Originally approved in 1989. Last previous edition approved in 1999 as C 1119 – 90 (1999).

² Available from The Asbestos Institute, http://www.chrysotile.com/en/sr_use/manual.htm.

³ For referenced ASTM standards, visit the ASTM website, www.astm.org, or contact ASTM Customer Service at service@astm.org. For *Annual Book of ASTM Standards* volume information, refer to the standard's Document Summary page on the ASTM website.

D 3752 Test Method for Strength Imparted by Asbestos to a Cement Matrix

D 3879 Test Method for Sampling Amphibole Asbestos

D 3880 Test Method for Asbestos-Fiber Strength Unit

E 177 Practice for Use of the Terms Precision and Bias in ASTM Test Methods

2.2 ACS Document:

Specifications of the Committee on Analytical Reagents of the American Chemical Society⁴

3. Terminology

3.1 For definitions, refer to Terminology D 2946.

4. Summary of Test Method

4.1 The fiber to be evaluated is fiberized to simulate the specific surface area at which it is used in the industrial process, and it is added to the same mix using representative ingredients and process water. If the latter is not available, saturated water may be substituted (see 7.7). The slurry is dewatered on a 177- μm (No. 80) screen cloth (or in accordance with the Apparatus Section of Test Method D 3752) under a vacuum of 90 kPa (70 cm Hg). The end point is determined as the point when air begins to pass through the filter cake, and the suction drops abruptly. The time taken to reach the end point is recorded and this is a function of the drainage rate of the mix.

5. Significance and Use

5.1 This test method can be used to estimate the speed of drainage and the rate of production of products from the fiber evaluated, in industrial applications. It may be applied to single grades of fiber, or to fiber blends, together with the same binder system and process water used in the process under evaluation.

6. Apparatus

6.1 *Drainage Apparatus*, as described in Fig. 1 and Fig. 2. The funnel shown in Fig. 1 shall be cemented to the bottom of Part 3 of Fig. 2 to give an air-tight seal. Alternatively, the

⁴ Available from American Chemical Society, 1155 16th St. NW, Washington, DC 20036.

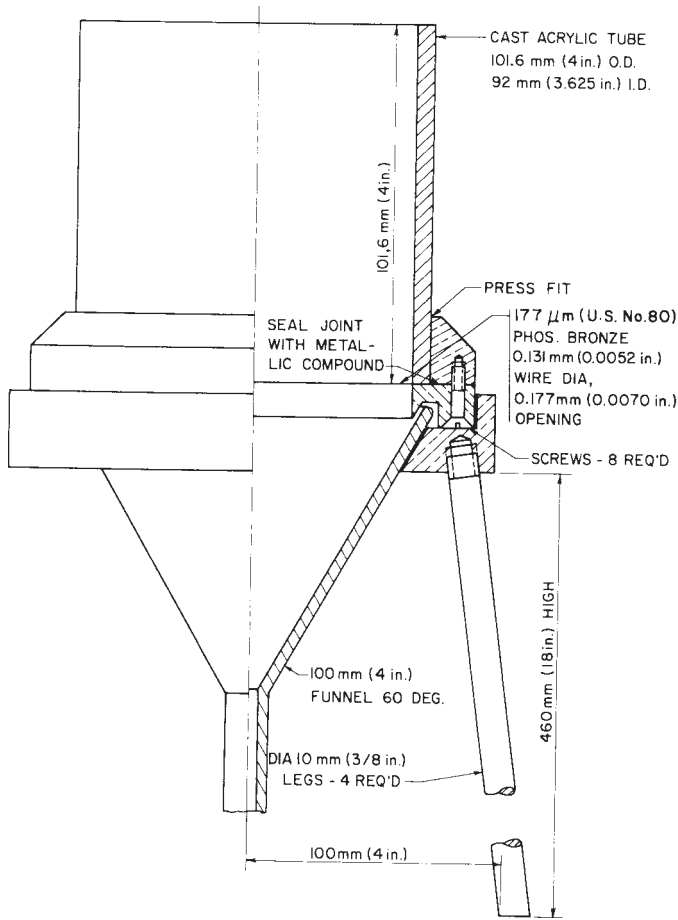

FIG. 1 Drainage Funnel Assembly

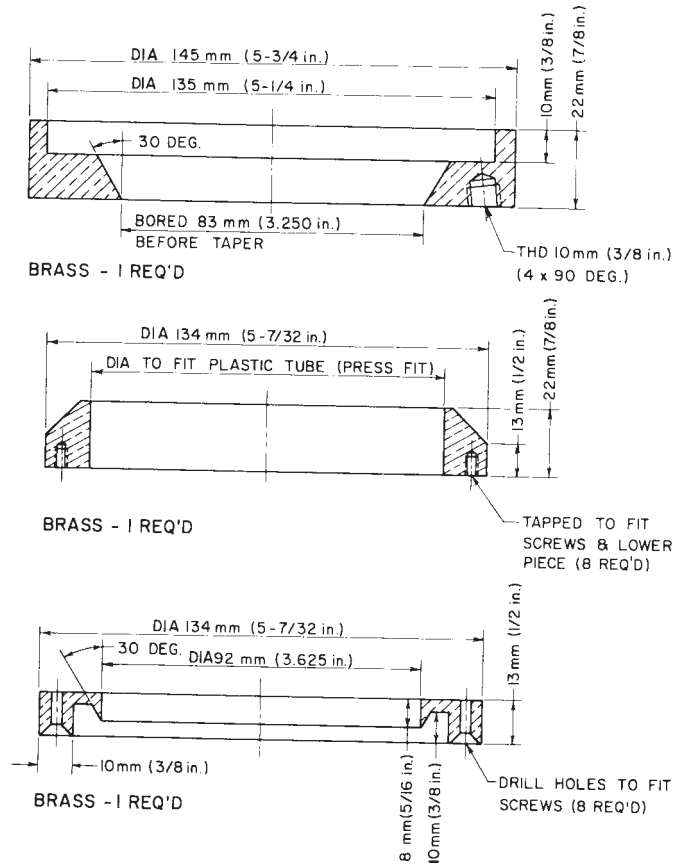

FIG. 2 Drainage Funnel Detail

apparatus described in Test Method C 1124 or in Test Method D 3752, may be used.

6.2 *Vacuum-Actuated Switch*—Set to activate an electric timer when the pressure is between 50 kPa (40 cm Hg vacuum) and 8 kPa (70 cm Hg vacuum). This switch shall be located at the discharge of the drainage funnel, together with a manometer of from 0 to 50 kPa absolute (0 to 76 cm Hg vacuum) capacity, and a water trap with a capacity of 500 cm.

6.3 *Wet Mixer*, as shown in Fig. 3, Fig. 4, and Fig. 5, capable of maintaining a speed of 62.8 ± 2.6 rad/s (600 ± 25 r/min) under load. Alternatively, the mixing apparatus, as described in Test Method D 3880, may be used.

6.3.1 The impeller shall rotate clockwise when looking from above, and the vanes shall be pitched so as to impel the slurry downward.

6.3.2 Maximum clearance between the impeller and the conical wall of the wet mixer shall be set at 6.3 mm.

6.3.3 The distance between the bottom of the impeller and the top of the stopper shall be set at 1 ± 0.1 cm.

6.4 *Source of Vacuum*, at 90 ± 0.2 kPa (70 ± 0.2 cm Hg).

6.5 *Fiberizer*, such as described in Test Method D 3752. This is needed only if the fiber to be evaluated is not available at the required degree of fiberization.

7. Reagents and Materials

7.1 *Reagents and Materials*—(See Note 1 and Note 2.)

7.2 *Calcium Hydroxide* $[\text{Ca}(\text{OH})_2]$, conforming to the ACS Specifications.⁶ Other grades may be used provided it is first ascertained that the reagents are of sufficiently high purity to permit their use without lowering the accuracy of the determination.

7.3 *Calcium Sulfate (Gypsum)* $(\text{CaSO}_4 \cdot 2\text{H}_2\text{O})$, conforming to the ACS specifications.⁶

NOTE 1—Calcium hydroxide and calcium sulfate are required only if white water from the process evaluated is not available.

7.4 *Silica*, from the same source that used in the process being evaluated, or alternatively ground quartz (SiO_2), conforming to the following specifications:

SiO_2 content; 99 percent minimum.

7.4.1 Wet sieve analysis by the technique described in Test Method C 430.

U.S. Sieve No.	Minimum Percent Passing
80	99
100	90
200	85

NOTE 2—Silica is required only when testing asbestos-cement mixes intended for autoclave curing.

NOTE 3—**Caution**—When using silica, use reasonable precautions to avoid creating dust. Prolonged or frequent breathing of significant concentrations of airborne silica may cause serious bodily harm.

7.5 Cellulose and all other additives identical to those used in the industrial process.

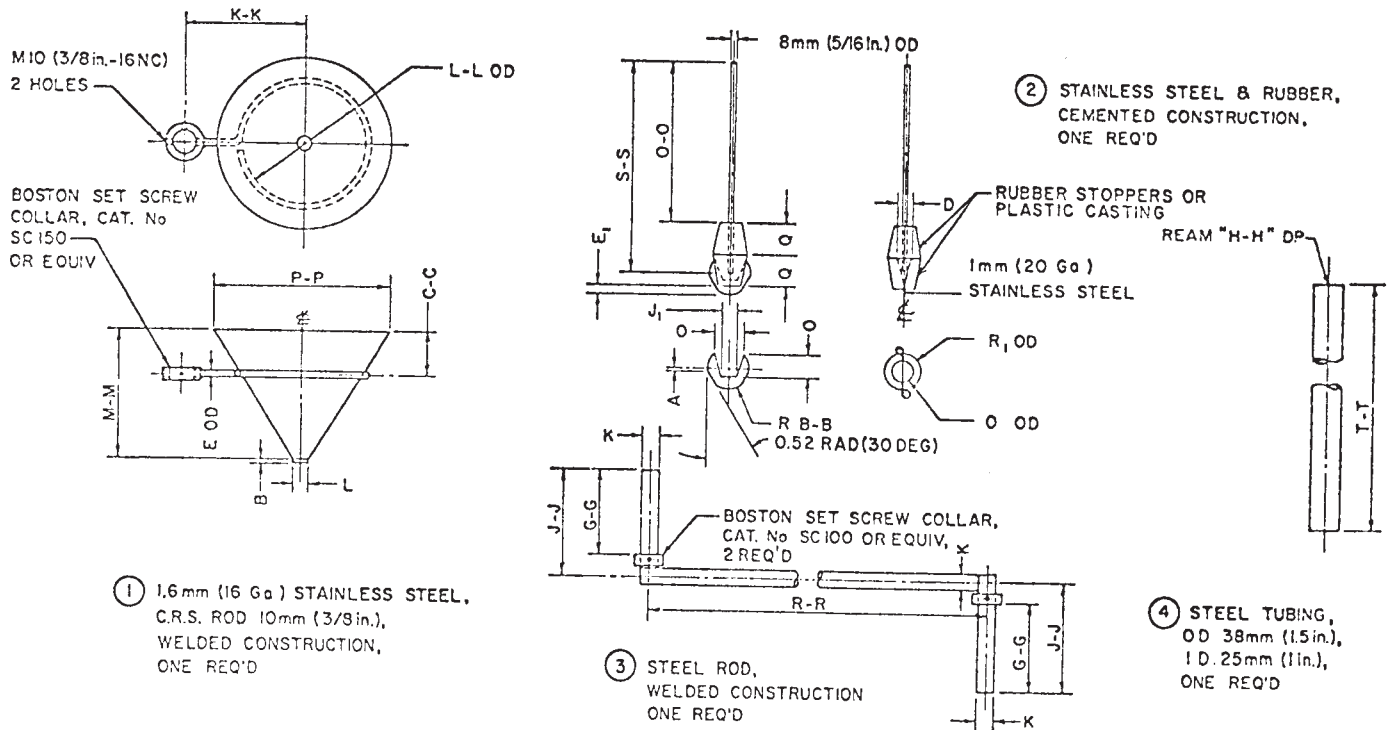

LEGEND

Dimension	mm	in.	Dimension	mm	in.	Dimension	mm	in.
A	3	1/8	O	38	1 1/2	K-K	165	6 1/2
B	5	3/16	Q	46	1 3/16	L-L	170	6 1/16
D	18	23/32	R ₁	48	1 57/64	M-M	180	7 3/32
E	10	3/8	B-B	62	2 7/16	O-O	230	9
E ₁	10	25/64	C-C	63	2 1/2	P-P	240	9 7/16
J ₁	23	29/32	G-G	130	5	S-S	310	12
K	25	1	H-H	155	6	T-T	420	16 1/2
L	28	1 1/16						

FIG. 3 Cone Mixer and Impeller Detail

7.6 Portland Cement or Pozzolan Cement, from the same source as that used in the industrial process. Alternatively, use Type I cement conforming to Specification C 150.

7.7 Saturated Water:

7.7.1 If white water from the process is not available, prepare saturated water by adding 2 kg of Ca(OH)₂ and 3 kg of CaSO₄·2H₂O per m³ of distilled water at 24 ± 1°C.

7.7.2 Allow to stand 24 h agitating the water from time to time.

7.7.3 Siphon off the saturated water into clean containers.

7.7.4 If the temperature of the saturated water fluctuates, precipitation of the dissolved salts may occur. For this reason, it is preferable to filter this water at the point of use, for wet mixing purposes.

8. Hazards

8.1 Warning—see 1.3.

9. Sampling

9.1 Take a sample in accordance with Test Method D 2590 for chrysotile asbestos, or in accordance with Test Method D 3879 for amphibole asbestos.

9.2 Test Specimen and Sample:

9.2.1 The mass of fiber or fiber blend required per specimen is 10 ± 0.05 g per specimen. Two specimens per sample are normally required.

9.2.2 The fiber shall be fiberized to the same specific surface area as that at which it will be utilized in the process under evaluation.

10. Procedure

10.1 Fiberize the fiber, if required, as described in Test Method D 3752.

10.2 Place the fiber or fiber-blend specimen in the wet mixer together with the following ingredients:

Material	Quantity
Cement	44 ± 0.05 g
Silica (if used) ^A	29 ± 0.05 g
White water	470 ± 1 cm ³

^A If silica is not used, substitute an equal mass of additional cement.

10.3 Mix for 2 min.

10.4 Transfer the slurry to the drainage apparatus. Immediately, the slurry will coat the screen thus preventing the passage of air, and creating a vacuum. When the absolute pressure decreases to 50 kPa (vacuum increases to 40 cm Hg) the electric timer will start. The absolute pressure will continue to

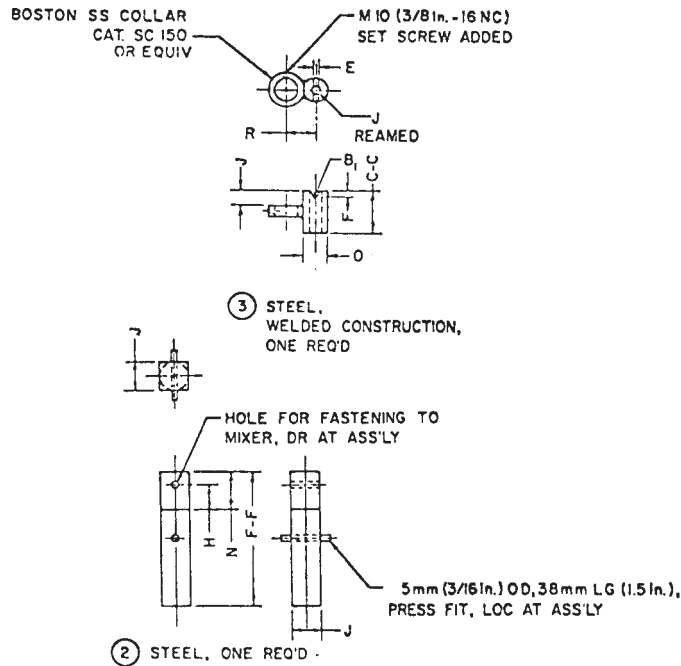

LEGEND

Dimension	mm	in.	Dimension	mm	in.	Dimension	mm	in.
B ₁	5	3/16	O	38	1 1/2			
E	10	3/8	R	48	1 7/8	F-F	110	4 1/4
F	11	7/16						
H	20	3/4						
J	22	7/8	C-C	63	2 1/2			
N	32	1 1/4						

FIG. 4 Additional Wet Mixer Details

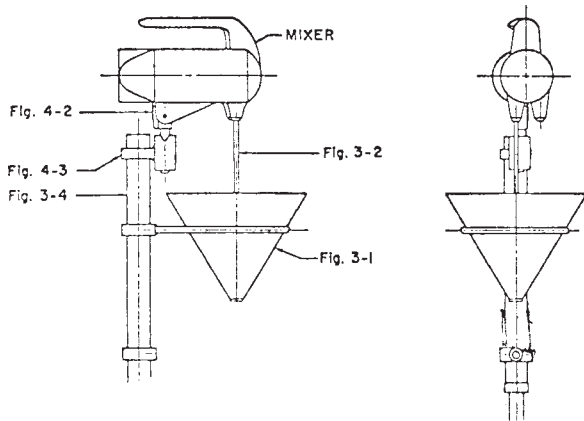

FIG. 5 Wet Mixer Assembly

decrease to the set point of 8 ± 0.02 kPa (vacuum will increase to 70 ± 0.2 cm Hg), and remain at that point until the water has drained, and air can enter the system by passing through the filter cake. Then the vacuum will be broken abruptly, and the timer will stop when the absolute pressure reaches 50 kPa (vacuum of 40 cm Hg).

10.5 Record this drainage time to the nearest second, and test a second specimen.

11. Calculation or Interpretation of Results

11.1 Calculate the deviation from the mean of the two values recorded, and if this exceeds $\pm 6\%$, carry out an additional trial.

12. Report

12.1 Report the average of two, or three trials, as the case may be.

12.2 Fully identify the sample as to designation and origin.

13. Precision and Bias

13.1 *Precision:*

13.1.1 The single-apparatus multi-operator precision is $\pm 5.03\%$ (two sigma limits) as defined in Practice E 177, over the range of from 35 to 430 s.

13.1.2 The interlaboratory precision remains to be estimated to comply with precision statement requirements.

13.2 *Bias*—No justifiable statement can be made on the bias of this test method since the true value of the property measured cannot be established by an accepted referee method.

14. Keywords

14.1 asbestos; asbestos-cement; dewatering; drainage; drainage properties; drainage rate; drainage speed; drainage velocity; suction; vacuum drainage

 C 1119 – 90 (2004)^{e1}

ASTM International takes no position respecting the validity of any patent rights asserted in connection with any item mentioned in this standard. Users of this standard are expressly advised that determination of the validity of any such patent rights, and the risk of infringement of such rights, are entirely their own responsibility.

This standard is subject to revision at any time by the responsible technical committee and must be reviewed every five years and if not revised, either reapproved or withdrawn. Your comments are invited either for revision of this standard or for additional standards and should be addressed to ASTM International Headquarters. Your comments will receive careful consideration at a meeting of the responsible technical committee, which you may attend. If you feel that your comments have not received a fair hearing you should make your views known to the ASTM Committee on Standards, at the address shown below.

This standard is copyrighted by ASTM International, 100 Barr Harbor Drive, PO Box C700, West Conshohocken, PA 19428-2959, United States. Individual reprints (single or multiple copies) of this standard may be obtained by contacting ASTM at the above address or at 610-832-9585 (phone), 610-832-9555 (fax), or service@astm.org (e-mail); or through the ASTM website (www.astm.org).