



Standard Test Method for Turner and Newall (T and N) Wet-Length Classification of Asbestos¹

This standard is issued under the fixed designation C 1121; the number immediately following the designation indicates the year of original adoption or, in the case of revision, the year of last revision. A number in parentheses indicates the year of last reapproval. A superscript epsilon (ϵ) indicates an editorial change since the last revision or reapproval.

^{e1} NOTE—Asbestos warning was moved from 7.1 to 1.6 in September 2004.

1. Scope

1.1 This test method covers the operation of the Turner and Newall (T and N) wet sieving classifier for asbestos,² and a procedure for the determination of fiber length distribution and fines (defined in Terminology D 2946) content of milled asbestos fiber ($-74\ \mu\text{m}$ (200 mesh)) sieve described in Specification E 11.

1.2 For purposes of estimating length distribution, the test is limited to samples free from excessive quantities of non-fibrous particles or contaminants. Quantities exceeding 0.05 g retained in any given length fractions are considered excessive.

1.3 For comparisons between different fiber grades, only those specimens which have approximately the same degree of fiberization as determined by Test Methods D 2752 will give completely meaningful results.

1.4 This test method is not applicable to ultrafine grades of asbestos powders which contain little or no fibers retained on a $74\text{-}\mu\text{m}$ (200 mesh) sieve. This method is restricted to Quebec Standard³ grades 4A to 7D inclusive as determined by Test Method D 3639.

NOTE 1—This is an alternative procedure to Test Method D 2589.

1.5 The values stated in SI units are to be regarded as the standard. The values given in parentheses are for information only.

1.6 **Warning**—Breathing of asbestos dust is hazardous. Asbestos and asbestos products present demonstrated health risks for users and for those with whom they come into contact. In addition to other precautions, when working with asbestos-

cement products, minimize the dust that results. For information on the safe use of chrysotile asbestos, refer to “Safe Use of Chrysotile Asbestos: A Manual on Preventive and Control Measures.”⁴

1.7 *This standard does not purport to address all of the safety concerns, if any, associated with its use. It is the responsibility of the user of this standard to establish appropriate safety and health practices and determine the applicability of regulatory limitations prior to use.* For a specific hazard statement, see 1.6.

2. Referenced Documents

2.1 *ASTM Standards:*⁵

D 2589 Test Method for McNett Wet Classification of Asbestos Fiber

D 2590 Test Method for Sampling Chrysotile Asbestos

D 2752 Test Methods for Air Permeability of Asbestos Fibers

D 2946 Terminology Relating to Asbestos

D 3639 Test Method for Classification of Asbestos Fibers by the Quebec Standard Test

D 3879 Test Method for Sampling Amphibole Asbestos

E 11 Specification for Wire-Cloth Sieves for Testing Purposes

E 177 Practice for Use of the Terms Precision and Bias in ASTM Test Methods

2.2 *Other Standard:*

Quebec Asbestos Mining Association (QAMA) Standard Designation of Chrysotile Asbestos Grades³

3. Terminology

3.1 *Definitions*—Refer to Terminology D 2946.

¹ This test method is under the jurisdiction of ASTM Committee C17 on Fiber-Reinforced Cement Products and is the direct responsibility of Subcommittee C17.03 on Asbestos - Cement Sheet Products and Accessories.

Current edition approved June 1, 2004. Published July 2004. Originally approved in 1989. Last previous edition approved in 1999 as C 1121 – 90 (1999).

² The apparatus is supplied, on a non-profit basis, as a service to the asbestos industry by TAF International, Bowdon House, Ashburton Rd. W, Trafford Park, Manchester M170RQ, England.

³ Available from the Asbestos Institute, 1300 Sherbrooke St. West, Suite 412, Montreal QC, Canada H3A 2M8.

⁴ Available from The Asbestos Institute, http://www.chrysotile.com/en/sr_use/manual.htm.

⁵ For referenced ASTM standards, visit the ASTM website, www.astm.org, or contact ASTM Customer Service at service@astm.org. For *Annual Book of ASTM Standards* volume information, refer to the standard's Document Summary page on the ASTM website.

4. Summary of Test Method

4.1 A weighed specimen of asbestos fiber is dispersed in water and the dispersion is allowed to flow by gravity through a series of superposed screens which rotate in a horizontal plane. The suspension flows through successively finer screens which retain the oversized fibers. The rotation of the screens distributes the incoming fiber suspension throughout the vessel, and the swirling motion created by the incoming jet of water maintains the fibers in suspension and ensures that they all encounter the screen apertures.

4.2 At the end of the test period, the screens bearing the classified fiber fractions are removed from the vessels, dried, and weighed. The -74 μm fines content is estimated by difference.

5. Significance and Use

5.1 This test method provides a simple procedure for obtaining information on the fiber length distribution of suitable asbestos fiber. The use of relatively low cost apparatus, small test specimens, and a short test period, enhance the usefulness of this test method.

5.2 Normally, results obtained by this test method are reproducible under comparable laboratory conditions. However, close agreement cannot be expected unless all deviations from the procedure, however minor, are avoided. Moreover, results for longer fiber grades are influenced to a greater extent by differences in fiber length distribution, and characteristics, than are those for shorter grades.

5.3 This test is suitable for specification acceptance and manufacturing control.

5.4 It is assumed that all undersized fibers, and only those, will pass through any given sieve aperture. However, this idealized condition is not normally achieved. Thus, results should not be misconstrued as true length distribution data.

6. Apparatus

6.1 *Wet Sieving Classifier*, consisting of four 127-mm (5-in.) diameter rotating circular vessels, the bottom of which are fitted with 98-mm (3.86-in.) diameter screens, stacked vertically and concentrically in order of diminishing screen apertures. The apparatus is fitted with stirrers to prevent screen blinding, and with spouts for conducting the drainage from each vessel to the following vessel. The lowest vessel discharges onto a 74-μm (200 mesh) sieve 203.2 mm (8 in.) in diameter, in the base of the apparatus as shown in Fig. 1.

6.1.1 The rotational speed for the sieves must be 190 + 5 rpm.

6.1.2 The stroke frequency for the agitators must be 192 + 5 strokes/min.

6.2 *Sieve Disks*—fitted with screen cloth equivalent to 2.36 mm, 1.18 mm, 600 μm, 300 μm, 74 μm, and 63 μm (US No. 8, 16, 30, 50, and 200), are required. British Standard, Tyler, and US Standard equivalent sieves are listed in Table 1.

6.3 *Test Sieve (74-μm (200 mesh))*, 203.2-mm (8-in.) diameter, as described in Specification E 11, or equivalent Tyler or British Standard for country of use.

6.4 *Sieve Disk (63 μm (U.S. No. 230))*, of finer mesh for drying 74-μm (200 mesh) fractions.

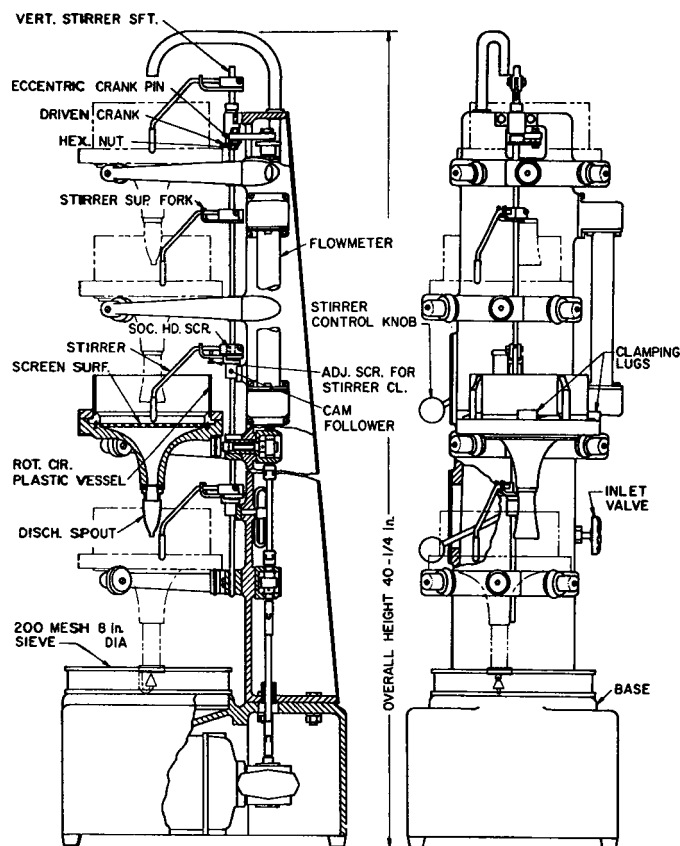

FIG. 1 Turner and Newall Classifier

TABLE 1 Sieve Equivalents

Standard Designations		Alternative Designations		Aperture Sizes ^A	
USA ^B and British	Tyler Mesh per in.	USA No.	British Mesh (approx.) per in.	mm	in. (approx.)
2.36 mm	8	8	7	2.36	0.0929
1.18 mm	14	16	14	1.18	0.0465
600 μm	28	30	25	0.60	0.0236
300 μm	48	50	52	0.30	0.0118
75 μm	200	200	200	0.075	0.00295
53 μm	250	230	240	0.063	0.00248

^A Specified apertures are now identical for the three series.

^B Identical with ASTM Standard sieves and ISO Standard apertures.

6.5 *Fraction Collector*, supplied with the apparatus, or optional suction arrangement, such as a Büchner funnel.

6.6 *Drying Apparatus*—Drying Oven (Convection Type, or Mechanical Draft) or Infrared Drying Device.

6.7 *Pressure Regulator and Filter*—if required, to ensure a constant flow of clean water to the classifier.

7. Hazards

7.1 **Warning**—see 1.6.

8. Sampling, Test Specimens, and Test Units

8.1 *Sampling*:

8.1.1 Select samples in accordance with Test Methods D 2590, in the case of chrysotile asbestos, and D 3879 for amphibole asbestos.

8.2 Test Specimen:

8.2.1 From the bulk laboratory sample, draw two specimens weighing approximately 15 g (0.5 oz). Reduce each specimen by coning and quartering to 2 ± 0.005 g.

9. Procedure

9.1 Disperse a test specimen in 400 cm³ of water in a 500-cm³ beaker and allow it to soak 4 min. After this period, stir intermittently by hand for a further period of 1 min. Stir gently and diametrically across the beaker to disperse the asbestos without excessive fiberizing action.

9.2 While the test specimen is soaking, thoroughly wet all the disks of the sieve series and fit to the classifier. Thoroughly wet the screen cloth of a clean 74- μ m (200 mesh), 203.2-mm (8-in.) diameter standard test sieve and place it in the recess in the top of the classifier base, and center the small plastic disk supplied with the apparatus atop the screen surface beneath the fourth vessel outlet.

NOTE 2—Verify the tare weight of each sieve disk daily.

9.3 Open the water control valve, start the drive motor, adjusting the flow of water through the classifier to 0.0808 cm³/s (1.28 U.S. gal/min) or the 64 graduation on the flowmeter tube when reading the top of the float, and ensure that there are no leaks caused by inadequate clamping of the sieve disks. Rectify any such leaks by unclamping the plastic vessel, readjusting the sieve disk, and reclamping the plastic vessel. Ensure that the side of the water jet impinges on the top screen about 3 mm from the inner edge of the lower bevelled part of the plastic vessel. Adjust the water spout if necessary.

NOTE 3—Check the operating water level in the top three vessels daily. The level should be to the top surface of the clamping lugs within ± 3.2 mm (0.125 in.). If the water level is high or low in any vessel, adjust the copper outlet tube of that vessel to obtain the desired level. Only very slight adjustments are necessary.

9.4 Slowly pour the water dispersion containing the test specimen from the beaker into the first (top) vessel, ensuring no overflow. Accomplish this operation within 20 to 25 s. Start the timing period at this point. Wash out any residue from the beaker with a small volume of clean water into the first vessel.

NOTE 4—A plastic wash bottle is useful for this purpose.

9.5 During the test, manually rotate the 74- μ m (200 mesh) screen slightly at 30 s intervals, recentering the plastic disk on each occasion, for improved operation and to prevent blinding. If the water level in either of the two lowest rotating sieve units rises continuously, as may happen with short or talcy grades, lower the stirrer on the appropriate sieve by pressing down on the control knob on the left-hand side of the classifier body. Immediately clear any fiber which lodges in the orifices of any of the sieving units, by means of a wire hook. A clue to this malfunction is given if the water level in any of the units rises unduly.

9.6 At the end of the 300-s (5 min) test period, stop the flow of water and when each unit has drained, wash down any fiber remaining on the walls of the vessel, using a plastic wash-bottle and directing the water jet in a direction opposite to the motion of the vessel. Then, stop the motor.

9.7 Unclamp the plastic vessels and remove each sieve disk in turn from its sieving unit, after ensuring that any fiber remaining in the conical depression in the sieve holder above has been washed down.

9.8 Carefully wash the fiber retained by the 203.2-mm (8 in.) diameter, 74- μ m (200 mesh) sieve onto a 63- μ m (230 mesh) sieve disk held in the fraction collector (or Büchner funnel) and apply a vacuum to speed the filtration. A venturi type water-jet suction pump may be used for this purpose. Connect the suction tube to the outlet of the fraction collector.

9.9 Dry the fiber fractions retained on their respective sieve disks to a constant weight of 105 to 110°C (220 to 230°F) by means of the drying apparatus.

9.10 After drying, cool the sieve disks and their fiber fractions for a minimum period of 0.9 ks (15 min) in a partly-closed container and immediately determine the mass to 0.005 g. Subtract the tare weight (previously determined) of each sieve disk from the gross weight of the corresponding fiber fraction and sieve disk.

10. Calculation or Interpretation of Results

10.1 A typical classification of a Grade 4 fiber, with calculation, is provided in the following example:

Screen	2.36 mm	1.18 mm	600 μ m	300 μ m	74 μ m	-74 μ m
Mass retained, g	0.080	0.460	0.500	0.180	0.270	...
-74 μ m (200 mesh) = 2.0 -	(0.80	+ 0.460	+ 0.500	+ 0.180	+ 0.270) =	0.510 g
Fraction mass, %	4.0	23.0	25.0	9.0	13.5	25.5
Cumulative mass, %	4.0	27.0	52.0	61.0	74.5	100.0

11. Report

11.1 Fully identify the sample stating the origin and the grade designation.

11.2 Report the average values of two acceptable tests and state the series of screens used.

11.3 If cumulative values have been calculated, report those also.

12. Precision and Bias

12.1 General Considerations:

12.1.1 If the corresponding individual percentages obtained for each screen fraction of the duplicate specimens differ by more than three units of percentage, test a third specimen. Average the results of two acceptable tests.

12.2 *Precision*—To obtain the desired precision observe the precautions in [Annex A1](#).

12.3 Repeatability:

12.3.1 The intralaboratory multiple-operator, single-apparatus repeatability is ± 0.1 g (2 s) obtained on any fraction, with Grade 4 fibers, as defined in [Practice E 177](#).

12.3.2 The equivalent repeatability for Grade 7D fibers is ± 0.1 g.

12.4 *Reproducibility*—Reproducibility has not yet been established in accordance with the requirements of ASTM.

12.5 *Bias*—In comparison with the results obtained by Test Method [D 2589](#) for results expressed as cumulative fractions

retained as a function of screen aperture on log-probability graph paper, no statistically significant bias has been obtained.

NOTE 5—At some laboratory locations, the use of stainless steel screen cloth has been found to give reproducible results over a longer period of time.

NOTE 6—In the case of crudy fibers, the classified fractions may be retained for examination and the percentage of crudy bundles and rock

particles determined by an approved method.

13. Keywords

13.1 asbestos; classification; length; length classification; T and N; Turner and Newall; wet length; wet length classification

ANNEXES

(Mandatory Information)

A1. PRECAUTIONS TO PROMOTE PRECISION AND PREVENT BIAS

A1.1 To obtain required precision and bias, the following general precautions should be observed.

A1.1.1 Determine that all the retained material has been washed from the walls of the vessels onto the corresponding screens and, having removed a given screen, wash any material in the cone beneath it into the vessel below.

A1.1.2 A water temperature of $21 \pm 10^{\circ}\text{C}$ ($70 \pm 20^{\circ}\text{F}$) is recommended.

A1.1.3 Run-in new screens by making at least ten trials, and preferably more, before they are put into regular use.

A1.1.4 Maintain stirrer clearance and strokes within the limits specified in [Annex A2](#).

A1.1.5 Check screens regularly (at least daily) for holes, slack or distorted cloth, and other visible damage. Also, check the effectiveness of the seal between individual screen disks and the rubber gaskets in their respective vessels at the beginning of each run. This is a routine precaution which is necessary to ensure that leakage of water does not occur.

A2. STIRRER ADJUSTMENTS

A2.1 Measurement of Stirrer Stroke

A2.1.1 Measure stroke by attaching a pencil to the side of the stirrer and measuring the chordal length of the arc swept on a piece of card held horizontally under it. Carefully mount the pencil in such a position that its point describes an arc having the same radius as that swept by the tip of the stirrer.

A2.2 Adjustment of Stirrer Stroke

A2.2.1 Stirrer stroke should be 60.3 to 63.5 mm (2.375 to 2.50 in.). If it is outside this range, adjust it as follows:

A2.2.1.1 Loosen the hexagonal nut of the driven crank mounted on the vertical stirrer shaft. Rotate the eccentric crank pin so that the pin moves inwards if the stroke is too small, or outwards if the stroke is too large. Tighten the locking nut and recheck the stroke. Repeat the procedure until the correct stroke is obtained.

A2.2.1.2 The arc swept by each of the four stirrers should stop 3 mm (0.125 in.) from the inner edge of the lower bevelled part of the plastic vessel.

A2.3 Stirrer Clearance

A2.3.1 The clearance between the tip of each stirrer and the screen over which it is mounted must be 1.5 to 2.4 mm (0.0625 to 0.09375 in.). If the clearance falls outside these limits, adjust it as follows:

A2.3.1.1 For the two upper stirrers, adjust the clearance by means of the small screw which is located on the stirrer support fork upon which the horizontal part of the stirrer arm rests.

A2.3.1.2 Adjust the two lower stirrers by loosening the socket screw which secures the stirrer fork to the stirrer drive shaft; adjust the height of the stirrer fork as necessary. Lowering the stirrer fork raises the stirrer tip and vice versa. The adjustment is made easier if feeler gages are inserted between the underside of the stirrer fork and the upper surface of the cam follower. Maintain the horizontal angular position of the stirrer fork during these adjustments, to ensure that the stirrer tip does not strike the side of the plastic vessel at the extremity of its stroke. Refer to limits imposed in [A2.2.1.2](#).

ASTM International takes no position respecting the validity of any patent rights asserted in connection with any item mentioned in this standard. Users of this standard are expressly advised that determination of the validity of any such patent rights, and the risk of infringement of such rights, are entirely their own responsibility.

This standard is subject to revision at any time by the responsible technical committee and must be reviewed every five years and if not revised, either reapproved or withdrawn. Your comments are invited either for revision of this standard or for additional standards and should be addressed to ASTM International Headquarters. Your comments will receive careful consideration at a meeting of the responsible technical committee, which you may attend. If you feel that your comments have not received a fair hearing you should make your views known to the ASTM Committee on Standards, at the address shown below.

This standard is copyrighted by ASTM International, 100 Barr Harbor Drive, PO Box C700, West Conshohocken, PA 19428-2959, United States. Individual reprints (single or multiple copies) of this standard may be obtained by contacting ASTM at the above address or at 610-832-9585 (phone), 610-832-9555 (fax), or service@astm.org (e-mail); or through the ASTM website (www.astm.org).