



Standard Test Method for Degradation of Fine Aggregate Due to Attrition¹

This standard is issued under the fixed designation C 1137; the number immediately following the designation indicates the year of original adoption or, in the case of revision, the year of last revision. A number in parentheses indicates the year of last reapproval. A superscript epsilon (ϵ) indicates an editorial change since the last revision or reapproval.

1. Scope*

1.1 This test method provides a procedure for indicating the relative degree to which a fine aggregate is likely to degrade due to the mixing and agitation of hydraulic cement concrete.

1.2 The values given in SI units are to be regarded as the standard. The values given in inch-pound units are for information only.

1.3 The text of this test method references notes and footnotes which provide explanatory material. These notes and footnotes (excluding those in tables and figures) shall not be considered as requirements of this test method.

1.4 *This standard does not purport to address all of the safety concerns, if any, associated with its use. It is the responsibility of the user of this standard to establish appropriate safety and health practices and determine the applicability of regulatory limitations prior to use.*

2. Referenced Documents

2.1 *ASTM Standards:*²

- C 33 Specification for Concrete Aggregates
- C 117 Test Method for Materials Finer Than 75- μ m (No. 200) Sieve in Mineral Aggregates by Washing
- C 125 Terminology Relating to Concrete and Concrete Aggregates
- C 136 Test Method for Sieve Analysis of Fine and Coarse Aggregates
- C 295 Guide for Petrographic Examination of Aggregates for Concrete
- C 670 Practice for Preparing Precision and Bias Statements for Test Methods for Construction Materials

C 702 Practice for Reducing Samples of Aggregate to Testing Size

D 75 Practice for Sampling Aggregates

E 11 Specification for Wire Cloth and Sieves for Testing Purposes

3. Summary of Test Method

3.1 A specimen of fine aggregate, of specified grading, is subjected to vigorous agitation under water from the action of a high-speed impeller. Degradation is measured by the decrease in fineness modulus (as defined in Terminology C 125) and the increase in amount of material finer than the 75- μ m (No. 200) sieve.

4. Significance and Use

4.1 The tendency of some fine aggregates, including those that comply with the requirements of Specification C 33, to degrade from the grinding action in a concrete mixer may affect mixing water demand, entrained air, and slump. When it is suspected that degradation during mixing is a problem, this test method may be useful for evaluating the extent of the problem.

4.2 This test method is of use for preliminary screening to indicate the need for further evaluation through petrographic examination (Guide C 295) or testing the quality of mortar, or concrete, or both made from the fine aggregate in question.

4.3 This test method is of use for comparing the results obtained with unknown materials against those with materials of known performance in concrete.

5. Apparatus

5.1 *Sieves*, conforming to Specification E 11: 75- μ m (No. 200), 150- μ m (No. 100), 300- μ m (No. 50), 600- μ m (No. 30), 1.18-mm (No. 16), 2.36-mm (No. 8), 4.75-mm (No. 4), and 9.5-mm (3/8-in.).

5.2 *Balance*—A balance or scale readable and accurate to 0.1 g or 0.1 % of the test specimen mass, whichever is greater, at any point within the range of use.

5.3 *Oven*—An oven of appropriate size capable of maintaining a uniform temperature of 110 ± 5 °C (230 ± 9 °F).

¹ This test method is under the jurisdiction of ASTM Committee C09 on Concrete and Concrete Aggregates and is the direct responsibility of Subcommittee C09.20 on Normal Weight Aggregates.

Current edition approved July 15, 2005. Published August 2005. Originally approved in 1990. Last previous edition approved in 1997 as C 1137 – 97.

² For referenced ASTM standards, visit the ASTM website, www.astm.org, or contact ASTM Customer Service at service@astm.org. For *Annual Book of ASTM Standards* volume information, refer to the standard's Document Summary page on the ASTM website.

*A Summary of Changes section appears at the end of this standard.

5.4 *Attrition Device*—A stainless steel octagonal tank, 140 mm (5½ in.) high and 110 mm (4½ in.) minimum inside width, with a motor-driven 19-mm (¾-in.) vertical shaft so mounted that it can be lowered into the desired position within the octagonal tank. Mounted on the shaft there shall be three horizontal sets of six pitched stainless steel blades³. A lid shall be provided with a hole for the shaft. See Figs. 1 and 2.

6.3 In preparing a test specimen, first remove material passing the 75-µm sieve by washing (in accordance with Test Method C 117), then oven dry and sieve (in accordance with Test Method C 136) into separate size fractions. Weigh and combine the fine aggregate size fractions to the selected grading.

6.4 If the test is to be performed on one of the standard

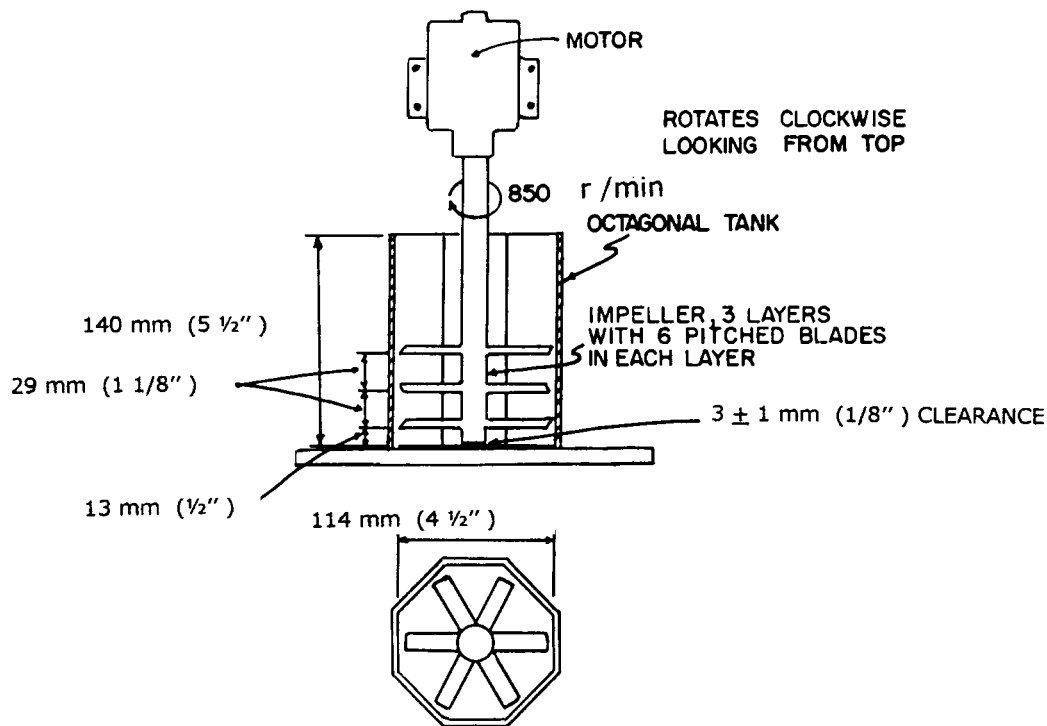

FIG. 1 Attrition Machine

5.5 *Rotating Device*—An electric motor-driven device or drill press suitable for driving the impeller clockwise as shown in Fig. 1. It shall be capable of driving the impeller at 850 ± 50 r/min with the specimen and water in the tank.

6. Sample Preparation

6.1 Sample the aggregate in accordance with Practice D 75 and reduce to test specimen size in accordance with Practice C 702.

6.2 Prepare a test specimen of 500 ± 5 g to a grading listed in Table 1. If these gradings are not practicable, it is permitted to use a grading not listed in Table 1 and compute the fineness modulus of this grading.

gradings from Table 1, use the grading nearest that of the as-received sample. Where different fine aggregates are to be compared, use the same initial grading for each.

7. Procedure

7.1 Determine the mass of the test specimen of oven-dry fine aggregate to the nearest 0.1 g and record.

7.2 Determine the mass of the cleaned, dry impeller. Insert the container and impeller in the drill press and adjust the vertical stop on the feed to position the bottom of the impeller shaft 3 ± 1 mm (1/8 ± 1/32 in.) above the bottom of the container. Make this adjustment prior to each test before introducing the specimen. Using a funnel, place the test specimen in the container. Brush any remaining material from the funnel into the container and add 175 g ± 5 g of water. Place the lid firmly on the container to avoid loss of the fine aggregate and the water. It is permitted, as an alternative method, to add the test specimen to the container and then insert the impeller by turning the shaft by hand until the impeller penetrates through the fine aggregate.

7.3 Run the attrition device for 6 ± 1/10 min at 850 ± 50 r/min.

³ The sole source of supply of the apparatus known to the committee at this time is Dorr-Oliver Eimco, 2850 South Decker Lake Drive, Salt Lake City, Utah, 84119, phone 801-526-2000, www.glv.com. An attrition tank with 100 mm attriting element (impeller) that can be used in a 850-r/min drill press or in a WEMCO laboratory flotation machine, parts No. 23828 (impeller), 23844 (tank), and 44519 (cover). If you are aware of alternative suppliers, please provide this information to ASTM International Headquarters. Your comments will receive careful consideration at a meeting of the responsible technical committee,¹ which you may attend.

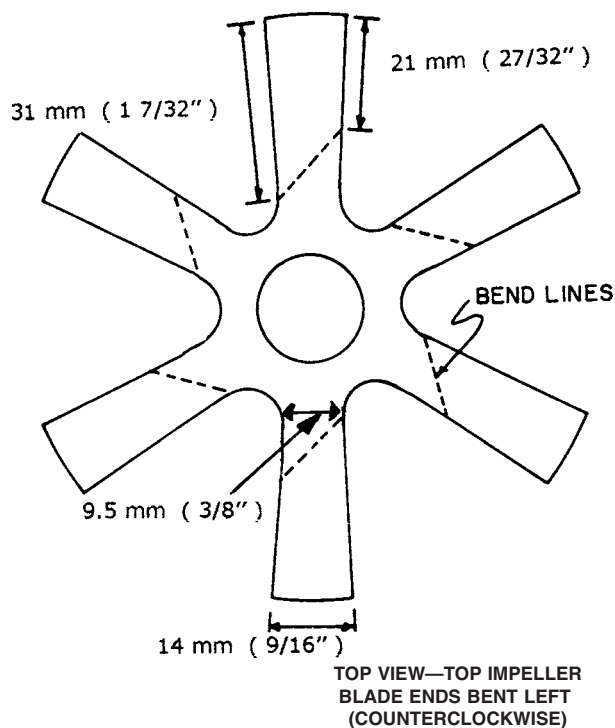

Impeller—102 mm (4 in.) diameter × 1.5 mm (No. 16 gage) thick; Three Layers Shaft—19 mm (3/4 in.) diameter extending 9.5 mm (3/8 in.) below bottom layer and the ends of the blades bent to 45° pitch. Blades on the top and bottom layer bent to the left (counterclockwise) and the middle layer bent to the right (clockwise).

FIG. 2 Impeller Details

TABLE 1 Alternative Test Gradings

Sieve Size	% Passing				
	No. 1	1A ^A	No. 2	No. 2A ^B	No. 3
4.75-mm (No. 4)	100	100	100	100	100
2.36-mm (No. 8)	80	100	88	100	100
1.18-mm (No. 16)	50	60	74	80	85
600-µm (No. 30)	25	30	49	50	60
300-µm (No. 50)	10	10	20	20	30
150-µm (No. 100)	2	0	5	0	10
75-µm (No. 200)	0	0	0	0	0
Fineness Modulus	3.33	3.00	2.64	2.50	2.15

^A Similar to No. 1 but with the fine and coarser fractions removed.

^B Similar to No. 2 but with the fine and coarser fractions removed.

7.4 Remove the container, lid, and impeller from the drill press and place in a pan. Using a minimum amount of water, wash the test specimen from the container, impeller, and lid into the pan. Avoid loss of any portion of the test specimen.

7.5 Test the whole test specimen in accordance with Test Method C 117 and test the washed material remaining in accordance with Test Method C 136.

7.6 Determine the mass of the clean, dry impeller after the test and record its mass to detect any long-term change in the impeller.

NOTE 1—Repeated testing will cause abrasive wear to the blades of the impeller. In a study of testing 100 specimens of siliceous fine aggregate, it was found that these specimens caused sufficient wear to the impeller to result in a 14 to 25 % reduction in the ability of the apparatus to cause degradation of the aggregate⁴. Degradation was measured by the increase in amount of material passing the 75-µm (No. 200) sieve. For this reason, it is good practice to monitor change in equipment efficiency by periodically testing replicate specimens of an aggregate of known behavior in the test. Such an aggregate can be established at the time the equipment is first used and a sufficient supply retained for monitoring purposes.

8. Report

8.1 Report the following data:

8.1.1 Grading as-received,

8.1.2 Grading as-tested (from Table 1 or as otherwise specified),

8.1.3 Grading after attrition,

8.1.4 Percent finer than the 75-µm (No. 200) sieve after attrition,

8.1.5 Fineness modulus before and after attrition, and

8.1.6 The mass of the clean, dry impeller before and after the test.

9. Precision and Bias

9.1 *Within Laboratory Precision*—In a study using one test apparatus, involving six different operators, testing six specimens of three materials of different attrition loss passing the 75-µm (No. 200) sieve, the following data on repeatability were obtained:

Mean % Loss Passing 75-µm (No. 200) Sieve, by Mass	Sample Standard Deviation, % by Mass ^A	Acceptable Range of Two Results, % by Mass ^A
5.5	0.31	0.88
9.9	0.26	0.74
29.1	0.47	1.33

^AThese numbers represent, respectively, the (1s%) and (d2s%) limits as described in Practice C 670.

9.2 *Multilaboratory Precision*—Data on multi-laboratory variation are not available.

9.3 *Bias*—The procedure in this test method has no bias because the values obtained for attrition loss can be defined only in terms of the test method.

10. Keywords

10.1 agitation; attrition; concrete; degradation; fine aggregates; mixing

⁴ Rogers, C. A., Bailey, M. L., Price, B., "Micro-Deval test for evaluating the quality of fine aggregate for concrete and asphalt," Transportation Research Board, Washington, D. C., Record 1301, pp. 68-76, 1991.

APPENDIX
(Nonmandatory Information)
X1. Interpretation of Results

X1.1 No specifications have been developed for results obtained with this test method. Davis et al.⁵ developed the attrition test to evaluate fine aggregate degradation that might occur during mixing. Meininger⁶ found that the amount of material that passed the 75- μm (No. 200) sieve might be a better indicator of fine aggregate behavior than change in fineness modulus. He found that sands that gave attrition losses [measured by material finer than 75- μm (No. 200)] greater than about 20 % were most likely to be susceptible to breakdown

during concrete mixing. He also noted that such sands might still be used satisfactorily in some cases. He also found that lesser problems might be experienced with sands giving losses above about 12 %.

It has been found⁴ that there is a moderate correlation between attrition loss of natural sands [material passing 75- μm (No. 200)] and the magnesium sulfate soundness loss of the sands. Crusher screenings and manufactured stone sands give considerably greater attrition losses than that obtained with natural sands of the same sulfate loss. This is due to breakage of the sharp and relatively brittle edges found in such angular products. It should be noted that for a given material, attrition loss of coarse graded sand [as measured by material passing 75- μm (No. 200)] is considerably greater than that of fine graded sand^{4,6}.

⁵ Davis, R. E., Mielenz, R. C., and Polivka, M., Importance of Petrographic Analysis and Special Tests not Usually Required in Judging Quality of Concrete Sand, Journal of Materials, ASTM, Vol. 2, No. 3, pp. 461-486, 1967.

⁶ Meininger, R. C., Aggregate Degradation During Mixing, National Ready Mixed Concrete Association, Technical Information Letter No. 341, Feb., 1978.

SUMMARY OF CHANGES

Committee C09 has identified the location of selected changes to this test method since the last issue, C 1137 – 97, that may impact the use of this specification. (Approved July 15, 2005)

(1) Revised Section 1.

(2) Updated Referenced Documents.

(3) Revised Sections 4-10.

(4) Added a within laboratory precision statement.

(5) Added an appendix to provide guidance on the interpretation of test results.

ASTM International takes no position respecting the validity of any patent rights asserted in connection with any item mentioned in this standard. Users of this standard are expressly advised that determination of the validity of any such patent rights, and the risk of infringement of such rights, are entirely their own responsibility.

This standard is subject to revision at any time by the responsible technical committee and must be reviewed every five years and if not revised, either reapproved or withdrawn. Your comments are invited either for revision of this standard or for additional standards and should be addressed to ASTM International Headquarters. Your comments will receive careful consideration at a meeting of the responsible technical committee, which you may attend. If you feel that your comments have not received a fair hearing you should make your views known to the ASTM Committee on Standards, at the address shown below.

This standard is copyrighted by ASTM International, 100 Barr Harbor Drive, PO Box C700, West Conshohocken, PA 19428-2959, United States. Individual reprints (single or multiple copies) of this standard may be obtained by contacting ASTM at the above address or at 610-832-9585 (phone), 610-832-9555 (fax), or service@astm.org (e-mail); or through the ASTM website (www.astm.org).