



# Standard Test Method for Abrasion Resistance of Concrete (Underwater Method)<sup>1</sup>

This standard is issued under the fixed designation C 1138M; the number immediately following the designation indicates the year of original adoption or, in the case of revision, the year of last revision. A number in parentheses indicates the year of last approval. A superscript epsilon ( $\epsilon$ ) indicates an editorial change since the last revision or reapproval.

## 1. Scope

1.1 This test method covers a procedure for determining the relative resistance of concrete (including concrete overlays and impregnated concrete) to abrasion under water (see **Note 1**). This procedure simulates the abrasive action of waterborne particles (silt, sand, gravel, and other solids).

**NOTE 1**—Other procedures are available for measuring abrasion resistance of concrete surfaces not under water. These include Test Methods **C 418**, **C 779**, and **C 944**.

1.2 The values stated in acceptable metric units are to be regarded as the standard.

1.3 *This standard does not purport to address all of the safety concerns, if any, associated with its use. It is the responsibility of the user of this standard to establish appropriate safety and health practices and determine the applicability of regulatory limitations prior to use. (Warning—Fresh hydraulic cementitious mixtures are caustic and may cause chemical burns to skin and tissue upon prolonged exposure.)*<sup>2</sup>

## 2. Referenced Documents

### 2.1 ASTM Standards:<sup>3</sup>

**C 42/C 42M** Test Method for Obtaining and Testing Drilled Cores and Sawed Beams of Concrete

**C 418** Test Method for Abrasion Resistance of Concrete by Sandblasting

**C 642** Test Method for Density, Absorption, and Voids in Hardened Concrete

**C 670** Practice for Preparing Precision and Bias Statements for Test Methods for Construction Materials

**C 779/C 779M** Test Method for Abrasion Resistance of Horizontal Concrete Surfaces

<sup>1</sup> This test method is under the jurisdiction of ASTM Committee C09 on Concrete and Concrete Aggregates and is the direct responsibility of Subcommittee C09.62 on Abrasion Testing.

Current edition approved Dec. 15, 2005. Published January 2006. Originally approved in 1989. Last previous edition approved in 1997 as C 1138 – 97.

<sup>2</sup> Section on Safety Precautions, *Manual of Aggregate and Concrete Testing, Annual Book of ASTM Standards*, Vol. 04.02.

<sup>3</sup> For referenced ASTM standards, visit the ASTM website, [www.astm.org](http://www.astm.org), or contact ASTM Customer Service at [service@astm.org](mailto:service@astm.org). For *Annual Book of ASTM Standards* volume information, refer to the standard's Document Summary page on the ASTM website.

**C 944** Test Method for Abrasion Resistance of Concrete or Mortar Surfaces by the Rotating-Cutter Method

**E 18** Test Methods for Rockwell Hardness and Rockwell Superficial Hardness of Metallic Materials

## 3. Significance and Use

3.1 This test method is intended to qualitatively simulate the behavior of swirling water containing suspended and transported solid objects that produce abrasion of concrete and cause potholes and related effects.

3.2 This test method should provide a relative evaluation of the resistance of concrete to such action.

3.3 The results are expected to be useful in selection of materials, mixtures, and construction practices for use where such action is to be expected.

3.4 The test method is not intended to provide a quantitative measurement of the length of service that may be expected from a specific concrete.

## 4. Apparatus

4.1 *Rotating Device*—A drill press or similar device with a chuck capable of holding and rotating the agitation paddle under test conditions at a speed of  $1200 \pm 100$  rpm shall be used.

4.2 *Test Container*—A steel pipe,  $305 \pm 6$ -mm ( $12 \pm 1/4$ -in.) inside diameter by  $450 \pm 25$ -mm ( $18 \pm 1$ -in.) high, fitted with a watertight steel base shall be used (see **Fig. 1**).

4.3 *Agitation Paddle*—The agitation paddle shall be as shown in **Fig. 2**.

4.4 *Abrasive Charges*—Seventy grade 1000 chrome steel grinding balls with nominal sizes as specified in **Table 1** shall be used. The steel of which the balls are made shall have a Rockwell C-scale hardness of  $65 \pm 5$  as determined by Test Methods **E 18**. The balls shall have a smooth texture and no apparent mold seam (see **Note 2**).

**NOTE 2**—An abrasive charge meeting the requirements of **Table 1** will have a mass of approximately 1530 to 1900 g (3.8 to 4.2 lb). When the mass of the charge approaches the lower limit, replace the undersize or underweight balls not complying with **Table 1**.

4.5 *Scales*—A platform scale having a capacity of at least 45 kg (100 lb) or more and accurate to within at least 5.0 g (0.01 lb) at any point within the range used in this test shall be

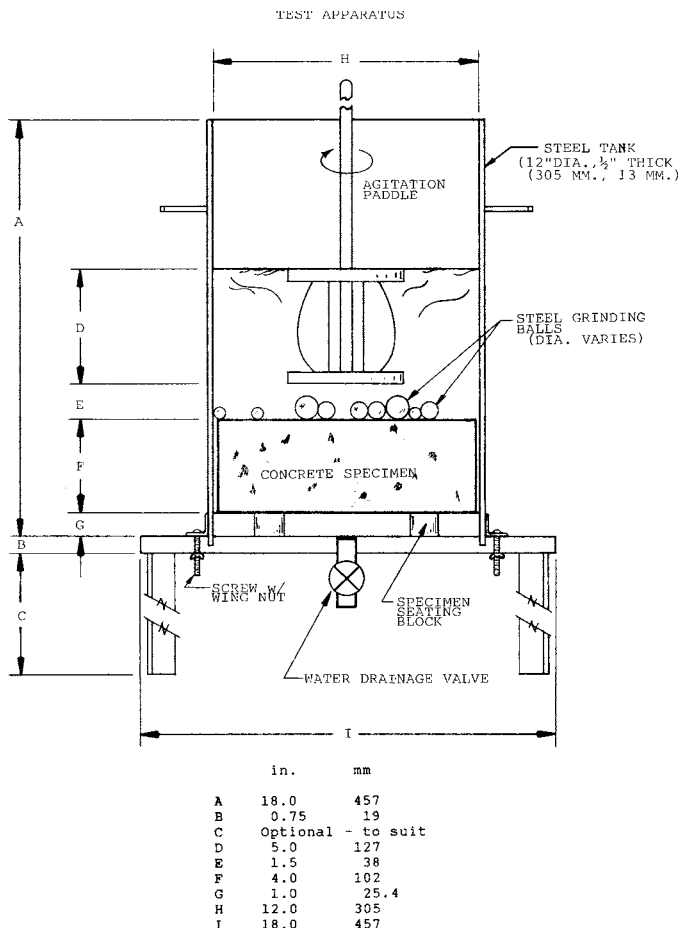

FIG. 1 Test Apparatus

used. The scale shall be equipped with a suitable apparatus for suspending the sample in its container in water from the center of the weighing platform.

4.6 *Weighing Basket*—A wire basket or other suitable support shall be provided for weighing the specimen in water. The weighing basket shall be constructed to prevent entrapping air when it and the specimen are submerged.

4.7 *Water Tank*—A suitable watertight tank into which the basket and the specimen can be suspended below the scale shall be furnished.

4.8 *Seating Block*—A minimum of three steel blocks 25 by 25 by 25 mm (1 by 1 by 1 in.) shall be used to support the specimen.

### 5. Test Specimens

5.1 The test specimen shall be cylindrical in shape, having a diameter approximately 6-mm (1/4-in.) less than that of the inside diameter of the test container and a height of 100 ± 13 mm (4 ± 1/2 in.). It may be molded from freshly mixed concrete or cored from hardened concrete (see Note 3). Cores shall be taken in accordance with Methods C 42.

NOTE 3—Specimens should be tested at an age appropriate for the material being evaluated. Most testing done to date has been done at 28 days. Concretes containing pozzolans should be tested at an age that allows development of appropriate strength. Toppings and impregnated concretes should be tested at an age appropriate for the material and in

compliance with the manufacturer’s recommendations. The appropriate testing age may also depend upon when the concrete will be put into service.

5.2 If the specimen has a membrane curing compound on the surface, remove it completely by steel wire brushing prior to the soaking period.

5.3 Soak the specimen in lime-saturated water or in the water to which the concrete shall be subjected in service for a minimum of 48 h prior to testing.

5.4 Determine the average diameter of the top surface of the specimen to be tested to the nearest 2 mm (1/16 in.) by averaging two diameters measured at right angles to each other. This average diameter shall be used in calculating the top surface area.

5.5 Surface dry the specimen. Determine and record the mass in air to the nearest 25.0 g (0.05 lb). Determine and record the apparent mass of the specimen immersed in water to the nearest 25.0 g (0.05 lb). The procedure of Test Method C 642 shall be followed using water at 23 ± 1.7 °C (73.4 ± 3 °F) having a density of 997 ± 2 kg/m<sup>3</sup>. Remove all entrapped air by shaking the specimen while it is immersed in the water for weighing.

### 6. Procedure

6.1 Place the specimen in the test container with the surface to be tested facing up and the seating blocks in place.

6.2 Position the specimen so that its surface is normal to the drill shaft and the center of the specimen coincides with the drill shaft.

6.3 Mount the agitation paddle in the drill press. The bottom of the agitation paddle shall be 38 ± 5 mm (1 1/2 ± 1/4 in.) above the surface of the specimen.

6.4 Determine and record the mass of the abrasive charge to the nearest 10 g (0.02 lb). Place it on the surface of the specimen and add water of the same type as used in the saturation period to 165 ± 5 mm (6 1/2 ± 1/4 in.) above the surface of the specimen.

6.5 Start the paddle rotating and check that the paddle is rotating at the required speed with the paddle immersed.

6.6 Remove the specimen from the test container at the end of every 12 h of operation. Flush off the abraded material and surface dry. Determine and record the mass of the specimen in air and in water.

6.7 The standard test shall consist of six 12-h periods for a total of 72 h (see Note 4).

NOTE 4—Testing totalling 24 h generally produces significant abrasion in most concrete surfaces, but it is recommended to extend the period of simulation if more severe abrasion is desired. Additional testing time may be required for concrete that is highly resistant to abrasion.

### 7. Calculation

7.1 Calculate the abrasion loss as follows:

7.1.1 Calculate the volume of the specimen at any time as follows:

$$V_t = \frac{W_{air} - W_{water}}{G_w} \quad (1)$$

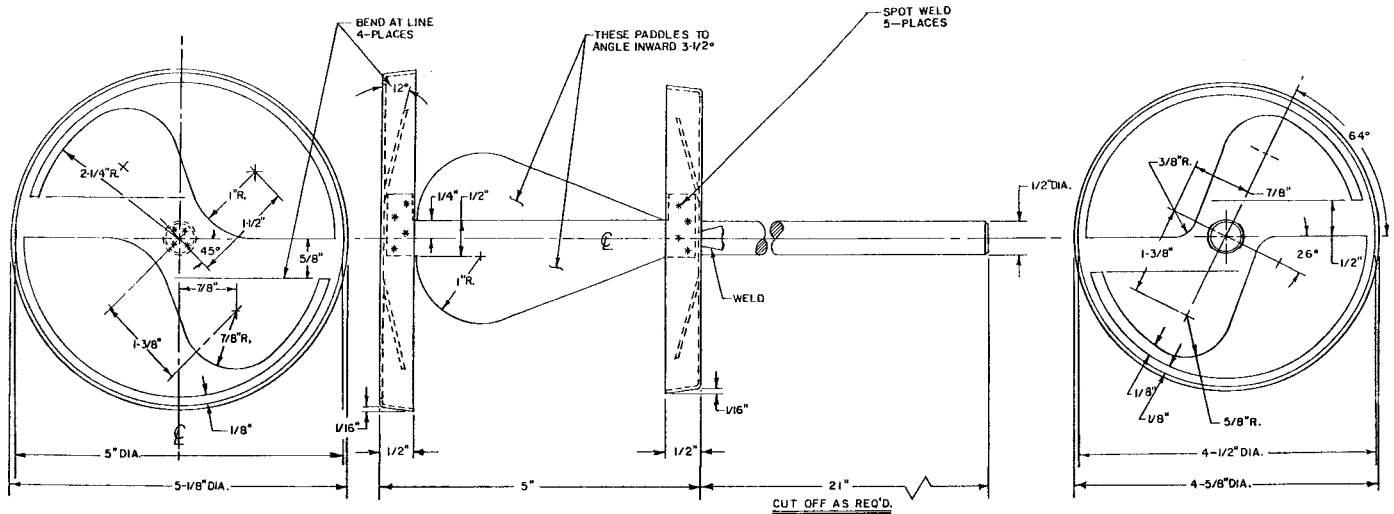

NOTE 1—1—16 Ga (0.059 in.)—304 Stainless Steel  
 NOTE 2—Rotation of agitation paddle clockwise when viewed from shaft end.  
 NOTE 3—Shaft length to be adjusted to fit assembly in Fig. 11.

in.	mm
21	533
5 1/8	130
5	127
4 5/8	117
4 1/2	114
3 3/16	97
2 1/4	57
1 1/2	38
1 3/8	35
1	25
7/8	22
5/8	16
1/2	13
3/8	10
1/4	6
1/8	3
1/16	2

TOLERANCE UNLESS OTHERWISE SPECIFIED	Material 16 GA.(.059) STEEL	FINISH	TITLE
	REVISIONS	BY	DATE
			AGITATION PADDLE

FIG. 2 Agitation Paddle

TABLE 1 Abrasive Charges

Number of Balls	Nominal Size	Minimum Diameter
10	1.00 in.	25.3 mm (0.95 in.)
35	0.75 in.	19.0 mm (0.70 in.)
25	0.50 in.	12.6 mm (0.45 in.)

where:

- $V_t$  = volume of the specimen at the desired time,  $m^3$ ,
- $W_{air}$  = mass of the specimen in air at the desired time, kg,
- $W_{water}$  = apparent mass of the specimen in water at the desired time, kg, and
- $G_w$  = unit weight of water  $kg/m^3$ .

7.1.2 Calculate the volume of concrete lost at the end of any time increment of testing as follows:

$$VL_t = V_i - V_t \quad (2)$$

where:

- $VL_t$  = volume of material lost by abrasion at the end of the test increment in question,  $m^3$ ,
- $V_i$  = volume of specimen before testing,  $m^3$ , and
- $V_t$  = volume of the specimen at the end of the test increment in question  $m^3$ .

7.2 Should it be desired to calculate the average depth of wear at the end of any time increment of testing based on volume of abraded material, it may be done as follows:

$$ADA_t = VL_t/A \quad (3)$$

where:

- $ADA_t$  = average depth of abrasion at the end of the test increment in question, m, and
- $A$  = area of top of specimen  $m^2$ .

## 8. Report

8.1 The report shall include the following:

8.1.1 A plot of time versus abrasion loss of at least three individual test specimens and the average of all specimens of a type that were tested.

8.1.2 The average diameter of each specimen. The volume of each specimen at the end of each test period.

8.1.3 Relevant data as desired on the concrete represented by the specimens.

8.1.4 Mass of the grinding balls at the beginning and end of the testing.

## 9. Precision and Bias

9.1 *Precision*—The single laboratory coefficient of variation among test specimens made from a single batch of concrete

was found to be 14.0 %. Therefore, in a properly conducted test, the range among test results from the three specimens required by the test method should be no greater than 46.2 % of their mean. (See **Note 5**.)<sup>4</sup>

**NOTE 5**—This number represents the 1 S limit, as defined by Practice **C 670**. This limit was calculated according to paragraph 3.3.2 of Practice **C 670**–91a. The variation due to making specimens from different concrete batches was found to be too small to detect.

9.2 *Bias*—No estimate of bias is being made because there is no recognized standard material for this test method.

<sup>4</sup> Supporting data have been filed at ASTM International Headquarters and may be obtained by requesting Research Report RR: C09-1009.

## APPENDIX

### (Nonmandatory Information)

#### X1. PRECISION OF THE TEST METHOD

X1.1 This test method was originally developed and used by the Corps of Engineers.<sup>5</sup> When developed and during its initial use, abrasion loss as determined by the test method was expressed as a percentage of the original mass of the specimen. For tests so conducted the single-operator standard deviation (1S) was found to be 0.42 % and hence, the results of two

properly conducted tests by the same operator on specimens from the same batch of concrete should not differ by more than 1.18 % (D2S). These limits were calculated as described in Practice **C 670**.

X1.2 The test method was revised to reflect loss in terms of volume rather than in terms of mass to eliminate differences in results resulting from the allowable variations in specimen size.

<sup>5</sup> Liu, Tony C., "Abrasion Resistance of Concrete," *ACI Journal, Proceedings* Vol 78, No. 5, Sept.-Oct. 1981, pp 341-350.

*ASTM International takes no position respecting the validity of any patent rights asserted in connection with any item mentioned in this standard. Users of this standard are expressly advised that determination of the validity of any such patent rights, and the risk of infringement of such rights, are entirely their own responsibility.*

*This standard is subject to revision at any time by the responsible technical committee and must be reviewed every five years and if not revised, either reapproved or withdrawn. Your comments are invited either for revision of this standard or for additional standards and should be addressed to ASTM International Headquarters. Your comments will receive careful consideration at a meeting of the responsible technical committee, which you may attend. If you feel that your comments have not received a fair hearing you should make your views known to the ASTM Committee on Standards, at the address shown below.*

*This standard is copyrighted by ASTM International, 100 Barr Harbor Drive, PO Box C700, West Conshohocken, PA 19428-2959, United States. Individual reprints (single or multiple copies) of this standard may be obtained by contacting ASTM at the above address or at 610-832-9585 (phone), 610-832-9555 (fax), or service@astm.org (e-mail); or through the ASTM website (www.astm.org).*