



Standard Test Method for Electrical Indication of Concrete's Ability to Resist Chloride Ion Penetration¹

This standard is issued under the fixed designation C 1202; the number immediately following the designation indicates the year of original adoption or, in the case of revision, the year of last revision. A number in parentheses indicates the year of last reapproval. A superscript epsilon (ϵ) indicates an editorial change since the last revision or reapproval.

1. Scope*

1.1 This test method covers the determination of the electrical conductance of concrete to provide a rapid indication of its resistance to the penetration of chloride ions. This test method is applicable to types of concrete where correlations have been established between this test procedure and long-term chloride ponding procedures such as those described in AASHTO T 259. Examples of such correlations are discussed in Refs 1-5.²

1.2 The values stated in inch-pound units are to be regarded as the standard, except where SI units are given first followed by inch-pound units in parentheses. The values given in parentheses are for information only.

1.3 *This standard does not purport to address all of the safety concerns, if any, associated with its use. It is the responsibility of the user of this standard to establish appropriate safety and health practices and determine the applicability of regulatory limitations prior to use.*

2. Referenced Documents

2.1 ASTM Standards:³

- C 42/C 42M Test Method for Obtaining and Testing Drilled Cores and Sawed Beams of Concrete
- C 192/C 192M Practice for Making and Curing Concrete Test Specimens in the Laboratory
- C 670 Practice for Preparing Precision and Bias Statements for Test Methods for Construction Materials

2.2 AASHTO Standard:

- T 259 Method of Test for Resistance of Concrete to Chloride Ion Penetration⁴

¹ This test method is under the jurisdiction of ASTM Committee C09 on Concrete and Concrete Aggregates and is the direct responsibility of Subcommittee C09.66 on Concrete's Resistance to Fluid Penetration.

Current edition approved Dec. 15, 2008. Published January 2009. Originally approved in 1991. Last previous edition approved in 2007 as C 1202 – 07.

² The boldface numbers in parentheses refer to the list of references at the end of this standard.

³ For referenced ASTM standards, visit the ASTM website, www.astm.org, or contact ASTM Customer Service at service@astm.org. For *Annual Book of ASTM Standards* volume information, refer to the standard's Document Summary page on the ASTM website.

⁴ Methods of Sampling and Testing, 1986, American Association of State Highway and Transportation Officials, 444 N. Capitol St., NW, Washington, DC 20001.

3. Summary of Test Method

3.1 This test method consists of monitoring the amount of electrical current passed through 2-in. (51-mm) thick slices of 4-in. (102-mm) nominal diameter cores or cylinders during a 6-h period. A potential difference of 60 V dc is maintained across the ends of the specimen, one of which is immersed in a sodium chloride solution, the other in a sodium hydroxide solution. The total charge passed, in coulombs, has been found to be related to the resistance of the specimen to chloride ion penetration.

4. Significance and Use

4.1 This test method covers the laboratory evaluation of the electrical conductance of concrete samples to provide a rapid indication of their resistance to chloride ion penetration. In most cases the electrical conductance results have shown good correlation with chloride ponding tests, such as AASHTO T 259, on companion slabs cast from the same concrete mixtures (Refs 1-5).

4.2 This test method is suitable for evaluation of materials and material proportions for design purposes and research and development.

4.3 Sample age has significant effects on the test results, depending on the type of concrete and the curing procedure. Most concretes, if properly cured, become progressively and significantly less permeable with time.

4.4 This test method was developed originally for evaluations of alternative materials, but in practice its use has evolved to applications such as quality control and acceptance testing. In such cases it is imperative that the curing procedures and the age at time of testing be clearly defined.

4.5 Table 1 provides a qualitative relationship between the results of this test and the chloride ion penetrability of concrete.

4.6 Care should be taken in interpreting results of this test when it is used on surface-treated concretes, for example, concretes treated with penetrating sealers. The results from this test on some such concretes indicate low resistance to chloride ion penetration, while 90-day chloride ponding tests on companion slabs show a higher resistance.

*A Summary of Changes section appears at the end of this standard.

TABLE 1 Chloride Ion Penetrability Based on Charge Passed (1)

Charge Passed (coulombs)	Chloride Ion Penetrability
>4,000	High
2,000-4,000	Moderate
1,000-2,000	Low
100-1,000	Very Low
<100	Negligible

4.7 The details of the test method apply to 4-in. (102-mm) nominal diameter specimens. This includes specimens with actual diameters ranging from 3.75 in. (95 mm) to 4.0 in. (102 mm). Other specimen diameters may be tested with appropriate changes in the applied voltage cell design (see 7.5 and Fig. 1).

4.7.1 For specimen diameters other than 3.75 in. (95 mm), the test result value for total charge passed must be adjusted following the procedure in 11.2. For specimens with diameters less than 3.75 in. (95 mm), particular care must be taken in coating and mounting the specimens to ensure that the conductive solutions are able to contact the entire end areas during the test.

5. Interferences

5.1 This test method can produce misleading results when calcium nitrite has been admixed into a concrete. The results from this test on some such concretes indicate higher coulomb values, that is, lower resistance to chloride ion penetration, than from tests on identical concrete mixtures (controls) without calcium nitrite. However, long-term chloride ponding tests indicate the concretes with calcium nitrite were at least as resistant to chloride ion penetration as the control mixtures.

NOTE 1—Other admixtures might affect results of this test similarly. Long term ponding tests are recommended if an admixture effect is suspected.

5.2 Since the test results are a function of the electrical resistance of the specimen, the presence of reinforcing steel or other embedded electrically conductive materials may have a significant effect. The test is not valid for specimens containing reinforcing steel positioned longitudinally, that is, providing a continuous electrical path between the two ends of the specimen.

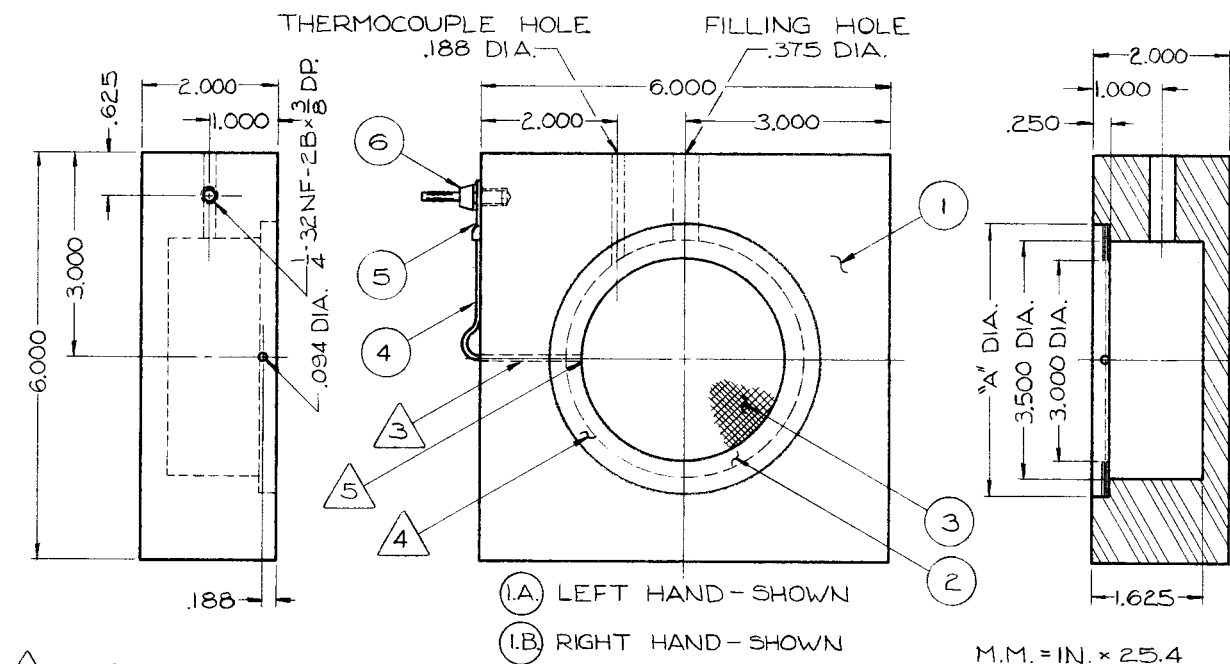

NOTES:

- 1.) DIAMETER "A" SHOULD BE $\frac{1}{8}$ " LARGER THAN OUTSIDE DIA. OF SPECIMEN.
- 2.) NOT TO SCALE.
- 3.) SEAL WIRE IN HOLE WITH SILICONE RUBBER CAULK.
- 4.) SCREEN SOLDERED BETWEEN SHIMS.
- 5.) SOLDER WIRE TO BRASS SHIM.
- 6.) POLYMETHYLMETHACRYLATE, e.g., PLEXIGLAS.

ITEM	QTY.	NOMENCLATURE	SPECIFICATION
6	2	BANANA PLUG	$\frac{1}{4}$ MALE, INSULATED
5	2	TERMINAL	12-10- $\frac{1}{4}$
4	2	WIRE, COPPER	#14, SOLID NYLCLAD
3	2	SCREEN, BRASS	#20 MESH, "A" DIA.
2	4	SHIM, BRASS	0.02 THK.
I.B. I.A.	1 1	CELL BLOCK END	PMMA SHEET

FIG. 1 Applied Voltage Cell (construction drawing)

6. Apparatus

6.1 *Vacuum Saturation Apparatus* (see Fig. 2 for example):
 6.1.1 *Separatory Funnel*, or other sealable, bottom-draining container with a minimum capacity of 500 mL.

6.1.2 *Beaker (1000 mL or larger) or other container*—Capable of holding concrete specimen(s) and water and of fitting into vacuum desiccator (see 6.1.3).

6.1.3 *Vacuum Desiccator*—250-mm (9.8-in.) inside diameter or larger. Desiccator must allow two hose connections through a rubber stopper and sleeve or through a rubber stopper only. Each connection must be equipped with a stopcock.

6.1.4 *Vacuum Pump or Aspirator*—Capable of maintaining a pressure of less than 50 mm Hg (6650 Pa) in desiccator.

NOTE 2—Since vacuum will be drawn over water, a vacuum pump should be protected with a water trap, or pump oil should be changed after each operation.

6.1.5 *Vacuum Gage or Manometer*—Accurate to ± 5 mm Hg (± 665 Pa) over range 0–100 mm Hg (0–13300 Pa) pressure.

6.2 *Coating Apparatus and Materials:*

6.2.1 *Coating*—Rapid setting, electrically nonconductive, capable of sealing side surface of concrete cores.

6.2.2 *Balance or Scale, Paper Cups, Wooden Spatulas, and Disposable Brushes*—For mixing and applying coating.

6.3 *Specimen Sizing Equipment* (not required if samples are cast to final specimen size).

6.3.1 *Movable Bed Water-Cooled Diamond Saw or Silicon Carbide Saw*.

7. Reagents, Materials, and Test Cell

7.1 *Specimen-Cell Sealant*—Capable of sealing concrete to poly (methyl methacrylate), for example, Plexiglas, against water and dilute sodium hydroxide and sodium chloride solutions at temperatures up to 200 °F (90 °C); examples include RTV silicone rubbers, silicone rubber caulking, other synthetic rubber sealants, silicone greases, and rubber gaskets.

7.2 *Sodium Chloride Solution*—3.0 % by mass (reagent grade) in distilled water.

7.3 *Sodium Hydroxide Solution*—0.3 N (reagent grade) in distilled water.

7.3.1 **Warning**—Before using NaOH, review: (1) the safety precautions for using NaOH; (2) first aid for burns; and (3) the emergency response to spills, as described in the manufacturer’s Material Safety Data Sheet or other reliable safety literature. NaOH can cause very severe burns and injury to unprotected skin and eyes. Suitable personal protective equipment should always be used. These should include full-face shields, rubber aprons, and gloves impervious to NaOH. Gloves should be checked periodically for pin holes.

7.4 *Filter Papers*—No. 2, 90-mm (3.5-in.) diameter (not required if rubber gasket is used for sealant (see 7.1) or if sealant can be applied without overflowing from shim onto mesh).

7.5 *Applied Voltage Cell* (see Fig. 1 and Fig. 3)—Two symmetric poly (methyl methacrylate) chambers, each containing electrically conductive mesh and external connectors. One design in common use is shown in Fig. 1 and Fig. 3. However, other designs are acceptable, provided that overall dimensions (including dimensions of the fluid reservoir) are the same as shown in Fig. 1 and width of the screen and shims are as shown.

7.6 *Temperature Measuring Device (optional)*—30 to 250 °F (0 to 120 °C) range.

7.7 *Voltage Application and Data Readout Apparatus*—Capable of holding 60 ± 0.1 V dc across applied voltage cell over entire range of currents and of displaying voltage accurate to ± 0.1 V and current to ± 1 mA. Apparatus listed in 7.7.1-7.7.5 is a possible system meeting this requirement.

7.7.1 *Voltmeter*—Digital (DVM), 3 digit, minimum 0–99.9 V range, rated accuracy ± 0.1 %.

7.7.2 *Voltmeter*—Digital (DVM), 4½ digit, 0–200 mV range, rated accuracy ± 0.1 %.

7.7.3 *Shunt Resistor*—100 mV, 10A rating, tolerance ± 0.1 %. Alternatively, a 0.01 Ω resistor, tolerance ± 0.1 %, may be used, but care must be taken to establish very low resistance connections.

7.7.4 *Constant Voltage Power Supply*—0–80 V dc, 0–2 A, capable of holding voltage constant at 60 ± 0.1 V over entire range of currents.

7.7.5 *Cable*—Two conductor, No. 14 (1.6 mm), insulated, 600 V.

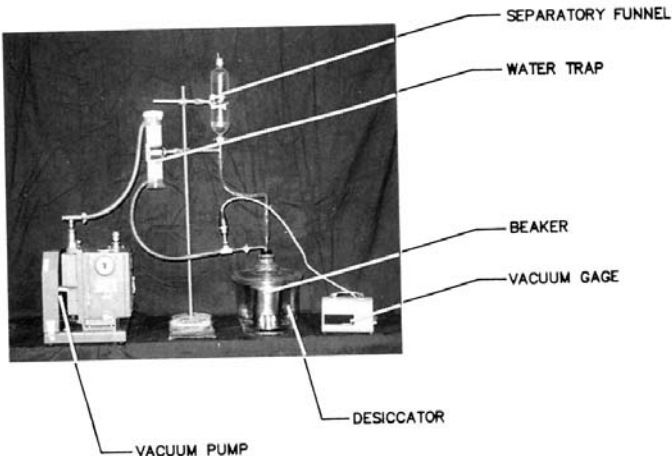

FIG. 2 Vacuum Saturation Apparatus

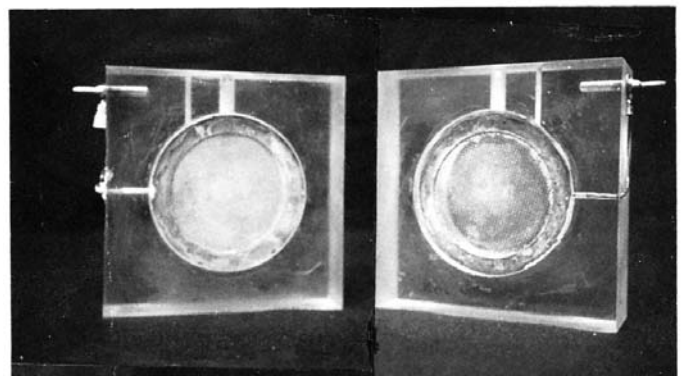

FIG. 3 Applied Voltage Cell-Face View

8. Test Specimens

8.1 Sample preparation and selection depends on the purpose of the test. For evaluation of materials or their proportions, samples may be (a) cores from test slabs or from large diameter cylinders or (b) 4-in. (102-mm) diameter cast cylinders. For evaluation of structures, samples may be (a) cores from the structure or (b) 4-in. (102-mm) diameter cylinders cast and cured at the field site. Coring shall be done with a drilling rig equipped with a 4-in. (102-mm) diameter diamond-dressed core bit. Select and core samples following procedures in Test Method C 42/C 42M. Cylinders cast in the laboratory shall be prepared following procedures in Practice C 192/C 192M. When cylinders are cast in the field to evaluate a structure, care must be taken that the cylinders receive the same treatment as the structure, for example, similar degree of consolidation, curing, and temperature history during curing.

NOTE 3—The maximum allowable aggregate size has not been established for this test. Users have indicated that test repeatability is satisfactory on specimens from the same concrete batch for aggregates up to 25.0 mm (1 in.) nominal maximum size.

8.2 Transport the cores or field-cured cylinders to the laboratory in sealed (tied) plastic bags. If specimens must be shipped, they should be packed so as to be properly protected from freezing and from damage in transit or storage.

8.3 Using the water-cooled diamond saw or silicon carbide saw, cut a $2 \pm \frac{1}{8}$ in. (51 ± 3 mm) slice from the top of the core or cylinder, with the cut parallel to the top of the core. This slice will be the test specimen. Use a belt sander to remove any burrs on the end of the specimen.

8.4 Special processing is necessary for core samples where the surface has been modified, for example, by texturing or by applying curing compounds, sealers, or other surface treatments, and where the intent of the test is not to include the effect of the modifications. In those cases, the modified portion of the core shall be removed and the adjacent $2 \pm \frac{1}{8}$ in. (51 ± 3 mm) slice shall be used for the test.

9. Conditioning

9.1 Vigorously boil a litre or more of tapwater in a large sealable container. Remove container from heat, cap tightly, and allow water to cool to ambient temperature.

9.2 Allow specimen prepared in Section 8 to surface dry in air for at least 1 h. Prepare approximately $\frac{1}{2}$ oz (10 g) of rapid setting coating and brush onto the side surface of specimen. Place the sample on a suitable support while coating to ensure complete coating of sides. Allow coating to cure according to the manufacturer's instructions.

9.3 The coating should be allowed to cure until it is no longer sticky to the touch. Fill any apparent holes in the coating and allow additional curing time, as necessary. Place specimen in beaker or other container (see 6.1.2), then place container in vacuum desiccator. Alternatively, place specimen directly in vacuum desiccator. Both end faces of specimen must be exposed. Seal desiccator and start vacuum pump or aspirator. Pressure should decrease to less than 50 mm Hg (6650 Pa) within a few minutes. Maintain vacuum for 3 h.

9.4 Fill separatory funnel or other container (see 6.1.1) with the de-aerated water prepared in 9.1. With vacuum pump still

running, open water stopcock and drain sufficient water into beaker or container to cover specimen (do not allow air to enter desiccator through this stopcock).

9.5 Close water stopcock and allow vacuum pump to run for one additional hour.

9.6 Close vacuum line stopcock, then turn off pump. (Change pump oil if a water trap is not being used.) Turn vacuum line stopcock to allow air to re-enter desiccator.

9.7 Soak specimen under water (the water used in steps 9.4-9.6) in the beaker for 18 ± 2 h.

10. Procedure

10.1 Remove specimen from water, blot off excess water, and transfer specimen to a sealed can or other container which will maintain the specimen in 95 % or higher relative humidity.

10.2 Specimen mounting (all sealants other than rubber gaskets; use 10.2.2 or 10.2.3, as appropriate):

10.2.1 If using two-part specimen-cell sealant, prepare approximately 0.7 to 1.4 oz (20 to 40 g).

10.2.2 *Low Viscosity Specimen-Cell Sealant*—If filter paper is necessary, center filter paper over one screen of the applied voltage cell. Trowel sealant over brass shims adjacent to applied voltage cell body. Carefully remove filter paper. Press specimen onto screen; remove or smooth excess sealant which has flowed out of specimen-cell boundary.

10.2.3 *High Viscosity Specimen-Cell Sealant*—Set specimen onto screen. Apply sealant around specimen-cell boundary.

10.2.4 Cover exposed face of specimen with an impermeable material such as rubber or plastic sheeting. Place rubber stopper in cell filling hole to restrict moisture movement. Allow sealant to cure per manufacturer's instructions.

10.2.5 Repeat steps 10.2.2 (or 10.2.3) and 10.2.4 on second half of cell. (Specimen in applied voltage cell now appears as shown in Fig. 4.)

10.3 Specimen mounting (rubber gasket alternative): Place a 4-in. outside diameter by 3-in. inside diameter by $\frac{1}{4}$ -in. (100 mm outside diameter by 75 mm inside diameter by 6 mm) circular vulcanized rubber gasket in each half of the test cell. Insert sample and clamp the two halves of the test cell together to seal.

10.4 Fill the side of the cell containing the top surface of the specimen with 3.0 % NaCl solution. (That side of the cell will



FIG. 4 Specimen Ready for Test

be connected to the negative terminal of the power supply in 10.5.) Fill the other side of the cell (which will be connected to the positive terminal of the power supply) with 0.3 N NaOH solution.

10.5 Attach lead wires to cell banana posts. Make electrical connections to voltage application and data readout apparatus as appropriate; for example, for system listed in 7.7.1-7.7.5, connect as shown in Fig. 5. Turn power supply on, set to 60.0 ± 0.1 V, and record initial current reading. Temperatures of the specimen, applied voltage cell, and solutions shall be 68 to 77 °F (20 to 25 °C) at the time the test is initiated, that is, when the power supply is turned on.

10.6 During the test, the air temperature around the specimens shall be maintained in the range of 68 to 77 °F (20 to 25 °C).

10.7 Read and record current at least every 30 min. If a voltmeter is being used in combination with a shunt resistor for the current reading (see Fig. 5), use appropriate scale factors to convert voltage reading to amperes. Each half of the test cell must remain filled with the appropriate solution for the entire period of the test.

NOTE 4—During the test, the temperature of the solutions should not be allowed to exceed 190 °F (90 °C) in order to avoid damage to the cell and to avoid boiling off the solutions. Although it is not a requirement of the method, the temperature of the solutions can be monitored with thermocouples installed through the 1/8-in. (3-mm) venthole in the top of the cell. High temperatures occur only for highly penetrable concretes. If a test of a 2-in. (51-mm) thick specimen is terminated because of high temperatures, this should be noted in the report, along with the time of termination, and the concrete rated as having very high chloride ion penetrability (see 12.1.9).

10.8 Terminate test after 6 h, except as discussed in Note 4.

10.9 Remove specimen. Rinse cell thoroughly in tapwater; strip out and discard residual sealant.

11. Calculation and Interpretation of Results

11.1 Plot current (in amperes) versus time (in seconds). Draw a smooth curve through the data, and integrate the area underneath the curve in order to obtain the ampere-seconds, or coulombs, of charge passed during the 6-h test period. (See Note 5) Alternatively, use automatic data processing equipment to perform the integration during or after the test and to display

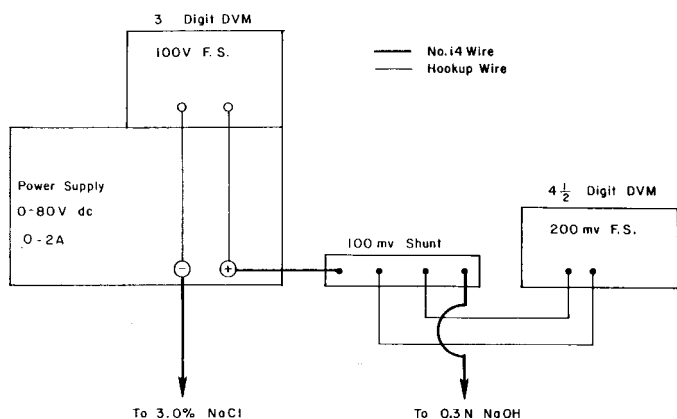

FIG. 5 Electrical Block Diagram (example)

the coulomb value. The total charge passed is a measure of the electrical conductance of the concrete during the period of the test.

NOTE 5—Sample Calculation—If the current is recorded at 30 min intervals, the following formula, based on the trapezoidal rule, can be used with an electronic calculator to perform the integration:

$$Q = 900 (I_0 + 2I_{30} + 2I_{60} + \dots + 2I_{300} + 2I_{330} + I_{360}) \quad (1)$$

where:

Q = charge passed (coulombs),

I_0 = current (amperes) immediately after voltage is applied, and

I_t = current (amperes) at t min after voltage is applied.

11.2 If the specimen diameter is other than 3.75 in. (95 mm), the value for total charge passed established in 11.1 must be adjusted. The adjustment is made by multiplying the value established in 11.1 by the ratio of the cross-sectional areas of the standard and the actual specimens. That is:

$$Q_s = Q_x \times \left(\frac{3.75}{x}\right)^2 \quad (2)$$

where:

Q_s = charge passed (coulombs) through a 3.75-in. (95-mm) diameter specimen,

Q_x = charge passed (coulombs) through x in. diameter specimen, and

x = diameter (in.) of the nonstandard specimen.

11.3 Use Table 1 to evaluate the test results. These values were developed from data on slices of cores taken from laboratory slabs prepared from various types of concretes.

11.3.1 Factors which are known to affect chloride ion penetration include: water-cement ratio, the presence of polymeric admixtures, sample age, air-void system, aggregate type, degree of consolidation, and type of curing.

12. Report

12.1 Report the following, if known:

12.1.1 Source of core or cylinder, in terms of the particular location the core or cylinder represents,

12.1.2 Identification number of core or cylinder and specimen,

12.1.3 Location of specimen within core or cylinder,

12.1.4 Type of concrete, including binder type, water-cement ratio, and other relevant data supplied with samples,

12.1.5 Description of specimen, including presence and location of reinforcing steel, presence and thickness of overlay, and presence and thickness of surface treatment,

12.1.6 Curing history of specimen,

12.1.7 Unusual specimen preparation, for example, removal of surface treatment,

12.1.8 Test results, reported as the total charge passed over the test period (adjusted per 11.2), and

12.1.9 The qualitative chloride ion penetrability equivalent to the calculated charge passed (from Table 1).

13. Precision and Bias⁵

13.1 Precision:

13.1.1 *Single-Operator Precision*—The single operator coefficient of variation of a single test result has been found to be 12.3 % (Note 6). Therefore the results of two properly conducted tests by the same operator on concrete samples from the same batch and of the same diameter should not differ by more than 42 % (Note 6).

13.1.2 *Multilaboratory Precision*—The multilaboratory coefficient of variation of a single test result has been found to be 18.0 % (Note 6). Therefore results of two properly conducted tests in different laboratories on the same material should not differ by more than 51 % (Note 6). The average of three test results in two different laboratories should not differ by more than 42 % (Note 7).

NOTE 6—These numbers represent, respectively, the (1s %) and (d2s %) limits as described in Practice C 670. The precision statements are based on the variations in tests on three different concretes, each tested in

triplicate in eleven laboratories. All specimens had the same actual diameters, but lengths varied within the range $2 \pm \frac{1}{8}$ in. (51 ± 3 mm).

NOTE 7—Although the test method does not require the reporting of more than one test result, testing of replicate specimens is usually desirable. The precision statement for the averages of three results is given since laboratories frequently will run this number of specimens. When averages of three results are established in each laboratory, the multilaboratory coefficient of variation, s_{ML} is calculated as:

$$s_{ML} = \sqrt{\frac{s_{WL}^2}{3} + s_{BL}^2} \quad (3)$$

where:

s_{WL}^2 = within-laboratory variance and
 s_{BL}^2 = between-laboratory variance.

The percentage cited represents the (d2s %) limit based on the value for the multilaboratory coefficient of variation.

13.2 *Bias*—The procedure of this test method for measuring the resistance of concrete to chloride ion penetration has no bias because the value of this resistance can be defined only in terms of a test method.

14. Keywords

14.1 chloride content; corrosion; deicing chemicals; resistance-chloride penetration

⁵ Supporting data have been filed at ASTM International Headquarters and may be obtained by requesting Research Report RR: C09-1004.

REFERENCES

- (1) Whiting, D., "Rapid Determination of the Chloride Permeability of Concrete," *Final Report No. FHWA/RD-81/119*, Federal Highway Administration, August 1981, NTIS No. PB 82140724.
- (2) Whiting, D., "Permeability of Selected Concretes," *Permeability of Concrete*, SP-108, American Concrete Institute, Detroit, Michigan, 1988, pp. 195–222.
- (3) Whiting, D., and Dziedzic, W., "Resistance to Chloride Infiltration of Superplasticized Concrete as Compared with Currently Used Concrete Overlay Systems," *Final Report No. FHWA/OH-89/009*, Construction Technology Laboratories, May 1989.
- (4) Berke, N. S., Pfeifer, D. W., and Weil, T. G., "Protection Against Chloride-Induced Corrosion," *Concrete International*, Vol. 10, No. 12, December 1988, pp. 45–55.
- (5) Ozyildirim, C., and Halstead, W. J., "Use of Admixtures to Attain Low Permeability Concretes," *Final Report No. FHWA/VA-88-R11*, Virginia Transportation Research Council, February 1988, NTIS No. PB 88201264.

SUMMARY OF CHANGES

Committee C09 has identified the location of selected changes to this test method since the last issue, C 1202 – 07, that may impact the use of this test method. (Approved December 15, 2008)

(I) Revised 4.4.

ASTM International takes no position respecting the validity of any patent rights asserted in connection with any item mentioned in this standard. Users of this standard are expressly advised that determination of the validity of any such patent rights, and the risk of infringement of such rights, are entirely their own responsibility.

This standard is subject to revision at any time by the responsible technical committee and must be reviewed every five years and if not revised, either reapproved or withdrawn. Your comments are invited either for revision of this standard or for additional standards and should be addressed to ASTM International Headquarters. Your comments will receive careful consideration at a meeting of the responsible technical committee, which you may attend. If you feel that your comments have not received a fair hearing you should make your views known to the ASTM Committee on Standards, at the address shown below.

This standard is copyrighted by ASTM International, 100 Barr Harbor Drive, PO Box C700, West Conshohocken, PA 19428-2959, United States. Individual reprints (single or multiple copies) of this standard may be obtained by contacting ASTM at the above address or at 610-832-9585 (phone), 610-832-9555 (fax), or service@astm.org (e-mail); or through the ASTM website (www.astm.org).