



Standard Test Method for Monotonic Tensile Behavior of Continuous Fiber-Reinforced Advanced Ceramics with Solid Rectangular Cross-Section Test Specimens at Ambient Temperature¹

This standard is issued under the fixed designation C 1275; the number immediately following the designation indicates the year of original adoption or, in the case of revision, the year of last revision. A number in parentheses indicates the year of last reapproval. A superscript epsilon (ϵ) indicates an editorial change since the last revision or reapproval.

^{ε1} NOTE—The Warning note in 8.2.5.2 was editorially updated in June 2005.

1. Scope

1.1 This test method covers the determination of tensile behavior including tensile strength and stress-strain response under monotonic uniaxial loading of continuous fiber-reinforced advanced ceramics at ambient temperature. This test method addresses, but is not restricted to, various suggested test specimen geometries as listed in the appendix. In addition, specimen fabrication methods, testing modes (force, displacement, or strain control), testing rates (force rate, stress rate, displacement rate, or strain rate), allowable bending, and data collection and reporting procedures are addressed. Note that tensile strength as used in this test method refers to the tensile strength obtained under monotonic uniaxial loading where monotonic refers to a continuous nonstop test rate with no reversals from test initiation to final fracture.

1.2 This test method applies primarily to all advanced ceramic matrix composites with continuous fiber reinforcement: uni-directional (1-D), bi-directional (2-D), and tri-directional (3-D). In addition, this test method may also be used with glass (amorphous) matrix composites with 1-D, 2-D, and 3-D continuous fiber reinforcement. This test method does not address directly discontinuous fiber-reinforced, whisker-reinforced or particulate-reinforced ceramics, although the test methods detailed here may be equally applicable to these composites.

1.3 Values expressed in this test method are in accordance with the International System of Units (SI) and **IEEE/ASTM SI 10**.

1.4 *This standard does not purport to address all of the safety concerns, if any, associated with its use. It is the responsibility of the user of this standard to establish appropriate safety and health practices and determine the applicability of regulatory limitations prior to use.* Specific hazard statements are given in Section 7 and 8.2.5.2.

¹ This practice is under the jurisdiction of ASTM Committee C28 on Advanced Ceramics and is the direct responsibility of Subcommittee C28.07 on Ceramic Matrix Composites.

Current edition approved June 1, 2005. Published June 2005. Originally approved in 1994. Last previous edition approved in 2000 as C 1275 – 00.

2. Referenced Documents

2.1 ASTM Standards:²

C 1145 Terminology of Advanced Ceramics

C 1239 Practice for Reporting Uniaxial Strength Data and Estimating Weibull Distribution Parameters for Advanced Ceramics

D 3039/D 3039M Test Method for Tensile Properties of Polymer Matrix Composite Materials

D 3379 Test Method for Tensile Strength and Young's Modulus for High-Modulus Single-Filament Materials

D 3878 Terminology for Composite Materials

E 4 Practices for Force Verification of Testing Machines

E 6 Terminology Relating to Methods of Mechanical Testing

E 83 Practice for Verification and Classification of Extensometer System

E 177 Practice for Use of the Terms Precision and Bias in ASTM Test Methods

E 337 Test Method for Measuring Humidity with Psychrometer (the Measurement of Wet- and Dry-Bulb Temperatures)

E 691 Practice for Conducting an Interlaboratory Study to Determine the Precision of a Test Method

E 1012 Practice for Verification of Specimen Alignment Under Tensile Loading

IEEE/ASTM SI 10 American National Standard for Use of the International System of Units (SI): The Modern Metric System

3. Terminology

3.1 *Definitions*—The definitions of terms relating to tensile testing appearing in Terminology **E 6** apply to the terms used in this test method. The definitions of terms relating to advanced ceramics appearing in Terminology **C 1145** apply to the terms used in this test method. The definitions of terms relating to

² For referenced ASTM standards, visit the ASTM website, www.astm.org, or contact ASTM Customer Service at service@astm.org. For *Annual Book of ASTM Standards* volume information, refer to the standard's Document Summary page on the ASTM website.

fiber reinforced composites appearing in Terminology **D 3878** apply to the terms used in this test method. Pertinent definitions as listed in Practice **E 1012**, Terminology **C 1145**, Terminology **D 3878**, and Terminology **E 6** are shown in the following with the appropriate source given in parentheses. Additional terms used in conjunction with this test method are defined in the following:

3.1.1 *advanced ceramic, n*—highly engineered, high performance predominantly nonmetallic, inorganic, ceramic material having specific functional attributes. **C 1145**

3.1.2 *axial strain*—average longitudinal strains measured at the surface on opposite sides of the longitudinal axis of symmetry of the specimen by two strain-sensing devices located at the mid length of the reduced section. **E 1012**

3.1.3 *bending strain*—difference between the strain at the surface and the axial strain. In general, the bending strain varies from point to point around and along the reduced section of the specimen. **E 1012**

3.1.4 *breaking force*—force at which fracture occurs. **E 6**

3.1.5 *ceramic matrix composite*—material consisting of two or more materials (insoluble in one another), in which the major, continuous component (matrix component) is a ceramic, while the secondary component/s (reinforcing component) may be ceramic, glass-ceramic, glass, metal or organic in nature. These components are combined on a macroscale to form a useful engineering material possessing certain properties or behavior not possessed by the individual constituents.

3.1.6 *continuous fiber-reinforced ceramic matrix composite (CFCC)*—ceramic matrix composite in which the reinforcing phase consists of a continuous fiber, continuous yarn, or a woven fabric.

3.1.7 *gage length*—original length of that portion of the specimen over which strain or change of length is determined. **E 6**

3.1.8 *matrix-cracking stress*—applied tensile stress at which the matrix cracks into a series of roughly parallel blocks normal to the tensile stress.

3.1.9 *Discussion*—In some cases, the matrix cracking stress may be indicated on the stress-strain curve by deviation from linearity (proportional limit) or incremental drops in the stress with increasing strain. In other cases, especially with materials which do not possess a linear portion of the stress-strain curve, the matrix cracking stress may be indicated as the first stress at which a permanent offset strain is detected in the unloading stress-strain (elastic limit).

3.1.10 *modulus of elasticity*—ratio of stress to corresponding strain below the proportional limit. **E 6**

3.1.11 *modulus of resilience*—strain energy per unit volume required to elastically stress the material from zero to the proportional limit indicating the ability of the material to absorb energy when deformed elastically and return it when unloaded.

3.1.12 *modulus of toughness*—strain energy per unit volume required to stress the material from zero to final fracture indicating the ability of the material to absorb energy beyond the elastic range (that is, damage tolerance of the material).

3.1.13 *Discussion*—The modulus of toughness can also be referred to as the cumulative damage energy and as such is

regarded as an indication of the ability of the material to sustain damage rather than as a material property. Fracture mechanics methods for the characterization of CFCCs have not been developed. The determination of the modulus of toughness as provided in this test method for the characterization of the cumulative damage process in CFCCs may become obsolete when fracture mechanics methods for CFCCs become available.

3.1.14 *proportional limit stress*—greatest stress that a material is capable of sustaining without any deviation from proportionality of stress to strain (Hooke's law).

3.1.15 *Discussion*—Many experiments have shown that values observed for the proportional limit vary greatly with the sensitivity and accuracy of the testing equipment, eccentricity of loading, the scale to which the stress-strain diagram is plotted, and other factors. When determination of proportional limit is required, the procedure and sensitivity of the test equipment should be specified. (See Terminology **E 6**.)

3.1.16 *percent bending*—bending strain times 100 divided by the axial strain. **E 1012**

3.1.17 *slow crack growth*—subcritical crack growth (extension) which may result from, but is not restricted to, such mechanisms as environmentally-assisted stress corrosion or diffusive crack growth.

3.1.18 *tensile strength*—maximum tensile stress which a material is capable of sustaining. Tensile strength is calculated from the maximum load during a tension test carried to rupture and the original cross-sectional area of the specimen. **E 6**

4. Significance and Use

4.1 This test method may be used for material development, material comparison, quality assurance, characterization, and design data generation.

4.2 Continuous fiber-reinforced ceramic matrix composites generally characterized by fine grain sized (<50 μm) matrices and ceramic fiber reinforcements are candidate materials for structural applications requiring high degrees of wear and corrosion resistance, and high-temperature inherent damage tolerance (that is, toughness). In addition, continuous fiber-reinforced glass (amorphous) matrix composites are candidate materials for similar but possibly less-demanding applications. Although flexural test methods are commonly used to evaluate strengths of monolithic advanced ceramics, the non-uniform stress distribution of the flexure specimen in addition to dissimilar mechanical behavior in tension and compression for CFCCs lead to ambiguity of interpretation of strength results obtained from flexure tests for CFCCs. Uniaxial-loaded tensile strength tests provide information on mechanical behavior and strength for a uniformly-stressed material.

4.3 Unlike monolithic advanced ceramics which fracture catastrophically from a single dominant flaw, CFCCs generally experience “graceful” fracture from a cumulative damage process. Therefore, the volume of material subjected to a uniform tensile stress for a single uniaxially-loaded tensile test may not be as significant a factor in determining the ultimate strengths of CFCCs. However, the need to test a statistically significant number of tensile specimens is not obviated. Therefore, because of the probabilistic nature of the strength distributions of the brittle matrices of CFCCs, a sufficient number of

specimens at each testing condition is required for statistical analysis and design. Studies to determine the exact influence of specimen volume on strength distributions for CFCCs have not been completed. It should be noted that tensile strengths obtained using different recommended tensile specimens with different volumes of material in the gage sections may be different due to these volume differences.

4.4 Tensile tests provide information on the strength and deformation of materials under uniaxial tensile stresses. Uniform stress states are required to effectively evaluate any non-linear stress-strain behavior which may develop as the result of cumulative damage processes (for example, matrix cracking, matrix/fiber debonding, fiber fracture, delamination, etc.) which may be influenced by testing mode, testing rate, processing or alloying effects, or environmental influences. Some of these effects may be consequences of stress corrosion or subcritical (slow) crack growth that can be minimized by testing at sufficiently rapid rates as outlined in this test method.

4.5 The results of tensile tests of test specimens fabricated to standardized dimensions from a particular material or selected portions of a part, or both, may not totally represent the strength and deformation properties of the entire, full-size end product or its in-service behavior in different environments.

4.6 For quality control purposes, results derived from standardized tensile test specimens may be considered indicative of the response of the material from which they were taken for, given primary processing conditions and post-processing heat treatments.

4.7 The tensile behavior and strength of a CFCC are dependent on its inherent resistance to fracture, the presence of flaws, or damage accumulation processes, or both. Analysis of fracture surfaces and fractography, though beyond the scope of this test method, is highly recommended.

5. Interferences

5.1 Test environment (vacuum, inert gas, ambient air, etc.) including moisture content (for example, relative humidity) may have an influence on the measured tensile strength. In particular, the behavior of materials susceptible to slow crack growth fracture will be strongly influenced by test environment and testing rate. Testing to evaluate the maximum strength potential of a material should be conducted in inert environments or at sufficiently rapid testing rates, or both, so as to minimize slow crack growth effects. Conversely, testing can be conducted in environments and testing modes and rates representative of service conditions to evaluate material performance under use conditions. When testing is conducted in uncontrolled ambient air with the intent of evaluating maximum strength potential, relative humidity and temperature must be monitored and reported. Testing at humidity levels >65 % relative humidity (RH) is not recommended and any deviations from this recommendation must be reported.

5.2 Surface preparation of test specimens, although normally not considered a major concern in CFCCs, can introduce fabrication flaws that may have pronounced effects on tensile mechanical properties and behavior (for example, shape and level of the resulting stress-strain curve, tensile strength and strain, proportional limit stress and strain, etc.). Machining

damage introduced during specimen preparation can be either a random interfering factor in the determination of ultimate strength of pristine material (that is, increased frequency of surface initiated fractures compared to volume initiated fractures), or an inherent part of the strength characteristics to be measured. Surface preparation can also lead to the introduction of residual stresses. Universal or standardized test methods of surface preparation do not exist. It should be understood that final machining steps may, or may not negate machining damage introduced during the initial machining. Thus, specimen fabrication history may play an important role in the measured strength distributions and should be reported. In addition, the nature of fabrication used for certain composites (for example, chemical vapor infiltration or hot pressing) may require the testing of test specimens in the as-processed condition (that is, it may not be possible to machine the specimen faces).

5.3 Bending in uniaxial tensile tests can cause or promote non-uniform stress distributions with maximum stresses occurring at the specimen surface leading to non-representative fractures originating at surfaces or near geometrical transitions. In addition, if deformations or strains are measured at surfaces where maximum or minimum stresses occur, bending may introduce over or under measurement of strains depending on the location of the strain-measuring device on the specimen. Similarly, fracture from surface flaws may be accentuated or suppressed by the presence of the non-uniform stresses caused by bending.

5.4 Fractures that initiate outside the uniformly-stressed gage section of a test specimen may be due to factors such as stress concentrations or geometrical transitions, extraneous stresses introduced by gripping, or strength-limiting features in the microstructure of the specimen. Such non-gage section fractures will normally constitute invalid tests. In addition, for face-loaded geometries, gripping pressure is a key variable in the initiation of fracture. Insufficient pressure can shear the outer plies in laminated CFCCs; while too much pressure can cause local crushing of the CFCC and fracture in the vicinity of the grips.

6. Apparatus

6.1 *Testing Machines*—Machines used for tensile testing shall conform to the requirements of Practice E 4. The force used in determining tensile strength shall be accurate within $\pm 1\%$ at any force within the selected force range of the testing machine as defined in Practice E 4. A schematic showing pertinent features of the tensile testing apparatus is shown in Fig. 1.

6.2 Gripping Devices:

6.2.1 *General*—Various types of gripping devices may be used to transmit the measured load applied by the testing machine to the test specimens. The brittle nature of the matrices of CFCCs requires a uniform interface between the grip components and the gripped section of the specimen. Line or point contacts and non-uniform pressure can produce Hertzian-type stresses leading to crack initiation and fracture of the test specimen in the gripped section. Gripping devices can

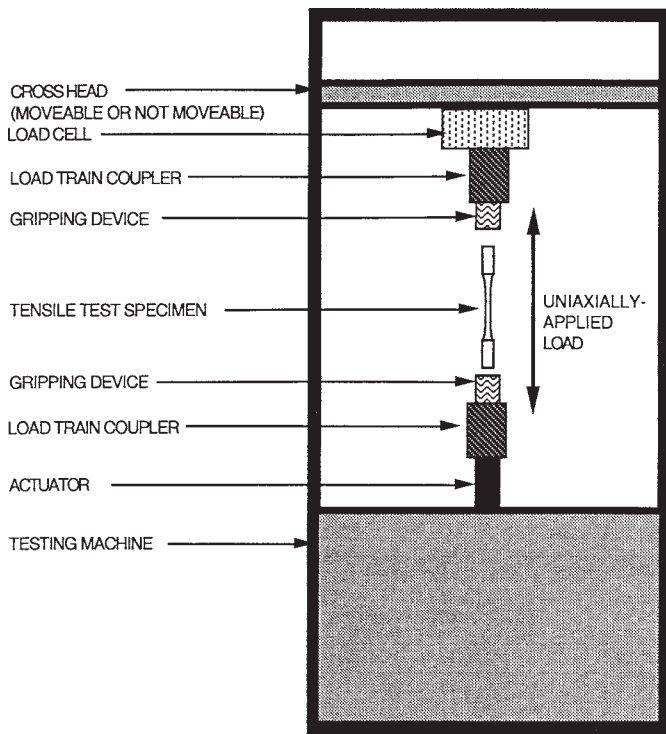

FIG. 1 Schematic Diagram of One Possible Apparatus for Conducting a Uniaxially-Loaded Tensile Test

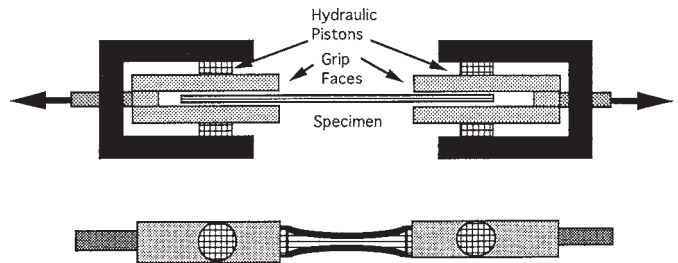

FIG. 2 Example of a Direct Lateral Pressure Grip Face for a Face-Loaded Grip Interface

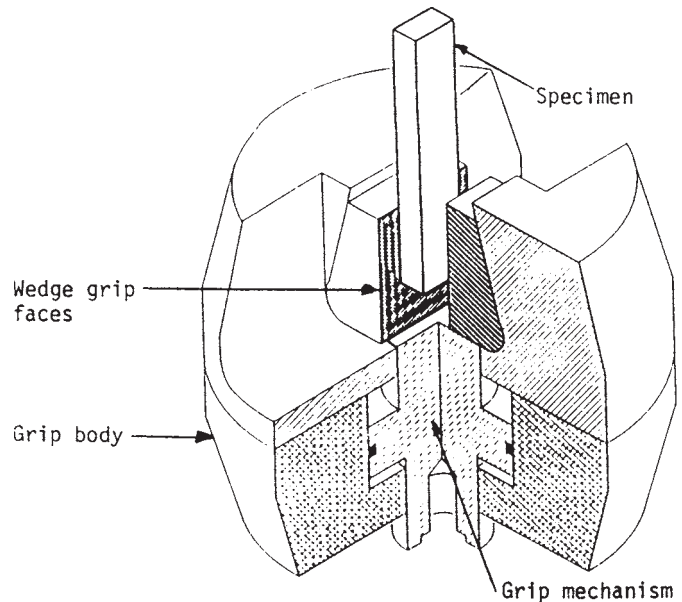

FIG. 3 Example of Indirect Wedge-Type Grip Faces for a Face-Loaded Grip Interface

be classed generally as those employing active and those employing passive grip interfaces as discussed in the following sections.

6.2.2 Active Grip Interfaces—Active grip interfaces require a continuous application of a mechanical, hydraulic, or pneumatic force to transmit the load applied by the test machine to the test specimen. Generally, these types of grip interfaces cause a force to be applied normal to the surface of the gripped section of the specimen. Transmission of the uniaxial force applied by the test machine is then accomplished by friction between the test specimen and the grip faces. Thus, important aspects of active grip interfaces are uniform contact between the gripped section of the test specimen and the grip faces and constant coefficient of friction over the grip/specimen interface.

6.2.2.1 For flat test specimens, face-loaded grips, either by direct lateral pressure grip faces (1)³ or by indirect wedge-type grip faces, act as the grip interface (2) as illustrated in Fig. 2 and Fig. 3, respectively. Generally, close tolerances are required for the flatness and parallelism as well as for the wedge angle of the wedge grip faces. In addition, the thickness, flatness, and parallelism of the gripped section of the specimen must be within similarly close tolerances to promote uniform contact at the test specimen/grip interface. Tolerances will vary depending on the exact configuration as shown in the appropriate test specimen drawings.

6.2.2.2 Sufficient lateral pressure must be applied to prevent slippage between the grip face and the specimen. Grip surfaces

that are scored or serrated with a pattern similar to that of a single-cut file have been found satisfactory. A fine serration appears to be the most satisfactory. The serrations should be kept clean and well defined but not overly sharp. The length and width of the grip faces should be equal to or greater than the respective length and width of the gripped sections of the test specimen.

6.2.3 Passive Grip Interfaces—Passive grip interfaces transmit the force applied by the test machine to the test specimen through a direct mechanical link. Generally, these mechanical links transmit the test forces to the specimen via geometrical features of the test specimens such as shank shoulders or holes in the gripped head. Thus, the important aspect of passive grip interfaces is uniform contact between the gripped section of the test specimen and the grip faces.

6.2.3.1 For flat test specimens, passive grips may act either through edge-loading via grip interfaces at the shoulders of the specimen shank (3) or by combinations of face-loading and pin loading via pins at holes in the gripped specimen head (4, 5). Generally, close tolerances of linear and angular dimensions of shoulder and grip interfaces are required to promote uniform contact along the entire test specimen/grip interface as well as to provide for non-eccentric loading as shown in Fig. 4. In

³ The boldface numbers given in parentheses refer to a list of references at the end of the text.

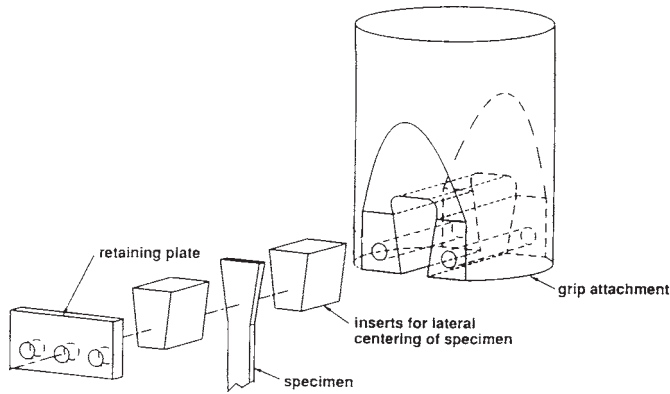

FIG. 4 Example of an Edge-Loaded, Passive Grip Interface (3)

addition, moderately close tolerances are required for center line coincidence and diameters of the pins and hole as indicated in Fig. 5.

6.2.3.2 When using edge-loaded specimen, lateral centering of the test specimen within the grip attachments is accomplished by use of wedge type inserts machined to fit within the grip cavity. In addition, wear of the grip cavity can be reduced by use of the thin brass sheets between the grip and test specimen without adversely affecting specimen alignment.

6.2.3.3 The pins in the face/pin loaded grip are primarily for alignment purposes with a secondary role of force transmission. Primary load transmission is through face-loading via mechanically actuated wedge grip faces. Proper tightening of the wedge grip faces against the test specimen to prevent slipping but avoid compressive fracture of the test specimen gripped section must be determined for each material and test specimen type.

6.2.3.4 Note that passive grips employing single pins in each gripped section of the test specimen as the primary force transfer mechanism are not recommended. Relatively low interfacial shear strengths compared to longitudinal tensile strengths in CFCCs (particularly for 1-D reinforced materials loaded along the fiber direction) may promote non-gage section

fractures along interfaces particularly at geometric transitions or at discontinuities such as holes.

6.3 Load Train Couplers:

6.3.1 General—Various types of devices (load train couplers) may be used to attach the active or passive grip interface assemblies to the testing machine. The load train couplers in conjunction with the type of gripping device play major roles in the alignment of the load train and thus subsequent bending imposed in the specimen. Load train couplers can be classified generally as fixed and non-fixed as discussed in the following sections. Note that use of well-aligned fixed or self-aligning non-fixed couplers does not automatically guarantee low bending in the gage section of the tensile specimen. Generally, well-aligned fixed or self-aligning non-fixed couplers provide for well aligned load trains, but the type and operation of grip interfaces as well as the as-fabricated dimensions of the tensile specimen can add significantly to the final bending imposed in the gage section of the specimen.

6.3.1.1 Regardless of which type of coupler is used, alignment of the testing system shall be verified at a minimum at the beginning and end of a test series unless the conditions for verifying alignment as detailed in X1.1 are otherwise met. A test series is interpreted to mean a discrete group of tests on individual specimens conducted within a discrete period of time on a particular material configuration, test specimen geometry, test conditions, or other uniquely definable qualifier (for example, a test series composed of material A comprising ten specimens of geometry B tested at a fixed rate in strain control to final fracture in ambient air). An additional verification of alignment is recommended, although not required, at the middle of the test series. Either a dummy or actual test specimen and the alignment verification procedures detailed in the appendix must be used. Allowable bending requirements are discussed in 6.5. Tensile specimens used for alignment verification should be equipped with a recommended eight separate longitudinal strain gages to determine bending contributions from both eccentric and angular misalignment of the grip heads. Ideally the verification specimen should be of

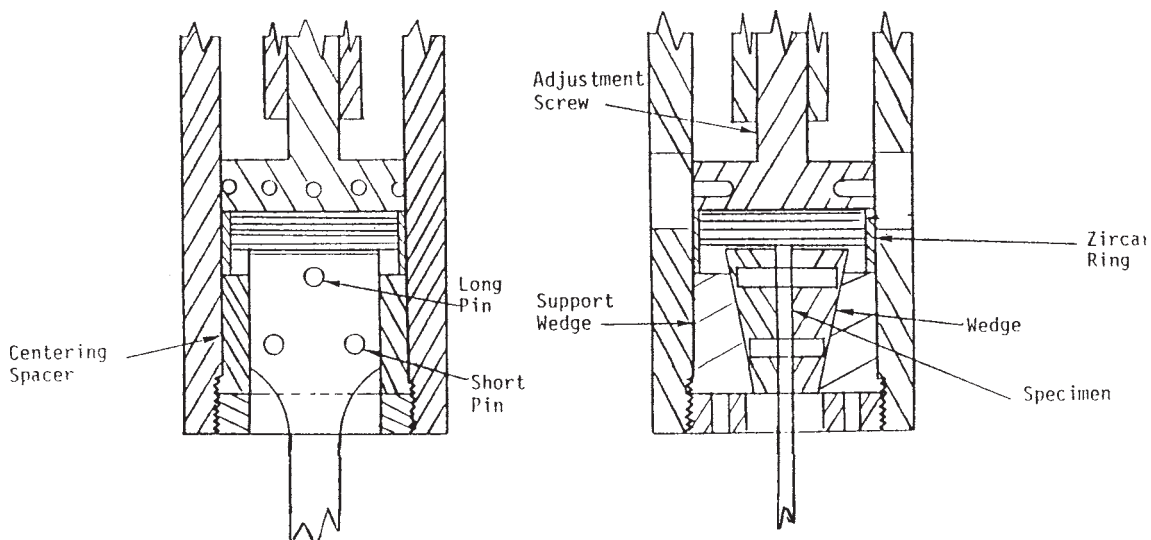

FIG. 5 Example of Pin/Face-Loaded Passive Grip Interface (4)

identical material to that being tested. However, in the case of CFCCs, the type of reinforcement or degree of residual porosity may complicate the consistent and accurate measurement of strain. Therefore, an alternate material (isotropic, homogeneous, continuous) with elastic modulus, elastic strain capability, and hardness similar to the test material is recommended. In addition, dummy test specimens used for alignment verification, should have the same geometry and dimensions of the actual test specimens as well as similar mechanical properties as the test material to ensure similar axial and bending stiffness characteristics as the actual test specimen and material.

6.3.2 Fixed Load Train Couplers—Fixed couplers may incorporate devices that require either a one-time, pre-test alignment adjustment of the load train which remains constant for all subsequent tests or an *in situ*, pre-test alignment of the load train that is conducted separately for each specimen and each test. Such devices (6, 7) usually employ angularity and concentricity adjusters to accommodate inherent load train misalignments. Regardless of which method is used, alignment verification must be performed as discussed in 6.3.1.1.

6.3.2.1 Fixed load train couplers are preferred in monotonic testing CFCCs because of the “graceful” fracture process in these materials. During this “graceful” fracture process, the fixed coupler tends to hold the test specimen in an aligned position, and thus, provides a continuous uniform stress across the remaining ligament of the gage section.

6.3.3 Non-Fixed Load Train Couplers—Non-fixed couplers may incorporate devices that promote self-alignment of the load train during the movement of the crosshead or actuator. Generally such devices rely upon freely moving linkages to eliminate applied moments as the load train components are loaded. Knife edges, universal joints, hydraulic couplers or air bearings are examples (4, 8, 9) of such devices. Examples of two such devices are shown in Fig. 6. Although non-fixed load train couplers are intended to be self-aligning and thus elimi-

nate the need to evaluate the bending in the specimen for each test, the operation of the couplers must be verified as discussed in 6.3.1.1.

6.3.3.1 Non fixed load train couplers are useful in rapid test rate or constant load testing of CFCCs where the “graceful” fracture process is not as apparent. If the material exhibits “graceful” fracture the self aligning feature of the non-fixed coupler will allow rotation of the gripped section of the specimen thus promoting a non-uniform stress in the remaining ligament of the gage section.

6.4 Strain Measurement—Strain should be determined by means of either a suitable extensometer or strain gages. If Poisson’s ratio is to be determined, the test specimen must be instrumented to measure strain in both longitudinal and lateral directions.

6.4.1 Extensometers used for tensile testing of CFCC test specimens shall satisfy Test Method E 83, Class B-1 requirements and are recommended to be used in place of strain gages for test specimens with gage lengths of ≥ 25 mm and shall be used for high-performance tests beyond the range of strain gage applications. Extensometers shall be calibrated periodically in accordance with Test Method E 83. For extensometers mechanically attached to the specimen, the attachment should be such as to cause no damage to the specimen surface. In addition, the weight of the extensometer should be supported so as not to introduce bending greater than that allowed in 6.5.

6.4.2 Although not recommended for the actual testing, strain can also be determined directly from strain gages. If Poisson’s ratio is to be determined, the test specimen must be instrumented to measure strain in both longitudinal and lateral directions. Unless it can be shown that strain gage readings are not unduly influenced by localized strain events such as fiber crossovers, strain gages should not be less than 9 to 12 mm in length for the longitudinal direction and not less than 6 mm in length for the transverse direction. Note that larger strain gages than those recommended here may be required for fabric reinforcements to average the localized strain effects of the fiber crossovers. The strain gages, surface preparation, and bonding agents should be chosen to provide adequate performance on the subject materials and suitable strain recording equipment should be employed. Note that many CFCCs may exhibit high degrees of porosity and surface roughness and therefore require surface preparation including surface filling before the strain gages can be applied.

6.5 Allowable Bending—Analytical and empirical studies (10) have concluded that for negligible effects on the estimates of the strength distribution parameters (for example, Weibull modulus, \hat{m} , and characteristic strength, $\hat{\sigma}_0$) of monolithic advanced ceramics, allowable percent bending as defined in Practice E 1012 should not exceed five. These conclusions (10) assume that tensile strength fractures are due to single fracture origins in the volume of the material, all tensile test specimens experienced the same level of bending, and that Weibull modulus, \hat{m} , was constant.

6.5.1 Similar studies of the effect of bending on the tensile strength distributions of CFCCs do not exist. Until such information is forthcoming for CFCCs, this test method adopts

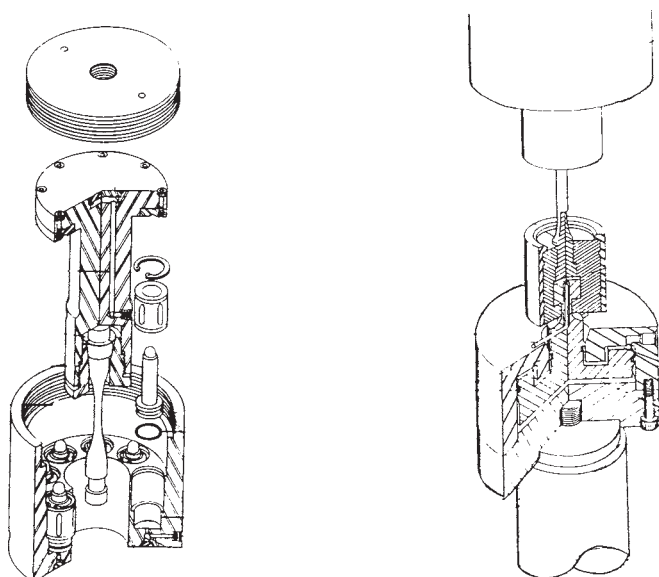

FIG. 6 Examples of Hydraulic, Self-Aligning, Non Fixed Load Train Couplers (8, 9)

the recommendations for tensile testing of monolithic advanced ceramics. Therefore, the recommended maximum allowable percent bending at the onset of the cumulative fracture process (for example, matrix cracking stress) for test specimens tested under this test method is five. However, it should be noted that unless all specimens are properly strain gaged and percent bending monitored until the onset of the cumulative fracture process, there will be no record of percent bending at the onset of fracture for each specimen. Therefore, the testing system shall be verified using the procedure detailed in the appendix such that percent bending does not exceed five at a mean strain equal to either one half the anticipated strain at the onset of the cumulative fracture process (for example, matrix cracking stress) or a strain of 0.0005 (that is, 500 microstrain) whichever is greater. This verification shall be conducted at a minimum at the beginning and end of each test series as recommended in 6.3.1.1. An additional verification of alignment is recommended, although not required, at the middle of the test series.

6.6 Data Acquisition—At the minimum, autographic record of applied load and gage section elongation or strain versus time should be obtained. Either analog chart recorders or digital data acquisition systems can be used for this purpose although a digital record is recommended for ease of later data analysis. Ideally, an analog chart recorder or plotter should be used in conjunction with the digital data acquisition system to provide an immediate record of the test as a supplement to the digital record. Recording devices shall be accurate to within $\pm 0.1\%$ for the entire testing system including readout unit as specified in Practices E 4 and shall have a minimum data acquisition rate of 10 Hz with a response of 50 Hz deemed more than sufficient.

6.6.1 Strain or elongation of the gage section, or both, should be recorded either similarly to the force or as independent variables of force. Cross-head displacement of the test machine may also be recorded but should not be used to define displacement or strain in the gage section especially when self-aligning couplers are used in the load train.

6.7 Dimension-Measuring Devices—Micrometers and other devices used for measuring linear dimensions should be accurate and precise to at least one half the smallest unit to which the individual dimension is required to be measured. For the purposes of this test method, cross-sectional dimensions should be measured to within 0.02 mm requiring dimension measuring devices with accuracies of 0.01 mm.

7. Hazards

7.1 During the conduct of this test method, the possibility of flying fragments of broken test material is high. The brittle nature of advanced ceramics and the release of strain energy contribute to the potential release of uncontrolled fragments upon fracture. Means for containment and retention of these fragments for later fractographic reconstruction and analysis is highly recommended.

7.2 Exposed fibers at the edges of CFCC test specimens present a hazard due to the sharpness and brittleness of the ceramic fiber. All those required to handle these materials should be well informed of such conditions and the proper handling techniques.

8. Test Specimens

8.1 Test Specimen Geometry:

8.1.1 General—The geometry of tensile test specimen is dependent on the ultimate use of the tensile strength data. For example, if the tensile strength of an as-fabricated component is required, the dimensions of the resulting tensile specimen may reflect the thickness, width, and length restrictions of the component. If it is desired to evaluate the effects of interactions of various constituent materials for a particular CFCC manufactured via a particular processing route, then the size of the test specimen and resulting gage section will reflect the desired volume to be sampled. In addition, grip interfaces and load train couplers as discussed in Section will influence the final design of the test specimen geometry.

8.1.1.1 The following sections discuss the more common, and thus proven, of these tensile test specimen geometries although any geometry is acceptable if it meets the gripping, fracture location, and bending requirements of this test method. Deviations from the recommended geometries may be necessary depending upon the particular CFCC being evaluated. Stress analyses of untried test specimens should be conducted to ensure that stress concentrations that can lead to undesired fractures outside the gage sections do not exist. It should be noted that contoured specimens by their nature contain inherent stress concentrations due to geometric transitions. Stress analyses can indicate the magnitude of such stress concentrations while revealing the success of producing a uniform tensile stress state in the gage section of the test specimen.

8.1.1.2 Generally, specimens with contoured gage sections (transition radiuses of >50 mm) are preferred to promote the tensile stresses with the greatest values in the uniformly-stressed gage section (II) while minimizing the stress concentration due to the geometrical transition of the radius. However, in certain instances, (for example, 1-D CFCCs tested along the direction of the fibers) low interfacial shear strength relative to the tensile strength in the fiber direction will cause splitting of the test specimen initiating at the transition region between the gage section and the gripped section of the test specimen with the split propagating along the fiber direction leading to fracture of the specimen. In these cases, straight-sided (that is, non-contoured) specimens as shown in Fig. 7, may be required for determining the tensile strength behavior of the CFCC. In other instances, a particular fiber weave or processing route will preclude fabrication of test specimens with reduced gage sections, thus requiring implementation of straight-sided specimens. Straight-sided test specimens may be gripped in any of the methods discussed here although active gripping systems are recommended for minimizing non-gage section fractures.

8.1.2 Edge-Loaded Flat Tensile Test Specimens—Fig. 8 and Fig. 9 show examples of edge-loaded test specimens which utilize the lateral compressive stresses developed at the test specimen/grip interface at the gripped section as the test specimen is pulled into the wedge of the grip. This type of geometry has been successfully employed for the evaluation of 1-D, 2-D, and 3-D CFCCs. Of particular concern with this geometry is the proper and consistent angle of the edge loaded shank as shown in Fig. 8 and Fig. 9. Thus, the edge-loaded

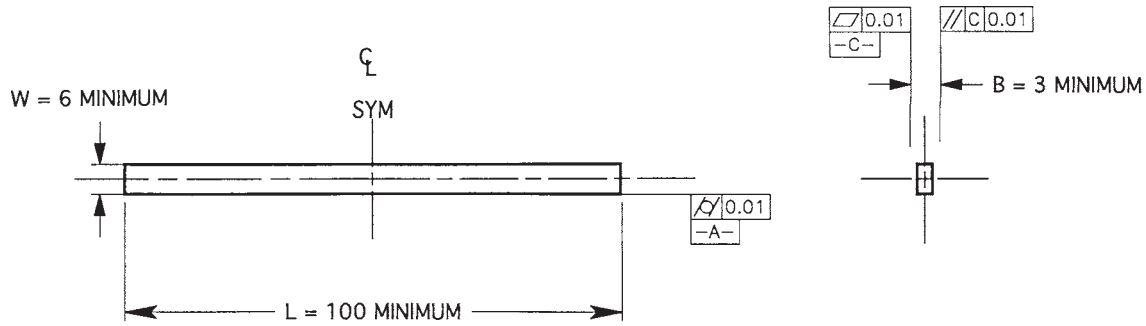

NOTE: 1) MINIMUM L = 100 mm WITH 25 mm GAGE SECTION. MINIMUM W = 6 mm.
 2) SURFACE FINISH 0.5- 1.0 μm ALL OVER EXCEPT END FACES WHICH MAY BE 1.0-2.0 μm .
 3) FINAL GRIND OF GAGE SECTION TO BE LONGITUDINAL

Tensile Specimen for CFCCs
mm X.X = 0.1, X.XX = 0.01, X.XXX = 0.001
SCALE: NTS

FIG. 7 Example of Straight-Sided Test Specimen Geometry

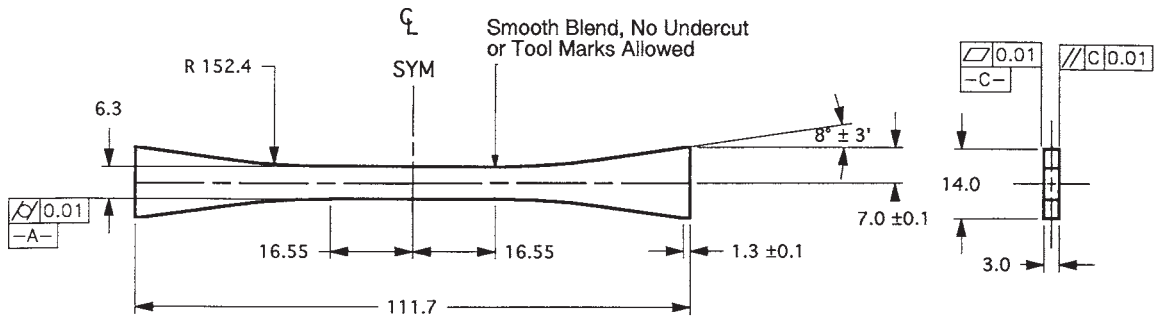

NOTE: 1) FINAL GRIND OF GAGE SECTION TO BE LONGITUDINAL

Tensile Specimen for CFCCs
mm X.X = 0.1, X.XX = 0.01, X.XXX = 0.001
SCALE: NTS

FIG. 8 Example of a Contoured, Edge-Loaded Test Specimen Geometry (3)

geometry may require somewhat intensive fabrication and inspection procedures.

8.1.3 *Face-Loaded Flat Tensile Test Specimens*—Fig. 10, Fig. 11, and Fig. 12 show examples of face-loaded specimens that exploit the friction at the test specimen/grip interface to transmit the uniaxial force applied by the test machine. Important tolerances for the face-loaded geometry include parallelism and flatness of faces all of which will vary depending on the exact configuration as shown in the appropriate specimen drawings.

8.1.3.1 For face-loaded specimens, especially for straight sided (that is, non-contoured) specimens, end tabs may be required to provide a compliant layer for gripping. Balanced 0/90° cross-ply tabs made from unidirectional non-woven

E-glass have proven to be satisfactory for certain fiber-reinforced polymers (see Test Method D 3039). For CFCCs, fiber-glass reinforced epoxy, PMR, and carbon fiber-reinforced resin tab materials have been used successfully (11). However metallic tabs (for example, aluminum alloys) may be satisfactory as long as the tabs are strain compatible (having a similar elastic modulus as the CFCC) with the CFCC material being tested. Each beveled tab (bevel angle <math><15^\circ</math>) should be a minimum of 30 mm long, the same width of the specimen, and have the total thickness of the tabs on the order of the thickness of the test specimen. Any high-elongation (tough) adhesive system may be used with the length of the tabs determined by the shear strength of the adhesive, size of the specimen, and estimated strength of the composite. In any case, a significant

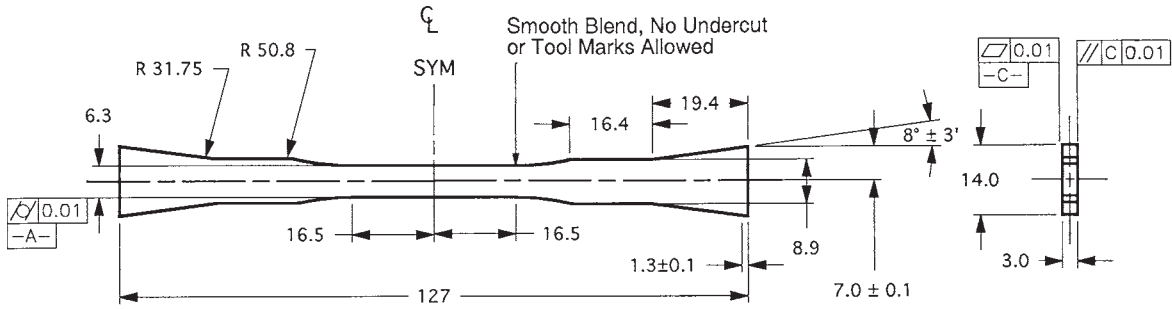

NOTE: 1) FINAL GRIND OF GAGE SECTION TO BE LONGITUDINAL

Tensile Specimen for CFCCs
mm X.X = 0.1, X.XX = 0.01, X.XXX = 0.001
SCALE: NTS

FIG. 9 Example of a Contoured, Edge-Loaded Test Specimen Geometry (3)

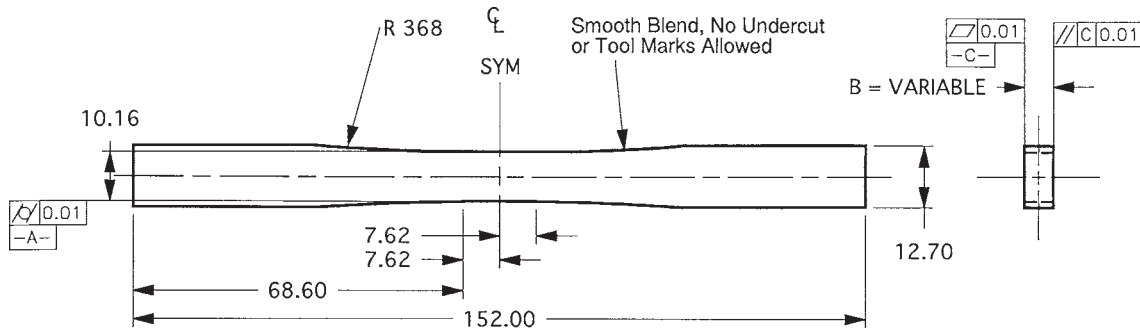

NOTE: 1) SURFACE FINISH 0.5- 1.0 μm ALL OVER EXCEPT END FACES WHICH MAY BE 1.0-2.0 μm .
2) FINAL GRIND OF GAGE SECTION TO BE LONGITUDINAL

Tensile Specimen for CFCCs
mm X.X = 0.1, X.XX = 0.01, X.XXX = 0.001
SCALE: NTS

FIG. 10 Example of Contoured, Face-Loaded Test Specimen Geometry (11)

fraction ($\geq 20\%$) of fractures within one test specimen width of the tab shall be cause to re-examine the tab materials and configuration, gripping method and adhesive, and to make necessary adjustments to promote fracture within the gage section. Fig. 13 shows an example of tab design which has been used successfully with CFCCs (11).

8.1.4 *Pin/Face-Loaded Flat Tensile Specimens*—The specimens shown in Figs. 14-16 employ combinations of pin and face loading to transmit the uniaxial force of the test machine to the specimen. Close tolerances of hole/pin diameters and center lines are required to ensure proper specimen alignment in the grips and transmission of the forces. The face-loaded part of the geometry provides the primary load transmission mechanisms in these test specimens. Important tolerances for the

face-loaded part of the geometry include parallelism and flatness of faces both of which will vary depending on the exact configuration as shown in the appropriate test specimen drawings. Thus the pin/face loaded geometry may require somewhat intensive fabrication procedures.

8.1.4.1 Note that test specimens requiring single pins in each gripped section of the specimen as the primary force transfer mechanism are not recommended. Relatively low interfacial shear strengths compared to longitudinal tensile strengths in CFCCs (particularly for 1-D reinforced materials loaded along the fiber direction) may promote non-gage section fractures along interfaces particularly at geometric transitions or at discontinuities such as holes.

8.2 *Specimen Preparation:*

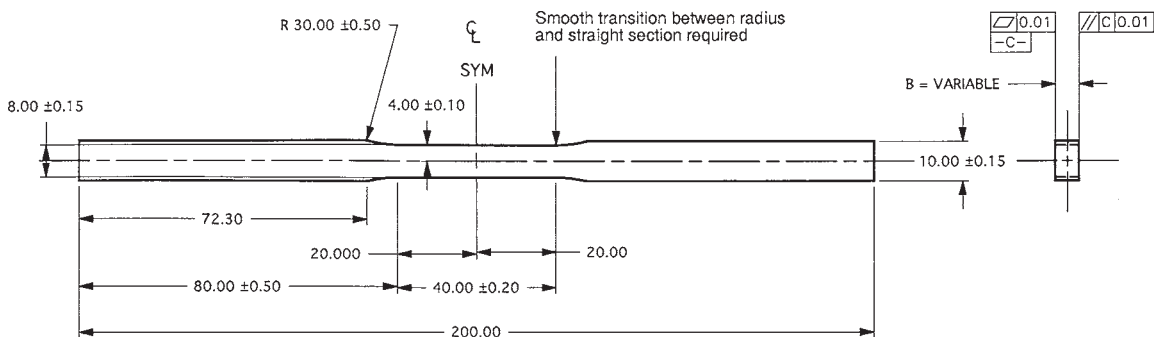

NOTE: 1) SURFACE FINISH 0.5- 1.0 μm ALL OVER EXCEPT END FACES WHICH MAY BE 1.0-2.0 μm .
2) FINAL GRIND OF GAGE SECTION TO BE LONGITUDINAL

Tensile Specimen for CFCCs
mm X.X = 0.1, X.XX = 0.01, X.XXX = 0.001
SCALE: NTS

FIG. 11 Example of a Contoured, Face-Loaded Test Specimen Geometry

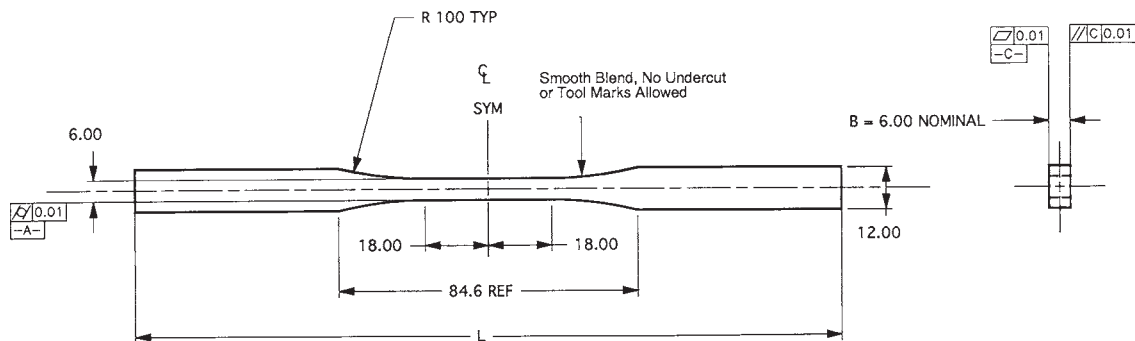

NOTE: 1) MINIMUM 'L' = 175 mm (for elevated temperatures) MAXIMUM 'L' = 200 mm.
2) SURFACE FINISH 0.5- 1.0 μm ALL OVER EXCEPT END FACES WHICH MAY BE 1.0-2.0 μm .
3) FINAL GRIND OF GAGE SECTION TO BE LONGITUDINAL

Tensile Specimen for CFCCs
mm X.X = 0.1, X.XX = 0.01, X.XXX = 0.001
SCALE: NTS

FIG. 12 Example of a Contoured, Face-Loaded Test Specimen Geometry

8.2.1 Depending upon the intended application of the tensile strength data, use one of the following specimen preparation procedures. Regardless of the preparation procedure used, sufficient details regarding the procedure must be reported to allow replication.

8.2.2 *As-Fabricated*—The tensile test specimen should simulate the surface/edge conditions and processing route of an application where no machining is used; for example, as-cast, sintered, or injection molded part. No additional machining specifications are relevant. As-processed test specimens might possess rough surface textures and nonparallel edges and as such may cause excessive misalignment or be prone to nongage section fractures, or both.

8.2.3 *Application-Matched Machining*— The tensile test specimen should have the same surface/edge preparation as that given to the component. Unless the process is proprietary, the report should be specific about the stages of material removal, wheel grits, wheel bonding, amount of material removed per pass, and type of coolant used.

8.2.4 *Customary Practices*—In instances where customary machining procedure has been developed that is completely satisfactory for a class of materials (that is, it induces no

unwanted surface/subsurface damage or residual stresses), this procedure should be used.

8.2.5 *Standard Procedure*—In instances where 8.2.2 through 8.2.4 are not appropriate, 8.2.5 should apply. Studies to evaluate the machinability of CFCCs have not been completed. Therefore, the standard procedure of 8.2.5 can be viewed as starting-point guidelines and a more stringent procedure may be necessary.

8.2.5.1 All grinding or cutting should be done with ample supply of appropriate filtered coolant to keep the workpiece and grinding wheel constantly flooded and particles flushed. Grinding can be done in at least two stages, ranging from coarse to fine rate of material removal. All cutting can be done in one stage appropriate for the depth of cut.

8.2.5.2 Stock removal rate should be on the order of 0.03 mm per pass using diamond tools that have between 320 and 600 grit. Remove equal stock from each face where applicable. (**Warning**—Care should be exercised in storage and handling of finished test specimens to avoid the introduction of random and severe flaws. In addition, attention should be given to pre-test storage of test specimens in controlled environments or

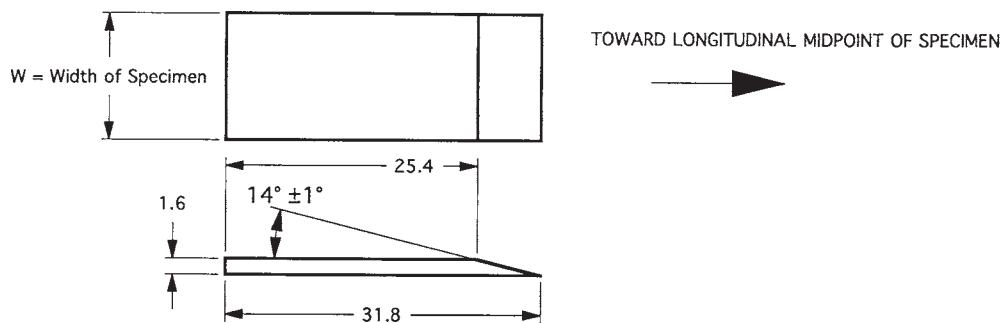

- NOTE: 1) SURFACE FINISH 0.5- 1.0 μm ALL OVER EXCEPT END FACES WHICH MAY BE 1.0-2.0 μm .
 2) FINAL GRIND OF GAGE SECTION TO BE LONGITUDINAL
 3) ANGLE OF BEVEL SHOULD BE $\leq 15^\circ$

Tabs for Tensile Specimen for CFCCs mm X.X = 0.1, X.XX = 0.01, X.XXX = 0.001 SCALE: NTS

FIG. 13 Example of a Beveled Tab Successfully Used with Face-Loaded CFCC Tensile Test Specimens (11)

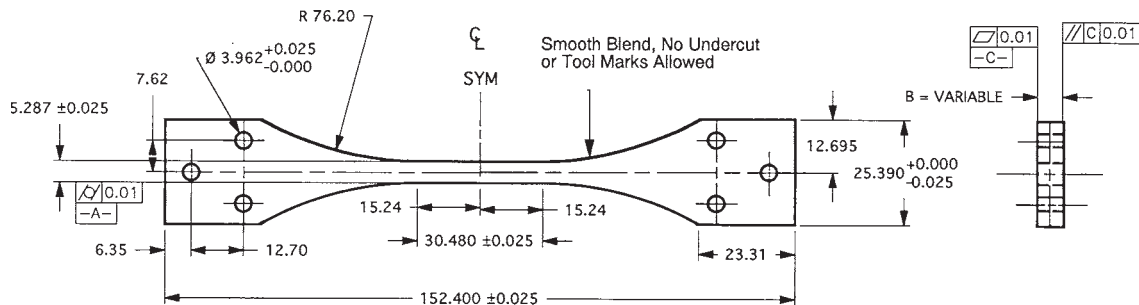

- NOTE: 1) SURFACE FINISH 0.5- 1.0 μm ALL OVER EXCEPT END FACES WHICH MAY BE 1.0-2.0 μm .
 2) FINAL GRIND OF GAGE SECTION TO BE LONGITUDINAL

Tensile Specimen for CFCCs mm X.X = 0.1, X.XX = 0.01, X.XXX = 0.001 SCALE: NTS
--

FIG. 14 Example of a Contoured, Pin/Face-Loaded Test Specimen Geometry (4)

desiccators to avoid unquantifiable environmental degradation of specimens prior to testing.)

8.3 *Number of Test Specimens*—A minimum of five test specimens tested validly is required for the purposes of estimating a mean. A greater number of test specimens tested validly may be necessary if estimates regarding the form of the strength distribution are required. If material cost or test specimen availability limit the number of possible tests, fewer tests can be conducted to determine an indication of material properties.

8.4 *Valid Test*—A valid individual test is one which meets all the following requirements—all the testing requirements of this test method, and final fracture occurs in the uniformly-stressed gage section unless those tests fracturing outside the gage section are interpreted as interrupted tests for the purpose of censored test analyses.

9. Procedure

9.1 *Specimen Dimensions*—Determine the thickness and width of the gage section of each test specimen to within 0.02 mm. Make measurements on at least three different cross sectional planes in the gage section. To avoid damage in the critical gage section area it is recommended that these measurements be made either optically (for example, an optical comparator) or mechanically using a self-limiting (friction or ratchet mechanism) flat, anvil-type micrometer. When measuring dimensions between the woven faces of woven materials, use a self-limiting (friction or ratchet mechanism) flat anvil type micrometer having anvil cross sectional dimensions of at least 5 mm. In all cases the resolution of the instrument shall be as specified in 6.7. Exercise caution to prevent damage to the test specimen gage section. Ball-tipped or sharp anvil micrometers may be preferred when measuring test specimens

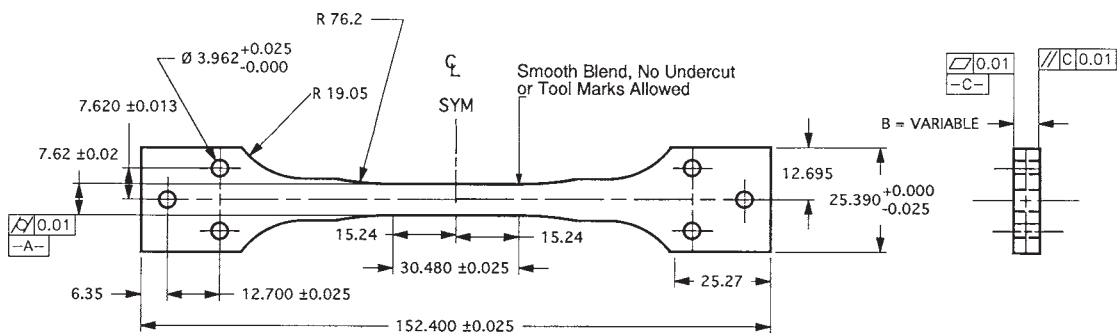

NOTE: 1) SURFACE FINISH 0.5- 1.0 µm ALL OVER EXCEPT END FACES WHICH MAY BE 1.0-2.0 µm.
2) FINAL GRIND OF GAGE SECTION TO BE LONGITUDINAL

FIG. 15 Example of a Contoured, Pin/Face-Loaded Test Specimen Geometry (4)

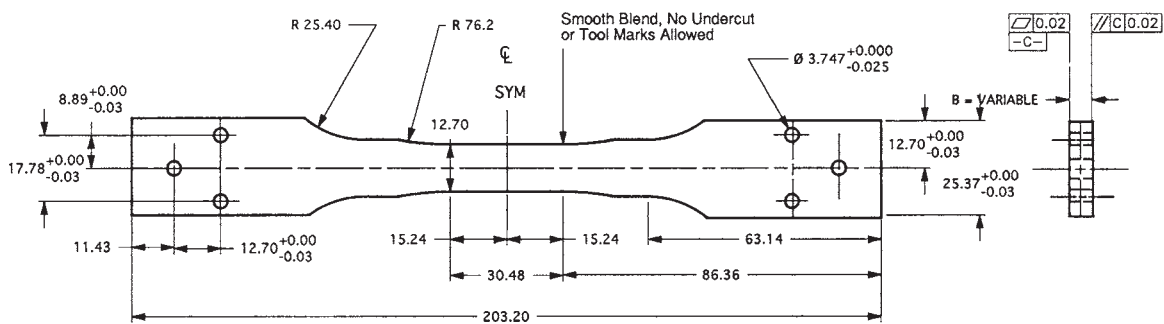

NOTE: 1) SURFACE FINISH 0.5- 1.0 µm ALL OVER EXCEPT END FACES WHICH MAY BE 1.0-2.0 µm.
2) FINAL GRIND OF GAGE SECTION TO BE LONGITUDINAL

FIG. 16 Example of a Contoured, Pin/Face-Loaded Test Specimen Geometry (5)

with rough or uneven nonwoven surfaces. Record and report the measured dimensions and locations of the measurements for use in the calculation of the tensile stress. Use the average of the multiple measurements in the stress calculations.

9.1.1 Alternatively, to avoid damage to the gage section, use the procedures described in 9.1 to make post-fracture measurements of the gage section dimensions. Note that in some cases, the fracture process can severely fragment the gage section in the immediate vicinity of the fracture thus making post-fracture measurements of dimensions difficult. In these cases, it is advisable to follow the procedures outlined in 9.1 for pretest measurements to assure reliable measurements.

9.1.2 Conduct periodic, if not 100 %, inspection/measurements of all test specimens and test specimen dimensions to ensure compliance with the drawing specifications. Generally, high resolution optical methods (for example, an optical comparator) or high resolution digital point contact methods (for example, coordinate measurement machine) are satisfactory as long as the equipment meets the specifications in 6.6. Note that the frequency of gage section fractures and

bending in the gage section are dependent on proper overall test specimen dimensions within the required tolerances.

9.1.3 In some cases it is desirable, but not required, to measure surface finish to quantify the surface condition. Such methods as contacting profilometry can be used to determine surface roughness parallel to the tensile axis. When quantified, surface roughness should be reported.

9.2 Test Modes and Rates:

9.2.1 General—Test modes and rates can have distinct and strong influences on fracture behavior of advanced ceramics even at ambient temperatures depending on test environment or condition of the test specimen. Test modes may involve force, displacement, or strain control. Recommended rates of testing are intended to be sufficiently rapid to obtain the maximum possible tensile strength at fracture of the material. However, rates other than those recommended here may be used to evaluate rate effects. In all cases the test mode and rate must be reported.

9.2.1.1 For monolithic advanced ceramics exhibiting linear elastic behavior, fracture is attributed to a weakest-link fracture

mechanism generally attributed to stress-controlled fracture from Griffith-like flaws. Therefore, a force-controlled test, with force generally related directly to tensile stress, is the preferred test mode. However, in CFCCs the non-linear stress-strain behavior characteristic of the “graceful” fracture process of these materials indicates a cumulative damage process that is strain dependent. Generally, displacement or strain controlled tests are employed in such cumulative damage or yielding deformation processes to prevent a “run away” condition (that is, rapid uncontrolled deformation and fracture) characteristic of force- or stress-controlled tests. Thus, to elucidate the potential “toughening” mechanisms under controlled fracture of the CFCC, displacement or strain control is preferred. However, for sufficiently rapid test rates, differences in the fracture process may not be noticeable and any of these test modes may be appropriate.

9.2.2 *Strain Rate*—Strain is the independent variable in non-linear analyses such as yielding. As such, strain rate is a method of controlling tests of deformation processes to avoid “runaway” conditions. For the linear elastic region of CFCCs, strain rate can be related to stress rate such that:

$$\dot{\epsilon} = \frac{d\epsilon}{dt} = \frac{\dot{\sigma}}{E} \quad (1)$$

where:

$\dot{\epsilon}$ = the strain rate in the test specimen gage section in units of s^{-1} ,

ϵ = the strain in the test specimen gage section,

t = time in units of s,

$\dot{\sigma}$ = the nominal stress rate in the test specimen gage section in units of MPa/s, and

E = the elastic modulus of the CFCC in units of MPa.

Strain-controlled tests can be accomplished using an extensometer contacting the gage section of the specimen as the primary control transducer. Strain rates on the order of 50×10^{-6} to $500 \times 10^{-6} s^{-1}$ are recommended to minimize environmental effects when testing in ambient air. Alternately, strain rates shall be selected to produce final fracture in 5 to 10 s to minimize environmental effects when testing in ambient air.

9.2.3 *Displacement Rate*—The size differences of each test specimen geometry require a different loading rate for any given stress rate. Note that as the test specimen begins to fracture, the strain rate in the gage section of the specimen will change even though the rate of motion of the cross-head remains constant. For this reason displacement rate controlled tests can give only an approximate value of the imposed strain rate. Displacement mode is defined as the control of, or free-running displacement of, the test machine cross-head. Thus, the displacement rate can be calculated as follows. Using the recommended (or desired) strain rate as detailed in 9.2.2, calculate the displacement rate for the linear elastic region of CFCCs only as:

$$\dot{\delta} = \frac{d\delta}{dt} \approx \left(\frac{1}{k_m} + \frac{1}{k_s} \right) \epsilon EA \approx \left(\frac{1}{k_m} + \frac{1}{k_s} \right) \dot{\sigma} A \quad (2)$$

where:

$\dot{\delta}$ = the displacement rate of the cross-head in units of mm/s,

δ = the cross-head displacement in units of mm,

k_m = the stiffness of the test machine and load train (including the test specimen ends and the grip interfaces) in units of N/mm,

k_s = the stiffness of the uniform gage section of the test specimen in units of N/mm,

E = the elastic modulus of the material in units of MPa, and

A = the cross sectional area of the gage section.

The cross sectional area, A , is calculated as $A = wb$ for rectangular cross sections where w is the width of the gage section in units of mm, b is the thickness of the gage section in units of mm. Note that k_s can be calculated as $k_s = AE/L$ where L is the gripped length of the specimen. The stiffness k_m can be determined as per Test Method D 3379 by measuring the load-displacement curves for various specimen lengths. The plot of k_m (slope of load-displacement curve) versus specimen length is then extrapolated to zero to find the actual machine stiffness. Alternatively, k_m can be estimated using the manufacturer’s value for frame stiffness as a starting point and decreasing this value as necessary to account for various links in the load train.

9.2.4 *Force Rate*—For materials that do not experience gross changes in cross sectional area of the gage section, force rate can be directly related to stress rate and hence to the recommended (or desired) strain rate. Note that as the test specimen begins to fracture, the strain rate in the gage section of the test specimen will change even though the rate of force application remains constant. Stress rates >35 to 50 MPa/s have been used with success (12) to minimize the influence of environmental effects and thus obtain the greatest value of ultimate tensile strength. Alternately, stress or force rates should be selected to produce final fracture in 5 to 10 s to minimize environmental effects when testing in ambient air. For the linear elastic region of CFCCs, force rate is calculated as:

$$\dot{P} = \frac{dP}{dt} = \dot{\sigma} A \approx \epsilon E \quad (3)$$

where:

\dot{P} = the required force rate in units on N/s, and

P = the applied force in units of N.

9.2.5 *Ramp Segments*—Normally, tests are conducted in a single ramp function at a single test rate from zero force to the maximum load at fracture. However, in some instances multiple ramp segments might be employed. In these cases a slow test rate is used to ramp from zero load to an intermediate load to allow time for removing “slack” from the test system. The final ramp segment of the test is conducted from the intermediate load to the maximum load at fracture at the required (desired) test rate. The type and time duration of the ramp should be reported.

9.3 Conducting the Tensile Test:

9.3.1 *Mounting the Test Specimen*—Each grip interface and specimen geometry described in Section 8 will require a unique procedure for mounting the specimen in the load train. If special components are required for each test, these should be identified and noted in the test report. Mark the specimen with an indelible marker as to top and bottom and front (side facing

the operator) in relation to the test machine. In the case of strain-gaged test specimens, orient the test specimen such that the “front” of the test specimen and a unique strain gage (for example, Strain Gage 1 designated SG1) coincide.

9.3.2 Preparations for Testing—Set the test mode and test rate on the test machine. Preload the specimen to remove the “slack” from the load train. The amount of preload will depend on the material and tensile specimen geometry, and therefore must be determined for each situation. Either mount the extensometer on the specimen gage section and zero the output, or, attach the lead wires of the strain gages to the signal conditioner and zero the outputs. (See **Note 1.**) Ready the autograph data acquisition systems for data logging.

NOTE 1—If strain gages are used to monitor bending, the strain gages should be zeroed with the specimen attached at only one end of the fixtures, that is, hanging free. This will ensure that bending due to the grip closure is factored into the measured bending.

9.3.3 Conducting the Test—Initiate the data acquisition. Initiate the test mode. After specimen fracture, disable the action of the test machine and the data collection of the data acquisition system. The breaking force should be measured within $\pm 1.0\%$ of the load range and noted for the report. Carefully remove the test specimen halves from the grip interfaces. Take care not to damage the fracture surfaces by preventing them from contact with each other or other objects. Place the test specimen halves along with other fragments from the gage section into a suitable, non-metallic container for later analysis.

9.3.4 Determine the relative humidity in accordance with Test Method **E 337**.

9.3.5 Post-Test Dimensions—A measure of the gage section cross-sectional dimensions at the fracture location can be made and reported to 0.02 mm if the gage section has not been overly fragmented by the fracture process. If an exact measure of the cross-sectional dimensions cannot be made due to fragmentation then use the average dimensions measured in **9.1**.

9.3.5.1 Measure and report the fracture location relative to the midpoint of the gage section. The convention used should be that the midpoint of the gage section is 0 mm with positive (+) measurements toward the top of the specimen as tested (and marked) and negative (–) measurements toward the bottom of the specimen as tested (and marked).

9.3.5.2 Note that results from test specimens fracturing outside the uniformly stressed gage section are not recommended for use in the direct calculation of a mean tensile strength at fracture for the entire test set. Results from test specimens fracturing outside the gage section (or outside the extensometer gage length of straight-sided test specimens) are considered anomalous and can be used only as censored tests (that is, test specimens in which a tensile stress at least equal to that calculated by Eq 7 was sustained in the uniform gage section before the test was prematurely terminated by a non-gage section fracture) as discussed in Practice **C 1239** for the determination of estimates of the strength distribution parameters. From a conservative standpoint, in completing a required statistical sample (for example, $N = 10$) for purposes of average strength, test one replacement test specimen for each test specimen that fractures outside the gage section.

9.3.5.3 Visual examination and light microscopy should be conducted to determine the mode and type of fracture (that is, brittle or fibrous). In addition, although quantitatively beyond the scope of this test method, subjective observations can be made of the length of fiber pullout, orientation of fracture plane, degree of interlaminar fracture, and other pertinent details of the fracture surface.

9.4 Fractography—Fractographic examination of each failed test specimen is recommended to characterize the fracture behavior of CFCCs. It should be clearly noted on the test report if a fractographic analysis is not performed.

10. Calculation

10.1 General—Various types of CFCC material, due to the nature of their constituents, processing routes, and prior mechanical history, may exhibit vastly different stress-strain responses as illustrated schematically in **Fig. 17(a), (b), and (c)**. Therefore, interpretation of the test results will depend on the type of response exhibited. Points corresponding to the following calculated values are shown on the appropriate diagrams.

10.2 Engineering Stress—Calculate the engineering stress as:

$$\sigma = \frac{P}{A} \quad (4)$$

where:

σ = the engineering stress in units of MPa,
 P = the applied, uniaxial tensile force in units of N , and
 A = the original cross sectional area in units of mm^2 .

The cross sectional area A is calculated as:

$$A = wb \text{ for rectangular cross sections} \quad (5)$$

where:

w = the average width of the gage section in units of mm as detailed in **9.1** and **9.1.1** and
 b = the average thickness of the gage section in units of mm as detailed in **9.1** and **9.1.1**.

10.3 Engineering Strain—Calculate the engineering strain as:

$$\epsilon = \frac{(l - l_o)}{l_o} \quad (6)$$

where:

ϵ = the engineering strain,
 l = the gage length (test specimen or extensometer gage length) at any time in units of mm, and
 l_o = the original gage length in units of mm.

For test specimens that have been strain gaged, the appropriate strain values are obtained directly without measurement of gage section elongation.

10.3.1 Note that in some cases the initial portion of the stress-strain ($\sigma - \epsilon$) curve shows a nonlinear region or “toe” followed by a linear region as shown in **Fig. 17(c)**. This toe may be an artifact of the test specimen or test conditions (for example, straightening of a warped test specimen) and thus may not represent a property of the material. The $\sigma - \epsilon$ curve can be corrected for this toe by extending the linear region of the curve to the zero-stress point on the strain axis as shown in

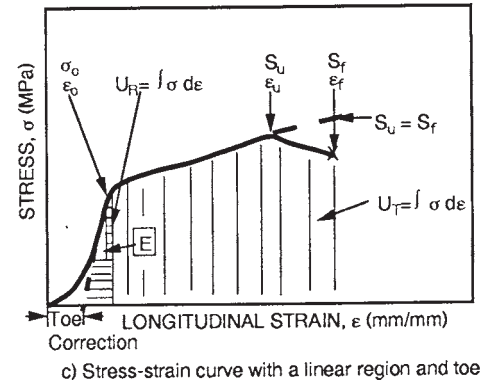
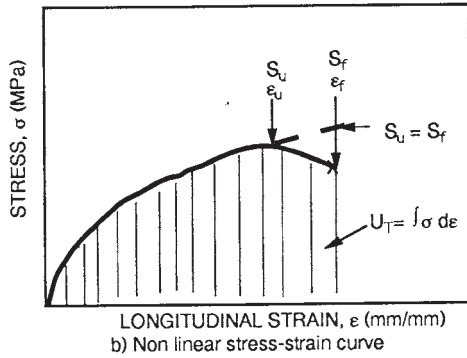
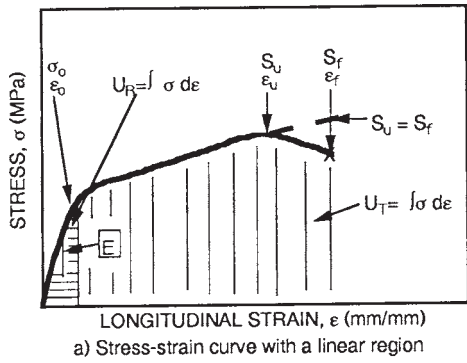

$$S_f = \frac{P_{fracture}}{A} \quad (8)$$

where:

S_f = the tensile strength in units of MPa,
 $P_{fracture}$ = the fracture force (breaking force) when the test specimen separates into two or more pieces, in units of N.

In some instances as shown by the dashed line in Fig. 17(a), (b), and (c), $S_u = S_f$.

10.7 Strain at Fracture Strength— Determine strain at fracture strength, ϵ_f , as the engineering strain corresponding to the fracture strength measured during the test. In some instances as shown by the dashed line in Fig. 17(a), (b), and (c), $\epsilon_u = \epsilon_f$.

10.8 Modulus of Elasticity—Calculate the modulus of elasticity as follows:

$$E = \frac{\Delta\sigma}{\Delta\epsilon} \quad (9)$$

where E is the modulus of elasticity, $\Delta\sigma / \Delta\epsilon$ is the slope of the $\sigma - \epsilon$ curve within the linear region as shown in Fig. 17(a) and (c). Note that the modulus of elasticity may not be defined for materials that exhibit entirely non-linear $\sigma - \epsilon$ curves as shown in Fig. 17.

10.9 Poisson's Ratio—Calculate the Poisson's ratio (if transverse strain is measured) as follows:

$$\nu = - \frac{\Delta\epsilon_T}{\Delta\epsilon_L} \quad (10)$$

where ν is Poisson's ratio,

$$\frac{\Delta\epsilon_T}{\Delta\epsilon_L}$$

is the slope of the linear region of the plot of transverse strain ϵ_T versus longitudinal strain, ϵ_L . Note that Poisson's ratio may not be defined for materials which exhibit non-linear $\sigma - \epsilon$ curves over the entire history as shown in Fig. 17(b) (although this must be verified by plotting ϵ_T versus ϵ_L to determine whether or not a linear region exists).

10.10 Proportional Limit Stress— Determine the proportional limit stress, σ_o , by one of the following methods. Note that by its definition the proportional limit stress, σ_o , may not be defined for materials that exhibit entirely non-linear $\sigma - \epsilon$ curves as shown in Fig. 17(b).

10.10.1 Offset Method—Determine σ_o by generating a line running parallel to the same part of the linear part of the $\sigma - \epsilon$ curve used to determine the modulus of elasticity in 10.8. The line so generated should be at a strain offset of 0.0005 mm/mm. The proportional limit stress is the stress level at which the offset line intersects the $\sigma - \epsilon$ curve. See Fig. 18 for a graphical illustration of this technique.

10.10.2 Extension Under Load Method— Determine σ_o by noting the stress on the $\sigma - \epsilon$ curve that corresponds to a specified strain. The specified strain may or may not be in the linear region of the $\sigma - \epsilon$ but the specified strain at which σ_o

NOTE 1—At the high strain portions of the curves two different possible behaviors are depicted: cases where stress drops prior to fracture (solid line) and cases where stress continues to increase to the point of fracture (dashed line).

FIG. 17 Schematic Diagrams of Stress-Strain Curves for CFCCs

Fig. 17(c). The intersection of this extension with the strain axis is the toe correction that is subtracted from all values of strain greater than the toe correction strain. The resulting $\sigma - \epsilon$ curve is used for all subsequent calculations.

10.4 Tensile Strength—Calculate the tensile strength as:

$$S_u = \frac{P_{max}}{A} \quad (7)$$

where:

S_u = the tensile strength in units of MPa and
 P_{max} = the maximum force in units of N.

10.5 Strain at Tensile Strength— Determine strain at tensile strength, ϵ_u , as the strain corresponding to the tensile strength measured during the test.

10.6 Fracture Strength—Calculate the fracture strength as:

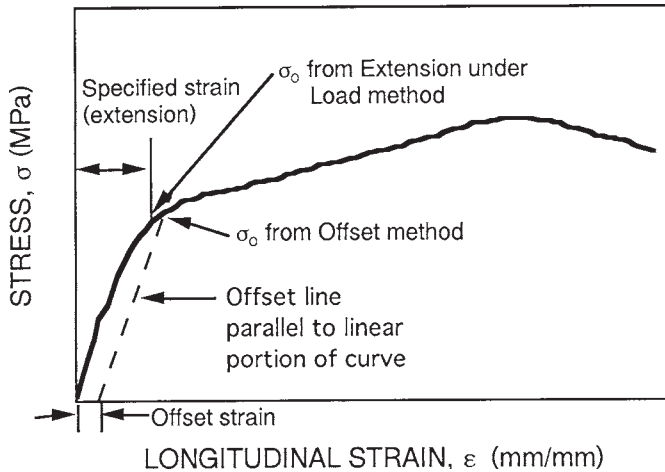

FIG. 18 Schematic Diagram of Methods for Determining Proportional Limit Stress

is determined must be constant for all tests in a set with the specified strain reported. See Fig. 18 for a graphical illustration of this technique.

10.10.3 *Deviation From Linearity Method*— Determine σ_o by noting the stress σ_i , on the $\sigma - \epsilon$ curve at which there is a specified percent deviation (for example, %dev = 10) from the stress calculated from the elastic relation, $\sigma = E\epsilon_i$ such that:

$$\%dev = 100 \left[\frac{(E\epsilon_i) - \sigma_i}{\sigma_i} \right] \quad (11)$$

where:

- σ_i and ϵ_i = the i-th stress and corresponding strain, respectively, on the $\sigma - \epsilon$ curve, and
- E = the modulus of elasticity.

The proportional limit stress is determined, such that $\sigma_o = \sigma_i$ when %dev first equals or exceeds the specified value when evaluating increasing σ_i and ϵ_i starting from zero.

10.11 *Strain at Proportional Limit Stress*—Determine strain at proportional limit stress, ϵ_o , as the strain corresponding to proportional limit stress determined for the test.

10.12 *Modulus of Resilience*—Calculate the modulus of resilience as the area under the linear part of the $\sigma - \epsilon$ curve or alternatively estimated as:

$$U_R = \int_0^{\epsilon_o} \sigma d\epsilon \approx \frac{1}{2} \sigma_o \epsilon_o \quad (12)$$

where:

- U_R = the modulus of resilience in J/m^3 , and σ_o and ϵ_o as used in Eq 12 have units of Pa (that is, N/m^2) and mm/mm , respectively.

10.13 *Modulus of Toughness*—Calculate the modulus of toughness as the area under the entire $\sigma - \epsilon$ curve or alternatively estimated as:

$$U_T = \int_0^{\epsilon_f} \sigma d\epsilon \approx \frac{\sigma_o + S_u}{2} \epsilon_f \quad (13)$$

where U_T is the modulus of toughness in J/m^3 , and σ_o and S_u as used in Eq 13 have units of Pa (that is, N/m^2) and ϵ_o has

units of mm/mm .

Note that U_T can be estimated as follows for materials for which σ_o is not calculated and that have a $\sigma - \epsilon$ curve that can be assumed to be a parabola:

$$U_T = \int_0^{\epsilon_f} \sigma d\epsilon \approx \frac{2}{3} S_u \epsilon_f \quad (14)$$

10.13.1 Note that the modulus of toughness can also be referred to as the cumulative damage energy and as such is regarded as an indication of the ability of the material to sustain damage rather than as a material property. Fracture mechanics methods for the characterization of CFCCs have not been developed. The determination of the modulus of toughness as provided in this test method for the characterization of the cumulative damage process in CFCCs may become obsolete when fracture mechanics methods for CFCCs become available.

10.14 *Mean, Standard Deviation, and Coefficient of Variation*—For each series of tests the mean, standard deviation, and coefficient of variation for each measured value can be calculated as follows:

$$mean = \bar{X} = \frac{\sum_{i=1}^n X_i}{n} \quad (15)$$

$$standard\ deviation = s.d. = \sqrt{\frac{\sum_{i=1}^n (X_i - \bar{X})^2}{n - 1}} \quad (16)$$

$$coefficient\ of\ variation = V = \frac{100(s.d.)}{\bar{X}} \quad (17)$$

X = the measured value and n = the number of valid tests.

11. Report

11.1 *Test Set*—Report the following information for the test set. Any significant deviations from the procedures and requirements of this test method should be noted in the report:

11.1.1 Date and location of testing,

11.1.2 Tensile test specimen geometry used (include engineering drawing). For end-tabbed specimens, a drawing of the tab as well as the tab material and adhesive used should be specified,

11.1.3 Type and configuration of the test machine (include drawing or sketch if necessary). If a commercial test machine was used, the manufacturer and model number are sufficient for describing the test machine,

11.1.4 Type, configuration, and resolution of strain measurement equipment used (include drawing or sketch if necessary). If a commercial extensometer or strain gages were used, the manufacturer and model number are sufficient for describing the strain measurement equipment,

11.1.5 Type and configuration of grip interface used (include drawing or sketch if necessary). If a commercial grip interface was used, the manufacturer and model number are sufficient for describing the grip interface,

11.1.6 Type and configuration of load train couplers (include drawing or sketch if necessary). If a commercial load

train coupler was used, the manufacturer and model number are sufficient for describing the coupler,

11.1.7 Number (*n*) of specimens tested validity (for example, fracture in the gage section). In addition, report total of number of specimens tested (*n_T*) to provide an indication of the expected success rate of the particular specimen geometry and test apparatus.

11.1.8 All relevant material data including vintage data or billet identification data. (Did all specimens come from one billet or processing run?) As a minimum, the date the material was manufactured must be reported. For commercial materials, the commercial designation must be reported. At a minimum include a short description of reinforcement (type, layout, etc.), fiber volume fraction, and bulk density,

11.1.8.1 For non-commercial materials, the major constituents and proportions should be reported as well as the primary processing route including green state and consolidation routes. Also report fiber volume fraction, matrix porosity, and bulk density. The reinforcement type, properties and reinforcement architecture should be fully described to include fiber properties (composition, diameter, source, lot number and any measured/specified properties), interface coatings (composition, thickness, morphology, source, and method of manufacture) and the reinforcement architecture (yard type/count, thread count, weave, ply count, fiber areal weight, stacking sequence, ply orientations, etc.),

11.1.9 Description of the method of specimen preparation including all stages of machining,

11.1.10 Heat treatments, coatings, or pre-test exposures, if any applied either to the as-processed material or to the as-fabricated specimen,

11.1.11 Test environment including relative humidity (see Test Method E 337), ambient temperature, and atmosphere (for example, ambient air, dry nitrogen, silicone oil, etc.),

11.1.12 Test mode (load, displacement, or strain control) and actual test rate (load rate, displacement rate, or strain rate). Calculated strain rate should also be reported, if appropriate, in units of s⁻¹,

11.1.13 Percent bending and corresponding average strain in the specimen recorded during the verification as measured at the beginning and end of the test series,

11.1.14 Mean, standard deviation, and coefficient of variation for each test series the following measured properties:

11.1.14.1 Tensile strength, *S_u*,

11.1.14.2 Strain at tensile strength, *ε_u*,

11.1.14.3 Fracture strength, *S_f*,

11.1.14.4 Strain at fracture strength, *ε_f*,

11.1.14.5 Modulus of elasticity, *E* (if applicable),

11.1.14.6 Poisson's ratio, *ν* (if applicable),

11.1.14.7 Proportional limit stress, *σ_o* (if applicable) and method of determination,

11.1.14.8 Strain at proportional limit stress, *ε_o* (if applicable),

11.1.14.9 Modulus of resilience, *U_R* (if applicable), and

11.1.14.10 Modulus of toughness, *U_T* (if applicable).

11.2 *Individual Specimens*—The report should include the following information for each specimen tested. Any significant deviations from the procedures and requirements of this test method should be noted in the report:

11.2.1 Pertinent overall specimen dimensions, if measured, such as total length, length of gage section, gripped section dimensions, etc. in units of mm,

11.2.2 Average surface roughness, if measured, of gage section measured in the longitudinal direction in units of μm,

11.2.3 Average cross sectional dimensions, in units of mm,

11.2.4 Plot of the entire stress-strain curve,

11.2.5 Tensile strength, *S_u*,

11.2.6 Strain at tensile strength, *ε_u*,

11.2.7 Fracture strength, *S_f*,

11.2.8 Strain at fracture strength, *ε_f*,

11.2.9 Modulus of elasticity, *E* (if applicable),

11.2.10 Poisson's ratio, *ν* (if applicable),

11.2.11 Proportional limit stress, *σ_o* (if applicable) and method of determination,

11.2.12 Strain at proportional limit stress, *ε_o* (if applicable),

11.2.13 Modulus of resilience, *U_R* (if applicable),

11.2.14 Modulus of toughness, *U_T* (if applicable),

11.2.15 Fracture location relative to the gage section midpoint in units of mm (+ is toward the top of the specimen as marked and – is toward the bottom of the specimen as marked with 0 being the gage section midpoint), and

11.2.16 Appearance of specimen after fracture as suggested in 9.3.5.3.

12. Precision and Bias

12.1 The tensile behavior of a ceramic composite is not deterministic, but varies from one test specimen to another. Sources of this variability are inherent variations in ceramic composites fabricated with ceramic fiber reinforcements and ceramic matrices. Variables include property variation of

TABLE 1 Tensile Test Results and Repeatability / Reproducibility Analysis^A Results for Trademark Sylramic[®] S200 Ceramic Composite Tested per Test Method C 1275 (Ten test specimens tested in each of nine laboratories)

	Modulus of Elasticity	Proportional Limit Stress ^B	Ultimate Tensile Strength	Strain at Fracture
Mean among the nine laboratories	92.9 GPa	84.5 MPa	251 MPa	0.004280 mm/mm
"Repeatability"— Mean of the Coefficient Of Variation of the nine laboratories	4.6 %	3.4 %	7.2 %	9.3 %
"Reproducibility"— Coefficient Of Variation between the nine laboratories	5.0 %	4.1 %	7.2 %	9.2 %
95% Repeatability Limit (within Laboratory) 2.8 CV _r % ^A	12.9 %	9.5 %	20.2 %	26.0 %
95% Reproducibility Limit (between Laboratories) 2.8 CV _R % ^A	15.0 %	11.5 %	20.2 %	25.8 %

^ACalculated in accordance with Practice E 691 and reported in accordance with Practice E 177.

^BProportional limit stress determined using the extension under load method at 0.001 mm/mm.

fibers, matrix and interphase, as well as variations in the architecture, volume fraction of reinforcement and bulk density of the composite. Such variations can occur spatially within a given test specimen, as well as between different test specimens.

12.2 A multiple laboratory round-robin test (13) was conducted in 1998 to measure the precision of tensile properties in accordance with Test Method C 1275 for a commercially-available continuous fiber-reinforced ceramic composite.⁴ Although the reporting of nine different tensile parameters is required for Test Method C 1275, for the purposes of this precision and bias statement, repeatability and reproducibility were assessed for the representative properties of modulus of elasticity, proportional limit stress (extension under load method at 0.001 mm/mm), ultimate tensile strength and strain at fracture 90 randomly divided test specimens tested in sets of ten by nine different laboratories. Bias was not evaluated, because there is no commonly recognized standard reference material for continuous fiber-reinforced ceramic composites.

12.2.1 Tensile test specimens (150 mm long × 10 mm wide with reduced gage sections of 35 mm long and 8 mm wide) were diamond-grit cut from three panels (nominally 3 mm thick) of a commercial Trademark Sylramic⁴ S200 ceramic composite. The panels were fabricated with eight plies of ceramic grade (CG)-Trademark Nicalon⁵ fabric (8-Harness Satin) in a silicon-carbonitride matrix (based on a preceramic polymer) with a silicon nitride powder filler. The ply architec-

ture was a symmetric 0/90 lay-up (0/90/0/90/90/0/90/0). The NicalonSM tows had a proprietary boron nitride interphase coating. The as-fabricated tensile test specimens had a nominal density of 2200 kg/m³, a nominal fiber volume fraction of 45 % and an average open porosity of 2.7 %.

12.2.2 Round robin participants were required to perform tensile tests in accordance with Test Method C 1275. All tensile test specimens were end tabbed by participants using tabs and adhesive supplied as part of the round robin. Tests were conducted under displacement control at 0.02 mm/s. Strain was measured over a 25-mm gage length.

12.2.3 A statistical analysis of the tensile test results was performed using the procedures and criteria of Practice E 691. All the results for elastic modulus, proportional limit stress, ultimate tensile strength, and strain at fracture were determined to be valid and applicable. Repeatability and reproducibility results are contained in Table 1.

12.3 *Sources of Variability*—The test results were analyzed for variability in experimental procedures between laboratories and for variability in material thickness, density, and porosity among the test specimens, as well as, differences between test specimens cut from the three different panels. Possible statistically significant effects were indicated for type of loading mechanism and extensometer gage length. Definite statistically significant effects were indicated for panel of origin for variability in ultimate tensile strength and strain at fracture (13).

13. Keywords

13.1 ceramic matrix composite; CFCC continuous fiber composite; tensile test

⁴ Sylramic is a registered trademark of S200, Dow Corning, Inc., Midland, MI in November 1997 (as of July 1999, Engineered Ceramics, Inc., San Diego, CA.

⁵ Nicalon is a registered trademark of Nippon Carbon Co., Ltd.

APPENDIX

(Nonmandatory Information)

X1. VERIFICATION OF LOAD TRAIN ALIGNMENT

X1.1 *Purpose of Verification*—The purpose of this verification procedure is to demonstrate that the grip interface and load train couplers can be used by the test operator in such a way as to consistently meet the limit on percent bending as specified in 6.5. Thus, this verification procedure should involve no more care in setup than will be used in the routine testing of the actual tensile specimen. The bending under tensile load should be measured using verification (or actual) specimens of exactly the same design as that to be used for the tensile tests. For the verification purposes, strain gages should be applied as shown in Fig. X1.1. Verification measurements should be conducted at the beginning and end of a series of tests with a measurement at the midpoint of the series recommended, whenever the grip interfaces and load train couplers are installed on a different test machine, whenever a different operator is conducting a series of tests, damage or

misalignment is suspected.

X1.2 *Verification Specimen*—The specimen used for verification must be machined very carefully with attention to all tolerances and concentricity requirements. Ideally the verification specimen should be of identical material to that being tested. However, in the case of CFCCs the type of reinforcement or degree of residual porosity may complicate the consistent and accurate measurement of strain. Therefore, it is recommended that an alternate material (isotropic, homogeneous, continuous) should be used with elastic modulus, elastic strain capability, and hardness similar to the test material. The specimen should be carefully inspected with an optical comparator before strain gages are attached to ensure that these requirements are met. After the strain gages are applied it will no longer be possible to meaningfully inspect the specimen, so

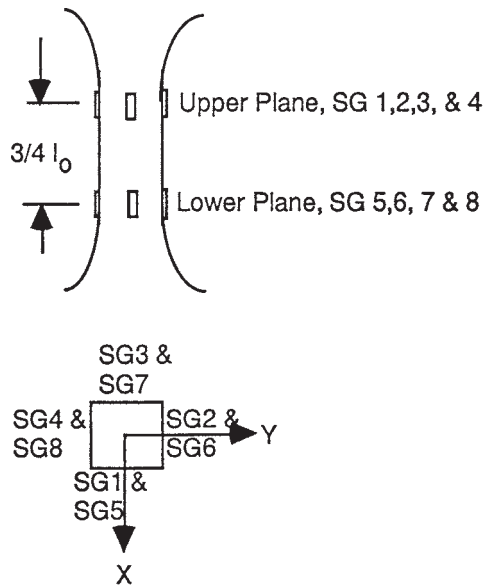

FIG. X1.1 Illustration of Strain Gage Placement on Gage Section Planes and Strain Gage Numbering

care should be exercised in handling and using it.

X1.2.1 For simplicity, a minimum of eight foil resistance strain gages should be mounted on the verification specimen as shown in Fig. X1.1. Note that the strain gage planes should be separated by $\sim 3/4 I_o$ where I_o is the length of the reduced or designated gage section. In addition, care must be taken to select the strain gage planes to be symmetrical about the longitudinal midpoint of the gage section to avoid placing the strain gages closer than one strain gage length from geometrical features, such as the transition radius from the gage section. Strain gages on dummy specimens composed of isotropic homogeneous materials should be as narrow as possible to minimize strain averaging. Strain gages having active widths of 0.25 to 0.5 mm and active lengths of 1.0 to 2.5 mm are commercially available and are suitable for this purpose. Otherwise, strain gages on test specimens composed of CFCC materials should be of the size recommended in 6.4.2. Four strain gages, equally spaced (90° apart) around the circumference of the gage section (that is, one strain gage on each face), should be mounted at each of two planes at either end of the gage section. These planes should be symmetrically located about the longitudinal midpoint of the gage section. Note that care should be taken to avoid placing the strain gages too near geometric transitions in the gage section, which can cause strain concentrations and inaccurate measures of the strain in the uniform gage section.

X1.3 Verification Procedure—Procedures for verifying alignment are described in detail in Practice E 1012. However, salient points for square cross sections are described here for emphasis. For rectangular cross sections, especially when the thickness is too thin to strain gage all four sides, Practice E 1012 should be consulted for specific details.

X1.3.1 Connect the lead wires of the strain gages to the conditioning equipment and allow the strain gages to equilibrate under power for at least 30 min prior to conducting the

verification tests. This will minimize drift during actual conduct of the verifications.

X1.3.2 Mount the top of the specimen in the grip interface.

X1.3.3 Zero the strain gages before mounting the bottom of the specimen in the grip interface. This will allow any bending due to the grips to be recorded.

X1.3.4 Mount the bottom of the specimen in the grip interface.

X1.3.5 Apply a sufficient load to the specimen to achieve a mean strain equal to either one half the anticipated strain at the onset of the cumulative fracture process (for example, matrix cracking stress) in the test material or a strain of 0.0005 (that is, 500 microstrain) whichever is greater. Note that it is desirable to record the strain (and hence percent bending) as functions of the applied load to monitor any self alignment of the load train.

X1.3.6 Calculate percent bending as follows referring to Fig. X1.1 for the strain gage numbers. Percent bending at the upper plane of the gage section is calculated as follows:

$$PB_{upper} = \frac{\epsilon_b}{\epsilon_o} 100 \quad (X1.1)$$

$$\epsilon_b = \left[\left(\frac{\epsilon_1 - \epsilon_3}{2} \right)^2 + \left(\frac{\epsilon_2 - \epsilon_4}{2} \right)^2 \right]^{1/2} \quad (X1.2)$$

$$\epsilon_o = \frac{\epsilon_1 + \epsilon_2 + \epsilon_3 + \epsilon_4}{4} \quad (X1.3)$$

where ϵ_1 , ϵ_2 , ϵ_3 and ϵ_4 are strain readings for strain gages located at the upper plane of the gage section. Note that strain gage readings are in units of strain and compressive strains are negative.

X1.3.7 The direction of the maximum bending strain on the upper plane is determined as follows:

$$\theta_{upper} =$$

where θ_{upper} is measured from the strain gage with the greatest reading in the direction of the strain gage with the second greatest reading where counter clockwise is positive.

X1.3.8 Percent bending at the lower plane of the gage section is calculated as follows:

$$PB_{lower} = \frac{\epsilon_b}{\epsilon_o} 100$$

$$\epsilon_b = \left[\left(\frac{\epsilon_5 - \epsilon_6}{2} \right)^2 + \left(\frac{\epsilon_7 - \epsilon_8}{2} \right)^2 \right]^{1/2}$$

$$\epsilon_o = \frac{\epsilon_5 + \epsilon_6 + \epsilon_7 + \epsilon_8}{4}$$

where ϵ_5 , ϵ_6 , ϵ_7 and ϵ_8 are strain readings for strain gages located at the lower plane of the gage section. Note that strain gage readings are in units of strain and compressive strains are negative.

X1.3.9 The direction of the maximum bending strain on the lower plane is determined as follows:

$$\theta_{lower} = \arctan \left[\frac{\epsilon_{(\text{next greatest of } 5, 6, 7, 8)} - \epsilon_0}{\epsilon_{(\text{greatest of } 5, 6, 7, 8)} - \epsilon_0} \right]$$

where θ_{lower} is measured from the strain gage with the greatest reading in the direction of the strain gage with the second greatest reading where counter clockwise is positive.

X1.3.10 Note that for the following comparisons, θ_{upper} and θ_{lower} may be adjusted to reference the same point on the circumference. Since strain gages 1 and 5 fall on the same longitudinal line around the circumference, for consistency these may be used as reference points for θ_{upper} and θ_{lower} respectively. For example, on the upper plane, if strain gage 2 is the greatest measured strain with strain gage 3 being the next greatest measured strain then the direction of the maximum bending strain with reference to strain gage 1 is $\theta_{upper} + 90^\circ$ in counterclockwise direction (that is, from strain gage 1 to 2). For uniform bending across the gage section with the specimen assuming a C-shape, $PB_{upper} \approx PB_{lower}$ and $|\theta_{upper} - \theta_{lower}| \approx 0^\circ$. C-shape bending reflects angular misalignment of the grips. For non-uniform bending across the gage section with the specimen assuming an S-shape, PB_{upper} may or may not be equal to PB_{lower} and $|\theta_{upper} - \theta_{lower}| \approx 180^\circ$. S-shape bending reflects eccentric misalignment of the grip centerlines. These general tendencies are shown in Fig. X1.2. Combinations of C and S shapes may exist where $>$ and $|\theta_{upper} - \theta_{lower}|$ is some angle between 0 and 180° . In these cases the S-shape should first be eliminated by adjusting the concentricity of the grips such that the longitudinally aligned strain gages indicate approximately the same values (for

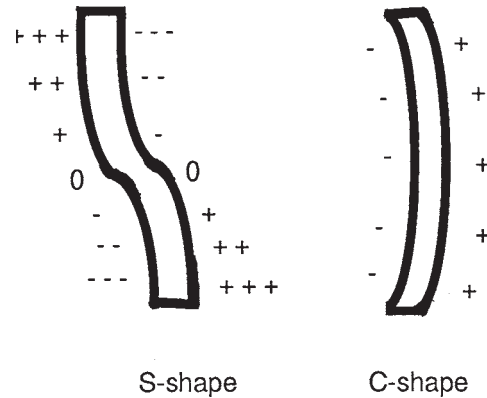



FIG. X1.2 S-Shape and C-Shape Bending of Tensile Specimen

example, $\epsilon_1 \approx \epsilon_5$, $\epsilon_2 \approx \epsilon_6$, etc.). More detailed discussions regarding bending and alignment are contained in (13).

X1.3.11 The effect of the specimen warpage can be checked by rotating the specimen 180° about its longitudinal axis and performing the bending checks again. If similar results are obtained at each rotation then the degree of alignment can be considered representative of the load train and not indicative of the specimen. If load train alignment is within the specifications of 6.5, the maximum percent bending should be recorded and the tensile tests may be conducted. If the load train alignment is outside the specifications of 6.5 then the load train must be aligned or adjusted according to the specific procedures unique to the individual testing setup. This verification procedure must then be repeated to confirm the achieved alignment.

REFERENCES

- (1) Hartman, G. A., Zawada, L. P., and Russ, S. M., "Techniques for Elevated Temperature Testing of Advanced Ceramic Composite Materials," *Proceedings of the Fifth Annual Hostile Environment and High Temperature Measurement Conference*, Society for Experimental Mechanics, Bethel, Connecticut, 1988, pp. 31–38.
- (2) Lewis, D., III, "Tensile Testing of Ceramics and Ceramic-Matrix Composites," *Tensile Testing*, ASM International, Materials Park, Ohio, 1992, pp. 147–181.
- (3) Holmes, J. W., "A Technique for Elevated Temperature Creep and Tensile Fatigue Testing of Fiber-Reinforced Ceramics," *J. Compos. Mater.*, 26[6] 1992, pp. 915–932.
- (4) Barnett, T. R., and Starett, H. S., "Room and Elevated Temperature Mechanical and Thermal Properties of Corning Nicalon/CAS" *WRDC-TR-90-4131*, Wright Research and Development Center, Wright Patterson Air Force Base, Ohio, 1992.
- (5) Bartlett, M. L., "Expectations and Elevated Temperature Testing of Advanced Materials Used for the Development of NASP," *Proceedings of International Symposium on Ultra-High Temperature Materials*, Ube, Japan, 1991.
- (6) Amaral, J. E., and Pollock, C. N., "Machine Design Requirements for Uniaxial Testing of Ceramic Materials," *Mechanical Testing of Engineering Ceramics at High Temperatures*, B. F. Dyson, R. D. Lohr, and R. Morrell, eds., 1989, pp. 51–68.
- (7) Mosiman, L. G., Wallenfelt, T. L., and Larsen, C. G., "Tension/Compression Grips for Monolithic Ceramics and Ceramic Matrix Composites," *Ceramic Engineering and Science Proceedings*, 12(7–8), 1991.
- (8) Liu, K. C., and Brinkman, C. R., "Tensile Cyclic Fatigue of Structural Ceramics," *Proceedings of the 23rd Automotive Technology Development Contractors' Coordination Meeting*, P-165, SAE Warrendale, PA, 1986, pp. 279–284.
- (9) Mejia, L. C., "High Temperature Tensile Testing of Advanced Ceramics," *Ceramic Engineering and Science Proceedings*, 10 (7–8), 1989, pp. 668–681.
- (10) Jenkins, M. G., Ferber, M. K., Martin, R. L., Jenkins, V. T., Tennery, V. J., "Study and Analysis of the Stress State in a Ceramic, Button-Head, Tensile Specimen," Oak Ridge National Laboratory Technical Memorandum, *ORNL/TM 11767*, September 1991.
- (11) Wortham, D. W., "Flat Tensile Specimen Design for Advanced Composites," *NASA CR-185261*, November 1990.
- (12) Shuler, S. F., and Holmes, J. W., Research Memorandum No. 102, September, 1990, "Influence of Loading Rate on the Monotonic Tensile Behavior of Fiber Reinforced Ceramics." Available through: Ceramic Composites Research Laboratory, Dept. of Mechanical Engineering and Applied Mechanics, 1065 GGBL, The University of Michigan, Ann Arbor, MI 48109-2125.
- (13) Jenkins, M. G. and Zawada, L. P., "Detailed Study of the Tensile Behavior of a Two-Dimensionally Woven Nicalon[®]/Sylramic[®] Ceramic Matrix Composite," *Environmental, Mechanical, and Thermal Testing and Performance of Ceramic Composites*, ASTM STP 1392, ASTM, 2000, p. XX.

 C 1275 – 00 (2005)^{€1}

ASTM International takes no position respecting the validity of any patent rights asserted in connection with any item mentioned in this standard. Users of this standard are expressly advised that determination of the validity of any such patent rights, and the risk of infringement of such rights, are entirely their own responsibility.

This standard is subject to revision at any time by the responsible technical committee and must be reviewed every five years and if not revised, either reapproved or withdrawn. Your comments are invited either for revision of this standard or for additional standards and should be addressed to ASTM International Headquarters. Your comments will receive careful consideration at a meeting of the responsible technical committee, which you may attend. If you feel that your comments have not received a fair hearing you should make your views known to the ASTM Committee on Standards, at the address shown below.

This standard is copyrighted by ASTM International, 100 Barr Harbor Drive, PO Box C700, West Conshohocken, PA 19428-2959, United States. Individual reprints (single or multiple copies) of this standard may be obtained by contacting ASTM at the above address or at 610-832-9585 (phone), 610-832-9555 (fax), or service@astm.org (e-mail); or through the ASTM website (www.astm.org).