



Standard Test Methods for Cold Crushing Strength and Modulus of Rupture of Refractories¹

This standard is issued under the fixed designation C 133; the number immediately following the designation indicates the year of original adoption or, in the case of revision, the year of last revision. A number in parentheses indicates the year of last reapproval. A superscript epsilon (ϵ) indicates an editorial change since the last revision or reapproval.

This standard has been approved for use by agencies of the Department of Defense.

1. Scope

1.1 These test methods cover the determination of the cold crushing strength and the modulus of rupture (MOR) of dried or fired refractory shapes of all types.

1.2 The test methods appear in the following sections:

Test Method	Sections
Cold Crushing Strength	4 to 9
Modulus of Rupture	10 to 15

1.3 The values stated in inch-pound units are to be regarded as standard. The values given in parentheses are mathematical conversions to SI units that are provided for information only and are not considered standard.

1.4 *This standard does not purport to address all of the safety concerns, if any, associated with its use. It is the responsibility of the user of this standard to establish appropriate safety and health practices and determine the applicability of regulatory limitations prior to use.*

2. Referenced Documents

2.1 *ASTM Standards:*²

C 862 Practice for Preparing Refractory Concrete Specimens by Casting

C 1054 Practice for Pressing and Drying Refractory Plastic and Ramming Mix Specimens

E 4 Practices for Force Verification of Testing Machines

¹ These test methods are under the jurisdiction of ASTM Committee C08 on Refractories and are the direct responsibility of Subcommittee C08.01 on Strength. Current edition approved Aug. 1, 2008. Published September 2008. Originally approved in 1937. Last previous edition approved in 2003 as C 133 – 97 (2003).

² For referenced ASTM standards, visit the ASTM website, www.astm.org, or contact ASTM Customer Service at service@astm.org. For *Annual Book of ASTM Standards* volume information, refer to the standard's Document Summary page on the ASTM website.

3. Significance and Use

3.1 The cold strength of a refractory material is an indication of its suitability for use in refractory construction. (It is not a measure of performance at elevated temperatures.)

3.2 These test methods are for determining the room temperature flexural strength in 3-point bending (cold modulus of rupture) or compressive strength (cold crushing strength), or both, for all refractory products.

3.3 Considerable care must be used to compare the results of different determinations of the cold crushing strength or modulus of rupture. The specimen size and shape, the nature of the specimen faces (that is, as-formed, sawed, or ground), the orientation of those faces during testing, the loading geometry, and the rate of load application, may all significantly affect the numerical results obtained. Comparisons of the results between different determinations should not be made if one or more of these parameters differ between the two determinations.

3.4 The relative ratio of the largest grain size to the smallest specimen dimension may significantly affect the numerical results. For example, smaller, cut specimens containing large grains may present different results than the bricks from which they were cut. Under no circumstances should 6- by 1- by 1-in. (152- by 25- by 25-mm) specimens be prepared and tested for materials containing grains with a maximum grain dimension exceeding 0.25 in. (6.4 mm).

3.5 This test method is useful for research and development, engineering application and design, manufacturing process control, and for developing purchasing specifications.

COLD CRUSHING STRENGTH

4. Apparatus

4.1 *Testing Machine*—Any form of standard mechanical or hydraulic compression testing machine conforming to the requirements of Practices **E 4** may be used.

NOTE 1—For low-strength materials (such as insulating bricks or castables), a sensitivity of 20 lbf (67 kN) or less is required. The use of a hydraulic testing machine is also preferred over the mechanical type for these materials.

4.2 *Spherical Bearing Block*—The plane surface of the spherical bearing block (see Fig. 1) shall have an area which is equal to or greater than the cross section of the test specimen.

5. Test Specimens

5.1 *Brick and Shapes (bulk density greater than 100 lb/ft³ (1.60 g/cm³))*—The test specimens shall be 2-in. (51-mm) cubes or cylinders, 2 in. (51 mm) in diameter by 2 in. (51 mm) high. The height should be parallel to the original direction of pressing of the brick or shape. In the case of special shapes, only one specimen shall be cut from a single shape and as many of the original surfaces as possible shall be preserved. In preparing specimens from irregular or large refractory shapes, any method involving the use of abrasives, such as a high-speed abrasion wheel, core drill, or rubbing bed, that will produce a specimen with approximately plane and parallel sides without weakening the structure of the specimen may be used.

5.2 *Insulating Brick or Shapes (typical bulk density of 100 lb/ft³ (1.60 g/cm³), or greater than 45 % total porosity, or both)*—The test specimens shall be 4½ by 4½ by 2½ or 3 in. (114 by 114 by 64 or 76 mm), each taken from a different brick. It is permissible to prepare these specimens from the half-brick resulting from the modulus of rupture test (see Sections 10-15). The selected compression test section shall be free of cracks, chipped surfaces, and other obvious defects. The test surfaces shall be approximately parallel planes.

5.3 *Castable Refractories*—The test specimens shall be 2- by 2- by 2-in. (51- by 51- by 51-mm) cubes or cylinders 2 in. (51 mm) in diameter by 2 in. (51 mm) high, prepared by casting or gunning. It is permissible to prepare one specimen from each 9- by 2- by 2-in. (230- by 51- by 51-mm) bar after the modulus of rupture test (see Sections 10-15). The selected compression test section shall be free of cracks, chipped surfaces, and other obvious defects. The loaded surfaces shall be approximately parallel planes. All samples must be dried at

220 to 230°F (105 to 110°C) for 18 h (overnight). Upon removal from the oven, allow the sample to cool naturally until cool to the touch. Complete testing within 2 h of removal from the drying oven. (See Practices C 862 and C 1054.)

6. Procedure

6.1 At least five specimens from an equivalent number of refractory shapes compose a sample.

NOTE 2—For relatively weak specimens like insulating castables or insulating firebricks, a minimum sample size of ten specimens is preferred.

6.2 *Brick and Shapes*—Place a cellulose fiber wall board (for example, Masonite³) 0.25 in. (6.4 mm) in thickness and extending 0.5 in. (12.7 mm) or more beyond the edges of the loaded faces of the specimen. Apply the load parallel to the direction in which the brick was originally pressed.

6.3 *Regular and High Strength Castables*—Place a cellulose fiber wall board 0.25 in. (6.4 mm) in thickness and extending 0.5 in. (12.7 mm) or more beyond the edges of the loaded faces of the specimen. Apply the load on the 2- by 2-in. (51- by 51-mm) or 2-in. (51-mm) diameter face and perpendicular to the depth of the specimen as originally cast or gunned.

6.4 *Insulating Brick or Shapes*—Apply the load directly to the 4½- by 4½-in. (114- by 114-mm) surface of the test specimen.

6.5 *Insulating Castables (typical bulk density of 100 lb/ft³ (1.60 g/cm³), or greater than 45 % total porosity, or both)*—Apply the load directly to the 2- by 2-in. (51- by 51-mm) face and perpendicular to the depth of the specimen as originally cast or gunned.

6.6 Use the bearing block on top of the test specimen, and position it so that the center of the sphere is in alignment with the vertical axis of the specimen (see Fig. 1). Keep the spherical bearing block thoroughly lubricated to ensure accurate adjustment which may be made by hand under a small initial load for each specimen.

NOTE 3—The spherical bearing block may not be necessary on test machines having mechanical linkages which ensure that the stress applied is colinear with the axis of the specimen.

6.7 For *dense* refractories with sufficient strength to require greater than about 3 min per test, initial loading to one-half of the anticipated failure load may be accomplished at any convenient rate exceeding the specified rate. Subsequently, each specimen shall be crushed with a compressive load applied at the standard rates specified in Table 1. The rates shall not vary by more than ±10 % of the specified rate for the type of refractory being tested.

6.8 When using a mechanical testing machine, keep the balance beam in a constantly floating position.

6.9 Specimens are loaded, as specified, to failure. Failure is defined as the collapse of the specimen (failure to support the load), or the reduction of the specimen height to 90 % of its original value. The maximum applied load is recorded.

7. Calculation

7.1 Calculate the cold crushing strength using Eq 1:

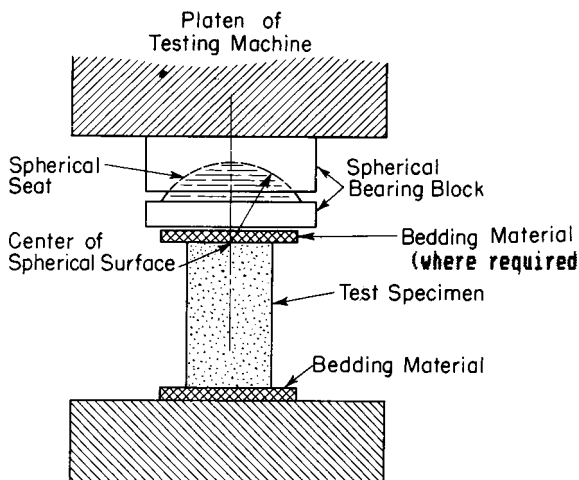

FIG. 1 Recommended Design for Crushing Test Assembly, Including Bearing Block

³ Masonite has been found satisfactory for this purpose.

TABLE 1 Standard Loading Rates for Cold Crushing Strength

Refractory Type	Size, in. (mm)	Loaded Cross Section, in. (mm)	Loaded Area, in. ² (mm ²)	Stress Rate, lbf/in. ² /min (MPa/min)	Loading Rate, lbf/min (kN/min)	Strain Rate, ^A in./min (mm/min)
<i>Refractory Brick and Shapes</i>						
Density >100 lb/ft ³ (>1.60 gm/cm ³), or <45 % true porosity, or both	2 × 2 × 2 (51 × 51 × 51)	2 × 2 (51 × 51)	4 (2601)	1750 ^B (12)	7000 ^B (31.2)	0.05 ^B (1.3)
(Includes regular or high strength castables and fired plastic or rammed refractories)	2 diameter × 2 (51 diameter × 51)	2, diameter (51, diameter)	3.14 (2027)	1750 ^B (12)	5500 ^B (24.3)	0.05 ^B (1.3)
<i>Insulating Refractories</i>						
Density <100 lb/ft ³ (<1.60 gm/cm ³), or >45 % true porosity, or both	4.5 × 4.5 × 2.5 ^{C,D} (114 × 114 × 64)	4.5 × 4.5 (114 × 114)	20.25 (13 064)	435 (3)	8809 (39)	0.05 (1.3)
(Includes dried, unfired plastic or rammed refractories)	4.5 × 4.5 × 3 ^{C,D} (114 × 114 × 76)	4.5 × 4.5 (114 × 114)	20.25 (13 064)	435 (3)	8809 (39)	0.05 (1.3)
	2 × 2 × 2 ^{D,E} (51 × 51 × 51)	2 × 2 (51 × 51)	4 (2601)	435 (3)	1740 (7.80)	0.05 (1.3)
	2 diameter × 2 ^E (51 diameter × 51)	2, diameter (51, diameter)	3.14 (2027)	435 (3)	1367 (6.08)	0.05 (1.3)

^A Where possible, loading at a constant stress rate is preferable to constant strain rate loading.

^B For *dense* refractory brick and shapes requiring more than a 3-min test duration, specimens may be loaded to one half of the anticipated fracture strength at any convenient rate exceeding that specified.

^C These sizes are preferred for insulating firebricks.

^D These pieces may be cut from broken halves of MOR specimens.

^E These sizes are preferred for insulating castables.

$$S = W/A \quad (1)$$

where:

S = cold crushing strength, lbf/in.² (MPa),

W = total maximum load indicated by the testing machine, lbf (N), and

A = average of the areas of the top and bottom of the specimen perpendicular to the line of application of the load, in.² (mm²).

8. Report

8.1 Report the following:

8.1.1 Designation of the materials tested (that is, manufacturer, brand, description, lot number, etc.);

8.1.2 Specimen configuration, including size, shape, location in the original brick or shape, the character of the faces (that is, cut, drilled, as-pressed, as-cast, etc.), and the specimen orientation during testing;

8.1.3 Pretreatment, if any, given to the test pieces (for example, curing, firing, coking, etc.);

8.1.4 Number of specimens in a sample;

8.1.5 Individual specimen dimensions, the maximum applied load, and the calculated cold crushing strength for each specimen (see 7.1);

8.1.6 Mean cold crushing strength and standard deviation for each sample.

9. Precision and Bias

9.1 *Precision*—The precision of this test method is currently being investigated.

9.2 *Bias*—No justifiable statement can be made on the bias of the test method for measuring the cold crushing strength of refractories, because the value of cold crushing strength can be defined only in terms of a test method.

MODULUS OF RUPTURE

10. Apparatus

10.1 *Testing Machine*—Any form of standard mechanical or hydraulic compression testing machine conforming to the requirements of Practices E 4 may be used.

NOTE 4—Properly calibrated portable apparatus may be used.

10.2 *Bearing Surfaces*, that shall have a radius of curvature of 5/8 in. (16 mm) or be cylindrical pieces 1¼-in. (32-mm) in diameter. For 6- by 1- by 1-in. (152- by 25- by 25-mm) specimens, the radius of curvature shall be 3/16 in. (5 mm) or cylindrical pieces 3/8 in. (10 mm) in diameter. All such bearing surfaces shall be straight and of a length at least equal to the width of the test specimen. The supporting members for the lower bearing surfaces shall be constructed so as to provide a means for the alignment of the bearing surfaces with the under surface of the test specimen because the test brick may have a longitudinal twist. Apparatus of the design shown in Fig. 2 is recommended, although other types may be used, provided they conform to these requirements. A satisfactory alternative design is shown in Fig. 3.

11. Test Specimens

11.1 *Brick and Shapes (bulk density greater than 100 lb/ft³ (1.60 g/cm³))*—The preferred test specimens shall be standard 9- by 4½- by 2½- or 3-in. (228- by 114- by 64- or 76-mm) bricks, or specimens of equivalent size ground or cut from refractory shapes. In the case of special shapes, only one specimen shall be cut from a single shape. As many original surfaces as possible shall be preserved. Where brick sizes are impossible or impracticable, alternative specimen sizes of 9 by 2 by 2 in. (228 by 51 by 51 mm) or 6 by 1 by 1 in. (152 by 25 by 25 mm) may be prepared. In preparing specimens from irregular or larger shapes, any method involving the use of abrasives, such as a high-speed abrasion wheel or rubbing bed,

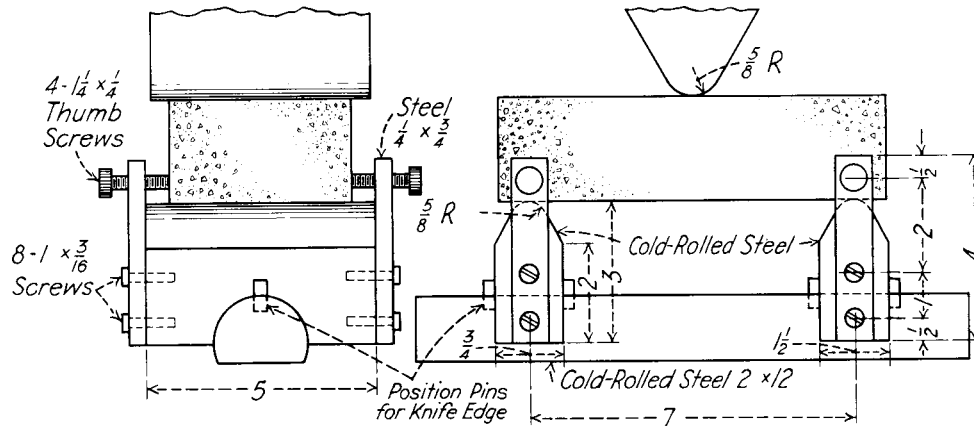

Transverse Brick Testing Apparatus

NOTE—The dimensions appearing in Fig. 2 are in inches. See table below for metric equivalents.

in.	mm	in.	mm
3/16	5	1 1/2	38
1/4	6	2	51
3/8	10	3	76
1/2	13	4	102
5/8	16	4 1/2	114
3/4	19	5	127
1	25	7	178
1 1/4	32	12	305

FIG. 2 Recommended Design of Bearing Cylinders for Modulus of Rupture Test

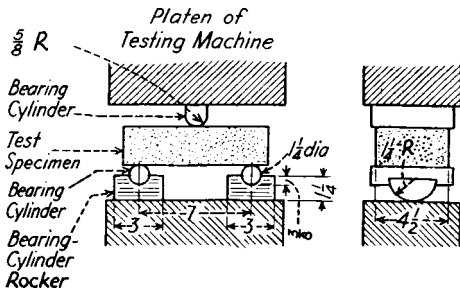

NOTE—The dimensions appearing in Fig. 3 are in inches. See table included with Fig. 2 for metric equivalents.

FIG. 3 Alternative Design of Bearing Cylinders for Modulus of Rupture Test

that will produce a specimen with approximately plane and parallel sides without weakening the structure may be used.

11.2 *Insulating Brick or Shapes* (typical bulk density of 100 lb/ft³ (1.60 g/cm³), or total porosity greater than 45 %, or both)—The test specimens shall be whole brick measuring 9 by 4 1/2 by 2 1/2 or 3 in. (228 by 114 by 64 or 76 mm), or specimens of equivalent size cut from larger shapes.

11.3 *Castable Refractories*—The test specimens shall be 9-by-2-by-2-in. (228-by-51-by-51-mm) bars prepared by casting or gunning. The top and bottom, and the side faces, respectively, shall be approximately parallel planes. All samples must be dried at 220 to 230°F (105 to 110°C) for 18 h (overnight). Upon removal from the oven, allow the sample to cool naturally until cool to the touch. Complete testing within 2 h of removal from the drying oven. (See Practices C 862 and C 1054.)

12. Procedure

12.1 At least five specimens from an equivalent number of refractory shapes compose a sample.

NOTE 5—For relatively weak specimens like insulating refractories, a minimum sample size of ten specimens is preferred.

12.2 Place a test specimen flat on the bearing cylinders with a span as specified in Table 2 and with the load applied at mid-span. Whenever possible, use an original, unbranded surface of a brick or shape as the tension face, that is, the face in contact with the two bottom bearing cylinders. For castable pieces, the depth dimension of the specimen as originally cast or gunned is horizontal; that is, the top surface of the casting or gunned sample becomes a side of the properly oriented test specimen.

12.3 Each specimen shall be broken at mid-span in flexure with a loading applied according to the standard loading rates given in Table 2. For high-strength materials requiring longer than about 3 min to perform a test, initial loading to one half of the anticipated failure load may be accomplished at any convenient rate exceeding the specified rate. Subsequently, the specimens should be loaded at the standard rate specified in Table 2. The rates shall not vary more than ±10 % from the stated rate for the type of refractory being tested. The maximum applied load is recorded.

12.4 When using a mechanical testing machine, keep the balance beam in a constantly floating position.

13. Calculation

13.1 Calculate the modulus of rupture using Eq 2:

TABLE 2 Standard Loading Rates for Modulus of Rupture

Refractory Type	Specimen Size, in. (mm)	Cross Section, in. (mm)	Span, in. (mm)	Stress Rate, lbf/in. ² /min (MPa/min)	Loading Rate, lbf/min (kN/min)	Strain Rate, ^A in./min (mm/min)	
<i>Refractory Brick and Shapes</i>							
Density >100 lb/ft ³ (>1.60 g/cm ³) or <45 % porosity, or both (Includes regular or high-strength castables and fired plastic or rammed refractories)	9 × 4.5 × 2.5 ^B (228 × 114 × 64)	4.5 × 2.5 (114 × 64)	7 (178)	1305 (9)	3496 (15.55)	0.05 (1.3)	
	9 × 4.5 × 3 ^B (228 × 114 × 76)	4.5 × 3 (114 × 76)	7 (178)	1305 (9)	5034 (22.39)	0.05 (1.3)	
	9 × 2 × 2 ^C (228 × 51 × 51)	2 × 2 (51 × 51)	7 (178)	1305 (9)	994 (4.42)	0.05 (1.3)	
	6 × 1 × 1 (152 × 25 × 25)	1 × 1 (25 × 25)	5 (127)	1305 (9)	174 (0.774)	0.05 (1.3)	
	<i>Insulating Refractories</i>						
	Density <100 lb/ft ³ (<1.60 g/cm ³), or >45 % true porosity, or both (Includes dried, unfired plastic or rammed refractories)	9 × 4.5 × 2.5 ^B (228 × 114 × 64)	4.5 × 2.5 (114 × 64)	7 (178)	435 (3)	1165 (5.18)	0.05 (1.3)
9 × 4.5 × 3 ^B (228 × 114 × 76)		4.5 × 3 (114 × 76)	7 (178)	435 (3)	1678 (7.46)	0.05 (1.3)	
9 × 2 × 2 ^C (228 × 51 × 51)		2 × 2 (51 × 51)	7 (178)	435 (3)	331 (1.47)	0.05 (1.3)	

^A Where possible, loading at a constant stress rate is preferable to constant strain rate loading.

^B Preferred sizes for bricks and shapes. Required sizes for firebricks.

^C Preferred size for all castables.

$$MOR = 3PL/2bd^2 \quad (2)$$

where:

MOR = modulus of rupture, lbf/in.² (MPa),
P = maximum applied at rupture, lbf (N),
L = span between supports, in. (mm),
b = breadth or width of specimen, in. (mm), and
d = depth of specimen, in. (mm).

14. Report

14.1 Report the following:

14.1.1 Designation of the materials tested (that is, manufacturer, brand, description, lot number, etc.);

14.1.2 Specimen configuration, including size, location in the original brick or shape, the character of the faces (that is, cut, ground, as-pressed, as-cast, etc.), the specimen orientation during testing, and the load span;

14.1.3 Pretreatment, if any, given to the test pieces (for example, curing, firing, coking, etc.);

14.1.4 Number of specimens in a sample;

14.1.5 Individual specimen dimensions, the maximum applied load, the location of the fracture plane, and the calculated modulus of rupture for each specimen (see 13.1);

14.1.6 Mean modulus of rupture and standard deviation for each sample.

15. Precision and Bias

15.1 *Interlaboratory Test Data*—An interlaboratory study was completed among eight laboratories in 1995. Four different types of refractories were tested for cold crushing strength and cold modulus of rupture by each laboratory. The four types of refractories were a dense firebrick, an insulating firebrick, a dense castable, and an insulating castable. The dimensions of the firebricks were 9 × 4.5 × 2.5 in., and the dimensions of the castables were 9 × 2 × 2 in. Before testing, bulk density and sonic velocity were measured on all refractory bricks to ensure uniformity. Refractory bricks were then randomly selected for distribution to the participating laboratories.

15.2 *Precision*—Table 3 and Table 4 contain the precision statistics for the cold crushing strength and cold modulus of rupture results, respectively.

15.2.1 *Repeatability*—The maximum permissible difference due to test error between two test results obtained by one operator on the same material using the same test equipment is given by the repeatability interval (*r*) and the relative repeatability interval (% *r*). The 95 % intervals are given in Table 3 and Table 4. Two test results that do not differ by more than the repeatability interval will be considered to be from the same population; conversely, two test results that do differ by more than the repeatability interval will be considered to be from different populations.

TABLE 3 Precision Statistics for Cold Crushing Strength

Material	Average, psi	Standard	Standard	Repeatability	Reproducibility	Coefficient of	Coefficient of	Relative	Relative
		Deviation	Deviation						
		Within	Between	Interval,	Interval,	Within	Between	% <i>r</i>	% <i>R</i>
		Laboratories,	Laboratories,	<i>r</i>	<i>R</i>	Laboratories,	Laboratories,		
		<i>Sr</i>	<i>SR</i>			<i>Vr</i>	<i>VR</i>		
Dense Firebrick	8995	392.1	1445.1	1098	4046.2	4.36	16.06	12.2	45
Insulating Firebrick ^A	135	2.8	8.7	8	24.3	2.11	6.45	5.9	18.1
Dense Castable	5580	144.6	465	404.8	1301.9	2.59	8.33	7.3	23.3
Insulating Castable	640	11.8	76.9	33	215.3	1.84	12.01	5.2	33.6

^A Only seven laboratories participated in this test.

TABLE 4 Precision Statistics for Cold Modulus of Rupture

Material	Average, psi	Standard Deviation Within Laboratories, Sr	Standard Deviation Between Laboratories, SR	Repeatability Interval, r	Reproducibility Interval, R	Coefficient of Variation Within Laboratories, Vr	Coefficient of Variation Between Laboratories, VR	Relative Repeatability, % r	Relative Reproducibility, % R
Dense Firebrick	1853	69.8	263.4	195.5	737.5	3.77	14.21	10.5	39.8
Insulating Firebrick ^A	120	2.3	16.6	6.5	46.5	1.94	13.86	5.4	38.8
Dense Castable	810	25.1	59.3	70.4	166.1	3.1	7.33	8.7	20.5
Insulating Castable	193	6.6	22.9	18.6	64	3.43	11.83	9.6	33.1

^A Only seven laboratories participated in this test.

15.2.2 *Reproducibility*—The maximum permissible difference due to test error between two test results obtained by two operators in different laboratories on the same material using the same test equipment is given by the reproducibility interval (R) and the relative reproducibility interval (% R). The 95 % reproducibility intervals are given in Table 3 and Table 4. Two test results that do not differ by more than the reproducibility interval will be considered to be from the same population; conversely, two test results that do differ by more than the reproducibility interval will be considered to be from different populations.

15.3 *Bias*—No justifiable statement can be made on the bias of the test method for measuring the modulus of rupture of refractories because the value of the modulus of rupture can be defined only in terms of a test method.

16. Keywords

16.1 crushing strength; modulus of rupture; monolithic refractories; refractory brick; room temperature

ASTM International takes no position respecting the validity of any patent rights asserted in connection with any item mentioned in this standard. Users of this standard are expressly advised that determination of the validity of any such patent rights, and the risk of infringement of such rights, are entirely their own responsibility.

This standard is subject to revision at any time by the responsible technical committee and must be reviewed every five years and if not revised, either reapproved or withdrawn. Your comments are invited either for revision of this standard or for additional standards and should be addressed to ASTM International Headquarters. Your comments will receive careful consideration at a meeting of the responsible technical committee, which you may attend. If you feel that your comments have not received a fair hearing you should make your views known to the ASTM Committee on Standards, at the address shown below.

This standard is copyrighted by ASTM International, 100 Barr Harbor Drive, PO Box C700, West Conshohocken, PA 19428-2959, United States. Individual reprints (single or multiple copies) of this standard may be obtained by contacting ASTM at the above address or at 610-832-9585 (phone), 610-832-9555 (fax), or service@astm.org (e-mail); or through the ASTM website (www.astm.org).