



Standard Test Method for Monotonic Compressive Strength Testing of Continuous Fiber-Reinforced Advanced Ceramics with Solid Rectangular Cross-Section Test Specimens at Ambient Temperatures¹

This standard is issued under the fixed designation C 1358; the number immediately following the designation indicates the year of original adoption or, in the case of revision, the year of last revision. A number in parentheses indicates the year of last reapproval. A superscript epsilon (ϵ) indicates an editorial change since the last revision or reapproval.

1. Scope

1.1 This test method covers the determination of compressive strength including stress-strain behavior under monotonic uniaxial loading of continuous fiber-reinforced advanced ceramics at ambient temperatures. This test method addresses, but is not restricted to, various suggested test specimen geometries as listed in the appendix. In addition, test specimen fabrication methods, testing modes (force, displacement, or strain control), testing rates (force rate, stress rate, displacement rate, or strain rate), allowable bending, and data collection and reporting procedures are addressed. Compressive strength as used in this test method refers to the compressive strength obtained under monotonic uniaxial loading where monotonic refers to a continuous nonstop test rate with no reversals from test initiation to final fracture.

1.2 This test method applies primarily to advanced ceramic matrix composites with continuous fiber reinforcement: uni-directional (1-D), bi-directional (2-D), and tri-directional (3-D) or other multi-directional reinforcements. In addition, this test method may also be used with glass (amorphous) matrix composites with 1-D, 2-D, 3-D, and other multi-directional continuous fiber reinforcements. This test method does not directly address discontinuous fiber-reinforced, whisker-reinforced, or particulate-reinforced ceramics, although the test methods detailed here may be equally applicable to these composites.

1.3 The values stated in SI units are to be regarded as the standard and are in accordance with [SI 10-02 IEEE/ASTM SI 10](#).

1.4 *This standard does not purport to address all of the safety concerns, if any, associated with its use. It is the responsibility of the user of this standard to establish appropriate safety and health practices and determine the applicability of regulatory limitations prior to use. Refer to Section 7 for specific precautions.*

¹ This test method is under the jurisdiction of ASTM Committee C28 on Advanced Ceramics and is the direct responsibility of Subcommittee C28.07 on Ceramic Matrix Composites.

Current edition approved June 1, 2005. Published July 2005. Originally approved in 1996. Last previous edition approved in 2000 as C 1358 – 96 (2000).

2. Referenced Documents

2.1 *ASTM Standards:*²

- [C 1145](#) Terminology of Advanced Ceramics
- [D 695](#) Test Method for Compressive Properties of Rigid Plastics
- [D 3379](#) Test Method for Tensile Strength and Young's Modulus for High-Modulus Single-Filament Materials
- [D 3410/D 3410M](#) Test Method for Compressive Properties of Polymer Matrix Composite Materials With Unsupported Gage Section by Shear Loading
- [D 3479/D 3479M](#) Test Method for Tension-Tension Fatigue of Polymer Matrix Composite Materials
- [D 3878](#) Terminology for Composite Materials
- [E 4](#) Practices for Force Verification of Testing Machines
- [E 6](#) Terminology Relating to Methods of Mechanical Testing
- [E 83](#) Practice for Verification and Classification of Extensometer System
- [E 337](#) Test Method for Measuring Humidity with Psychrometer (the Measurement of Wet-and Dry-Bulb Temperatures)
- [E 1012](#) Practice for Verification of Specimen Alignment Under Tensile Loading
- [SI 10-02 IEEE/ASTM SI 10](#) American National Standard for Use of the International System of Units (SI): The Modern Metric System

3. Terminology

3.1 *Definitions:*

3.1.1 The definitions of terms relating to compressive testing, advanced ceramics, and fiber-reinforced composites, appearing in Terminology [E 6](#), Test Method [D 695](#), Practice [E 1012](#), Terminology [C 1145](#), Test Method [D 3410/D 3410M](#), and Terminology [D 3878](#) apply to the terms used in this test method. Pertinent definitions are shown as follows with the appropriate source given in parentheses. Additional terms used in conjunction with this test method are defined in [3.2](#).

² For referenced ASTM standards, visit the ASTM website, www.astm.org, or contact ASTM Customer Service at service@astm.org. For *Annual Book of ASTM Standards* volume information, refer to the standard's Document Summary page on the ASTM website.

3.2 Definitions of Terms Specific to This Standard:

3.2.1 *advanced ceramic*, *n*—highly engineered, high-performance predominantly non-metallic, inorganic, ceramic material having specific functional attributes. **C 1145**

3.2.2 *axial strain* [LL^{-1}], *n*—average longitudinal strains measured at the surface on opposite sides of the longitudinal axis of symmetry of the specimen by two strain-sensing devices located at the mid length of the reduced section. **E 1012**

3.2.3 *bending strain* [LL^{-1}], *n*—difference between the strain at the surface and the axial strain. In general, the bending strain varies from point to point around and along the reduced section of the specimen. **E 1012**

3.2.4 *breaking force* [F], *n*—force at which fracture occurs. **E 6**

3.2.5 *ceramic matrix composite*, *n*—material consisting of two or more materials (insoluble in one another), in which the major, continuous component (matrix component) is a ceramic, while the secondary component(s) (reinforcing component) may be ceramic, glass-ceramic, glass, metal, or organic in nature. These components are combined on a macroscale to form a useful engineering material possessing certain properties or behavior not possessed by the individual constituents.

3.2.6 *compressive strength* [FL^{-2}], *n*—maximum compressive stress which a material is capable of sustaining. Compressive strength is calculated from the maximum force during a compression test carried to rupture and the original cross-sectional area of the specimen. **E 6**

3.2.7 *continuous fiber-reinforced ceramic matrix composite (CFCC)*, *n*—ceramic matrix composite in which the reinforcing phase consists of a continuous fiber, continuous yarn, or a woven fabric.

3.2.8 *gage length* [L], *n*—original length of that portion of the specimen over which strain or change of length is determined. **E 6**

3.2.9 *modulus of elasticity* [FL^{-2}], *n*—ratio of stress to corresponding strain below the proportional limit. **E 6**

3.2.10 *proportional limit stress in compression* [FL^{-2}], *n*—greatest stress that a material is capable of sustaining without any deviation from proportionality of stress to strain (Hooke's law).

3.2.10.1 *Discussion*—Many experiments have shown that values observed for the proportional limit vary greatly with the sensitivity and accuracy of the testing equipment, eccentricity of loading, the scale to which the stress-strain diagram is plotted, and other factors. When determination of proportional limit is required, specify the procedure and sensitivity of the test equipment. **E 6**

3.2.11 *percent bending*, *n*—bending strain times 100 divided by the axial strain. **E 1012**

3.2.12 *slow crack growth (SCG)*, *n*—subcritical crack growth (extension) which may result from, but is not restricted to, such mechanisms as environmentally-assisted stress corrosion or diffusive crack growth. **C 1145**

4. Significance and Use

4.1 This test method may be used for material development, material comparison, quality assurance, characterization, reliability assessment, and design data generation.

4.2 Continuous fiber-reinforced ceramic matrix composites (CFCCs) are generally characterized by fine-grain sized (<50 μm) matrices and ceramic fiber reinforcements. In addition, continuous fiber-reinforced glass (amorphous) matrix composites can also be classified as CFCCs. Uniaxial-loaded compressive strength tests provide information on mechanical behavior and strength for a uniformly stressed CFCC.

4.3 Generally, ceramic and ceramic matrix composites have greater resistance to compressive forces than tensile forces. Ideally, ceramics should be compressively stressed in use, although engineering applications may frequently introduce tensile stresses in the component. Nonetheless, compressive behavior is an important aspect of mechanical properties and performance. The compressive strength of ceramic and ceramic composites may not be deterministic. Therefore, test a sufficient number of test specimens to gain an insight into strength distributions.

4.4 Compression tests provide information on the strength and deformation of materials under uniaxial compressive stresses. Uniform stress states are required to effectively evaluate any nonlinear stress-strain behavior that may develop as the result of cumulative damage processes (for example, matrix cracking, matrix/fiber debonding, fiber fracture, delamination, etc.) that may be influenced by testing mode, testing rate, effects of processing or combination of constituent materials, or environmental influences. Some of these effects may be consequences of stress corrosion or sub-critical (slow) crack growth which can be minimized by testing at sufficiently rapid rates as outlined in this test method.

4.5 The results of compression tests of test specimens fabricated to standardized dimensions from a particulate material or selected portions of a part, or both, may not totally represent the strength and deformation properties of the entire, full-size product or its in-service behavior in different environments.

4.6 For quality control purposes, results derived from standardized compressive test specimens may be considered indicative of the response of the material from which they were taken for given primary processing conditions and post-processing heat treatments.

4.7 The compressive behavior and strength of a CFCC are dependent on, and directly related to, the material. Analysis of fracture surfaces and fractography, though beyond the scope of this test method, are recommended.

5. Interferences

5.1 Test environment (vacuum, inert gas, ambient air, etc.) including moisture content (for example, relative humidity) may have an influence on the measured compressive strength. In particular, the behavior of materials susceptible to slow crack growth will be strongly influenced by test environment, testing rate, and test temperature. Conduct tests to evaluate the maximum strength potential of a material in inert environment or at sufficiently rapid testing rates, or both, to minimize slow crack growth effects. Conversely, conduct tests in environments or at test modes, or both, and rates representative of service conditions to evaluate material performance under use conditions. Monitor and report relative humidity and ambient temperature when testing is conducted in uncontrolled ambient

air with the intent of evaluating maximum strength potential. Testing at humidity levels >65 % relative humidity (RH) is not recommended.

5.2 Surface preparation of test specimens, although normally not considered a major concern in CFCCs, can introduce fabrication flaws that may have pronounced effects on compressive mechanical properties and behavior (for example, shape and level of the resulting stress-strain curve, compressive strength and strain, proportional limit stress and strain, etc.) Machining damage introduced during test specimen preparation can be either a random interfering factor in the determination of ultimate strength of pristine material (that is, increased frequency of surface-initiated fractures compared to volume-initiated fractures), or an inherent part of the strength characteristics to be measured. Surface preparation can also lead to the introduction of residual stresses. Universal or standardized test methods of surface preparation do not exist. In addition, the nature of fabrication used for certain composites (for example, chemical vapor infiltration or hot pressing) may require the testing of test specimens in the as-processed condition (that is, it may not be possible to machine the test specimen faces without compromising the in-plane fiber architecture). Final machining steps may, or may not, negate machining damage introduced during the initial machining. Thus, report test specimen fabrication history since it may play an important role in the measured strength distributions.

5.3 Bending in uniaxial compressive tests can introduce eccentricity leading to geometric instability of the test specimen and buckling failure before true compressive strength is attained. In addition, if deformations or strains are measured at surfaces where maximum or minimum stresses occur, bending may introduce over or under measurement of strains depending on the location of the strain-measuring device on the test specimen. Bending can be introduced from, among other sources, initial load train misalignment, misaligned test specimens, or load train misalignment introduced during testing due to low lateral machine/grip stiffness.

5.4 Fractures that initiate outside the uniformly stressed gage section of a test specimen may be due to factors such as stress concentrations or geometrical transitions, extraneous stresses introduced by gripping, or strength-limiting features in the microstructure of the test specimen. Such non-gage section fractures will normally constitute invalid tests. In addition, for frictional face-loaded geometrics, gripping pressure is a key variable in the initiation of fracture. Insufficient pressure can shear the outer plies in laminated CFCCs; while too much pressure can cause local crushing of the CFCC and may initiate fracture in the vicinity of the grips.

5.5 Lateral supports are sometimes used in compression tests to reduce the tendency of test specimen buckling. However, such lateral supports may introduce sufficient frictional stress so as to artificially increase the force required to produce compressive failure. In addition, the lateral supports and attendant frictional stresses may invalidate the assumption of uniaxial stress state. When lateral supports are used, the frictional effect should be quantified to ensure that its contri-

bution is small, and the means for doing so reported along with the quantity of the frictional effect.

6. Apparatus

6.1 *Testing Machines*— Machines used for compressive testing shall conform to Practices E 4. The forces used in determining compressive strength shall be accurate within ±1 % at any force within the selected load range of the testing machine as defined in Practices E 4. A schematic showing pertinent features of one possible compressive testing apparatus is shown in Fig. 1.

6.2 *Gripping Devices:*

6.2.1 *General*—Various types of gripping devices may be used to transmit the measured force applied by the testing machine to the test specimens. The brittle nature of the matrices of CFCCs requires a uniform interface between the grip components and the gripped section of the test specimen. Line or point contacts and nonuniform pressure can produce Hertzian-type stresses leading to crack initiation and fracture of the test specimen in the gripped section.

6.2.1.1 The primary recommended gripping system for compressive testing CFCCs employs active grip interfaces that require a continuous application of a mechanical, hydraulic, or pneumatic force to transmit the force applied by the test machine to the test specimen. These types of grip interfaces (that is, frictional face-loaded grips) cause a force to be applied normal to the surface of the gripped section of the test specimen. Transmission of the uniaxial force applied by the test machine is then accomplished by friction between the test specimen and the grip faces. Thus, important aspects of active grip interfaces are uniform contact between the gripped section

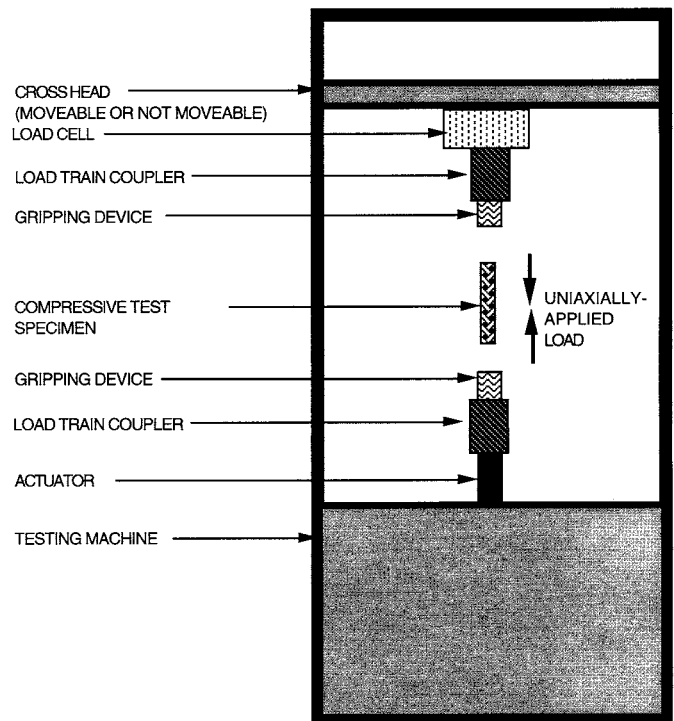

FIG. 1 Schematic Diagram of One Possible Apparatus for Conducting a Uniaxially-Loaded Compression Test

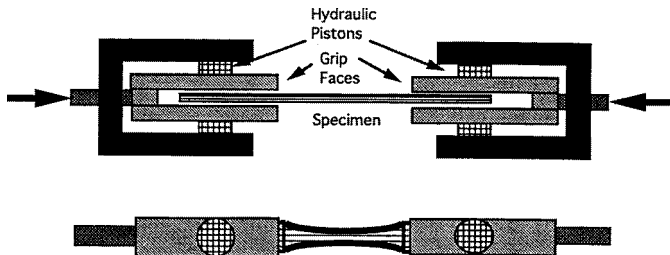

FIG. 2 Example of a Direct Lateral Pressure Grip Face for a Face-Loaded Grip Interface

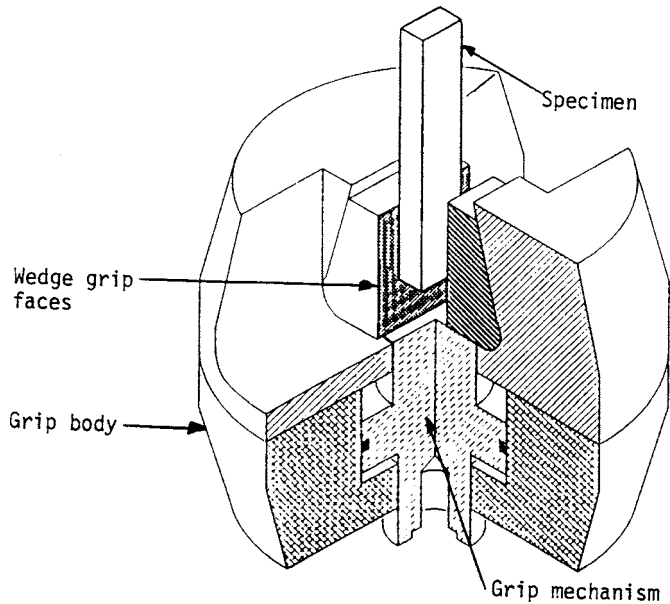

FIG. 3 Example of an Indirect Wedge-Type Grip Faces for a Face-Loaded Grip Interface

of the test specimen and the grip faces and constant coefficient of friction over the grip/specimen interface.

6.2.1.2 For flat test specimens, frictional face-loaded grips, either by direct lateral pressure grip faces (1)³ or by indirect wedge-type grip faces, act as the grip interface (2,3) as illustrated in Fig. 2 and Fig. 3, respectively. Generally, close tolerances are required for the flatness and parallelism as well as for the wedge angle of the wedge grip faces. In addition, the thickness, flatness, and parallelism of the gripped section of the test specimen must be within similarly close tolerances to promote uniform contact at the test specimen/grip interface. Tolerances will vary depending on the exact configuration as shown in the appropriate test specimen drawings.

6.2.1.3 Sufficient lateral pressure must be applied to prevent slippage between the grip face and the test specimen. Grip surfaces that are scored or serrated with a pattern similar to that of a single-cut file have been found satisfactory. A fine serration appears to be the most satisfactory. Keep the serrations clean and well-defined but not overly sharp. The length

and width of the grip faces shall be equal to or greater than the respective length and width of the gripped sections of the test specimen.

6.2.1.4 An alternative recommended gripping system for compressive testing CFCCs employs passive grip interfaces which employ lateral supports and loading anvils to transmit the applied force to the compressive test specimen. The lateral supports prevent both buckling of the test specimen in the gage section and splitting and brooming of the 'grip' section. Transmission of the force applied by the test machine is then accomplished by a directly applied uniaxial force to the test specimen ends. Thus, important aspects of this type of grip interface are uniform contact between the loading anvil and the test specimen and good contact between the test specimen and lateral supports.

6.2.1.5 For flat test specimens, a controlled, face-supported fixture (4) as illustrated in Fig. 4 can be used. Generally, close tolerances are required for the flatness and parallelism. In addition, the thickness, flatness, and parallelism of the supported section of the test specimen must be within similarly close tolerances to promote uniform contact at the test specimen/lateral support interface. Tolerances will vary depending on the exact configuration as shown in the appropriate test specimen drawings.

6.3 Load Train Couplers:

6.3.1 General—Various types of devices (load train couplers) may be used to attach the active or passive grip interface assemblies to the testing machine. The load train couplers in conjunction with the type of gripping device play major roles in the alignment of the load train and thus subsequent bending (that is, eccentricity) imposed in the test specimen. Fixed, but

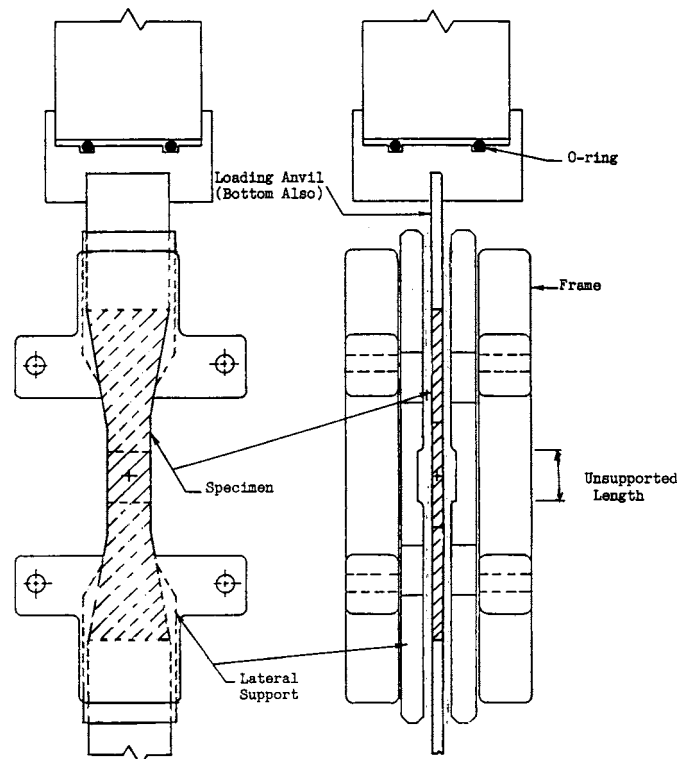

FIG. 4 Example of a Controlled Face Supported Fixture (4)

³ The boldface numbers given in parentheses refer to a list of references at the end of the text.

adjustable load train couplers are primarily recommended for compression testing CFCCs to ensure a consistently well-aligned load train for the entire test. The use of well-aligned fixed couplers does not automatically guarantee low bending (that is, eccentricity) in the gage section of the compressive test specimen. Well-aligned fixed couplers provide for well-aligned load trains, but the type and operation of grip interfaces as well as the as-fabricated dimensions of the compressive test specimen can add significantly to the final bending (that is, eccentricity) imposed in the gage section of the test specimen.

6.3.1.1 As a minimum, verify the alignment of the testing system at the beginning and end of a test series unless the conditions for verifying alignment are otherwise met. An additional verification of alignment is recommended, although not required, at the middle of the test series. Use either a dummy or actual test specimen. Allowable bending requirements are discussed in 6.5. See Practice E 1012 for discussions of alignment and Appendix X1 for suggested procedures specific to this test method. A test series is interpreted to mean a discrete group of tests on individual test specimens conducted within a discrete period of time on a particular material configuration, test specimen geometry, test condition, or other uniquely definable qualifier (for example, a test series composed of material A comprising ten test specimens of geometry B tested at a fixed rate in strain control to final fracture in ambient air).

NOTE 1—Compressive test specimens used for alignment verification should be equipped with a recommended eight separate longitudinal strain gages to determine bending contributions from both eccentric and angular misalignment of the grip heads. Ideally, the verification test specimen should be of identical material to that being tested. However, in the case of CFCCs the type of reinforcement or degree of residual porosity may complicate the consistent and accurate measurement of strain. Therefore, use an alternate material (isotropic, homogeneous, continuous) with similar elastic modulus, elastic strain capability, and hardness to the test material. In addition, dummy test specimens used for alignment verification, should have the same geometry and dimensions of the actual test specimens as well as similar mechanical properties as the test material to ensure similar axial and bending stiffness characteristics as the actual test specimen and material.

6.3.2 Fixed load train couplers may incorporate devices which require either a one-time, pretest alignment adjustment of the load train which remains constant for all subsequent tests or an *in situ*, pretest alignment of the load train which is conducted separately for each test specimen and each test. Such devices (2) usually employ angularity and concentricity adjusters to accommodate inherent load train misalignments. Regardless of which method is used, perform an alignment verification as discussed in 6.3.1.1.

6.4 *Strain Measurement*—Determine strain by means of either a suitable extensometer or strain gages.

6.4.1 Extensometers used for compressive testing of CFCCs test specimens shall satisfy Practice E 83, Class B-1 requirements and are recommended to be used in place of strain gages for test specimens with gage lengths of ≥ 25 mm and shall be used for high-performance tests beyond the range of strain gage applications. Calibrate extensometers periodically in accordance with Practice E 83. For extensometers which mechanically contact the test specimen, the contact shall not cause

damage to the test specimen surface. However, shallow grooves (0.025 to 0.051 mm deep) machined into the surfaces of CFCCs to prevent extensometer slippage have been shown to not have a detrimental effect on failure strengths (4). In addition, support the weight of the extensometer so as not to introduce bending greater than that allowed in 6.5.

6.4.2 An additional recommendation but not requirement for the actual testing is strain determined directly from strain gages. Two strain gages, one mounted on each of the opposite faces of the width surfaces, can be used to monitor incidences of bending eccentricity and, hence, tendency to buckling. Buckling can be detected when the strain on one face reverses (decreases) while the strain on the other face increases rapidly.

NOTE 2—If Poisson's ratio is to be determined, instrument the test specimen to measure strain in both longitudinal and lateral directions at the same position on the test specimen. Either a stacked, biaxial strain gage or two suitably oriented uniaxial strain gages (attached as close to each other as possible) are suitable for this purposes.

NOTE 3—Unless it can be shown that strain gage readings are not unduly influenced by localized strain events such as fiber crossovers, strain gages should not be less than 9 to 12 mm in length for the strain-measurement direction and not less than 6 mm in width for the direction normal to strain measurement. Larger strain gages than those recommended here may be required for fabric reinforcements to average the localized strain effects of the fiber crossovers. Choose the strain gages, surface preparation, and bonding agents so as to provide adequate performance on the subject materials. Employ suitable strain recording equipment. Many CFCCs may exhibit high degrees of porosity and surface roughness and therefore require surface preparation including surface filling before the strain gages can be applied.

6.5 *Allowable Bending*—Axial misalignment of the introduction of bending, due either to eccentricity or angular misalignment, will produce a geometric instability in the compressive test specimen leading to buckling and measured compressive strengths less than the true compressive strength. One study on polymeric composites has indicated that a misalignment of even 2.5 % bending, as defined in Practice E 1012, will cause an apparent strength drop to only 87 % of the ultimate compressive strength (5).

6.5.1 Actual studies of the effect of bending on the compressive strength distributions of CFCCs do not exist. Until such information is forthcoming for CFCCs, this test method adopts a conservative recommendation of the lowest achievable percent bending for compressive testing CFCCs. Therefore, the maximum allowable percent bending at the onset of the cumulative fracture process (for example, non linearity in the compressive stress-strain curve) for test specimens tested under this test method shall not exceed five, with one recommended, at a mean strain equal to either one half the anticipated strain at the onset of the cumulative fracture process (for example, non linearity in the compressive stress-strain curve) or a strain of -0.0005 (that is, -500 microstrain) whichever is greater. Unless all test specimens are properly strain gaged and percent bending monitored until the onset of the cumulative fracture process, there will be no record of percent bending at the onset of fracture for each test specimen. Therefore, verify the alignment of the testing system. See Practice E 1012 for discussions of alignment and Appendix X1 for suggested procedure specific to this test method.

NOTE 4—Lateral stiffness of the grip/machine (in addition to misaligned grips/load train, test specimens misaligned in the grips, or misshapen test specimens) will influence load train alignment and the resulting eccentricity introduced in the test specimen. Therefore, unlike a tension test which may produce a certain amount of self-alignment at increasing forces in a compliant load train, a compression test may produce a certain amount of misalignment at increasing forces in a compliant load train. Therefore, lateral grip/machine stiffnesses as high as possible are recommended for compression tests. Increasing bending with increasing force as measured in the alignment verification is an indication of a low lateral stiffness of the grip/machine (among other sources).

6.6 Data Acquisition— Obtain, at the minimum, an autographic record of applied force and gage section deformation (or strain) versus time. Either analog chart recorders or digital data acquisition systems can be used for this purpose although a digital record is recommended for ease of later data analysis. Ideally, use an analog chart recorder or plotter in conjunction with the digital data acquisition system to provide an immediate record of the test as a supplement to the digital record. Recording devices shall be accurate to within $\pm 1\%$ of the selected range for the testing system including readout unit, as specified in Practices E 4, and should have a minimum data acquisition rate of 10 Hz with a response of 50 Hz deemed more than sufficient.

6.6.1 Record strain or deformation of the gage section, or both, either similarly to the force or as independent variables of force. Cross-head displacement of the test machine may also be recorded but should not be used to define displacement or strain in the gage section.

6.7 Dimension-Measuring Devices—Micrometers and other devices used for measuring linear dimensions shall be accurate and precise to at least one half the smallest unit to which the individual dimension is required to be measured. Measure cross-sectional dimensions to within 0.02 mm using dimension-measuring devices with accuracies of 0.01 mm.

7. Precautionary Statement

7.1 During the conduct of this test method, the possibility of flying fragments of broken test material may be high. The brittle nature of advanced ceramics and the release of strain energy contribute to the potential release of uncontrolled fragments upon fracture. Means for containment and retention of these fragments for safety as well as later fractographic reconstruction and analysis is highly recommended.

7.2 Exposed fibers at the edges of CFCC test specimens present a hazard due to the sharpness and brittleness of the ceramic fiber. Inform all those required to handle these materials of such conditions and the proper handling techniques.

8. Test Specimen

8.1 Test Specimen Geometry:

8.1.1 General—Unlike tensile tests, in which test specimens with reduced (or contoured) gage sections are used to minimize non-gage section failures, in compressive tests anisotropy and sensitivity to the geometric instability of buckling may discourage the use of contoured test specimens. Generally, straight-sided test specimens are recommended for compression tests. However, contoured compressive test specimens have been used successfully to test some types of CFCCs (4).

NOTE 5—The final dimensions of compressive test specimens are dependent on the ultimate use of the compressive strength data. For example, if the compressive strength of an as-fabricated component is required, the dimensions of the resulting compressive test specimen may reflect the thickness, width, and length restrictions of the component. If it is desired to evaluate the effects of interactions of various constituent materials for a particular CFCC manufactured via a particular processing route, then the size of the test specimen and resulting gage section will reflect the desired volume to be sampled.

8.1.1.1 The following paragraphs discuss recommended test specimen geometries, although any geometry is acceptable if it meets the gripping, fracture location, and bending requirements of this test method. Deviations from the recommended geometries may be necessary depending upon the particular CFCC being evaluated. Conduct stress analyses of untried test specimen geometries to ensure that stress concentrations, that can lead to undesired fractures outside the gage sections, do not exist. Contoured test specimens by their nature contain inherent stress concentrations due to geometric transitions. Stress analyses can indicate the magnitude of such stress concentrations while revealing the success of producing a uniform compressive stress state in the gage section of the test specimen.

8.1.1.2 Fig. 5 shows the nomenclature and an example of a straight-sided test specimen (3) that can be used in either the frictional face-loaded grips or the controlled face-supported fixture. Important tolerances for this geometry include parallelism and flatness of faces all of which will vary depending on the exact configuration as shown in the appropriate test specimen drawing.

8.1.1.3 Fig. 6 shows the nomenclature and an example of a contoured, “bow-tie” test specimen (4) that can be used in either the frictional face-loaded grips or the controlled face-supported fixture. Important tolerances for the face-loaded geometry include parallelism and flatness of faces which will vary depending on the exact configuration as shown in the appropriate test specimen drawing.

8.2 The recommended minimum gage length of the test specimen is 25 mm with the length of at least 50 mm of the gripped sections at each end of the test specimen. Recommended minimum width and minimum thickness are 10 and 3 mm, respectively. However, other combinations of gage length, width, and thickness can be used as long as the slenderness ratio, l/k , ≤ 30 (6,7).

8.2.1 The slenderness ratio can be calculated as:

$$\frac{l}{k} = \sqrt{12} \frac{l}{b} \quad (1)$$

where:

l = length of the gage section,

k = least radius of gyration of the cross section, and

b = thickness of the cross section.

The investigations reported in Refs. (6) and (7) indicate that measured compressive strengths of composites were independent of slenderness ratios (that is, presumably indicative of the true compressive strength) for $l/k \leq 30$.

8.3 For the frictional, face-loaded grips, end tabs may be required to provide a compliant layer for gripping and to prevent splitting and brooming of the gripped ends of the test

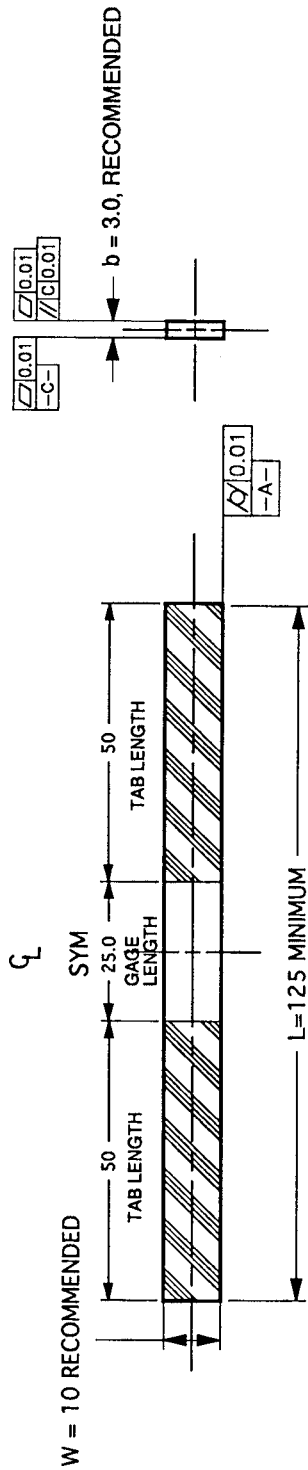

NOTE: 1) MINIMUM L = 125 mm WITH 25 mm GAGE SECTION. RECOMMENDED W = 10 mm.
 2) SURFACE FINISH 0.5- 1.0 μm ALL OVER EXCEPT END FACES WHICH MAY BE 1.0-2.0 μm.
 3) FINAL GRIND OF GAGE SECTION TO BE LONGITUDINAL

Compression Specimen for CFCCs
mm X.X = 0.1, X.XX = 0.01, X.XXX = 0.001
SCALE: NTS

NOTE 1—Illustration not intended to be an engineering or production drawing, or both.

FIG. 5 Example of a Straight-Sided Compressive Test Specimen

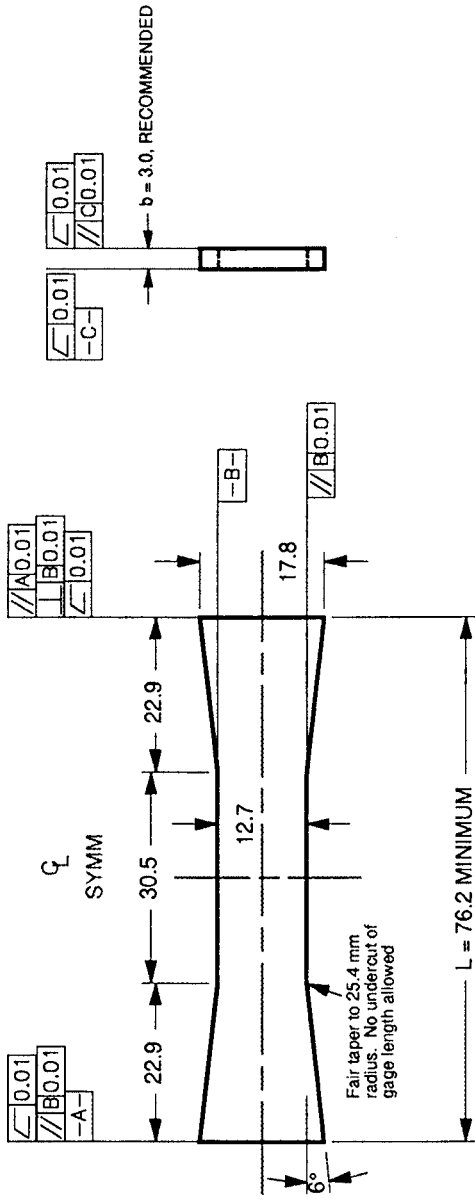

- NOTE: 1) MINIMUM L = 76.2 mm WITH 30.5 mm GAGE SECTION. RECOMMENDED W = 12 mm.
 2) SURFACE FINISH 0.5- 1.0 μm ALL OVER
 3) FINAL GRIND OF GAGE SECTION TO BE LONGITUDINAL

Compression Specimen for CFCCs
mm X.X = 0.1, X.XX = 0.01, X.XXX = 0.001 SCALE: NTS

NOTE 1—Illustration not intended to be an engineering or production drawing, or both.
 FIG. 6 Example of a 'Bow-Tie' Compressive Test Specimen (4)

specimens. Balanced 0/90° cross-ply tabs made from unidirectional non-woven E-glass have proven to be satisfactory for certain fiber-reinforced polymers. For CFCCs, tab materials comprised of fiber-glass reinforced epoxy, polymethylene resins (PMR), or carbon fiber-reinforced resins have been used successfully (8). However metallic tabs (for example, aluminum alloys) may be satisfactory as long as the tabs are strain compatible (that is, having a similar bulk elastic modulus within $\pm 10\%$ of that of the CFCC) with the CFCC material being tested. Each beveled tab (bevel angle $< 15^\circ$) should be a minimum of 50 mm long, the same width of the test specimen, and have the total thickness of the tabs on the order of the thickness of the test specimen. Any high-elongation (tough) adhesive system may be used with the length of the tabs determined by the shear strength of the adhesive, size of the test specimen, and estimated strength of the composite. In any case, if a significant fraction ($\geq 20\%$) of fractures occur within one test specimen width of the tab, re-examine the tab materials and configuration, gripping method and adhesive, and make necessary adjustment to promote fracture within the gage section. Fig. 7 shows an example of a tab design modified to be used for compressive testing of CFCCs.

8.4 Specimen Preparation:

8.4.1 Depending upon the intended application of the compressive strength data, use one of the following test specimen preparation procedures. Regardless of the preparation procedure used, report sufficient details regarding the procedure to allow replication.

8.4.2 *As-Fabricated*—The compressive test specimen simulates the surface/edge conditions and processing route of an application where no machining is used; for example, as-cast, sintered, or injection molded part. No additional machining specifications are relevant. As-processed test specimens might possess rough surface textures and non-parallel edges and as such may cause excessive misalignment or be prone to non-gage section fractures, or both.

8.4.3 *Application-Matched Machining*—The compressive test specimen has the same surface/edge preparation as that given to the component. Unless the process is proprietary, report the stages of material removal, wheel grits, wheel bonding, amount of material removed per pass, and type of coolant used.

8.4.4 *Customary Practices*—In instances where a customary machining procedure has been developed that is completely satisfactory for a class of materials (that is, it induces no unwanted surface/subsurface damage or residual stresses), use this procedure.

8.4.5 *Standard Procedure*—In instances where 8.4.2 through 8.4.4 are not appropriate, 8.4.5 shall apply. Studies to evaluate the machinability of CFCCs have not been completed. Therefore, the standard procedure of 8.4.5 can be viewed as preliminary guidelines and a more stringent procedure may be necessary.

8.4.5.1 Conduct all grinding or cutting with ample supply of appropriate filtered coolant to keep the workpiece and grinding wheel constantly flooded and particles flushed. Grinding can be done in at least two stages, ranging from coarse to fine rate of

material removal. All cutting can be done in one stage appropriate for the depth of cut.

8.4.5.2 Stock removal rate should be on the order of 0.03 mm per pass using diamond tools that have between 320 and 600 grit. Remove equal stock from each face where applicable.

8.5 *Handling Precaution*—Exercise care in storing and handling finished test specimens to avoid the introduction of random and severe flaws. In addition, pay attention to pre-test storage of test specimens in controlled environments or desiccators to avoid unquantifiable environmental degradation of test specimens prior to testing. If conditioning is required, Test Methods D 3479/D 3479M recommend conditioning and testing polymeric composite test specimens in a room or enclosed space maintained at a temperature and relative humidity of $23 \pm 3^\circ\text{C}$ and $65 \pm 10\%$, respectively. Measure ambient conditions in accordance with Test Method E 337.

8.6 *Number of Test Specimens*—A minimum of five test specimens is required for the purpose of estimating a mean. A greater number of test specimens may be necessary if estimates regarding the form of the strength distribution are required. If material cost or test specimen availability limit the number of tests to be conducted, fewer tests may be conducted to determine an indication of material properties.

8.7 *Valid Tests*—A valid individual test is one which meets all the following requirements: all the testing requirements of this test method and, failure occurs in the uniformly stressed gage section unless those tests failing outside the gage section are interpreted as interrupted tests for the purpose of censored test analyses.

9. Procedure

9.1 *Specimen Dimensions*—Determine the thickness and width of the gage section of each test specimen to within 0.02 mm on at least three different cross-sectional planes in the gage section. To avoid damage in the critical gage section area make these measurements either optically (for example, an optical comparator) or mechanically using a flat, anvil-type micrometer. In either case the resolution of the instrument shall be as specified in 6.7. Exercise extreme caution to prevent damage to the test specimen gage section. Ball-tipped or sharp-anvil micrometers may be preferred when measuring test specimens with rough or uneven surfaces. Record and report the measured dimensions and locations of the measurements for use in the calculation of the compressive stress. Use the average of the multiple measurements in the stress calculations.

9.1.1 Alternatively, to avoid damage to the gage section, post-fracture measurement of the gage section dimensions can be made using procedures described in 9.1. In some cases, the fracture process can severely fragment the gage section in the immediate vicinity of the fracture, thus making post-fracture measurements of dimensions difficult. In these cases, it is advisable to follow the procedures outlined in 9.1 for pretest measurements to ensure reliable measurements.

9.1.2 Conduct periodic, if not 100%, inspection/measurements of all test specimens and test specimen dimensions to ensure compliance with the drawing specifications. Generally, high-resolution optical methods (for example, an optical comparator) or high-resolution digital point contact methods (for example, coordinate measurement machine) are

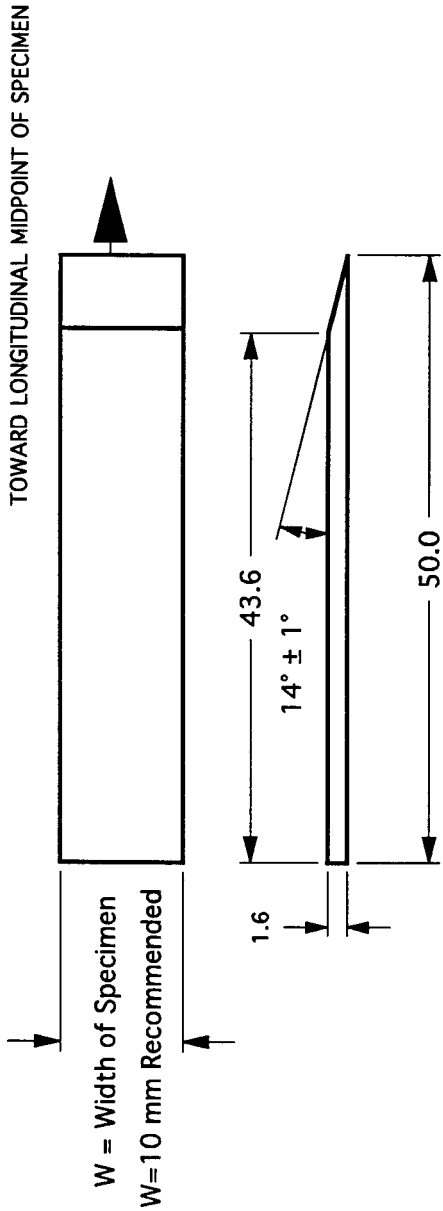

- NOTE: 1) SURFACE FINISH 0.5- 1.0 μm ALL OVER EXCEPT END FACES WHICH MAY BE 1.0-2.0 μm .
 2) FINAL GRIND OF GAGE SECTION TO BE LONGITUDINAL
 3) ANGLE OF BEVEL SHOULD BE $\leq 15^\circ$

Tabs for Compressive Specimens for CFCCs
mm X.X = 0.1, X.XX = 0.01, X.XXX = 0.001 SCALE: NTS

NOTE 1—Illustration not intended to be an engineering or production drawing, or both.

FIG. 7 Example of a Bevelled Tab Used Successfully for Face-Loaded CFCC Tensile Test Specimens

satisfactory, as long as the equipment meets the specifications in 6.7. The frequency of gage section fractures and bending in the gage section are dependent on proper overall test specimen dimensions within the required tolerances.

9.1.3 In some cases it is desirable, but not required, to measure surface finish to quantify the surface condition of the gage section. Such methods as contacting profilometry can be used to quantify surface roughness. Report surface roughness and direction of the measurement.

9.2 Test Modes and Rates:

9.2.1 *General*—Test modes and rates can have distinct and strong influences on fracture behavior of advanced ceramics even at ambient temperatures depending on test environment or condition of the test specimen. Test modes may involve force, displacement, or strain control. Recommended rates of testing are intended to be sufficiently rapid to obtain the maximum possible compressive strength at fracture of the material. However, rates other than those recommended here may be used to evaluate rate effects. In all cases, report the test mode and rate.

NOTE 6—For structural ceramics, load-controlled tests, with force generally related directly to compressive stress, is the preferred test mode. However, in CFCCs the non-linear stress-strain behavior in tension is characteristic of the ‘graceful’ fracture process of these materials indicating a cumulative damage process which is strain dependent. Generally, displacement- or strain-controlled tests are employed in such cumulative damage or yielding deformation processes to prevent a ‘run away’ condition (that is, rapid uncontrolled deformation and fracture) characteristic of load- or stress-controlled tests. Thus, to elucidate the potential ‘toughening’ mechanisms under controlled fracture of the CFCC, displacement or strain control is preferred. However, such behavior is dependent on the creation and propagation of tensile micro-cracks in the matrix. Such micro-cracks are not the prevalent fracture mode when CFCCs are tested in compression. Therefore, and especially for sufficiently rapid test rates, differences in the fracture process may not be noticeable and any of these test modes may be appropriate.

9.2.2 *Strain Rate*— Strain is the independent variable in non-linear analyses such as yielding. As such, strain rate is a method of controlling tests of deformation processes to avoid ‘runaway’ (that is, uncontrolled, rapid failure) conditions. For the linear elastic region of CFCCs, strain rate can be related to stress rate such that:

$$\dot{\epsilon} = \frac{d\epsilon}{dt} = \frac{\dot{\sigma}}{E} \quad (2)$$

where:

- $\dot{\epsilon}$ = strain rate in the test specimen gage section, s^{-1}
- ϵ = strain in the test specimen gage section,
- t = time, s,
- $\dot{\sigma}$ = nominal stress rate in the test specimen gage section, MPa/s, and
- E = elastic modulus of the CFCC, MPa.

Strain-controlled tests can be accomplished using an extensometer contacting the gage section of the test specimen as the primary control transducer.

NOTE 7—Compressive strain rates on the order of -50×10^{-6} to $-500 \times 10^{-6} s^{-1}$ are recommended to minimize environmental effects when testing in ambient air. Alternatively, select strain rates to produce final fracture in 5 to 10 s to minimize environmental effects when testing in ambient air.

9.2.3 *Displacement Rate*—The size differences of each test specimen geometry require a different loading rate for any given stress rate. As the test specimen begins to fracture, the strain rate in the gage section of the test specimen will change even though the rate of motion of the cross head remains constant. For this reason, displacement rate controlled tests can give only an approximate value of the imposed strain rate. Displacement mode is defined as the control of, or free-running displacement of, the test machine cross head. Thus, the displacement rate can be calculated as follows. Using the recommended (or desired) strain rate as detailed in 9.2.2, calculate the displacement rate for the linear elastic region of CFCCs only as:

$$\dot{\delta} = \frac{d\delta}{dt} \approx \left(\frac{1}{k_m} + \frac{1}{k_s} \right) \dot{\epsilon} EA = \left(\frac{1}{k_m} + \frac{1}{k_s} \right) \dot{\sigma} A \quad (3)$$

where:

- $\dot{\delta}$ = displacement rate of the cross head, mm/s,
- δ = cross-head displacement, mm,
- k_m = stiffness of the test machine and load train (including the test specimen ends and the grip interfaces), N/mm,
- k_s = stiffness of the uniform gage section of the test specimen, N/mm,
- E = elastic modulus of the material, MPa, and
- A = cross-sectional area of the gage section.

Calculate the cross-sectional area, A , as $A = w b$ for rectangular cross sections where w is the width of the gage section in units of mm, and b is the thickness of the gage section in units of mm.

NOTE 8—If L is the ungripped length of the test specimen, then k_s can be calculated as $k_s = A E/L$. The stiffness k_m can be determined as described in Test Method D 3379 by measuring the load-displacement curves for various test specimen lengths. The plot of k_m (slope of load-displacement curve) versus test specimen gage length is then extrapolated to zero to find the actual machine stiffness. Alternatively, k_m can be estimated using the manufacturer’s value for frame stiffness as a starting point and decreasing this value as necessary to account for various links in the load train. If such a method is used, report the assumptions and methods for approximating k_m .

9.2.4 *Force Rate*—For materials which do not experience gross changes in cross-sectional area of the gage section, force rate can be directly related to stress rate and hence to the recommended (or desired) strain rate. For the linear elastic region of CFCCs, calculate force rate as:

$$\dot{P} = \frac{dP}{dt} = \dot{\sigma} A \approx \dot{\epsilon} EA \quad (4)$$

where:

- \dot{P} = required force rate, N/s, and
- P = applied force, N.

NOTE 9—As the test specimen begins to fracture, the strain rate in the gage section of the test specimen will change even though the rate of force application remains constant. Stress rates > 35 to 50 MPa/s have been used with success (9) in tensile testing CFCCs to minimize the influence of environment effects. If environmental effects apply for compressive strengths, then similar test rates should be chosen to obtain the greatest value of ultimate compressive strength. Alternately, select stress or force rates to produce final fracture in 5 to 10 s to minimize environmental

effects when testing in ambient air.

9.2.5 Ramp Segments—Normally, tests are conducted in a single ramp function at a single test rate from zero force to the maximum force at fracture. However, in some instances multiple ramp segments might be employed although hold times are not allowed to avoid environmental effects. Record and report the type and timed duration of the ramp.

9.3 Conducting the Compression Test:

9.3.1 Mounting the Test Specimen—Normally the grip interface and test specimen geometry described in Section 8 will require only moderately unique procedures for mounting the test specimen in the load train. Identify and report any components which are required for each test. Mark the test specimen with an indelible marker as to the top, bottom, and front (side facing the operator) in relation to the test machine. In the case of strain-gaged test specimens, orient the test specimen such that the 'front' of the test specimen and a unique strain gage (for example, strain gage 1 designated SG1) coincide.

9.3.2 Preparation for Testing—Set the test mode and test rate on the test machine. Either mount the extensometer on the test specimen gage section and zero the output, or, attach the lead wires of the strain gages to the signal conditioner and zero the outputs. Ready the autograph data acquisition systems for data logging.

NOTE 10—If strain gages are used to monitor bending, zero the strain gages with the test specimen attached at only one end of the fixtures, that is, hanging free. This will ensure that bending due to the grip closure is factored into the measured bending.

9.3.3 Conducting the Test—Initiate the data acquisition. Initiate the test mode. After test specimen fracture, disable the action of the test machine and the data collection of the data acquisition system. Measure and report the breaking force to within $\pm 1.0\%$ of the load range. Carefully remove the test specimen from the grip interfaces. Take care not to damage the fracture surfaces by preventing them from contact with each other or other objects. Place the test specimen halves along with other fragments from the gage section into a suitable, non-metallic container for later analysis.

9.3.4 Determine the ambient temperature and relative humidity in accordance with Test Method E 337.

9.3.5 Post-Test Dimensions—Measure and report the fracture location if the gage section has not been overly fragmented by the fracture process. If an exact measure of the cross-sectional dimensions cannot be made due to fragmentation, use the average dimensions measured in 9.1.

9.3.5.1 Measure and report the fracture location relative to the midpoint of the gage section. Use the convention that the midpoint of the gage section is 0 mm with positive (+) measurements toward the top of the test specimen as tested (and marked) and negative (–) measurements toward the bottom of the test specimen as tested (and marked). For fracture surfaces which are not normal to the longitudinal axis and the actual fracture origin can not be ascertained, the average fracture location can be determined. Record and report the orientation of the fracture and fracture locations.

NOTE 11—Results from test specimens fracturing outside the uniformly stressed gage section are not recommended for use in the direct calculation

of a mean compressive strength at fracture for the entire test set. Results from test specimens fracturing outside the uniformly stressed gage section (that is, outside the ungripped gage length of straight-sided test specimens or outside the unsupported length of laterally-supported test specimens) are considered anomalous and can be used only as censored tests (that is, test specimens in which a compressive stress at least equal to that calculated by Eq 9 was sustained in the uniform gage section before the test was prematurely terminated by a non-gage section fracture). From a conservative standpoint in completing a required statistical sample (for example, $n=5$) for purposes of average strength, test one replacement test specimen for each test specimen that fractures outside the gage section.

9.3.5.2 In addition, test specimens fracturing at stresses greater than or equal to the calculated critical buckling stress are considered to have potentially failed from test specimen buckling and may not be representative of true uniaxial compressive strength (5, 6, 7, 10). Details of the determination of the critical buckling stress are contained in the appendix. Calculate the critical buckling stress from the simple Euler column buckling relation for fixed-end conditions such that:

$$\sigma_{cr} = \frac{P_{cr}}{wb} = \frac{4\pi^2 EI}{l^2 wb} \quad (5)$$

where: σ_{cr} is the Euler critical buckling stress; P_{cr} is the critical compressive force; w is the test specimen width; b is the test specimen thickness; π is pi; E is the longitudinal elastic modulus of the CFCC; I is the moment inertia in the b direction where $wb^3/12$; l is the actual, free (unsupported) length of the test specimen gage section.

Tendency to buckling can also be ascertained from strain gage information as noted in 6.4.2. In addition, an indication of anomalous behavior is if the strain values from the two opposite strain gages differ by more than 5 to 10 %. Treat test specimens fracturing at stresses greater than or equal to σ_{cr} or with strain values indicating anomalies in the test, or both, as specified in 9.3.5.2 for test specimens fracturing outside the gage section.

9.4 Fractography—Conduct visual examination and light microscopy, if necessary, to determine the mode and type of fracture (that is, brittle or fibrous). In addition, although quantitatively beyond the scope of this test method, subjective observations can be made of the length of the fiber pullout, orientation of fracture plane, degree of interlaminar fracture, and other pertinent details of the fracture surface. Fractographic examination of each failed test specimen is recommended to characterize the fracture behavior of CFCCs.

10. Calculation

10.1 General—Various types of CFCC materials, due to the nature and architecture of their constituents, processing routes, and prior mechanical history, may exhibit vastly different stress-strain responses as illustrated schematically in Fig. 8. Therefore, interpretation of the test results will depend on the type of response exhibited. Points corresponding to the following calculated values are shown on the appropriate diagrams.

10.2 Engineering Stress—Calculate the engineering stress as:

$$\sigma = \frac{P}{A} \quad (6)$$

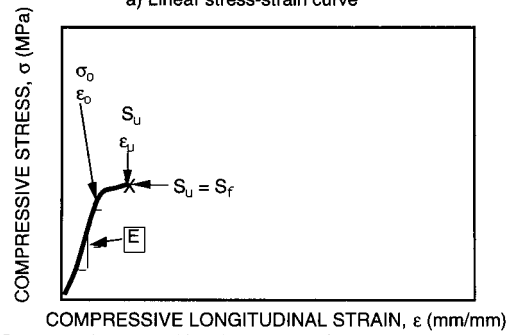
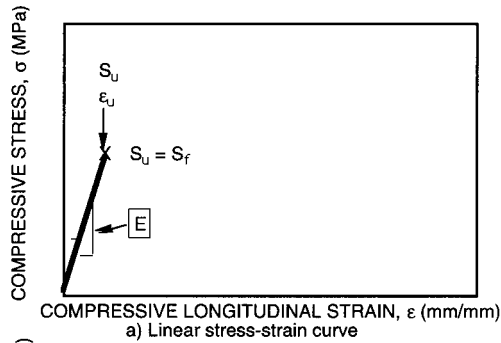

b) Stress-strain curve with a linear region followed by decreasing stiffness

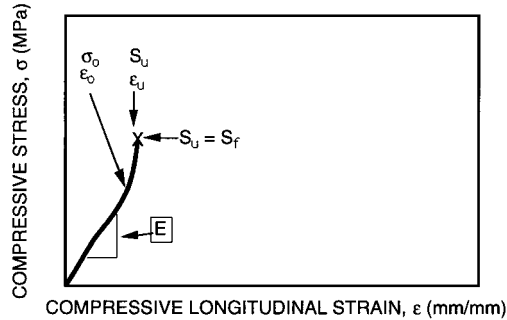

c) Stress-strain curve with a linear region followed by increasing stiffness

FIG. 8 Schematic Diagrams of Compressive Stress-Strain Curves for CFCCs

where:

- σ = engineering stress, MPa,
- P = applied, uniaxial compressive force, N, and
- A = original cross-sectional area, mm².

Calculate the cross-sectional area, A , as:

$$A = w b \text{ for rectangular cross sections} \quad (7)$$

where:

- w = average width of the gage section, mm, as detailed in 9.1 and 9.1.1, and
- b = average thickness of the gage section, mm, as detailed in 9.1 and 9.1.1.

10.3 *Engineering Strain*—Calculate the engineering strain as:

$$\epsilon = \frac{(I - I_o)}{I_o} \quad (8)$$

where:

- ϵ = engineering strain,
- I = extensometer gage length at any time, mm, and
- I_o = the original gage length of the extensometer, mm.

10.4 *Compressive Strength*—Calculate the compressive strength as:

$$S_u = \frac{P_{max}}{A} \quad (9)$$

where:

- S_u = the compressive strength, MPa, and
- P_{max} = the maximum force, N.

10.5 *Strain at Compressive Strength*—Determine strain at compressive strength, ϵ_u ; as the strain corresponding to the compressive strength measured during the test.

10.6 *Fracture Strength*—Calculate the fracture strength as:

$$S_f = \frac{P_{fracture}}{A} \quad (10)$$

where:

- S_f = compressive strength, MPa,
- $P_{fracture}$ = fracture force (breaking force) when the test specimen separates into two or more pieces, N, and in some instances,
- $S_u = S_f$

10.7 *Strain at Fracture Strength*—Determine strain at fracture strength, ϵ_f , as the engineering strain corresponding to the fracture strength measured during the test. In some instances, $\epsilon_u = \epsilon_f$.

10.8 *Modulus of Elasticity*—Calculate the modulus of elasticity as follows:

$$E = \frac{\Delta\sigma}{\Delta\epsilon} \quad (11)$$

where E is modulus of elasticity, and $\Delta\sigma/\Delta\epsilon$ is the slope of the $\sigma - \epsilon$ curve within the linear region as shown in Fig. 8. The modulus of elasticity may not be defined for materials which exhibit entirely non-linear $\sigma - \epsilon$ curves.

10.9 *Poisson's Ratio*— Calculate the Poisson's ratio (if transverse strain is measured) as follows:

$$\nu = \frac{\Delta\epsilon_T}{\Delta\epsilon_L} \quad (12)$$

where ν is Poisson's ratio, and $\Delta\epsilon_T/\Delta\epsilon_L$ is the slope of the linear region of the plot of transverse strain ϵ_T versus longitudinal strain, ϵ_L .

Poisson's ratio may not be defined for materials that exhibit nonlinear $\sigma - \epsilon$ curves over the entire history as shown in Fig. 8 (although this must be verified by plotting ϵ_T versus ϵ_L to determine whether or not a linear region exists).

10.10 *Proportional Limit Stress in Compression*— Determine the proportional limit stress, σ_o , by one of the following methods. By its definition the proportional limit stress, σ_o , may not be defined for materials which exhibit entirely linear $\sigma - \epsilon$ curves as shown in Fig. 8.

10.10.1 *Offset Method*— Determine σ_o by generating a line running parallel to the same part of the linear part of the $\sigma - \epsilon$ curve used to determine the modulus of elasticity in 10.8. The line so generated should be at a strain offset of 0.0005 mm/mm. The proportional limit stress is the stress level at which the offset line intersects the $\sigma - \epsilon$ curve (Fig. 9).

10.10.2 *Compression Under Force Method*—Determine σ_o by noting the stress on the $\sigma - \epsilon$ curve that corresponds to a

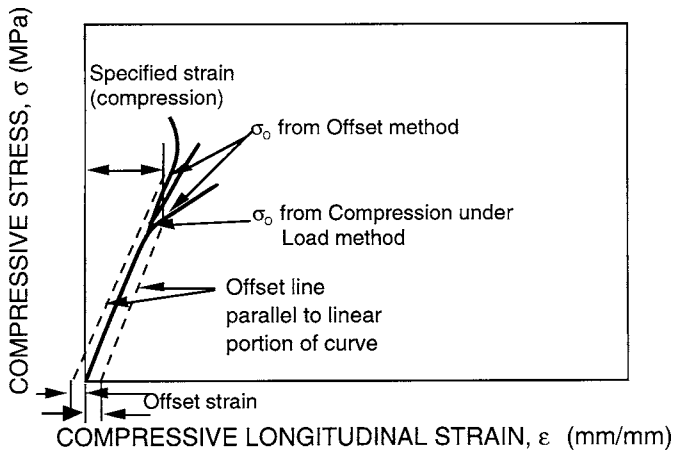

FIG. 9 Schematic Diagram of Methods for Determining Proportional Limit Stress in Compression

specified strain. The specified strain may or may not be in the linear region of the $\sigma - \epsilon$ but the specified strain at which σ_o is determined must be constant for all tests in a set with the specified strain reported.

10.11 *Strain at Proportional Limit Stress*—Determine strain, ϵ_o , at proportional limit stress in compression as the strain corresponding to proportional limit stress determined for the test.

10.12 *Mean Standard Deviation and Coefficient of Variation*—For each series of tests, the mean, standard deviation, and coefficient of variation for each measured value can be calculated as follows:

$$\text{Mean} = \bar{X} = \frac{\sum_{i=1}^n X_i}{n} \quad (13)$$

$$\text{Standard Deviation} = s.d. = \sqrt{\frac{\sum_{i=1}^n (X_i - \bar{X})^2}{n - 1}} \quad (14)$$

$$\text{Coefficient of variation} = V = \frac{100 (s.d.)}{\bar{X}} \quad (15)$$

where:

X_i = measured value and,
 n = number of valid tests.

11. Report

11.1 *Test Set*—Include in the report the following information for the test set. Note any significant deviations from the procedures and requirements of this test method.

11.1.1 Date and Location of Testing.

11.1.2 Compressive test specimen geometry used (include engineering drawing). For end-tabbed test specimens include a drawing of the tab and specify the tab material and the adhesive used.

11.1.3 Type and configuration of the test machine (include drawing or sketch if necessary). If a commercial test machine was used, the manufacturer and model number are sufficient

for describing the test machine. Good laboratory practice also dictates recording the serial numbers of the test equipment, if available.

11.1.4 Type, configuration, and resolution of strain measurement equipment used (include drawing or sketch if necessary). If a commercial extensometer or strain gages were used, the manufacturer and model number are sufficient for describing the strain measurement equipment. Good laboratory practice also dictates recording the serial numbers of the test equipment, if available.

11.1.5 Type and configuration of grip interface used (include drawing or sketch if necessary as well as surface finish of the interface). If a commercial grip interface was used, the manufacturer and model number are sufficient for describing the grip interface. Good laboratory practice also dictates recording the serial numbers of the test equipment, if available.

11.1.6 Type and configuration of load train couplers (include drawing or sketch if necessary). If a commercial load train coupler was used, the manufacturer and model number are sufficient for describing the coupler. Good laboratory practice also dictates recording the serial numbers of the test equipment, if available.

11.1.7 Number (n) of test specimens tested validly (for example, fracture in the gage section). In addition, report the total number of test specimens tested (n_T) to provide an indication of the expected success rate of the particular test specimen geometry and test apparatus.

11.1.8 Where feasible and possible, all relevant material data including vintage or billet identification. As a minimum, report the approximate date the material was manufactured.

11.1.8.1 For commercial materials, where feasible and possible, report the commercial designation. As a minimum include a short description of reinforcement (type, lay-up, etc.), fiber volume fraction, and bulk density.

11.1.8.2 For non-commercial materials, where feasible and possible, report the major constituents and proportions as well as the primary processing route including green state and consolidation routes. Also report fiber volume fraction, matrix porosity, and bulk density. Fully describe the reinforcement type, properties and reinforcement architecture to include fiber properties (composition, diameter, source, lot number and any measured/specified properties), interface coating (composition, thickness, morphology, source, and method of manufacture) and the reinforcement architecture (yarn type/count, thread count, weave, ply count, fiber areal weight, stacking sequence, ply orientations, etc.).

11.1.9 Description of the method of test specimen preparation including all stages of machining, cleaning, and storage time and method before testing.

11.1.10 Heat treatments, coating, or pre-test exposures, if any applied either to the as-processed material or the as-fabricated test specimen.

11.1.11 Test environment including relative humidity (Test Method E 337), ambient temperature and atmosphere (for example, ambient air, dry nitrogen, silicone oil, etc.).

11.1.12 Test mode (force, displacement, or strain control) and actual test rate (force rate, displacement rate, or strain rate). Report calculated strain rate, if appropriate, in s^{-1} .

11.1.13 Percent bending and corresponding average strain in the test specimen recorded during the verification as measured at the beginning and end of the test series.

11.1.14 Mean, standard deviation, and coefficient of variation of the following measured properties for each test series:

11.1.14.1 Critical Euler buckling stress for the nominal test geometry, σ_{cr} ,

11.1.14.2 Compressive strength, S_u ,

11.1.14.3 Strain at compressive strength, ϵ_u ,

11.1.14.4 Fracture strength in compression, S_f ,

11.1.14.5 Strain at fracture strength in compression, ϵ_f ,

11.1.14.6 Modulus of elasticity in compression, E (if applicable),

11.1.14.7 Poisson's ratio, ν (if applicable).

11.1.14.8 Proportional limit stress in compression σ_0 (if applicable) and method of determination, and

11.1.14.9 Strain at proportional limit stress in compression, ϵ_0 (if applicable).

11.2 *Individual Test Specimens*—Report the following information for each test specimen tested. Note and report any significant deviation from the procedures and requirements of this test method.

11.2.1 Pertinent overall test specimen dimensions, if measured, such as total length, length of gage section, gripped section dimensions, etc. in mm,

11.2.2 Average surface roughness of the gage section in μm , if measured, and the direction of measurement,

11.2.3 Average cross-sectional dimensions, if measured, or cross-sectional dimensions at the plane of fracture in mm,

11.2.4 Plot of the entire stress-strain curve,

11.2.5 Compressive strength, S_u ,

11.2.6 Strain at compressive strength, ϵ_u ,

11.2.7 Fracture strength in compression, S_f ,

11.2.8 Strain at fracture strength in compression, ϵ_f ,

11.2.9 Modulus of elasticity in compression, E (if applicable),

11.2.10 Poisson's ratio, ν (if applicable),

11.2.11 Proportional limit stress in compression, σ_0 (if applicable) and method of determination,

11.2.12 Strain at proportional limit stress in compression, ϵ_0 (if applicable),

11.2.13 Fracture location relative to the gage section midpoint in units of mm (+) is toward the top of the test specimen as marked and - is toward the bottom of the test specimen as marked with 0 being the gage section midpoint), See 9.3.5.1 for discussion of fracture location, and

11.2.14 Appearance of test specimen after fracture as suggested in 9.4.

12. Precision and Bias

12.1 Because of the nature of the materials and lack of a wide database on a variety of applicable CFCCs, no definitive statement can be made at this time concerning precision and bias of the test methods of this test method.

13. Keywords

13.1 ceramic matrix composite; CFCC; compression test; continuous fiber composite

APPENDIXES

(Nonmandatory Information)

X1. VERIFICATION OF LOAD TRAIN ALIGNMENT

X1.1 *Purpose of Verification*—The purpose of this verification procedure is to demonstrate that the grip interface and load train couplers can be used by the test operator in such a way as to consistently meet the limit on percent bending as specified in 6.5. Thus, this verification procedure shall involve no more care in setup than will be used in the routine testing of the actual compressive test specimen. Measure the bending under compressive force using verification (or actual) test specimens of exactly the same design as that to be used for the compressive tests. For the verification purposes, apply strain gages as shown in Fig. X1.1. Conduct verification measurements: at the beginning and end of a series of tests with a measurement at the midpoint of the series recommended, whenever the grip interfaces and load train couplers are installed on a different test machine, whenever a different operator is conducting a series of tests, and whenever damage or misalignment is suspected.

X1.2 *Verification Test Specimen*—Machine test specimens used for verification very carefully with attention to all tolerances and concentricity requirements. Ideally the verifica-

tion test specimen should be of identical material to that being tested. However, in the case of CFCCs, the type of reinforcement or degree of residual porosity may complicate the consistent and accurate measurement of strain. Therefore, an alternate material (isotropic, homogeneous, continuous) with similar elastic modulus, elastic strain capability, and hardness to the test material can be used. Carefully inspect the test specimen with an optical comparator before strain gages are attached to ensure that these dimensional requirements are met. After the strain gages are applied it will no longer be possible to meaningfully inspect the test specimen, so exercise care in handling and using it.

X1.2.1 For simplicity, mount a minimum of eight foil resistance strain gages on the verification test specimen as shown in Fig. X1.1. Separate the strain gage planes by $\sim 3/4 I_0$ where I_0 is the length of the reduced or designated gage section. Mount four strain gages, equally spaced (90° apart) around the circumference or the gage section (that is, one strain gage on each face), at each of two planes at either end of the gage section. Ensure that the longitudinal centers of all strain gages on the same plane are within 0.5 mm of the same

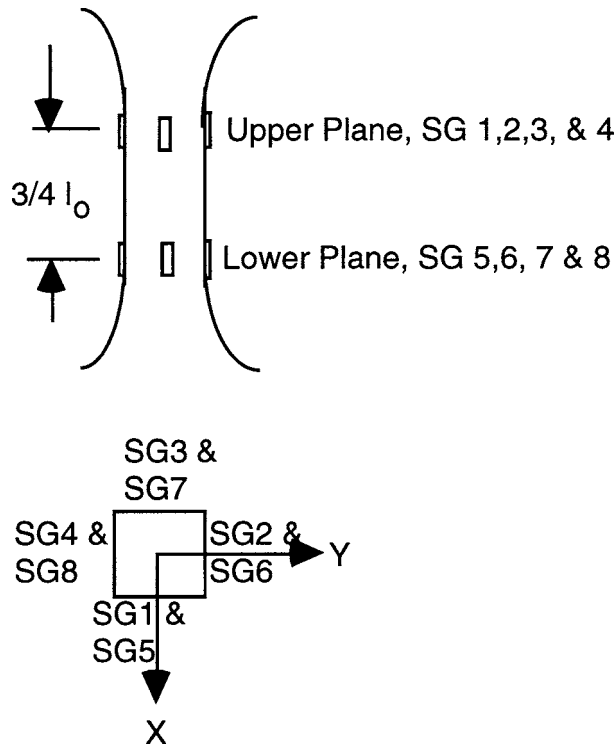

FIG. X1.1 Illustration of Strain Gage Placement on Gage Section Planes and Strain Gage Numbering

longitudinal distance along the test specimen axis. These planes shall be symmetrically located about the longitudinal midpoint of the gage section. Employ suitable strain recording equipment.

NOTE X1.1—Take care to select strain gage planes that are symmetrical about the longitudinal midpoint of the gage section. Avoid placing the strain gages closer than one strain gage length from geometrical features such as the transition radius from the gage section. Such placement can cause strain concentrations and inaccurate measures of the strain in the uniform gage section. Strain gages on dummy test specimens composed of isotropic homogeneous materials should be as narrow as possible to minimize strain averaging. Strain gages having active widths of 0.25 to 0.5 mm and active lengths of 1.0 to 2.5 mm are commercially available and are suitable for this purpose. Otherwise, strain gages on test specimens composed of CFCC materials should be of the size suggested in Note 3. Choose the strain gages, surface preparation, and bonding agents so as to provide adequate performance on the subject materials. Many CFCCs may exhibit high degrees of porosity and surface roughness and therefore require surface preparation including surface filling before the strain gages can be applied.

X1.3 Verification Procedure—Procedures for verifying alignment are described in detail in Practice E 1012. However, salient points and equations for square and circular cross-sections as currently contained in Practice E 1012 are described here for emphasis. Consult Practice E 1012 for specific details for rectangular cross-sections, especially when the thickness is too thin to strain gage all four sides. The following sections are not intended to replace Practice E 1012, but rather are intended to elucidate those aspects which are directly applicable to this particular test method.

X1.3.1 Mount the top of the test specimen in the grip interface.

X1.3.2 Connect the lead wires of the strain gages to the conditioning equipment and allow the strain gages to equilibrate under power for at least 30 min prior to conducting the verification tests. This will minimize drift during actual conduct of the verifications.

X1.3.3 Zero the strain gages before mounting the bottom of the test specimen in the grip interface. This will allow any bending due to the grips to be recorded.

X1.3.4 Mount the bottom of the test specimen in the grip interface.

X1.3.5 Apply a sufficient force to the test specimen to achieve a mean strain equal to either one half the anticipated strain at the onset of the cumulative fracture process (for example, matrix cracking stress) in the test material or a strain of -0.0005 (that is, -500 microstrain) whichever is greater. It is desirable to record the strain (and hence percent bending) as functions of the applied force to monitor any self alignment of the load train.

X1.3.6 Calculate percent bending at the upper plane of the gage section as follows for square cross sections referring to Fig. X1.1 for the strain gage numbers as follows:

$$PB_{upper} = \frac{\epsilon_b}{\epsilon_o} 100 \tag{X1.1}$$

$$\epsilon_b = \left[\left(\frac{\epsilon_1 - \epsilon_3}{2} \right)^2 + \left(\frac{\epsilon_2 - \epsilon_4}{2} \right)^2 \right]^{1/2} \tag{X1.2}$$

$$\epsilon_o = \frac{\epsilon_1 + \epsilon_2 + \epsilon_3 + \epsilon_4}{4} \tag{X1.3}$$

where ϵ_1 , ϵ_2 , ϵ_3 , and ϵ_4 are strain readings for strain gages located at the upper plane of the gage section. Strain gage readings are in units of strain (that is, m/m) and compressive strains are negative.

X1.3.7 Calculate percent bending at the lower plane of the gage section for square cross sections referring to Fig. X1.2 for the strain gage numbers as follows:

$$PB_{lower} = \frac{\epsilon_b}{\epsilon_o} 100 \tag{X1.4}$$

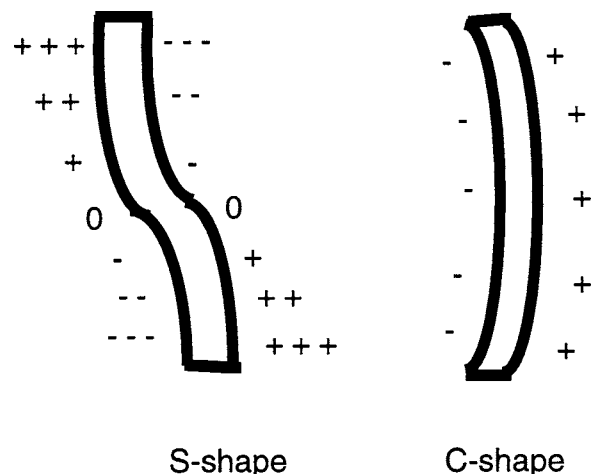

FIG. X1.2 S-Shape and C-Shape Bending of Compressive Test Specimen

$$\epsilon_b = \left[\left(\frac{\epsilon_5 - \epsilon_7}{2} \right)^2 + \left(\frac{\epsilon_6 - \epsilon_8}{2} \right)^2 \right]^{1/2} \quad (X1.5)$$

$$\epsilon_o = \frac{\epsilon_5 + \epsilon_6 + \epsilon_7 + \epsilon_8}{4} \quad (X1.6)$$

where $\epsilon_5, \epsilon_6, \epsilon_7,$ and ϵ_8 are strain readings for strain gages located at the lower plane of the gage section. Strain gage readings are in units of strain (that is, m/m) and compressive strains are negative.

X1.3.8 For uniform bending across the gage section with the test specimen assuming a C-shape, $PB_{upper} \approx PB_{lower}$. C-shape bending reflects angular misalignment of the grips. For non-uniform bending across the gage section with the test specimen assuming a S-shape, PB_{upper} may or may not be equal to PB_{lower} . S-shape bending reflects eccentric misalignment of the grip centerlines. These general tendencies are shown in Fig. X1.2. Combinations of C and S shapes may

exist. In these cases, eliminate the S-shape first by adjusting the concentricity of the grips such that the longitudinally aligned strain gages indicate approximately the same values (for example, $\epsilon_1 \approx \epsilon_5, \epsilon_2 \approx \epsilon_6,$ etc.). More detailed discussions regarding bending and alignment are contained in Ref. (11).

X1.3.9 Check the effect of the test specimen warpage by rotating the test specimen 180° about its longitudinal axis and performing the bending checks again. If similar results are obtained at each rotation then the degree of alignment can be considered representative of the load train and not indicative of the test specimen. If load train alignment is within the specifications of 6.5, record the maximum percent bending and conduct the compression tests. If the load train alignment is outside the specifications of 6.5 then align or adjust the load train according to the specific procedures unique to the individual testing setup. Repeat this verification procedure to confirm the achieved alignment.

X2. DETERMINATION OF COMPRESSION FORCE LIMITS AS A FUNCTION OF ELASTIC MODULUS AND TEST SPECIMEN THICKNESS TO ENSURE 'TRUE' COMPRESSIVE FAILURE

X2.1 *Purpose of Determination*—The limitations of the compression test as described in this test method are as follows. For exceedingly high-strength materials, irrespective of elastic modulus, the compression test is governed by the adhesive strength of the tabs or the interlaminar shear strength of the parent tab material. For low-elastic modulus materials, elastic column buckling may be critical.

X2.2 The most conservative assumption regarding behavior of a test specimen under axial compression is to assume that the test specimen behaves as a double-pinned-end column with one end free to move axially and length equal to the unsupported length in the test fixture. The more appropriate assumption for the case of frictional face-loaded grips and fixed load train couplers is a double-fixed-end column with one end free to move axially only and whose length is equal to one-fourth the unsupported length of the test fixture. For example, the test specimen illustrated in Fig. 5 has an untabbed gage length of 25 mm while the unsupported length (ungripped length) of the test specimen, which includes both the untabbed gage length and the tapered part of the end tabs, is ~38 mm.

X2.3 Assuming elastic behavior, the critical buckling stress for most conservative, pinned-end column is given as:

$$\sigma_e = \frac{P_e}{wb} = \frac{\pi^2 EI}{l^2 wb} \quad (X2.1)$$

where:

- σ_e = Euler critical buckling stress,
- P_e = critical compressive force,
- w = test specimen width,
- b = specimen thickness,
- π = pi,
- E = longitudinal elastic modulus of the CFCC,
- I = moment inertia in the b direction where $I = wb^3 / 12$, and

l = actual, free (unsupported) length of the test specimen gage section.

The critical buckling stress for the case of fixed-end column and $6 \leq w$ is given as:

$$\sigma_{cr} = \frac{P_{cr}}{wb} = \frac{4\pi^2 EI}{l^2 wb} \quad (X2.2)$$

where:

- σ_{cr} = critical buckling stress, and
- P_{cr} = critical compressive force.

X2.4 The critical stress of Eq X2.2 is shown in Fig. X2.1 for a recommended width of 10 mm but for a variety of thicknesses and elastic moduli. This figure shows whether the results of a test already performed are in the non-buckling force range, or for a given test specimen, whose moduli is known approximately from fiber or flexure properties, what upper force could be safely attained, and whether a thicker test

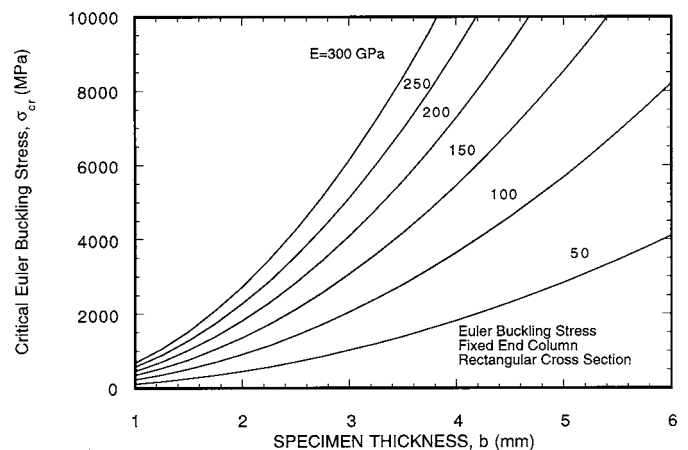

FIG. X2.1 Critical Euler Buckling Stress for Fixed-End Column With Rectangular Cross Section of Width 10 mm

specimen should be used.

X2.5 The axial shear stiffness of unidirectional composites is much lower than the axial stiffness. This can be accounted for by making a shear modulus correction resulting in a reduced critical buckling stress, σ_{cr}^{τ} , expressed as:

$$\sigma_{cr}^{\tau} = \frac{P_{cr}^{\tau}}{wb} = \frac{P_{cr}}{wb \left(1 + \frac{nP_{cr}}{wbG} \right)} \quad (X2.3)$$

where n is the shape factor ($n=1.2$ for rectangular cross sections) and G is the axial shear modulus. With this relationship, the expected critical buckling stress, σ_{cr}^{τ} , of Eq X2.3 is corrected upwards to the σ_{cr} of Fig. X2.1. This 'new' σ_{cr} is

then coupled with the expected CFCC compressive modulus to select from Fig. X1.2 the minimum test specimen thickness required to inhibit buckling.

X2.6 In most cases (Eq X2.2 and Eq X2.3, and Fig. X2.1), fixed-end columns are assumed. Since the end conditions in the recommended grips are closer to fixed end conditions than pinned end conditions, actual buckling forces will approach higher forces than predicted using the equations and figure. However, the more conservative criterion of pinned ends of Eq X2.1 nearly guarantees that compressive failure rather than column buckling will occur. When this criterion is exceeded, the only way to be certain that buckling does not occur is to use double strain gages as recommended in 6.4.2 and 9.3.

REFERENCES

- (1) Hartman G.A., Zawada, L.P., and Russ, S.M., "Techniques for Elevated Temperature Testing of Advanced Ceramic Composite Materials," *Proceedings of the Fifth Annual Hostile Environment and High Temperature Measurement Conference*, Society for Experimental Mechanics, Bethel, CT, 1988, pp. 31–38.
- (2) Mosiman, L.G., Wallenfelt, T.L., and Larsen, C.G., "Tension/Compression Grips for Monolithic Ceramics and Ceramic Matrix Composites," *Ceram. Eng. Scien. Proc.* 12 (7–8), (1991).
- (3) Jenkins M.G., Piccola, J.P. Jr., M.D. Mello, E. Lara-Curzio, and Wereszczak, A.A., "Mechanical Behaviour of a 3-D Braided, Continuous SiC Fiber-Reinforced / CVI SiC Matrix Composite at Ambient and Elevated Temperatures" *Ceram. Eng. Scien. Proc.* 15 (4), (1994), pp. 209–218.
- (4) Barnett, T.R., and Starrett, H.S., "Room and Elevated Temperature Mechanical and Thermal Properties of Corning Nicalon/CAS" *WRDC-TR-90-4131*, Wright Research and Development Center, Wright Patterson Air Force Base, OH, 1992.
- (5) Phillips, D.C., and Davidge R.W., "Test Techniques for the Mechanical Properties of Ceramic Matrix Fiber Composites," *Br. Ceram. Trans. J.*, 85, 1986, pp. 123–130.
- (6) Port, K.F. "The Compressive Strength of Carbon Fiber Reinforced Plastic," *Technical Report TR82083*, Royal Aircraft Establishment, Ministry of Defense, Farnborough, Hants, UK 1982.
- (7) Barker, A.J., and Balasundaram, V., "Compression Testing of Carbon Fiber-Reinforced Plastics Exposed to Humid Environments," *Composites*, 18 (3) (1987), 217–226.
- (8) Worthem, D.W., "Flat Tensile Specimen Design for Advanced Composites," *NASA CR-185261*, November 1990.
- (9) Shuler, S.F., and Holmes, J.W., Research Memorandum No. 102, September, 1990 "Influence of Loading Rate on the Monotonic Tensile Behavior of Fiber Reinforced Ceramics". Available through: Ceramic Composites Research Laboratory, Dept. of Mechanical Engineering and Applied Mechanics, 1065 GGBL, The University of Michigan, Ann Arbor, MI, 1990, 48109–2125.
- (10) Harper, J.F., Miller, N.A., Yap, S.C., "Problems Associated with the Compression Testing of Fiber Plastic Composites," in *Polymer Testing*, Elsevier Science Publishers Ltd., London, England, (1993), pp. 15–29.
- (11) Larsen, C.G., "Ceramics Tensile Grip," *STP 1080*, J.M. Kennedy, H.H. Moeller, and W.W. Johnson, eds., ASTM, 1990, pp. 235–246.

ASTM International takes no position respecting the validity of any patent rights asserted in connection with any item mentioned in this standard. Users of this standard are expressly advised that determination of the validity of any such patent rights, and the risk of infringement of such rights, are entirely their own responsibility.

This standard is subject to revision at any time by the responsible technical committee and must be reviewed every five years and if not revised, either reapproved or withdrawn. Your comments are invited either for revision of this standard or for additional standards and should be addressed to ASTM International Headquarters. Your comments will receive careful consideration at a meeting of the responsible technical committee, which you may attend. If you feel that your comments have not received a fair hearing you should make your views known to the ASTM Committee on Standards, at the address shown below.

This standard is copyrighted by ASTM International, 100 Barr Harbor Drive, PO Box C700, West Conshohocken, PA 19428-2959, United States. Individual reprints (single or multiple copies) of this standard may be obtained by contacting ASTM at the above address or at 610-832-9585 (phone), 610-832-9555 (fax), or service@astm.org (e-mail); or through the ASTM website (www.astm.org).