



Standard Test Method for Flow of Freshly Mixed Hydraulic-Cement Concrete¹

This standard is issued under the fixed designation C 1362; the number immediately following the designation indicates the year of original adoption or, in the case of revision, the year of last revision. A number in parentheses indicates the year of last reapproval. A superscript epsilon (ϵ) indicates an editorial change since the last revision or reapproval.

1. Scope*

1.1 This test method covers determination of the flow of a sample of freshly mixed concrete, either in the field or in the laboratory.

1.2 This test method is applicable to concrete having coarse aggregate up to 37.5 mm in size. If the coarse aggregate is larger than 37.5 mm in size, the test method is applicable when the fraction of concrete larger than 37.5 mm is removed in accordance with Practice C 172.

1.3 The values stated in SI units are the standard.

1.4 The text of this standard references notes and footnotes that provide explanatory information. These notes and footnotes (excluding those in tables and figures) shall not be considered as requirements of this standard.

1.5 *This standard does not purport to address all of the safety concerns, if any, associated with its use. It is the responsibility of the user of this standard to establish appropriate safety and health practices and determine the applicability of regulatory limitations prior to use. (Warning—Fresh hydraulic cementitious mixtures are caustic and may cause chemical burns to skin and tissue upon prolonged exposure.²)*

2. Referenced Documents

2.1 *ASTM Standards:*³

C 172 Practice for Sampling Freshly Mixed Concrete

C 670 Practice for Preparing Precision and Bias Statements for Test Methods for Construction Materials

3. Summary of Test Method

3.1 A flow apparatus comprising an outer partially perforated hollow tube and an inner calibrated floating rod is inserted into a sample of freshly mixed concrete to a preset level and held in place by a collar floater. A portion of the

concrete is allowed to flow into the hollow tube through its perforations for a period of 40 s. The inner floating rod is then lowered onto the concrete surface that has penetrated the hollow tube. The height of the concrete in the hollow tube is read from the scale on the upper portion of the floating rod protruding from the top of the hollow tube. With increasing fluidity of the concrete a higher flow reading is obtained on a scale from zero to one hundred divisions.

4. Significance and Use

4.1 This test method permits a rapid assessment of the flow and consistency of freshly mixed concrete (see Note 1).

4.2 This test method also provides information on the change in flow and consistency with time of concrete containing superplasticizer admixtures.

4.3 This test method can be used to measure the uniformity characteristics of flow and consistency of freshly mixed concrete and its change with time.

NOTE 1—This test method may not be appropriate for use in evaluating gap-graded aggregate concrete.

5. Apparatus

5.1 Details of the apparatus are shown in Fig. 1. The apparatus consists of (1) measuring rod, (2) scale datum, (3) hollow tube with round holes and longitudinal slots, (4) holding pin, (5) collar floater, and (6) tube point.

5.2 Measuring rod is a hollow tube, 13 mm in outside diameter, 336 mm long with a wall thickness of 1.5 mm and it is capped at both ends with a cap 15 mm in outside diameter. A scale datum is 45 mm in outside diameter and 25 mm wide and fabricated to fit hollow tube and accommodate measuring rod. Hollow tube has an outside diameter of 33 mm, and it is 310 mm long with a wall thickness of 4 mm and has 16 round holes, 9.4 mm in diameter, and 4 longitudinal slots, 9.4 mm wide by 50 mm long, which are distributed around the circumference of the tube as shown in Fig. 1. A pin which is a rivet, 3.2 mm in diameter, protrudes 3.2 mm inside tube. Collar floater, made of a plate 5 mm thick, has an outside diameter of 90 mm and inside diameter of 33 mm, is connected to hollow tube. Tube point is machined from a rod stock and fashioned into a conical shape. It is secured to the bottom end of hollow tube, and it is used to facilitate the insertion of the assembly into the fresh concrete. All individual dimensions shall have a

¹ This test method is under the jurisdiction of ASTM Committee C09 on Concrete and Concrete Aggregates and is the direct responsibility of Subcommittee C09.60 on Testing Fresh Concrete.

Current edition approved June 1, 2004. Published June 2004. Originally approved in 1997. Last previous edition approved in 1997 as C 1362–97(2002).

² Section on Safety Precautions, Manual of Aggregate and Concrete Testing, *Annual Book of ASTM Standards*, Vol 04.02

³ For referenced ASTM standards, visit the ASTM website, www.astm.org, or contact ASTM Customer Service at service@astm.org. For *Annual Book of ASTM Standards* volume information, refer to the standard's Document Summary page on the ASTM website.

*A Summary of Changes section appears at the end of this standard.

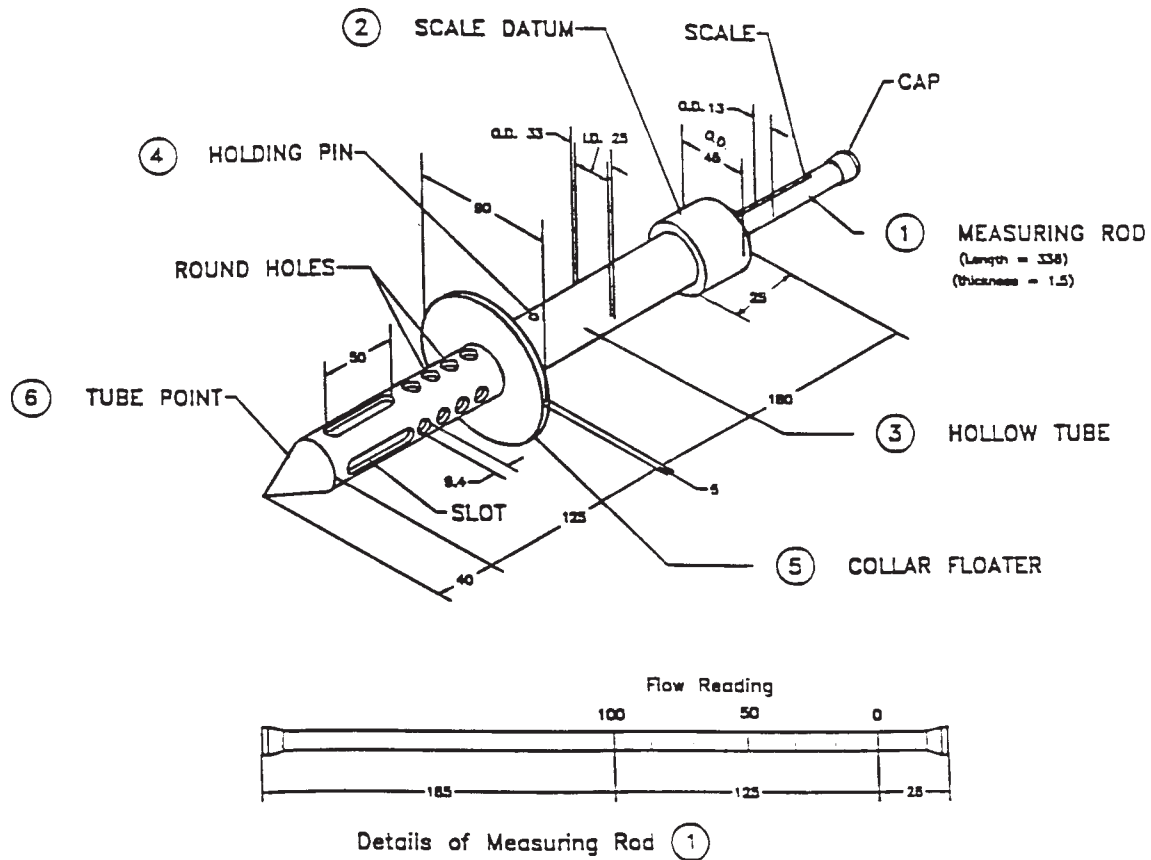

All dimensions in millimetres
(1 in. = 25.4 mm)

FIG. 1 Apparatus for Flow Test

tolerance of $\pm 1\%$ of their value. Make all parts of the apparatus of non-corrosive materials that are not affected by chemicals found in the fresh concrete.

6. Sampling

6.1 Determine the flow either as the concrete is placed in the forms prior to any manipulation or in a suitable container such as a can, a hopper, a pail, or a wheelbarrow. The sample of concrete from which determination of flow is made shall be representative of the entire batch. Obtain the sample in accordance with the requirements of Practice C 172.

7. Procedure

7.1 Bring the surface of the concrete to a smooth and level condition. Use a small wood float or screed, but work the surface as little as possible to avoid formation of mortar layers. The minimum depth of concrete at testing shall be 175 mm, and the distance from the tube to the nearest edge of the level surface of the concrete on which the flow or consistency is to be determined shall be a minimum of 75 mm. During the flow measurement protect the concrete against vibration, jarring, or agitation. Wet the apparatus, and shake off all excess water. Raise the measuring rod, and let it rest on the pin inside the apparatus. Insert the apparatus slowly and vertically downward

until the collar floater rests at the surface of the concrete. Do not rotate the apparatus while inserting it into the concrete. After 40 s of complete insertion lower the measuring rod slowly until it rests on the surface of the concrete that entered into the hollow tube. Read and record the level of the measuring rod to the nearest division in percent on the scale which represents the flow of the concrete.

8. Report

8.1 Record the flow in terms of the number of divisions of 1 % on the scale; if more than one test reading is taken on the same concrete, report the average to the nearest division in percent.

9. Precision and Bias ⁴

9.1 *Precision*—Based on data from 150 tests, with a flow of 10 to 90 % the pooled standard deviation is 8 %⁴ for a single operator using the same test device. Therefore, the range of two tests on the same material should not exceed 23 %.⁴

⁴ Supporting data have been filed at ASTM International Headquarters and may be obtained by requesting Research Report RR: C09-1011.

NOTE 2—These numbers represent, respectively, the (1 s %) and (d2s %) limits as defined in Practice C 670.

9.2 *Bias*—This test method has no bias because the values determined can be defined only in terms of this test method.

10. Keywords

10.1 concrete; consistency; flow; fluidity; fresh concrete; uniformity

SUMMARY OF CHANGES

Committee C09 has identified the location of selected changes to this test method since the last issue, C 1362 – 97(2002), that may impact the use of this test method. (Approved June 1, 2004)

(1) Editorial correction to the title.
(2) New section 1.4 concerning notes.

(3) Renumbered section 1.5 with addition of safety caveat.

ASTM International takes no position respecting the validity of any patent rights asserted in connection with any item mentioned in this standard. Users of this standard are expressly advised that determination of the validity of any such patent rights, and the risk of infringement of such rights, are entirely their own responsibility.

This standard is subject to revision at any time by the responsible technical committee and must be reviewed every five years and if not revised, either reapproved or withdrawn. Your comments are invited either for revision of this standard or for additional standards and should be addressed to ASTM International Headquarters. Your comments will receive careful consideration at a meeting of the responsible technical committee, which you may attend. If you feel that your comments have not received a fair hearing you should make your views known to the ASTM Committee on Standards, at the address shown below.

This standard is copyrighted by ASTM International, 100 Barr Harbor Drive, PO Box C700, West Conshohocken, PA 19428-2959, United States. Individual reprints (single or multiple copies) of this standard may be obtained by contacting ASTM at the above address or at 610-832-9585 (phone), 610-832-9555 (fax), or service@astm.org (e-mail); or through the ASTM website (www.astm.org).