



# Standard Test Method for Dead Load Resistance of a Sealant in Elevated Temperatures<sup>1</sup>

This standard is issued under the fixed designation C 1367; the number immediately following the designation indicates the year of original adoption or, in the case of revision, the year of last revision. A number in parentheses indicates the year of last reapproval. A superscript epsilon ( $\epsilon$ ) indicates an editorial change since the last revision or reapproval.

## 1. Scope

1.1 This test method covers a laboratory procedure for determining the heat resistance of sealants. This test method is conducted under dead load in a shear mode. This test method was previously written to include only hot applied sealants.

1.2 The values stated in SI units are to be regarded as the standard. The values given in parentheses are provided for information purposes only.

1.3 *This standard does not purport to address all of the safety concerns, if any, associated with its use. It is the responsibility of the user of this standard to establish appropriate safety and health practices and determine the applicability of regulatory limitations prior to use.*

1.4 The subcommittee with jurisdiction of this standard is not aware of any similar or equivalent ISO standard.

## 2. Referenced Documents

2.1 *ASTM Standards:*<sup>2</sup>

**B 209** Specification for Aluminum and Aluminum-Alloy Sheet and Plate

**C 717** Terminology of Building Seals and Sealants

**C 1036** Specification for Flat Glass

**C 1375** Guide for Substrates Used in Testing Building Seals and Sealants

## 3. Terminology

3.1 *Definitions*—Definitions of the following terms used in this test method are found in Terminology **C 717**, 4.1: adhesive failure, cohesive failure, hot-applied sealant, sealant, and substrate.

3.2 *Definitions of Terms Specific to This Standard*—Definitions of the following terms used in this test method are found in Terminology **C 717**, 4.2: applicator and specified temperature.

<sup>1</sup> This test method is under the jurisdiction of ASTM Committee C24 on Building Seals and Sealants and is the direct responsibility of Subcommittee C24.30 on Adhesion.

Current edition approved Sept. 1, 2006. Published September 2006. Originally approved in 1997. Last previous edition approved in 2001 as C 1367–01.

<sup>2</sup> For referenced ASTM standards, visit the ASTM website, [www.astm.org](http://www.astm.org), or contact ASTM Customer Service at [service@astm.org](mailto:service@astm.org). For *Annual Book of ASTM Standards* volume information, refer to the standard's Document Summary page on the ASTM website.

## 4. Summary of Test Method

4.1 The sealant is placed between glass and aluminum substrates. The specimen conditioning time is recorded. The specimen is heated in shear mode with a weight suspended from the specimen. The weight applied and the time that it takes for the specimen to fail is recorded.

## 5. Significance and Use

5.1 Sealants are generally subjected to stresses in end-use applications. This test method measures the heat resistance of sealants when subjected to dead load shear stresses while under heat.

## 6. Apparatus

6.1 *Sealant Applicator or Oven*, capable of maintaining the sealant within  $\pm 2.8^\circ\text{C}$  ( $\pm 5^\circ\text{F}$ ) of the specified temperature.

6.2 *Substrates:*

6.2.1 Annealed glass that is 25.4 mm wide by 76.2 mm long and 6.35 mm thick (1 in. by 3 in. by 0.25 in.). (See Specification **C 1036**.)

6.2.2 Aluminum alloy 5052-H32 that is 25.4 mm wide by 76.2 mm long and 0.508 mm thick (1 in. by 3 in. by 0.020 in.). (See Specification **B 209**.)

6.2.3 Other substrates may be used when specified (**Fig. 1**).

6.3 *Template*, to provide 3.28-mm ( $\frac{1}{8}$ -in.) sealant thickness (**Fig. 2**).

6.4 *Hot Knife or Spatula*.

6.5 *Test Oven*, capable of maintaining specified temperature within  $\pm 2.8^\circ\text{C}$  ( $\pm 5^\circ\text{F}$ ). This oven must contain some apparatus for suspending the specimens in shear mode during testing. Automatic timing devices and recorders may be used to record the time it takes for the test specimens to shear apart.

## 7. Sampling

7.1 Sealant shall be free of external surface contaminants such as talc, oil, dust, and moisture. Handling of the sealant surfaces in contact with the substrate shall be minimized.

7.2 Condition not less than 250 g of sealant (and sufficient portion of other components, if a multicomponent) in a closed container for 24 h at  $23 \pm 2^\circ\text{C}$  ( $73.4 \pm 3.6^\circ\text{F}$ ) and  $50 \pm 5\%$  relative humidity.

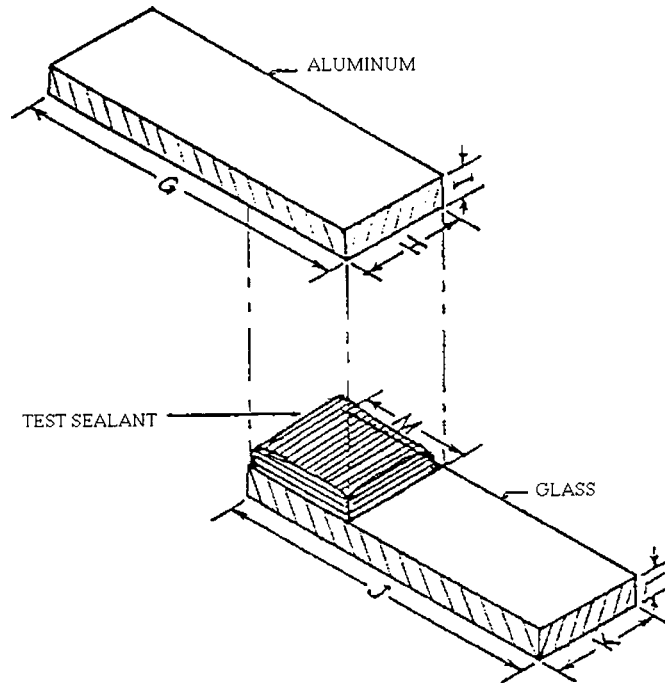

Dimension	Length	
	mm	in.
G, J	$76.2 \pm 0.25$	$(3.00 \pm 0.01)$
H, K, M	$25.4 \pm 0.25$	$(1.00 \pm 0.01)$
I	$0.635 \pm 0.127$	$(0.025 \pm 0.005)$
!	$6.35 \pm 0.76$	$(0.250 \pm 0.030)$

FIG. 1 Assembly of Test Sealant on Substrates

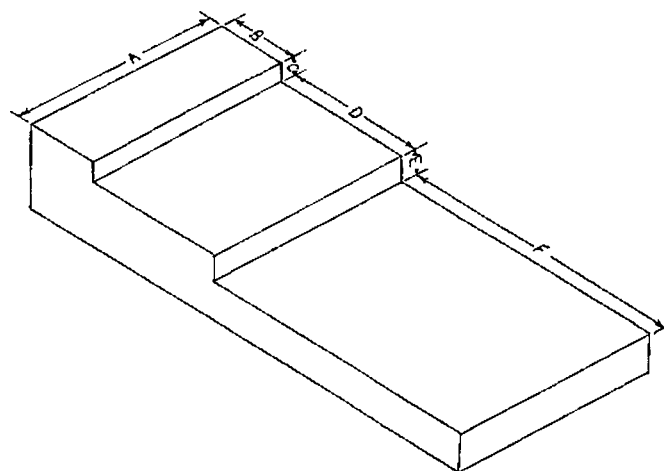

Dimension	Length	
	mm	in.
A	$76.2 \pm 5$	$(3.00 \pm 0.20)$
B	over 12.7	(over 0.50)
C	$6.35 \pm 0.25$	$(0.25 \pm 0.01)$
D	$50.8 \pm 0.25$	$(2.00 \pm 0.01)$
E	$8.89 \pm 1.02$	$(0.35 \pm 0.84)$
F	over 76.2	(over 3.00)

NOTE 1—The template shall be made of a material of low thermal conductivity, such as wood or fiberglass.

FIG. 2 Template

## 8. Test Specimens

8.1 Prepare five test specimens from the bulk sample by using the applicator or oven method.

### 8.1.1 Applicator Method:

8.1.1.1 Clean the glass and aluminum surfaces according to the procedures set forth in Guide C 1375.

8.1.1.2 Using the appropriate die or nozzle, apply a 25.4 by 25.4-mm (1 by 1-in.) layer of sealant onto one end of the glass surface at a thickness that when compressed will comply with 8.1.1.4. All substrates shall be at a temperature of  $23 \pm 2^\circ\text{C}$  ( $73.4 \pm 3.6^\circ\text{F}$ ). Apply the sealant at the temperature specified by the sealant manufacturer.

8.1.1.3 Immediately after sealant application, place the aluminum substrate onto the sealant to form an overlap of  $6.45 \text{ cm}^2$  ( $1 \text{ in.}^2$ ) (Fig. 1).

8.1.1.4 Using a template (Fig. 2), compress the overlaid sealant to form a 3.18-mm ( $1/8$ -in.) thick overlap (Fig. 3).

8.1.1.5 Remove excess sealant from the specimen with a hot knife or spatula.

8.1.2 *Oven Method:*

8.1.2.1 Clean the glass surface according to the procedures set forth in Guide C 1375.

8.1.2.2 Place sufficient sealant onto the substrate so that when compressed, a  $6.45\text{-cm}^2$  ( $1\text{-in.}^2$ ) overlap that will comply with 8.1.2.5 is obtained.

8.1.2.3 Clean the aluminum substrate according to the procedures set forth in Guide C 1375.

8.1.2.4 Separately place both the glass with sealant and the overlapping aluminum into an oven and condition for 30 min at the specified application temperature.

8.1.2.5 Immediately upon removing the substrates from the oven, place the aluminum substrate onto the sealant over the glass substrate (Fig. 1). Using the template (Fig. 2), compress the overlaid sealant to form a 3.18-mm ( $1/8$ -in.) thick overlap (Fig. 3).

8.1.2.6 Remove excess sealant from the specimen with a hot knife or spatula.

8.2 When the specimens are ready to handle, either because they have cooled or have been allowed to cure at specified conditions, cover the end of the glass substrate with several layers of masking tape. Press the tape firmly onto the glass. Cut small rectangular areas out of the tape so that the glass substrate can be seen.

8.3 When the specimens are ready for testing, prepare the aluminum end to hold a 500-g (1.10-lb) weight for the duration of the test. This can be done by drilling or punching a hole at the end of the aluminum substrate (centering the hole). This hole is used for suspending the 500-g test weight. Alternatively, the end can be punched to create a raised surface or otherwise modified to allow suspension of the weight.

9. Conditioning

9.1 Condition all test specimens at  $23 \pm 2^\circ\text{C}$  ( $73.4 \pm 3.6^\circ\text{F}$ ) and  $50 \pm 10\%$  relative humidity for at least 24 h prior to testing.

9.2 Additional conditioning may be done as specified by mutual agreement between the purchaser and sealant manufacturer.

10. Procedure

10.1 Suspend the glass end of the specimen in the oven set at the specified test temperature  $\pm 2.8^\circ\text{C}$  ( $\pm 5^\circ\text{F}$ ). Clips can be attached to the glass (over the cut out rectangle) and suspended from the top of the oven. Clamps may also be used or any device that allows the specimens to hang vertically during the test.

10.2 Attach a 500-g (1.10-lb) weight to the aluminum end of the specimen. Some weights have hooks permanently attached. Alternatively, any device that allows the weight to hang vertically during the test may be used.

10.3 Close the oven door and maintain the specified test temperature for the duration of the test.

10.4 Record the time in minutes to shear failure of the specimens.

10.5 Examine the shears and record the type of failure, adhesive or cohesive, and percentage of each.

NOTE 1—The oven must be at the specified test temperature before suspending specimens. The specimens should be suspended as quickly as

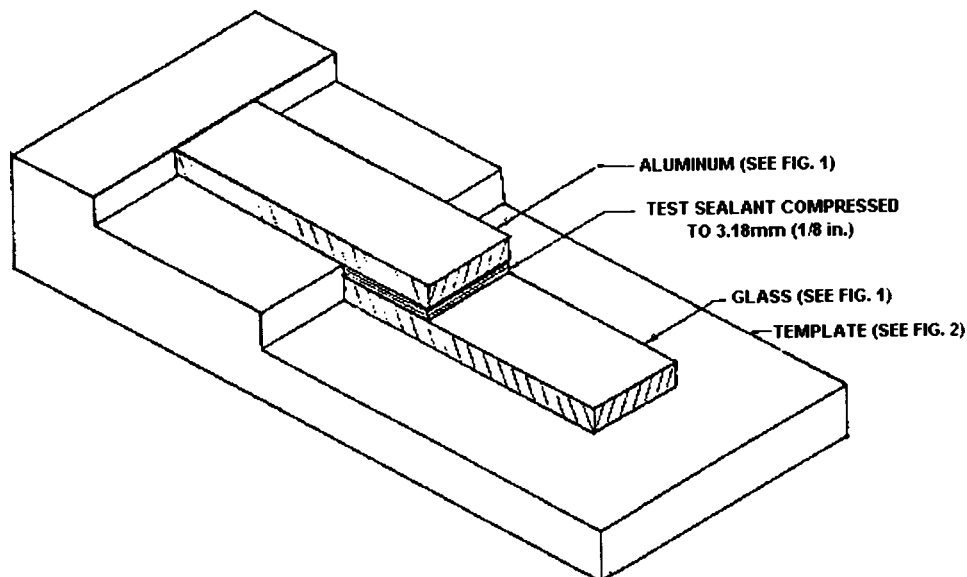

FIG. 3 Test Assembly on Template After Compression

possible to avoid excessive heat loss. The oven should be monitored to ensure that the specified test temperature is maintained for the duration of this test method.

## 11. Report

11.1 Report the following information:

- 11.1.1 Sealant name and any other identifying characteristics,
- 11.1.2 Equipment used to apply the sealant,
- 11.1.3 Specified test temperature and load applied,
- 11.1.4 Average time to failure in minutes,
- 11.1.5 Type of failure, adhesive or cohesive, and percentage of each,
- 11.1.6 Any substrate deformation during testing and the degree of deformation,
- 11.1.7 Sealant application temperature,
- 11.1.8 Oven temperature and time of conditioning,
- 11.1.9 Substrates tested,
- 11.1.10 Substrate cleaning procedure, and
- 11.1.11 Any additional conditioning as allowed by 9.2.

## 12. Precision and Bias

12.1 The precision and bias of this test method are based on data obtained from four laboratories using aluminum and glass substrates and three sealants. Both applicator and oven methods were used and the mode of failure on all samples was cohesive.

12.2 The repeatability (within a given laboratory) interval for three materials tested by four laboratories is 4.314 min. In future use of this test method, the difference between two test results obtained in the same laboratory on the same material will be expected to exceed 4.314 min only about 5 % of the time.

12.3 The reproducibility (between given laboratories) interval for three materials tested by four laboratories is 31.562 min. In future use of this test method, the difference between two test results obtained in a different laboratory on the same material will be expected to exceed 31.562 min only about 5 % of the time.

## 13. Keywords

- 13.1 dead load shear; heat resistance; time to failure

*ASTM International takes no position respecting the validity of any patent rights asserted in connection with any item mentioned in this standard. Users of this standard are expressly advised that determination of the validity of any such patent rights, and the risk of infringement of such rights, are entirely their own responsibility.*

*This standard is subject to revision at any time by the responsible technical committee and must be reviewed every five years and if not revised, either reapproved or withdrawn. Your comments are invited either for revision of this standard or for additional standards and should be addressed to ASTM International Headquarters. Your comments will receive careful consideration at a meeting of the responsible technical committee, which you may attend. If you feel that your comments have not received a fair hearing you should make your views known to the ASTM Committee on Standards, at the address shown below.*

*This standard is copyrighted by ASTM International, 100 Barr Harbor Drive, PO Box C700, West Conshohocken, PA 19428-2959, United States. Individual reprints (single or multiple copies) of this standard may be obtained by contacting ASTM at the above address or at 610-832-9585 (phone), 610-832-9555 (fax), or service@astm.org (e-mail); or through the ASTM website (www.astm.org).*