



Standard Specification for Bent Glass¹

This standard is issued under the fixed designation C 1464; the number immediately following the designation indicates the year of original adoption or, in the case of revision, the year of last revision. A number in parentheses indicates the year of last reapproval. A superscript epsilon (ϵ) indicates an editorial change since the last revision or reapproval.

1. Scope

1.1 This specification covers the requirements for bent glass used in general building construction, furniture, display, and various other non-automotive applications.

1.2 The dimensional values, stated in SI units are to be regarded as the standard. The values given in parentheses are provided for information only.

1.3 The following safety hazards caveat pertains only to the test method portion, Section 7, of this specification. *This standard does not purport to address all of the safety concerns, if any, associated with its use. It is the responsibility of the user of this standard to establish appropriate safety and health practices and determine the applicability of regulatory limitations prior to use.*

2. Referenced Documents²

2.1 ASTM Standards:³

- C 162 Terminology of Glass and Glass Products
- C 1036 Specification for Flat Glass
- C 1048 Specification for Heat-Treated Flat Glass—Kind HS, Kind FT Coated and Uncoated Glass
- C 1172 Specification for Laminated Architectural Flat Glass
- C 1422 Specification for Chemically Strengthened Flat Glass

2.2 Federal Document:⁴

- CPSC 16 CFR 1201 Consumer Product Safety Commission Safety Standard for Architectural Glazing Material

3. Terminology

3.1 *Definitions*—Refer to Terminology C 162, Specifications C 1036, C 1422, and C 1172, as appropriate.

3.1.1 *Blemishes in Flat Glass*—Refer to Specifications C 1036, C 1048, C 1422, and C 1172, as appropriate.

3.2 Definitions of Terms Specific to This Standard:

3.2.1 *bent glass, n*—flat glass that has been shaped while hot into a body having curved surfaces.

3.2.2 *chord, n*—a straight line segment that joins two points of an arc.

3.2.3 *compound bend, n*—a profile shape composed of curvature of one or more radii, curved on two or more axes.

3.2.4 *crossbend, n*—deviation from a straight edge along a line perpendicular to the curvature measured on the concave side.

3.2.5 *cylindrical bend, n*—a profile shape composed of a single curvature with a constant radius and no straight sections, all curved on a single axis.

3.2.6 *degree of angle, n*—the angular measurement of a segment of a curve.

3.2.7 *depth, n*—on a circular bend, the distance from the midpoint of a chord to the arc measured along its radius perpendicular to the circumference.

3.2.8 *elliptical bend, n*—a curved profile shape composed of two or more tangential radii on a single axis.

3.2.9 *girth, n*—the distance around the concave or convex surface measured perpendicular to the height including any flats.

3.2.10 *height, n*—the length measurement of the edge perpendicular to the horizontal arc or girth.

3.2.11 *multiple bend, n*—a profile shape composed of a curvature of two or more radii, all curved on a single axis, with at least two of the curvatures possibly separated by a flat (plane) area, and with or without one or more additional flat (plane) areas tangent to the curvatures.

3.2.12 *pock marks, n*—process surface blemishes that consist of small, shallow areas, circular in shape, on the surface of the glass.

3.2.13 *Ring marks*—process surface blemishes that consist of shallow marks typically running along the perimeter of the glass surface.

3.2.14 *Rotation*—a condition where vertical edges (perpendicular to arc) are not parallel to bending axis.

3.2.15 *Serpentine bend*—profile shape composed of concave and convex curvatures of one or more radii on a single axis with or without flat areas tangent to the curvatures.

¹ This specification is under the jurisdiction of ASTM Committee C14 on Glass and Glass Products and is the direct responsibility of Subcommittee C14.08 on Flat Glass.

Current edition approved April 1, 2006. Published April 2006. Originally approved in 2000. Last previous edition approved in 2000 as C 1464-00.

² Reference to these standards shall be the latest revision unless otherwise specified by the authority applying this specification.

³ For referenced ASTM standards, visit the ASTM website, www.astm.org, or contact ASTM Customer Service at service@astm.org. For *Annual Book of ASTM Standards* volume information, refer to the standard's Document Summary page on the ASTM website.

⁴ Available from the Superintendent of Documents, U.S. Government Printing Office, Washington, DC 20402.

3.2.16 *Shape*—contoured form including curvature, arc(s), and even flats.

3.2.17 *Single bend*—a profile composed of a single radius curved on a single axis, possibly with one or two flat (plane) areas tangent to the curvature.

3.2.18 *Twist*—one or more of the corners of the glass are not in the same plane.

4. Classification

4.1 *Kinds*—Bent glass furnished under this specification shall be of the following kinds, as specified:

4.1.1 *Kind BA*—Bent glass shall be annealed flat glass, either transparent, patterned, or wired glass in accordance with the applicable requirements of Specification C 1036, as further processed to conform with the requirements hereinafter specified for bent glass.

4.1.2 *Kind BCS*—Chemically strengthened bent glass shall be flat glass, either transparent or patterned, in accordance with the applicable requirements of Specification C 1036, as further processed to conform with the requirements hereinafter specified for bent glass and in accordance with the applicable requirements of Specification C 1422 for chemically strengthened flat glass.

4.1.3 *Kind BFT*—Fully tempered bent glass shall be flat glass, either transparent or patterned, in accordance with the applicable requirements of Specification C 1036, as further processed to conform with the requirements hereinafter specified for bent glass and in accordance with the applicable requirements of Specification C 1048 for fully tempered glass.

4.1.4 *Kind BHS*—Heat-strengthened bent glass shall be flat glass, either transparent or patterned, in accordance with the applicable requirements of Specification C 1036, as further processed to conform with the requirements hereinafter speci-

fied for bent glass and in accordance with the applicable requirements of Specification C 1048 for heat-strengthened glass.

4.1.5 *Kind BL*—Laminated bent glass shall be flat glass, either transparent or patterned, in accordance with the applicable requirements of Specification C 1036 as further processed with the requirements hereinafter specified for bent glass and in accordance with the applicable requirements of Specification C 1172 for laminated glass.

4.1.6 *Kind BX*—Bent glass with miscellaneous combinations not previously combined.

5. Ordering Information

5.1 Purchasers should include the following information in procurement documents:

5.1.1 Title, number, and date of this specification.

5.1.2 Kind of bent glass as referred to in this specification (see Section 4).

5.1.3 Fabrication requirements (see Section 6).

5.1.4 *Thickness Requirements:*

5.1.4.1 Overall thickness designation.

5.1.4.2 Thickness of individual lites in the laminate.

5.1.4.3 Interlayer thickness and type.

5.1.5 Nominal height, width, radius (see definitions and Figs. 1-3).

5.1.5.1 Blackline or blue-line prints, drawing, template, configuration, specification, or other forms of information which detail overall size, type of bend, and orientation.

5.1.6 Safety standards or regulations to which the glass must conform.

5.1.7 *Packaging Requirements*—Glass packaging and protection will be standard manufacturer practice unless otherwise specified. Consult manufacturer before specifying.

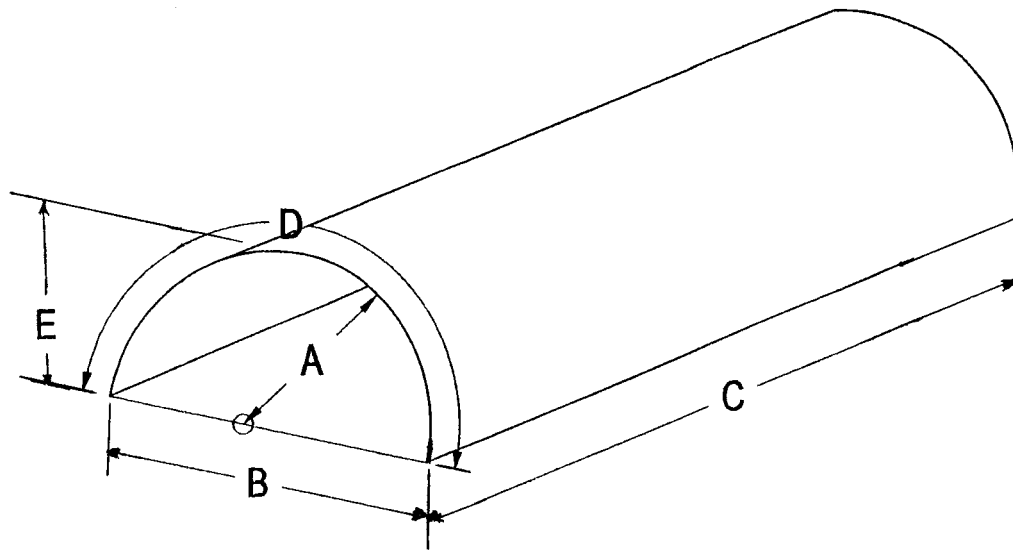

- A = outside radius
- B = chord
- C = height
- D = girth
- E = depth

FIG. 1 Cylindrical Bend

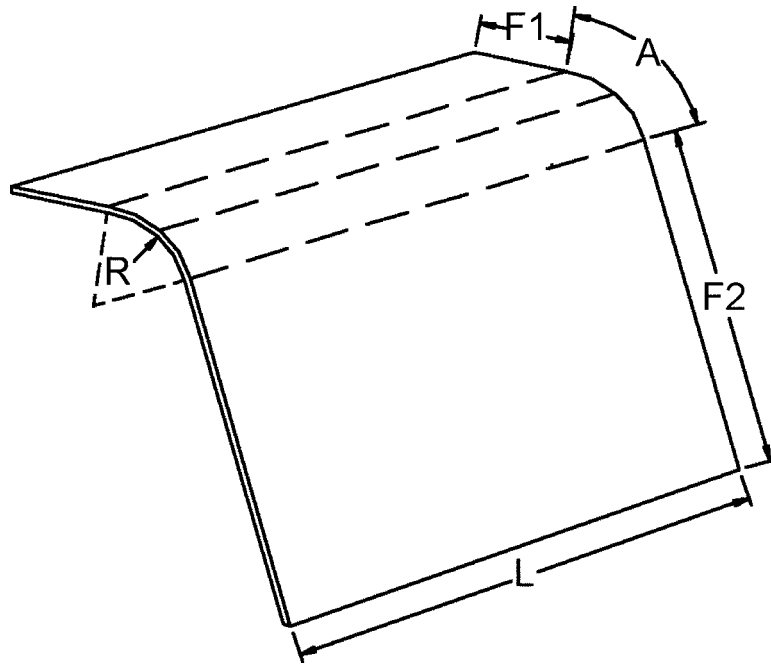

F1 = straight leg dimension
 F2 = straight leg dimension
 A = degree of angle
 R = radius of curve
 L = length

FIG. 2 Single Bend

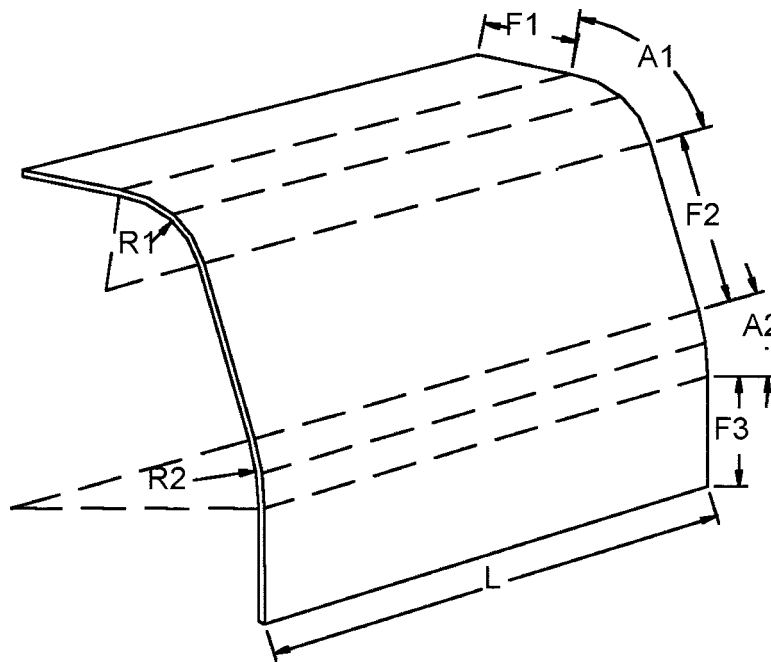

F1, F2, F3, = straight leg dimensions
 A1, A2 = curve angles
 R1, R2 = curve radii
 L = length

FIG. 3 Multiple Bend

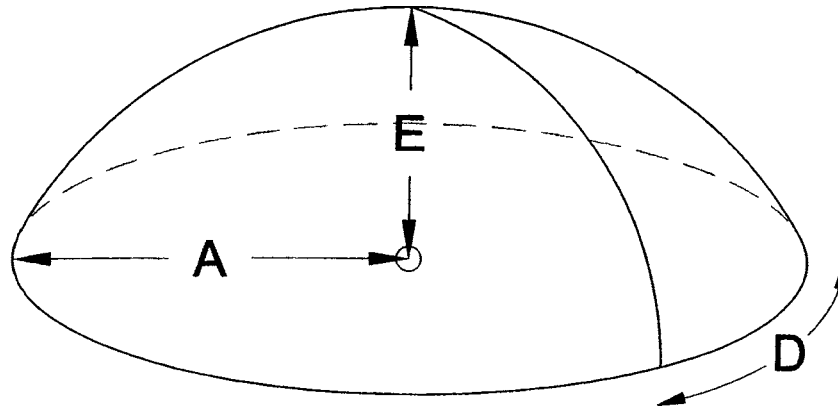

A = outside radius
 D = girth
 E = depth

FIG. 4 Compound Bend

6. Fabrication Requirements

6.1 Cutting to overall dimensions, edgework, drilled holes, notching, grinding, sandblasting, and etching are permissible.

6.1.1 When the glass is specified as chemically strengthened, heat-strengthened, or fully tempered, the fabrication processes in 6.1 must be completed prior to the strengthening process.

6.2 Glass intended for safety glazing applications as specified by building codes shall be permanently marked with the name or trademark of the manufacturer and the designation of the applicable safety glazing standard.

6.3 *Thickness Tolerances*—Thickness shall be in accordance with the thickness requirements of Specifications C 1036 and C 1172.

6.4 *Dimensional Tolerances:*

6.4.1 Height shall not exceed the deviations shown in Table 1.

6.4.2 Girth shall not exceed the deviations shown in Table 2.

6.4.3 Shape accuracy shall not exceed the deviations shown in Table 3.

6.4.4 Crossbend shall not exceed the deviations shown in Table 4.

6.4.5 Twist shall not exceed the deviations shown in Table 5.

6.5 *Blemishes*—For process surface blemishes, refer to Specifications C 1036 for flat glass and C 1172 for laminated glass.

TABLE 1 Height Tolerances

Height, mm (in.)	Nominal Glass Thickness, mm (in.)	
	Up to 12 (Up to 1/2)	>12 (>1/2)
0 to 1520 (0-60)	±3.2 (±1/8)	±4.8 (±3/16)
>1520 to 2000 (>60 to 78)	±3.2 (±1/8)	±4.8 (±3/16)
>2000 (>78)	±4.8 (±3/16)	±4.8 (±3/16)

TABLE 2 Girth Tolerances

Girth, mm (in.)	Nominal Glass Thickness, mm (in.)	
	Up to 12 (Up to 1/2)	>12 (>1/2)
0 to 1520 (0-60)	±3.2 (±1/8)	±4.8 (±3/16)
>1520 to 2500 (>60 to 78)	±4.8 (±3/16)	±6.4 (±1/4)
>2500 (>78)	±4.8 (±3/16)	±6.4 (±1/4)

TABLE 3 Shape Accuracy Tolerances

Girth, mm (in.)	Nominal Glass Thickness, mm (in.)			
	3-5 (1/8-3/16)	6-8 (1/4-5/16)	10-12 (3/8-1/2)	>12 (>1/2)
0-1220 (0-48)	±3.2 (±1/8)	±3.2 (±1/8)	±3.2 (±1/8)	±4.8 (±3/16)
>1220-2440 (>48-96)	±3.2 (±1/8)	±3.2 (±1/8)	±3.2 (±1/8)	±4.8 (±3/16)
>2440-3350 (>96-132)	±4.8 (±3/16)	±4.8 (±3/16)	±4.8 (±3/16)	±4.8 (±3/16)
>3350 (>132)	±4.8 (±3/16)	±4.8 (±3/16)	±4.8 (±3/16)	±6.4 (±1/4)

6.5.1 Pock marks shall not exceed 1.6 mm (1/16 in.) in the central portion of the glass and 2.4 mm (3/32 in.) in the outer area (see 7.3.4).

NOTE 1—The central area is considered to form an oval or circle centered on the lite whose axes or diameters do not exceed 80 % of the overall dimension. The remaining area is considered the outer area.

NOTE 2—Separated by at least 305 mm (12 in.).

6.5.2 Ring marks shall not exceed 1.6 mm (1/16 in.) in the central portion of the glass and 2.4 mm (3/32 in.) in the outer area (see 7.3.4). See Note 1 and Note 2.

7. Test Methods

7.1 *Impact Test for Safety Glazing*—Test and interpret in accordance with CPSC 16 CFR 1201.

TABLE 4 Maximum Crossbend Deviation, mm (in.)

Height, mm (in.)	Nominal Glass Thickness, mm (in.)			
	3-5 mm ($\frac{1}{8}$ - $\frac{3}{16}$)	6-8 mm ($\frac{1}{4}$ - $\frac{5}{16}$)	10-12 mm ($\frac{3}{8}$ - $\frac{1}{2}$)	>12 mm ($>\frac{1}{2}$)
0-1220 (0-48)	2.4 ($\frac{3}{32}$)	3.2 ($\frac{1}{8}$)	3.2 ($\frac{1}{8}$)	3.2 ($\frac{1}{8}$)
>1220-2440 (0.48-96)	3.2 ($\frac{1}{8}$)	3.2 ($\frac{1}{8}$)	4.8 ($\frac{3}{16}$)	4.8 ($\frac{3}{16}$)
>2440-3350 (>96-132)	4.8 ($\frac{3}{16}$)	4.8 ($\frac{3}{16}$)	4.8 ($\frac{3}{16}$)	4.8 ($\frac{3}{16}$)
>3350 (>132)	4.8 ($\frac{3}{16}$)	4.8 ($\frac{3}{16}$)	4.8 ($\frac{3}{16}$)	6.4 ($\frac{1}{4}$)

7.2 Dimensions:

7.2.1 Girth is measured on the convex surface with a flexible tape.

7.2.2 Length of edge is measured with a stable, sturdy tape.

7.3 Dimensional Inspection:

7.3.1 Shape accuracy is determined by placing a template on the concave surface of the bend, then measuring the deviation between the template and glass or placing glass arc on tracing of theoretical shape on either concave or convex line, then measuring the deviation between the tracing and the glass.

7.3.2 Twist is determined by setting glass in a 90° test fixture that is inclined 5 to 7° from vertical. The glass is positioned with the bottom corners in tight to the back surface. If required, the top corner that is touching, or closest to

touching, can be held against this surface. The actual distance that the other corner is away from the surface is the twist value.

7.3.3 Crossbend is determined by placing a straightedge along the vertical edge (perpendicular to the arc) on the concave surface of glass, then measuring the distance between the glass and straightedge.

7.3.4 *Visual Inspection*—Place specimen in a vertical position. The viewer shall look through the specimen, using daylight without direct sunlight, or using a background light suitable for observing the blemishes. View at 78 in. (2 m).

TABLE 5 Maximum Twist Deviation^A

Height, mm (in.)	Girth, mm (in.)				
	0-1830 (0-72)	>1830-2440 (>72-96)	>2440-3050 (>96-120)	>3050-3660 (>120-144)	>3660 (>144)
0-1830 (0-72)	3.2 ($\frac{1}{8}$)	3.2 ($\frac{1}{8}$)	4.8 ($\frac{3}{16}$)	4.8 ($\frac{3}{16}$)	6.4 ($\frac{1}{4}$)
>1830-2440 (72-96)	4.8 ($\frac{3}{16}$)	4.8 ($\frac{3}{16}$)	4.8 ($\frac{3}{16}$)	4.8 ($\frac{3}{16}$)	7.9 ($\frac{5}{16}$)
>2440-3050 (>96-120)	4.8 ($\frac{3}{16}$)	4.8 ($\frac{3}{16}$)	4.8 ($\frac{3}{16}$)	6.4 ($\frac{1}{4}$)	7.9 ($\frac{5}{16}$)
>3050 (>120)	4.8 ($\frac{3}{16}$)	4.8 ($\frac{3}{16}$)	6.4 ($\frac{1}{4}$)	6.4 ($\frac{1}{4}$)	9.5 ($\frac{3}{8}$)

^AThis table applies to 3-mm ($\frac{1}{8}$ -in.) glass to 12-mm ($\frac{1}{2}$ -in.) glass with a radius greater than 460 mm (18 in.). For twist tolerances on other thicknesses or radiuses, contact the supplier.

8. Keywords

8.1 bent glass; chemically strengthened; curved glass; heat-strengthened; laminated; tempered

ASTM International takes no position respecting the validity of any patent rights asserted in connection with any item mentioned in this standard. Users of this standard are expressly advised that determination of the validity of any such patent rights, and the risk of infringement of such rights, are entirely their own responsibility.

This standard is subject to revision at any time by the responsible technical committee and must be reviewed every five years and if not revised, either reapproved or withdrawn. Your comments are invited either for revision of this standard or for additional standards and should be addressed to ASTM International Headquarters. Your comments will receive careful consideration at a meeting of the responsible technical committee, which you may attend. If you feel that your comments have not received a fair hearing you should make your views known to the ASTM Committee on Standards, at the address shown below.

This standard is copyrighted by ASTM International, 100 Barr Harbor Drive, PO Box C700, West Conshohocken, PA 19428-2959, United States. Individual reprints (single or multiple copies) of this standard may be obtained by contacting ASTM at the above address or at 610-832-9585 (phone), 610-832-9555 (fax), or service@astm.org (e-mail); or through the ASTM website (www.astm.org).