



# Standard Practice for Installation of Precast Concrete Sewer, Storm Drain, and Culvert Pipe Using Standard Installations (Metric)<sup>1</sup>

This standard is issued under the fixed designation C 1479M; the number immediately following the designation indicates the year of original adoption or, in the case of revision, the year of last revision. A number in parentheses indicates the year of last reapproval. A superscript epsilon ( $\epsilon$ ) indicates an editorial change since the last revision or reapproval.

## 1. Scope

1.1 This practice covers the installation of precast concrete pipe intended to be used for the conveyance of sewage, industrial wastes, and storm water, and for the construction of culverts.

1.2 This specification is the metric counterpart of Specification C 1479.

1.3 *This standard does not purport to address all of the safety concerns, if any, associated with its use. It is the responsibility of the user of this standard to establish appropriate safety and health practices and determine the applicability of regulatory limitations prior to use.*

## 2. Referenced Documents

### 2.1 ASTM Standards:<sup>2</sup>

**C 822** Terminology Relating to Concrete Pipe and Related Products

**C 1417** Specification for Manufacture of Reinforced Concrete Sewer, Storm Drain, and Culvert Pipe for Direct Design

**D 698** Test Methods for Laboratory Compaction Characteristics of Soil Using Standard Effort (12 400 ft-lbf/ft<sup>3</sup> (600 kN-m/m<sup>3</sup>))

**D 1557** Test Methods for Laboratory Compaction Characteristics of Soil Using Modified Effort (56,000 ft-lbf/ft<sup>3</sup> (2,700 kN-m/m<sup>3</sup>))

**D 2487** Practice for Classification of Soils for Engineering Purposes (Unified Soil Classification System)

**D 2488** Practice for Description and Identification of Soils (Visual-Manual Procedure)

IEEE/ASTM SI 10 Standard for Use of the International System of Units (SI): The Modern Metric System

### 2.2 AASHTO Standards:<sup>3</sup>

Standard Specifications for Highway Bridges

**M 145** Classification of Soils and Soil—Aggregate Mixtures for Highway Construction Purposes

**T 99** The Moisture-Density Relations of Soils Using a 5.5-lb (2.5-kg) Rammer and a 12-in. (305-mm) Drop

**T 180** The Moisture-Density Relations of Soils Using a 10-lb (4.54-kg) Rammer and an 18-in. (457-mm) Drop

**T 310** In-Place Density and Moisture Content of Soil and Soil-Aggregate by Nuclear Methods (Shallow Depth)

### 2.3 ASCE Standard:<sup>4</sup>

**ASCE 15** Standard Practice for the Direct Design of Buried Precast Reinforced Concrete Pipe Using Standard Installations (SIDD)

## 3. Terminology

3.1 For definitions of terms relating to concrete pipe, see Terminology **C 822**.

3.2 For terminology related to soil classifications, see Practices **D 2487** and **D 2488**.

3.3 For terminology and definitions of terms relating to structural design, see **ASCE 15**.

3.4 **Fig. 1** illustrates the definitions and limits of the terms: foundation, subgrade, bedding, outer bedding, middle bedding, haunch, lower side, backfill or overfill, invert, crown, springline, top of pipe, and bottom of pipe as used in this practice.

## 4. Significance and Use

4.1 This practice is useful as a reference by an owner and the owner's engineer in preparing project specifications.

## 5. Notations

$D_i$  = inside diameter of pipe, mm

$D_o$  = outside diameter of pipe, mm

$H$  = design height of earth above top of pipe, m

$w$  = unit weight of soil, N/m<sup>3</sup>

<sup>1</sup> This practice is under the jurisdiction of ASTM Committee C13 on Concrete Pipe and is the direct responsibility of Subcommittee C13.05 on Special Projects.

Current edition approved Dec. 15, 2007. Published January 2008. Originally approved in 2007. Last previous edition approved in 2007 as C 1479M – 07.

<sup>2</sup> For referenced ASTM standards, visit the ASTM website, [www.astm.org](http://www.astm.org), or contact ASTM Customer Service at [service@astm.org](mailto:service@astm.org). For *Annual Book of ASTM Standards* volume information, refer to the standard's Document Summary page on the ASTM website.

<sup>3</sup> Available from American Association of State Highway and Transportation Officials (AASHTO), 444 N. Capitol St., NW, Suite 249, Washington, DC 20001, <http://www.transportation.org>.

<sup>4</sup> Available from American Society of Civil Engineers (ASCE), 1801 Alexander Bell Dr., Reston, VA 20191, <http://www.asce.org>.

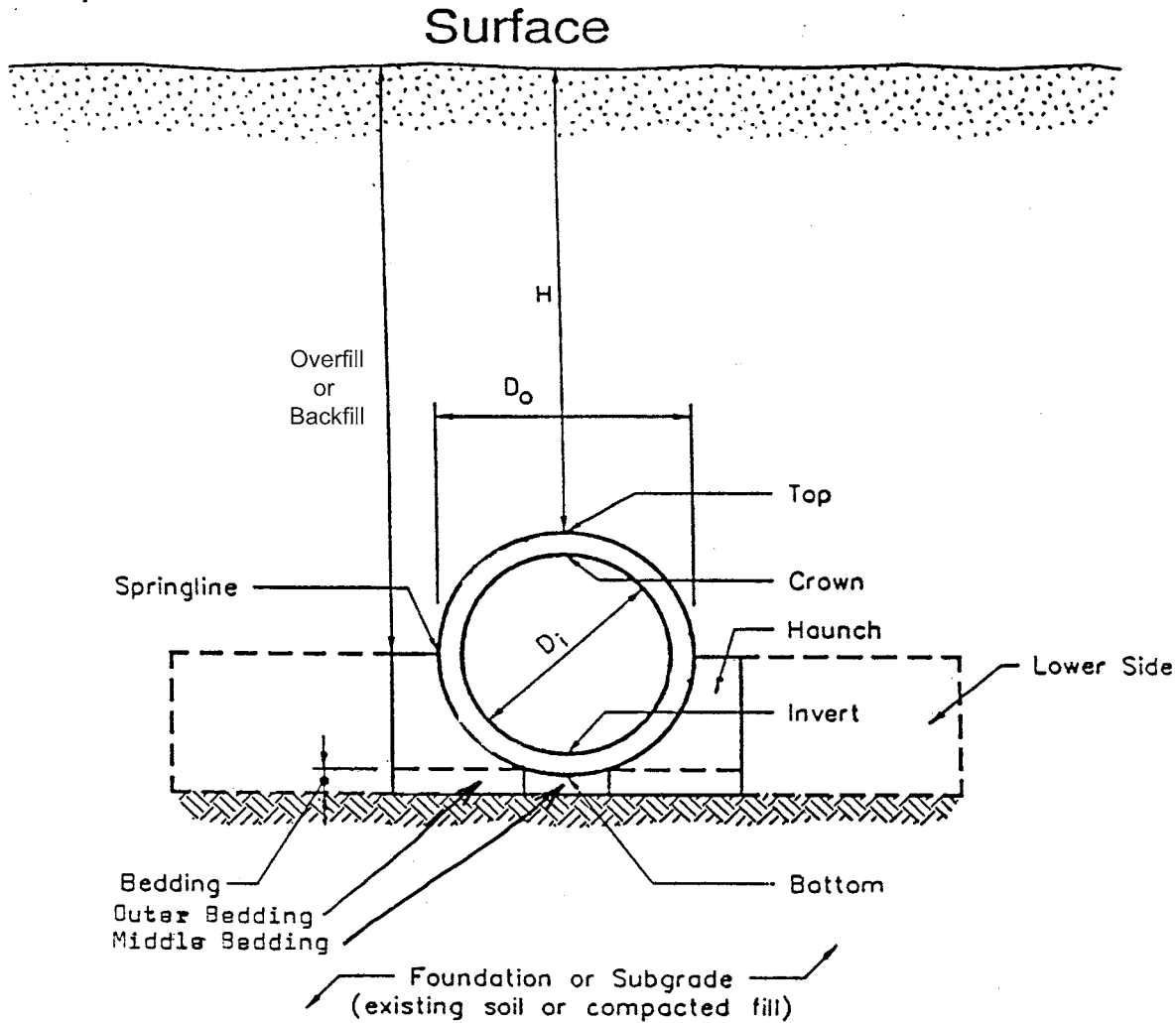

FIG. 1 Pipe/Installation Terminology

## 6. Standard Installations

6.1 The precast concrete pipe/soil system shall be constructed to conform to the requirements of Figs. 2 and 3 and Tables 1 and 2 as designated on the plans.

## 7. Excavation

7.1 When rock or other unyielding foundation material is encountered, it shall be removed at least to the requirements shown in Figs. 2 and 3 and Tables 1 and 2. Overexcavated areas shall be backfilled with approved materials and compacted to at least the standard proctor density specified for the bedding.

7.2 Where surface water or groundwater conditions exist, the site and trench shall be dewatered.

## 8. Foundation

8.1 The foundation shall be moderately firm to hard in situ soil, stabilized soil, or compacted fill material.

8.2 When unsuitable or unstable material is encountered, the foundation shall be stabilized.

8.3 Methods to prevent migration of soil fines shall be provided when groundwater or existing soil conditions are conducive to particle migration. Gravelly soils, with little or no fines, could migrate under certain conditions, causing lack of support.

8.4 Pipe installed over an unyielding foundation shall be cushioned so as to prevent blasting shock when future blasting is anticipated in the area.

## 9. Bedding

9.1 The bedding shall be constructed uniformly over the full length of the pipe barrel, as required for the designated standard installation, to distribute the load-bearing reaction uniformly on the pipe barrel over its full length, and to maintain the required pipe grade. See Fig. 4. If placed in layers, the thickness of the layers shall be as required to achieve the specified compaction and as required by the project specifications.

9.2 The bedding layers for standard installation Types 1, 2, and 3 shall be placed to be as uniform as possible, but shall be

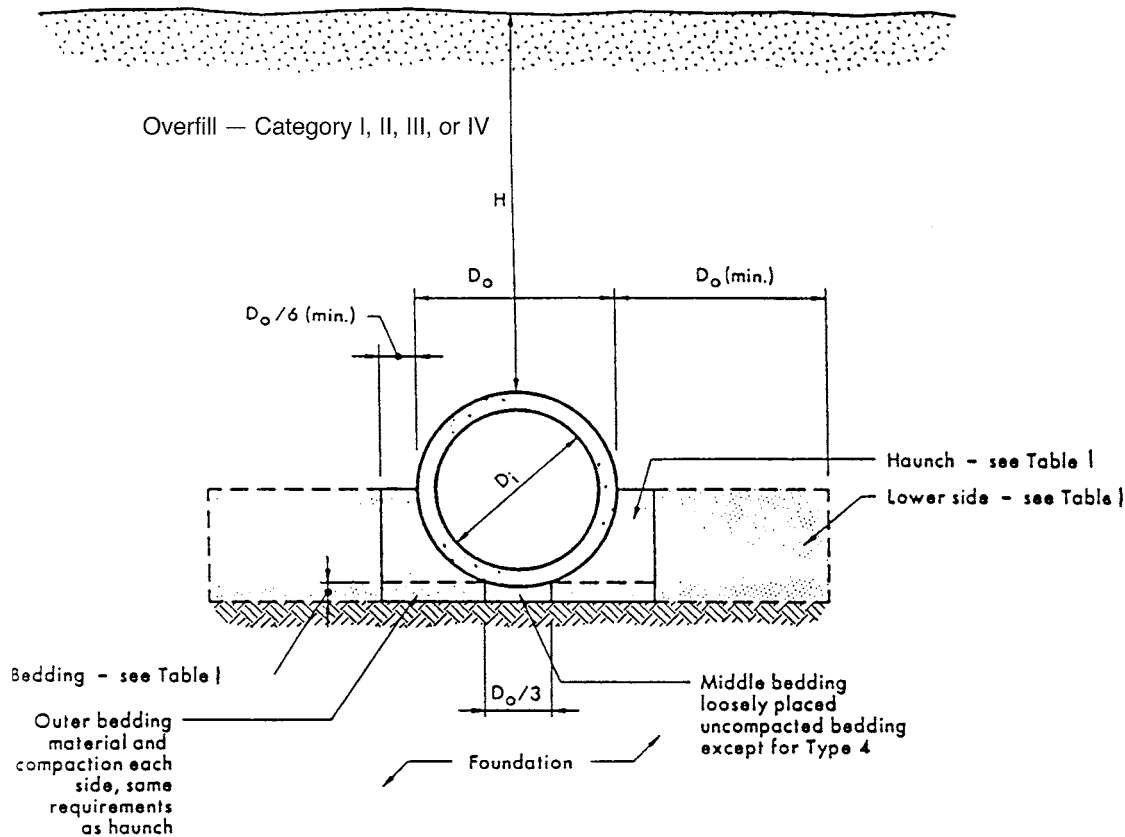

FIG. 2 Standard Embankment Installations

loosely placed uncompacted material under the middle third of the pipe prior to placement of the pipe.

9.3 The maximum aggregate size shall be 25 mm when the bedding thickness is less than 150 mm and 38 mm when the bedding thickness is 150 mm or greater, except as noted in 9.4.

9.4 When in situ soils conforming to project specifications are used in constructing the bedding for Type 3 and 4 installations, the maximum aggregate size shall not be greater than 75 mm, or half the bedding thickness, whichever is less.

9.5 The use of aggregate sizes larger than 25 mm shall be limited to 20 % of the bedding material by weight.

9.6 Bell holes shall be excavated in the bedding or foundation, or both, when installing pipe with expanded bells so that the pipe is supported by the barrel and not by the bells. See Fig. 4.

9.7 Any outer bedding under the lower side areas shall be compacted to at least the same requirements as for the lower side areas.

### 10. Pipe Placement and Joining

10.1 Pipe shall be installed to the line and grade shown on the project plans and specifications. The joint shall be as specified in the project specifications and shall be installed in accordance with the pipe manufacturer's recommendations.

NOTE 1—(Advisory) Where practical, work should be started at the lowest end of the pipeline and the pipe laid with the bell end up grade.

10.2 If required, the top of the pipe section being laid shall be positioned to the correct rotational orientation and then joined.

10.3 The bedding grade under the middle third of the pipe outside diameter shall be prepared before laying the pipe section. Making adjustments in grade by exerting force on the barrel of the pipe with excavating equipment, by lifting and dropping the pipe, or by lifting the pipe and packing bedding material under it shall be prohibited. If the installed pipe section is not on grade, the pipe section shall be completely unjoined, the grade corrected, and the pipe then rejoined.

### 11. Haunch

11.1 The haunch shall be constructed using the specified soil type and the minimum compaction level required for the designated standard installation. It shall be placed and compacted uniformly for the full length of the pipe barrel so as to distribute the load-bearing reaction uniformly to the bedding over the full length of the pipe barrel. If placed in layers, the thickness of the layers shall be as required to achieve the specified compaction and as required by the project specifications.

11.2 The maximum aggregate size for the haunch shall be the same as the maximum aggregate size in the bedding as defined in 9.3, except as noted in 11.3.

11.3 When in situ soils conforming to project specifications are used in constructing the pipe haunches for Type 3 and 4 installations, the maximum aggregate size shall not be greater than 75 mm.

11.4 The use of aggregate sizes larger than 25 mm shall be limited to 20 % of the haunch material by weight.

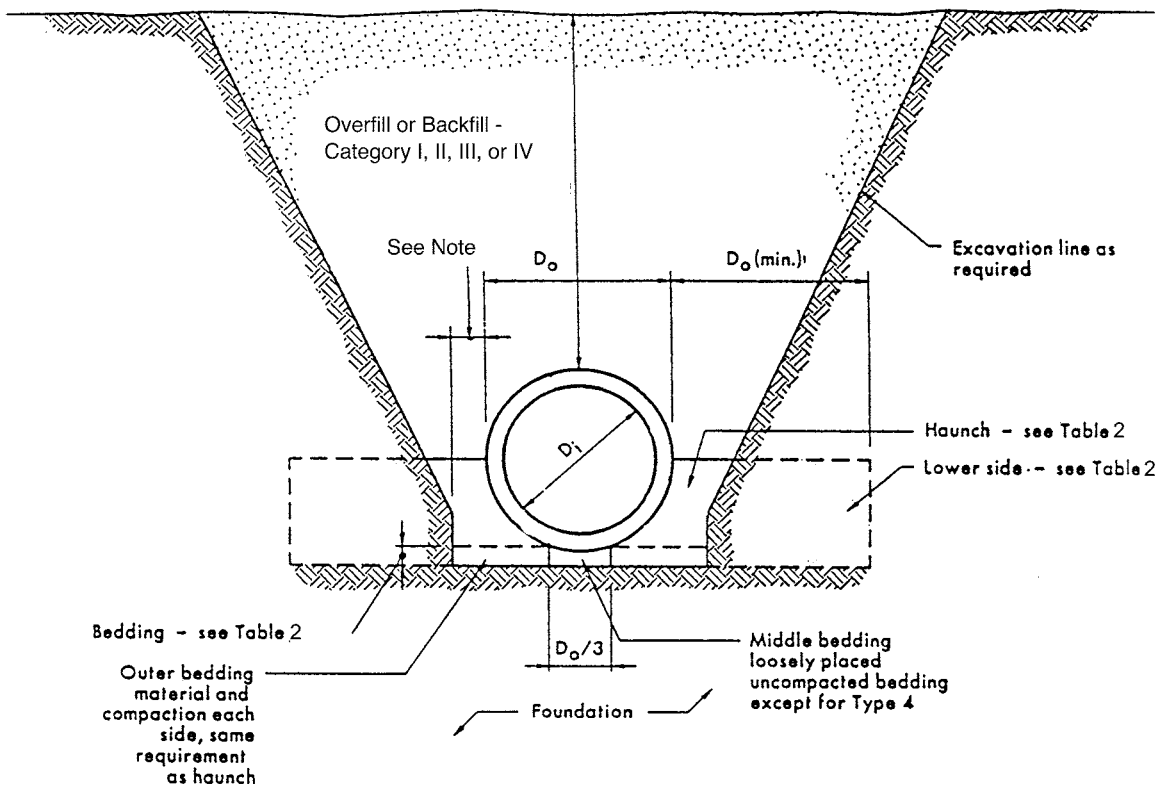

NOTE—Clearance between pipe and trench wall shall be adequate to enable specified compaction but not less than  $D_o/6$ .

FIG. 3 Standard Trench Installations

11.5 Placed soil shall be deposited and compacted to the specified density uniformly on each side of the pipe to prevent lateral displacement of the pipe.

## 12. Lower Side

12.1 The lower side, if not in situ, shall be constructed using the specified soil type and the minimum compaction level required for the designated standard installation. If placed in layers, the thickness of the layers shall be as required to achieve the specified compaction and as required by the project specifications.

12.2 The soil, if not in situ, shall be material conforming to the project specifications, and contain no debris, organic matter, frozen material, or large stones with a diameter greater than one half the thickness of the compacted layers being placed.

12.3 Placed soil shall be deposited and compacted to the specified density uniformly on each side of the pipe to prevent lateral displacement of the pipe.

## 13. Overfill

13.1 Overfill shall be constructed as specified in the project specifications. If placed in layers, the thickness of the layers

shall be as required to achieve the specified compaction and as required by the project specifications.

13.2 The soil shall be material conforming to the project specifications, and contain no debris, organic matter, frozen material, or large stones with a diameter greater than one half the thickness of the compacted layers being placed.

13.3 Placed soil shall be deposited and compacted to the specified density uniformly on each side of the pipe to prevent lateral displacement of the pipe. The overfill placed within one outside diameter of the pipe that is above the springline and below the top of the pipe shall be compacted to at least the same density as the majority of the overfill above the pipe.

13.4 When impact or vibratory equipment is used for compaction, care shall be taken to avoid damaging the pipe.

## 14. Sheathing Removal and Trench Shield Advancement

14.1 Unless sheathing is to be left in place, it shall be pulled out in vertical increments to permit placement and compaction of fill material for the full width of the trench.

14.2 When trench shields or boxes are moved, the previously placed pipe shall not be disturbed. The owner is advised that it may be necessary to restrain the installed pipe by use of

**TABLE 1 Standard Embankment Installation Soils and Minimum Compaction Requirements**

NOTE 1—Compaction and soil symbols (that is, 95 % Category I), refer to a soil material category with a minimum standard proctor density. See Table 3 for equivalent modified proctor values and soil types.

NOTE 2—Soil in the outer bedding, haunch, and lower side zones, except within  $D_o/3$  from the pipe springline, shall be compacted to at least the same compaction as the majority of soil in the overfill zone.

NOTE 3—Required bedding thickness is the thickness of the bedding prior to placement of the pipe.

NOTE 4—A subtrench is defined as a trench with its top below finished grade by more than 0.1H or, for roadways, its top is at an elevation lower than 0.3 m below the bottom of the pavement base material.

The minimum width of a subtrench shall be  $1.33 D_o$ , or wider, if required for adequate space to attain the specified compaction in the haunch and bedding zones.

For subtrenches, except within  $D_o/3$  from the springline, any portion of the lower side zone in the subtrench wall shall be at least as firm as an equivalent soil placed to the compaction requirements specified for the lower side zone and as firm as the majority of soil in the overfill zone, or it shall be removed and replaced with soil compacted to the specified level.

NOTE 5—“Dumped” material without additional compactive effort will not provide the design haunch support required for Type 1 and 2 installations and it should be checked for Type 3 installations.

Installation Type	Bedding Thickness	Haunch and Outer Bedding	Lower Side
Type 1	$D_o/24$ minimum; not less than 75 mm If rock foundation, use $D_o/12$ minimum; not less than 150 mm	95 % Category I	90 % Category I, 95 % Category II, or 100 % Category III
Type 2	$D_o/24$ minimum; not less than 75 mm If rock foundation, use $D_o/12$ minimum; not less than 150 mm	90 % Category I or 95 % Category II	85 % Category I, 90 % Category II, or 95 % Category III
Type 3	$D_o/24$ minimum; not less than 75 mm If rock foundation, use $D_o/12$ minimum; not less than 150 mm	85 % Category I, 90 % Category II, or 95 % Category III	85 % Category I, 90 % Category II, or 95 % Category III
Type 4	No bedding required, except if rock foundation, use $D_o/12$ minimum; not less than 150 mm	No compaction required, except if Category III, use 85 % Category III	No compaction required, except if Category III, use 85 % Category III

deadman anchors or other means. Voids that are created by movement of a shield or box shall be filled and compacted.

## 15. Precast Concrete Appurtenances

15.1 Manholes shall be installed in a manner that will minimize differential settlement between the pipe and manhole.

15.2 Precast concrete fittings, such as tees and wyes, shall be bedded, installed, and overfilled with the same material and in the same manner as the remainder of the pipeline to reduce the possibility of differential settlement between pipe and fittings.

## 16. Minimum Cover for Construction Loads

16.1 If the passage of construction equipment over an installed pipeline is necessary during project construction, compacted overfill in the form of a ramp shall be constructed to a minimum elevation of 0.9 m over the top of the pipe or to a height such that the equipment loads on the pipe do not exceed the pipe design strength. To prevent possible lateral

displacement of the pipe when the existing ground is higher or lower than the top of this ramp, the overfill shall extend a minimum of one pipe diameter width or 0.9 m, whichever is greater, beyond each side of the pipe and then have a gradual slope to ground level, not exceeding 1 vertical to 6 horizontal. If a large volume of construction traffic must cross an installed pipe, the point of crossing shall be changed occasionally to minimize the possibility of lateral displacement.

## 17. Safety

17.1 Safety requirements for construction shall be in accordance with the applicable federal, state, and local regulations.

17.2 Open ends of installed pipe shall be covered during overnight or longer periods of suspended work to prevent access by animals, personnel, and accumulation of soil and debris. Covers shall be braced or fastened to prevent movement. It is not required that these covers be watertight.

NOTE 2—(Advisory) If the pipe is plugged watertight when empty, the possibility of pipe flotation should be investigated, and, if necessary, appropriate measures shall be taken to prevent flotation.

**TABLE 2 Standard Trench Installation Soils and Minimum Compaction Requirements**

NOTE 1—Compaction and soil symbols (that is, 95 % Category I), refer to a soil material category with a minimum standard proctor density. See [Table 3](#) for equivalent modified proctor values and soil types.

NOTE 2—When the trench width specified must be exceeded, the owner shall be notified.

NOTE 3—The trench width shall be wider than shown ([Fig. 3](#)) if required for adequate space to attain the specified compaction in the haunch and bedding zones.

NOTE 4—Embankment loading shall be used when trench walls consist of embankment unless a geotechnical analysis is made and the soil in the trench walls is compacted to a higher level than the soil in the backfill zone.

NOTE 5—Required bedding thickness is the thickness of the bedding prior to placement of the pipe.

NOTE 6—“Dumped” material without additional compactive effort will not provide the design haunch support required for Type 1 and 2 installations and it should be checked for Type 3 installations.

Installation Type	Bedding Thickness	Haunch and Outer Bedding	Lower Side
Type 1	$D_o/24$ minimum; not less than 75 mm If rock foundation, use $D_o/12$ minimum; not less than 150 mm	95 % Category I	Undisturbed natural soil with firmness equivalent to the following placed soils: 90 % Category I, 95 % Category II, 100 % Category III, or embankment to the same requirements
Type 2	$D_o/24$ minimum; not less than 75 mm If rock foundation, use $D_o/12$ minimum; not less than 150 mm	90 % Category I or 95 % Category II	Undisturbed natural soil with firmness equivalent to the following placed soils: 85 % Category I, 90 % Category II, 95 % Category III, or embankment to the same requirements
Type 3	$D_o/24$ minimum; not less than 75 mm If rock foundation, use $D_o/12$ minimum; not less than 150 mm	85 % Category I, 90 % Category II, or 95 % Category III	Undisturbed natural soil with firmness equivalent to the following placed soils: 85 % Category I, 90 % Category II, 95 % Category III, or embankment to the same requirements
Type 4	No bedding required, except if rock foundation, use $D_o/12$ minimum; not less than 150 mm	No compaction required, except if Category III, use 85 % Category III	No compaction required, except if Category III, use 85 % Category III



**TABLE 3 Equivalent USCS and AASHTO Soil Classifications for Soil Designations**

Soil	Representative Soil Types		Percent Compaction	
	USCS ASTM Practice D 2487	AASHTO M 145	Standard Proctor	Modified Proctor
Category I	Clean, coarse grained soils: SW, SP, GW, GP or any soil beginning with one of these symbols with 12 % or less passing a 75 µm sieve	A-1, A-3	100 95 90 85	95 90 85 80
Category II	Coarse grained soils with fines: GM, GC, SM, SC or any soil beginning with one of these symbols, containing more than 12 % passing a 75 µm sieve  Sandy or gravelly fine-grained soils: CL, ML, (or CL-ML, CL/ML, ML/CL) with 30 % or more retained on a 75 µm sieve	A-2-4, A-2-5, A-2-6; or A-4 or A-6 soils with 30 % or more retained on a 75 µm sieve	100 95 90 85	95 90 85 80
Category III	Fine-grained soils: CL, ML, (or CL-ML, CL/ML, ML/CL) with less than 30 % retained on a 75 µm sieve	A-2-7; or A-4 or A-6 with less than 30 % retained on a 75 µm sieve	100 95 90 85	90 85 80 75
Category IV but not allowed for haunch or bedding	MH, CH, OL, OH, PT	A-5, A-7	100 95 90	90 85 80

Compaction Specifications:  
 Standard proctor density—AASHTO T 99, T 310, or Test Methods D 698  
 Modified proctor density—AASHTO T 180 or Test Methods D 1557

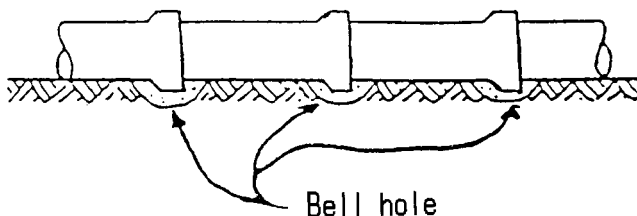

**FIG. 4 Uniform Pipe Support**

## APPENDIXES

### (Nonmandatory Information)

#### X1. COMMENTARY

X1.1 *Scope*—When buried, concrete pipe is part of a composite system comprised of the pipe and the surrounding soil envelope, which interact and contribute to the strength and structural behavior of the system. The SIDD method accounts for the interaction between the pipe and soil envelope in determining loads and distribution of earth pressure on a buried pipe.

X1.2 The standard installations as shown in Figs. 2 and 3 and Tables 1 and 2 are a part of this practice. They are based

on the results of research on pipe/soil interaction, together with evaluation of current construction practice, equipment, procedures, and experience.

X1.3 The design of a concrete pipe for a particular standard installation type is based on the assumption that the specified design bedding and fill requirements will be achieved during construction of the installation.

X1.4 See Specification C 1417 for the manufacture of reinforced concrete pipe for direct design.

## X2. STANDARD INSTALLATIONS

X2.1 The four types of standard embankment installations and four types of standard trench installations are shown in [Figs. 2 and 3](#). The standard installations are ranked according to the bedding and embedment soil materials, the required construction effort, and quality control. The Type I installation requires the most effort and control, while the Type 4 installation requires the least. Soil classifications are in accordance with Practice [D 2487](#) and Practice [D 2488](#).

X2.1.1 Type 1 is the highest quality standard installation. It generally has a flat bedding and requires Category I soil compacted to 95 % of standard proctor density to be placed in the haunch and underlying bedding zones and extend at least  $D_o/6$  beyond the outside of the pipe at its springline, up to at least the springline. The foundation must be in stable and longitudinally uniform in situ soil. A bedding layer of Category I granular soil with a minimum thickness of  $D_o/24$ , but not less than 75 mm, is required over the top of the foundation to avoid placing the pipe directly on a hard and possibly variable subgrade. This layer should be placed to be as uniform as possible, but it need not be compacted until after the pipe is set to grade. The portions of the bedding layer directly under the haunches should then be compacted to the same amount as will be provided in the haunch fill prior to placing and compacting the haunch fill. A bedding width of  $D_o/3$  centered on the invert should not be compacted, and it should be maintained in a uniformly loose state. Minimum bedding soil thickness should be increased to  $D_o/12$ , but not less than 150 mm, if rock is immediately below the pipe.

X2.1.2 Soil in the embankment adjacent to the haunches should be compacted to the minimum levels shown in [Tables 1 and 2](#) for lower side. If pipe is placed in a sub-trench within an embankment, the soil in the walls of this trench should have a firmness that is equivalent to the stiffness of the specified placed soils. Soil above the springline should not be compacted to a higher degree than soil in the lower sides. This may require an increase in the minimum compaction density of the lower side soils, if the compaction densities required for overfill are greater than those specified in [Tables 1 and 2](#) for lower side. This provision also may require removal of soft soil, soil with inadequate stiffness in the walls or foundation of a sub-trench, or sides of a sloped trench, for a minimum distance of one pipe diameter next to the pipe, as shown in [Figs. 2 and 3](#).

X2.1.3 Type 2 is the highest quality standard installation where certain native soils are permitted to be used with proper compaction in the haunch and bedding zones. Requirements are similar to Type 1, except that native Category II soils with a compaction of 95 % of standard proctor density, or Category

I soils with a 90 % compaction level may be used in the haunch and outer bedding zones. This is intended to allow the use of soil types frequently found at a site. The use of Category III and Category IV soils are not permitted in the haunch zones. The embankment adjacent to the pipe haunches should be compacted to the minimum densities given in [Tables 1 and 2](#) for lower side, except compaction in this region must not be less than overfill compaction. Any natural soils in the lower side should have a firmness equivalent to the placed soils specified in [Tables 1 and 2](#), as explained for Type 1.

X2.1.4 Type 3 permits the use of soils in the haunch and bedding zones having less stringent compaction requirements, justifying less stringent inspection requirements with granular soils and some native soils. Requirements are similar to Type 2, except that lower minimum levels of compaction are permitted for soils in the haunch zones (90 % for Category II, and 85 % for Category I). Category III soils may be used in the haunch zone if compacted to 95 % of standard proctor density. This will require a very large compactive effort, which must be controlled by testing. Other requirements are the same as those explained in [X2.1.1](#) and [X2.1.3](#) for Types 1 and 2.

X2.1.5 Type 4 is intended for installations where the most cost-effective design approach is to specify minimal requirements for embedment soil type and density, together with a pipe having sufficient strength to safely resist the increased structural effects that result from using low-quality embedment soils. Thus, Type 4 has no requirements for control of compaction and type of placed soil used in the bedding and haunch zones, except if Category III soils are used in the haunch zone or below this zone, they must be compacted to at least 85 % of standard proctor density, and Category IV soils should not be used in this zone. No bedding is required unless the foundation is rock. It is desirable, however, to scarify (loosen) hard native soils before placing the pipe. If the foundation immediately below the bedding is rock, the pipe should be placed on a bedding layer with a minimum thickness of  $D_o/12$ , but not less than 150 mm. Furthermore, soil in the embankment adjacent to the haunch zone must be compacted to at least the level of compaction of the majority of soil in the overfill zones above the springline, or have equivalent stiffness, if the zone contains natural soil in a sub-trench or sloping wall trench.

X2.2 The location of soil type and compaction requirements for the standard installations are presented in [Figs. 2 and 3](#) and [Tables 1 and 2](#). [Table 3](#) relates the standard installations designated soils to the AASHTO and Unified Soil Classification System (USCS) categories.



### X3. LOWER SIDE, INSPECTION, AND OVERFILL

X3.1 *Lower Side*—The stiffness of the soil in the lower side zone relative to the stiffness of the soil in the overfill is an important factor in determining the earth load on the pipe. The lower side acts like a shelf on which the earth load rests. This lowers the magnitude of the earth load that the pipe must resist. A stiff soil in the lower side resists more load than a soft soil. **Tables 1 and 2** show acceptable soils and compaction levels for the lower side.

X3.1.1 **Table 2** requires soils in the lower side zone to be embankment of certain compaction levels or undisturbed natural soil with firmness equivalent to certain embankment soils. This is because the stiffness of embankment soils has been defined and natural soil has not. Undisturbed natural soil of a given type and compaction level is stiffer than embankment of the same soil type and compaction level. For instance, undisturbed natural Category II soil with a compaction of 85 % is probably as stiff as 90 or 95 % Category II embankment. Most undisturbed natural soils are adequate for the lower side.

When the natural soil in the lower side zone included in the trench wall is soft, it may require a geotechnical engineer to determine the relative stiffness of the natural soil.

X3.1.2 Restrictions on subtrenches included in the notes listed in **Table 1** for embankment installations are needed to define the relationship between the stiffness of the lower side and the soil above the lower side or overfill.

X3.2 *Inspection*—The owner is advised to provide for or require adequate inspection of the pipe installation at the construction site.

X3.3 *Overfill*—In order to reduce the load on the pipe and to help prevent over compaction in this area, it is recommended that the soil immediately over the pipe not be compacted for a depth of about  $\frac{1}{3}$  the outside diameter of the pipe above the top of the pipe unless the project specifications require compaction in this area.

*ASTM International takes no position respecting the validity of any patent rights asserted in connection with any item mentioned in this standard. Users of this standard are expressly advised that determination of the validity of any such patent rights, and the risk of infringement of such rights, are entirely their own responsibility.*

*This standard is subject to revision at any time by the responsible technical committee and must be reviewed every five years and if not revised, either reapproved or withdrawn. Your comments are invited either for revision of this standard or for additional standards and should be addressed to ASTM International Headquarters. Your comments will receive careful consideration at a meeting of the responsible technical committee, which you may attend. If you feel that your comments have not received a fair hearing you should make your views known to the ASTM Committee on Standards, at the address shown below.*

*This standard is copyrighted by ASTM International, 100 Barr Harbor Drive, PO Box C700, West Conshohocken, PA 19428-2959, United States. Individual reprints (single or multiple copies) of this standard may be obtained by contacting ASTM at the above address or at 610-832-9585 (phone), 610-832-9555 (fax), or service@astm.org (e-mail); or through the ASTM website (www.astm.org).*