



# Standard Test Method for Determination of Pack-Set Index of Portland Cement<sup>1</sup>

This standard is issued under the fixed designation C 1565; the number immediately following the designation indicates the year of original adoption or, in the case of revision, the year of last revision. A number in parentheses indicates the year of last reapproval. A superscript epsilon ( $\epsilon$ ) indicates an editorial change since the last revision or reapproval.

## 1. Scope

1.1 This test method covers the determination of the pack-set index, which provides an indication of the mechanical force needed to overcome the consolidation of portland cement.

1.2 The pack-set index number provides a numerical value useful for manufacturers who desire to measure and control the effect that vibration-induced consolidation has upon the manufactured cement.

1.3 The values stated in SI units are to be regarded as the standard. Values stated in Inch-Pound units are for informational purposes only and are enclosed in parentheses. Values stated in SI units shall be obtained by measurement in SI units or by appropriate conversion, using the rules of Conversion and rounding given in Standard IEEE/ASTM SI 10, of measurements made in other units.

1.4 *This standard does not purport to address all of the safety concerns, if any, associated with its use. It is the responsibility of the user of this standard to establish appropriate safety and health practices and determine the applicability of regulatory limitations prior to use. (WARNING—Fresh hydraulic-cementitious mixtures are caustic and may cause chemical burns to skin and tissue upon prolonged exposure.)*<sup>2</sup>

## 2. Referenced Documents

### 2.1 ASTM Standards:<sup>3</sup>

C 1005 Specification for Reference Masses and Devices for Determining Mass and Volume for Use in the Physical Testing of Hydraulic Cements

IEEE/ASTM SI 10 International System of Units (SI) The Modernized Metric System

## 3. Terminology

### 3.1 Definitions of Terms Specific to This Standard:

<sup>1</sup> This test method is under the jurisdiction of ASTM Committee C01 on Cement and is the direct responsibility of Subcommittee C01.20 on Additions.

Current edition approved August 1, 2004. Published September 2004. Originally approved in 2003. Last previous edition approved in 2003 as C 1565 – 03.

<sup>2</sup> Section on Safety, Manual of Cement Testing, *Annual Book of ASTM Standards*, Vol 04.01.

<sup>3</sup> For referenced ASTM standards, visit the ASTM website, [www.astm.org](http://www.astm.org), or contact ASTM Customer Service at [service@astm.org](mailto:service@astm.org). For *Annual Book of ASTM Standards* volume information, refer to the standard's Document Summary page on the ASTM website.

3.1.1 *maximum voltage, n*—as pertaining to this method only, the energy in volts applied to consolidate the sample, which results in the maximum pack-set index for a particular cement and the apparatus used for the measurement.

3.1.2 *pack set, n*—a condition of hydraulic cement, exhibited in varying degrees, following silo storage or transport in bulk railcars or trucks, that causes the cement to resist flowing until considerable mechanical effort has been applied.

3.1.3 *pack-set index, n*—the numerical indication of the degree of pack set a particular cement exhibits when subjected to the procedures of this test method.

## 4. Summary of Test Method

4.1 Portland cement is placed into a flask and then consolidated on a vibrating table by a vibration force controlled by time and energy (volts). The consolidated bed is measured for relative strength by turning the flask to a horizontal position and rotating in 180° increments until the bed collapses from the bottom of the flask. The number of half turns is a relative indication of the force required to overcome the consolidation and is designated the pack-set index, or P.S.I.

## 5. Significance and Use

5.1 This method is intended to help manufacturers determine the relative pack-set tendency of their cement(s). The test establishes a pack-set index which, when properly correlated with field performance, is useful in predicting or preventing field unloading difficulties.

5.2 The test is an aid to routine control during cement production and is not suitable for specification purposes.

5.3 In general, field performance of cement flowability is satisfactory when the pack-set index as determined on freshly ground cement averages 0 to 15 and is unsatisfactory when the index exceeds 25. Any prediction of field performance of cement flowability measuring 16 to 25 is tenuous. These are general ranges and the field performance of individual cements may not necessarily fall within these ranges. Additional conditions, after the cement has left the control of the manufacturing facility, can affect the apparent pack set index as well.

5.4 Any attempt to apply the critical range of pack-set index numbers based on freshly ground cement to job cement without special treatment of the sample would be problematic. The test is a “GO-NO GO” type of test and should not be used for specification purposes.

5.5 The pack-set index of field cement can be evaluated in terms of the pack-set index ranges of that cement as determined when freshly-ground. This comparison can aid the manufacturer in producing cement that offers the best field performance for pack-set properties.

5.6 Silo storage of cement may result in a greater amount of consolidation than this method is designed to induce, and the resulting forces required to overcome that consolidation are not measured by this test method.

5.7 Pack set is not to be confused with “warehouse set” which results from surface hydration of the cement from adsorbed moisture.

## 6. Interferences

6.1 Results obtained from the pack-set test are dependent on sample exposure (See Note 1).

NOTE 1—Fresh cement has a greater pack-set tendency. Cement stored in silos for only a day or two will test similar to fresh cement. Cement stored in full silos, where aeration is negligible, may develop lower pack-set indices upon further aging. Even samples in sealed containers may vary.

6.2 Pack-set index determination can be affected by sample temperature (See Note 2).

NOTE 2—Cement with a temperature noticeably hotter than room temperature may produce a different pack-set index number than that same cement cooled to room temperature. Cooling of hot cement samples must be accomplished with minimum aeration to avoid moisture and CO<sub>2</sub> adsorption.

6.3 The testing room humidity can significantly influence the determined pack-set index.

6.4 Keep the apparatus level during the testing procedure.

6.5 The vibration energy transferred to the sample is affected by the support given the apparatus (See Note 3). The determination of pack-set index for unknown samples shall be accomplished on the same physical support that the maximum voltage for the test was determined on.

NOTE 3—Apparatus which is not setting firmly on the counter or table may not deliver repeatable results.

6.6 Vibration energy delivered by the table is related to the proper handling and adjustment of the table. See Section 7 for details.

6.7 Vibration energy delivered by the table is related to the frequency of the source voltage. This variation, if present, will result in a poor repeatability and require more frequent determination of the maximum voltage.

## 7. Apparatus

7.1 *Erlenmeyer Flask*, 250 mL capacity, regular wall thickness, fitted with a number 14 (large diameter 32 mm and small diameter 25 mm) cork stopper. Flasks are not interchangeable. Each flask and cork combination must have the maximum voltage determined prior to use in the test method (See Note 4).

7.2 *Reference Masses and Devices for Determining Mass* shall conform to the requirements of Specification C 1005 as appropriate for the size of the sample, the mass of which is to be determined, with a sensitivity of no less than 0.1 g and a readability of 0.1 g or less.

NOTE 4—There are enough differences between Erlenmeyer flasks of the same rated capacity to cause significant difference in the pack-set index. It is recommended that several flasks which deliver similar pack-set index numbers for the same cement be kept as spares.

7.3 *Vibrating Table*, (see Fig. 1), capable of generating electromagnetic vibrations at the frequency of 60 Hz, having a wooden top with dowel pins installed equidistant from each other on the circumference of the circle centered on the table, with a radius slightly greater than the largest radius of the flask (to restrain the flask movement on the table).<sup>4</sup> A device that is capable of stopping any lateral movement of the flask during vibration is required (See Note 5). The air gap setting between the armatures of the vibrating table is critical to the generation of the proper vibrational amplitude and must be adjusted according to the manufacturer’s instructions. Manufacturer’s recommendations and precautions for proper operation must be followed to assure the accurate determination of the pack set index.

NOTE 5—Three or four dowel pins of 6 to 10 mm diameter and 25 to 30 mm long will be sufficient to restrain the flask. Interconnecting rubber bands or rubber cam-locks can be used to restrain the flask to prevent lateral movement of the flask during vibration.

7.4 *Roto-Tester*, (see Fig. 2), a device on which the Erlenmeyer flask can be mounted in a horizontal position against a vertical, flat, rotating plate that contains frictional hold-down cams to prevent the flask from falling, and capable of smoothly rotating the flask and table while in that horizontal position, in 180° increments at the rate of approximately 40 one-half rotations per minute with a short partial second pause between half-rotations. The device shall be equipped with a counter capable of recording the number of one-half rotations of the table.<sup>5</sup>

7.5 *Voltmeter*, capable of measuring and displaying the voltage delivered to the vibrating table to the nearest 0.5 VAC.

7.6 *Variable-voltage Transformer*, inductance-type, capable of supplying the vibrating table with voltage within the range of 0 v to 100 % of the design voltage of the vibrating table.

7.7 *Automatic Timer*, capable of controlling the “ON” time of the variable-voltage transformer and the vibrating table to 15 ± ½ s.

## 8. Preparation of Apparatus—Determination of Maximum Voltage

8.1 Determine the maximum voltage applied to the vibrating table to achieve the maximum pack-set index number for a sample.

8.1.1 Turn the vibrating table ON, and using the voltage adjustment of the variable-transformer, set the voltage so that little or no compaction takes place in the cement sample during the 15 s vibration. Increment the voltage by 2v until the

<sup>4</sup> The sole source of supply of the apparatus known to the committee at this time is the FMC Syntron Model J-1 Vibrating Table, manufactured by the FMC Technologies Company, Homer City, PA. 15748. If you are aware of alternative suppliers, please provide this information to ASTM International Headquarters. Your comments will receive careful consideration at a meeting of the responsible technical committee<sup>1</sup>, which you may attend.

<sup>5</sup> The Roto-tester is a specialized apparatus with limited commercial availability. A list of possible suppliers can be obtained from ASTM if needed.

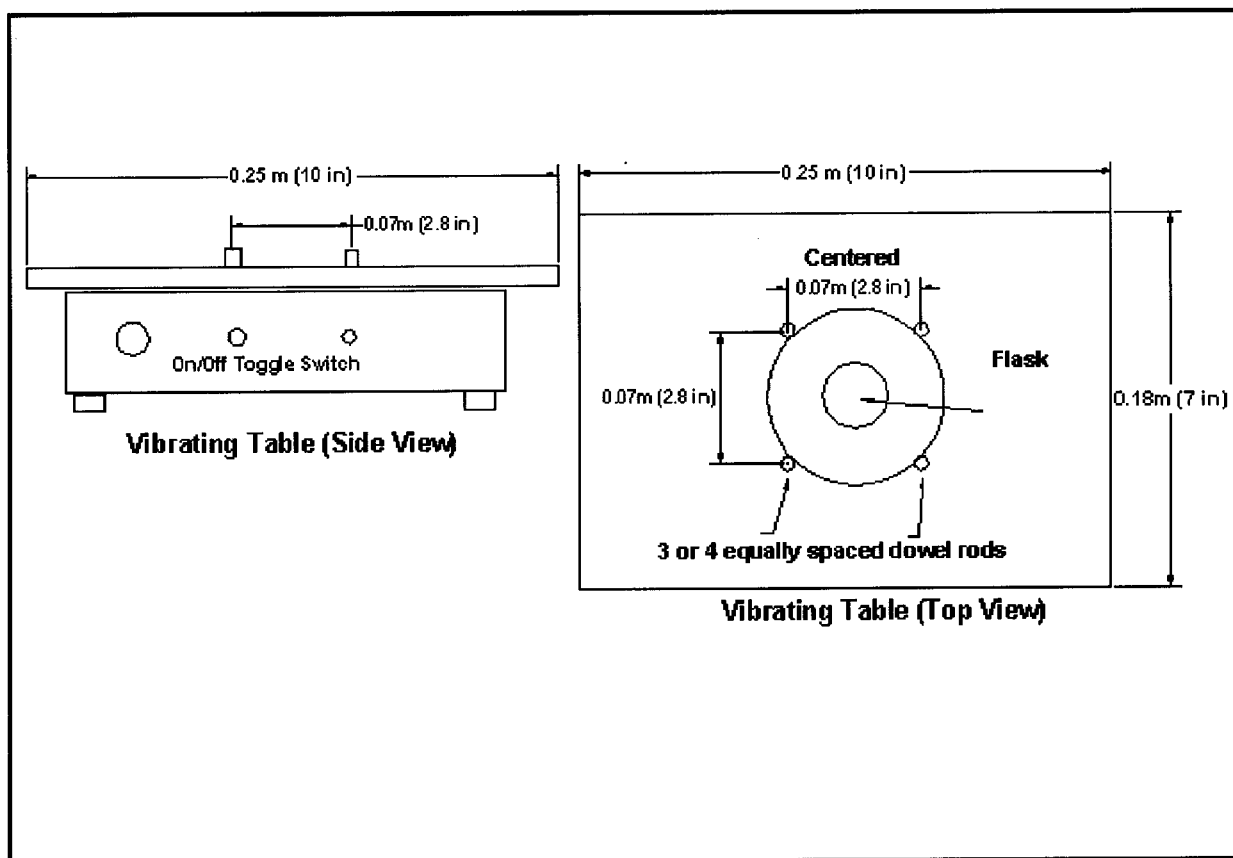

FIG. 1 Vibrating Table

compaction achieved result is a pack-set index value greater than zero. Continue incrementing the voltage by 2v until a pack-set index is determined that is lower than the index determined using the preceding voltage. The preceding voltage is the maximum voltage for that cement and apparatus combination (See Note 6).

NOTE 6—The test method uses the concept of vibration voltage increasing in order to develop cement bed compaction from nearly nothing to that voltage which provides a maximum pack-set index, to that voltage which disrupts the compaction and reduces the pack-set index to below the maximum. A starting voltage somewhere between 40-60 volts will generally satisfy that need.

8.2 Determine the maximum voltage for the following conditions:

- 8.2.1 For each type of cement from a single source.
- 8.2.2 For samples obtained in the field or for interlaboratory testing.
- 8.2.3 Whenever the flask or cork is changed.
- 8.2.4 Whenever the vibrating table, voltmeter, variable-transformer, timer, or Roto-Tester are adjusted or replaced.
- 8.2.5 No less frequently than every 1 month for any single cement from a single source.

**9. Conditioning**

9.1 Maintain the temperature of the room and dry materials at  $23.0 \pm 3.0$  °C.

9.2 Maintain the relative humidity of the testing room at a minimum of 50 %.

9.3 Sieve all samples through an 850- $\mu$ m (No. 20) mesh screen prior to the pack-set determination.

9.4 Prior to each use, clean the inside and outside of the flask, the table top of the vibrating table, and the roto-tester with a dry clean cloth.

**10. Procedure**

10.1 Place  $100.0 \pm 0.1$  g of cement, or  $90.0 \pm 0.1$  g if Type III cement, into the clean flask. Stopper tightly with the cork stopper to avoid spillage.

10.2 *De-agglomeration:*

10.2.1 Support the flask with the neck maintained in a nearly horizontal position (consider nearly horizontal to be less than 90° but more than 70° from the vertical position of the flask). Rotate the flask one-half turn in the same direction. Continue rotation at the rate of two half-turns per second for a minimum of 10 s (See Note 7).

10.2.2 Level the bed of cement by manually suspending the flask by the neck in an upright position and gently swirling the flask about its longitudinal axis. Avoid excessive shaking or swirling which can cause re-agglomeration of the cement particles.

NOTE 7—Proper and sufficient de-agglomeration is required for acceptable repeatability of the test. Operators should practice the procedure to

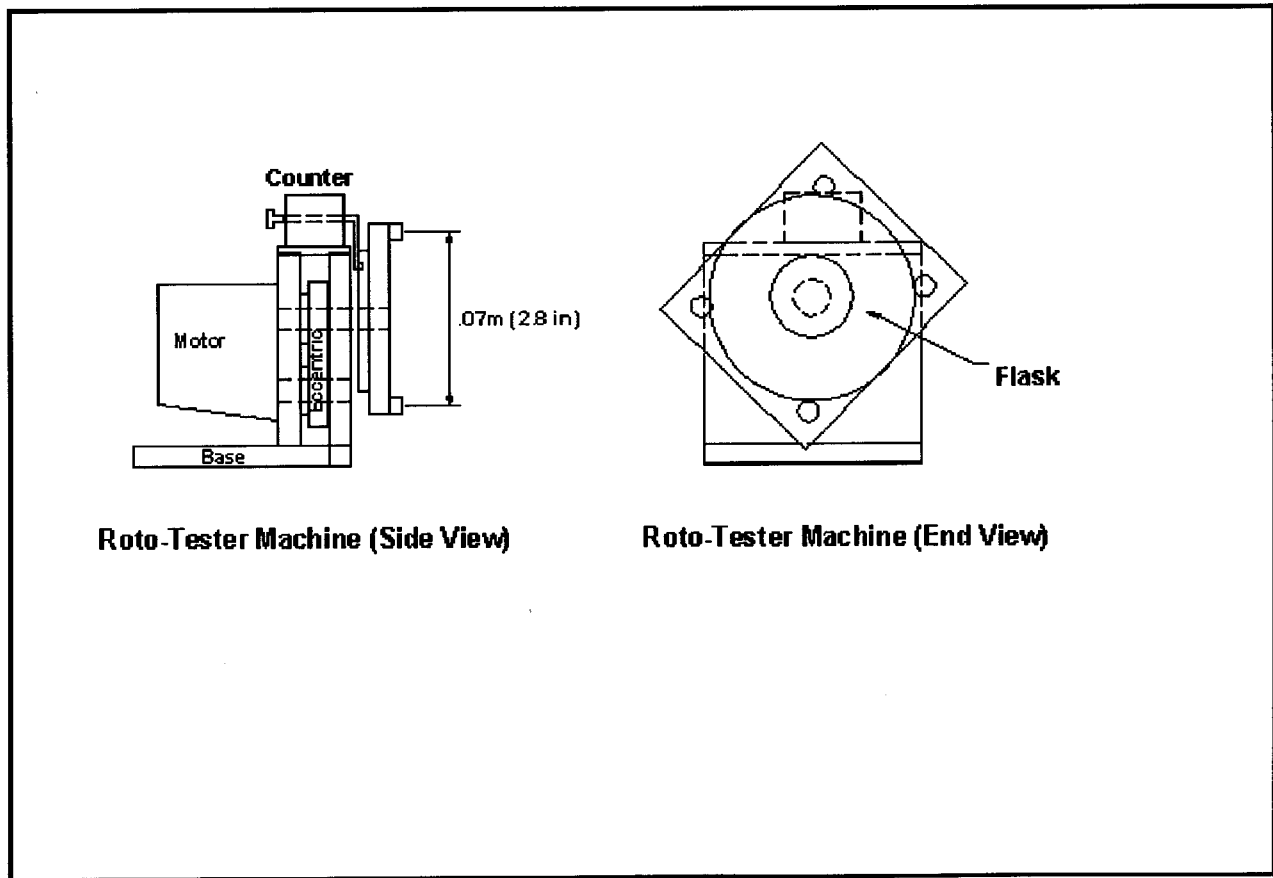

FIG. 2 Roto-Tester

reduce differences between repeat determinations of the index.

10.3 Insure that the voltage supplied to the vibrating table is set at the predetermined maximum voltage. The table must be “ON” for this procedure. Turn the table “OFF” when finished.

10.4 Gently place the flask onto the vibrating table inside of the retaining dowels, engage the restraining device in such a manner as to insure zero lateral movement between dowels and flask wall during vibration. Set the timer for 15 s, and operate the vibrating table for the 15 s.

10.5 Remove the flask from the table, gently tip the flask to a horizontal position, place the flask into the roto-tester, carefully fasten the flask into the roto-tester with the friction cam clamps. The bottom of the flask and the roto-tester table must be contacting each other over the entire circumference of the flask. Read the counter on the roto-tester or reset the counter to zero. Operate the roto-tester until the consolidated bed of cement collapses from the bottom of the flask. Turn the roto-tester “off” and read the counter. If the bed only partially collapses, consider the run invalid if the bed does not completely collapse within two additional one-half rotations. Subtract the beginning number from the ending number to determine the number of one-half rotations required to collapse the bed of cement (See Note 8).

10.6 Make five (5) determinations using steps 10.2, 10.4, and 10.5.

NOTE 8—Under some circumstances, the number of half-turns for a single run will go above 50. When the number of turns does go above 50, it is permissible to stop the roto-tester and record the result as “50+.”

## 11. Calculation of Results

11.1 Calculate the pack-set index by averaging the results of the five runs. Round the average to the nearest whole number.

## 12. Report

12.1 Report the pack-set index as a whole number, abbreviated, if desired, as P.S.I. and the maximum voltage used to obtain the result. For example, “P.S.I. = 10 at 56 v.”

## 13. Precision and Bias

13.1 Test data for the determination of pack-set index precision is being evaluated by Subcommittee C01.20. Statements of precision will be included in a later revision of this test method.

13.2 Since there is no accepted reference material suitable for determining any bias that may be associated with this test method, no statement is being made.

## 14. Keywords

14.1 maximum voltage; pack set; pack-set index; portland cement; roto-tester

*ASTM International takes no position respecting the validity of any patent rights asserted in connection with any item mentioned in this standard. Users of this standard are expressly advised that determination of the validity of any such patent rights, and the risk of infringement of such rights, are entirely their own responsibility.*

*This standard is subject to revision at any time by the responsible technical committee and must be reviewed every five years and if not revised, either reapproved or withdrawn. Your comments are invited either for revision of this standard or for additional standards and should be addressed to ASTM International Headquarters. Your comments will receive careful consideration at a meeting of the responsible technical committee, which you may attend. If you feel that your comments have not received a fair hearing you should make your views known to the ASTM Committee on Standards, at the address shown below.*

*This standard is copyrighted by ASTM International, 100 Barr Harbor Drive, PO Box C700, West Conshohocken, PA 19428-2959, United States. Individual reprints (single or multiple copies) of this standard may be obtained by contacting ASTM at the above address or at 610-832-9585 (phone), 610-832-9555 (fax), or [service@astm.org](mailto:service@astm.org) (e-mail); or through the ASTM website ([www.astm.org](http://www.astm.org)).*