



Standard Practice for Sampling of Gaseous Uranium Hexafluoride¹

This standard is issued under the fixed designation C 1703; the number immediately following the designation indicates the year of original adoption or, in the case of revision, the year of last revision. A number in parentheses indicates the year of last reapproval. A superscript epsilon (ϵ) indicates an editorial change since the last revision or reapproval.

1. Scope

1.1 This practice covers methods for withdrawing representative sample(s) of uranium hexafluoride (UF_6) during a transfer occurring in the gas phase. Such transfer in the gas phase can take place from a mother cylinder, for example in an autoclave to a receiving cylinder. It can also occur during the filling in the gas phase of a cylinder during a continuous production process, for example centrifuge enrichment facility or the distillation column in a conversion facility. Such sample(s) may be used for determining compliance with the applicable commercial specification, for example Specification C 996 or Specification C 787.

1.2 Since UF_6 sampling is taken during the filling process, this practice does not address any special additional arrangements that may be agreed upon between the buyer and the seller when the sampled bulk material is being added to residues already present in a container (“heels recycle”). Such arrangements will be based on QA procedures such as traceability of cylinder origin (to prevent for example contamination with irradiated material).

1.3 If the receiving cylinder is purged after filling and sampling, special verifications must be performed by the user to verify the representativity of the sample(s). It is then expected that the results found on volatile impurities with gas phase sampling may be conservative.

1.4 This practice is only applicable when the transfer occurs in the gas phase. When the transfer is performed in the liquid phase, Practice C 1052 should apply. This practice does not apply to gas sampling after the cylinder has been filled since the sample taken will not be representative of the cylinder.

1.5 The scope of this practice does not include provisions for preventing criticality incidents.

1.6 *This standard does not purport to address all of the safety concerns, if any, associated with its use. It is the responsibility of the user of this standard to establish appropriate safety and health practices and determine the applicability of regulatory limitations prior to use.*

¹ This practice is under the jurisdiction of ASTM Committee C26 on Nuclear Fuel Cycle and is the direct responsibility of Subcommittee C26.02 on Fuel and Fertile Material Specifications.

Current edition approved Dec. 1, 2008. Published December 2008.

2. Referenced Documents

2.1 ASTM Standards:²

C 761 Test Methods for Chemical, Mass Spectrometric, Spectrochemical, Nuclear, and Radiochemical Analysis of Uranium Hexafluoride

C 787 Specification for Uranium Hexafluoride for Enrichment

C 996 Specification for Uranium Hexafluoride Enriched to Less Than 5 % ²³⁵U

C 1052 Practice for Bulk Sampling of Liquid Uranium Hexafluoride

2.2 Other Document:

ISO/DIS 7195 Packaging of Uranium Hexafluoride (UF_6) for Transport³

3. Terminology

3.1 Definitions of Terms Specific to This Standard:

3.1.1 *container*—a vessel either holding or receiving by transfer, the UF_6 to be sampled; it may consist of, for example, a fixed vessel in a UF_6 handling plant or a cylinder to be used for the transport of UF_6 .

3.1.2 *sample vessel*—the small vessel into which the sample of UF_6 is withdrawn for analysis in the laboratory for characterization. It can be a 1S or 2S bottle or a PCTFE (polydifluorodichloroethylene)/ PTFE (polytetrafluoroethylene) pot or tube or any other type of cylinder compatible with UF_6 .

4. Summary of Practices

4.1 Two methods of withdrawing gas UF_6 for sampling are possible, namely: (1) continuous withdrawal using for example a capillary and producing only one sample, or (2) sequential withdrawals producing a composite sample. Depending on the pressure and temperature conditions during the transfer, the sampled UF_6 is either liquefied or solidified in the sample vessel.

² For referenced ASTM standards, visit the ASTM website, www.astm.org, or contact ASTM Customer Service at service@astm.org. For *Annual Book of ASTM Standards* volume information, refer to the standard's Document Summary page on the ASTM website.

³ Available from American National Standards Institute (ANSI), 25 W. 43rd St., 4th Floor, New York, NY 10036, <http://www.ansi.org>.

4.2 An example of (1) is the sampling of UF_6 coming from a distillation column. In such case, the sampled gas UF_6 can be condensed in the liquid phase in the sampling vessel. The representative sample is then homogenized before analysis at the laboratory. It is assumed that the flow rate from the distillation is either constant (for example using a mass flow controller) or that the capillary will take its variation in account.

4.3 Examples of (2) are the sampling of UF_6 from an autoclave or from the cascades of an enrichment facility. This would apply only to a stable process. In such case, the sequential withdrawals must take into account the potential variation of flow rate which must be continuously monitored during the transfer. A composite sample is prepared and is compared to an average calculation using on line analysis.

4.4 For both methods of sampling, the presence of residues may have significant implications for the quality of the UF_6 . For safety and quality reasons, cylinders and bottles shall be clean, dry, and empty before filling.

5. Significance and Use

5.1 Uranium hexafluoride is normally produced and handled in large (typically 1 to 14-ton) quantities and must, therefore, be characterized by reference to representative samples (see [ISO/DIS 7195](#)). The samples are used to determine compliance with the applicable commercial specifications [C 996](#) and [C 787](#). The quantities involved, physical properties, chemical reactivity, and hazardous nature of UF_6 are such that for representative sampling, specially designed equipment must be used and operated in accordance with the most carefully controlled and stringent procedures. This practice can be used by UF_6 converters, enrichers, and fuel fabricators to review the effectiveness of existing procedures or as a guide to the design of equipment and procedures for future use.

5.2 The intention of this practice is to avoid liquid UF_6 sampling once the cylinder has been filled. For safety reasons, manipulation of large quantities of liquid UF_6 should be avoided when possible.

5.3 It is emphasized that this practice is not meant to address conventional or nuclear criticality safety issues.

6. Hazards

6.1 Because of its chemical, radiochemical, and toxic properties, UF_6 is a hazardous material.

7. Principles

7.1 The essential purpose of the sample(s) is to be representative of the total material which has been transferred. It is the responsibility of the user to determine the way of continuous sampling or the number of samples and time distribution that are necessary to be representative, depending on the process variability. For example, in case of the presence of high level of very volatile impurities, additional samples may have to be taken at the beginning of the transfer.

7.1.1 It is recommended to validate the gas sampling using a comparison on several cylinders with liquid sampling after filling. Statistically significant sampling basis and requirement should be established. Adequacy shall be demonstrated by quality assurance procedures.

7.1.2 In case of the presence of volatile impurities close to the specification (for example within 80 % of the specification), a confirmation using liquid sampling may be necessary.

7.2 Uranium hexafluoride is very reactive and corrosive. It reacts readily with water, atmospheric moisture, certain metals, and many organic materials. For reasons of safety and to avoid contamination, precautions must be taken to avoid contact with such materials. The sampling equipment is therefore fabricated to appropriate high standards of vacuum and high temperature integrity, and components in direct contact with UF_6 are made from nickel, high-nickel alloys, or materials having equivalent resistance to UF_6 corrosion. The formation of an inert fluoride layer is often an important feature of UF_6 corrosion resistance, and hence, internal surfaces are generally conditioned with a suitable fluorinating agent, sometimes UF_6 itself.

7.3 Cross-contamination may occur between subsequent samples taken using the same equipment, and appropriate precautions must be taken to prevent this. It is therefore recommended that, before taking definitive samples, the equipment is flushed through with an aliquot of the material to be sampled. This is normally accomplished by taking an initial volume which is then rejected and not used for definitive analysis. Alternative procedures to prevent cross-contamination are possible and should be validated individually.

8. Procedure for Continuous Sampling During Filling of a Transport Cylinder

8.1 Sample Preparation:

8.1.1 The equipment consists of a continuous sampling vessel that has the ability to collect a desired weight/volume of UF_6 during the filling of a UF_6 transport cylinder, and a sample manifold used for obtaining the aliquot of UF_6 from the continuous sampling vessel. The sampling manifold can be a permanent (fixed) manifold, and can be the same manifold used for sampling straight from a product cylinder. The continuous sampling vessel should be fed gaseous UF_6 from a slip stream at the exit of the supplying source (for example, a distillation column) that is supplying UF_6 to a transport cylinder.

8.1.2 The continuous sampling vessel should be maintained at a temperature and pressure adequate for condensing and maintaining UF_6 in liquid phase, to allow for homogenization by the action of convection currents within the bulk liquid. The continuous sampling vessel should be operated so that a composite sample of UF_6 could be withdrawn during the entire filling cycle of a transport cylinder. The continuous sampling vessel should be able to be isolated from the supply so that adequate purging of the vessel and supply lines can be accomplished after the sampling cycle is complete.

8.1.3 The continuous sampling vessel should be opened to draw a sample from the UF_6 feed line at the beginning of filling of the transport cylinder. At the completion of filling of the transport cylinder the continuous sampler should be isolated from the feed line.

8.1.4 The sampling manifold should be appropriately sized to contain the quantity of UF_6 required for a single sample and normally, consists of the manifold and associated pipe work or may also include an additional metering volume (pipette). The

total graduated volume of the connected equipment (excluding the vacuum system) should not exceed the designated maximum fill volume of the attached sample vessels. Certain valves may be remotely operated as necessary. The sampling equipment should be heated to prevent the solidification of UF₆.

8.1.5 The weight/volume of UF₆ collected in the continuous sampling vessel should be monitored by load cell, so to not overflow the continuous sampling vessel. This sample volume should be adequate for flushing the piping between the continuous sampling vessel and the sampling manifold, as well as the manifold itself. The total volume of the sample manifold should be transferred to the sample cylinder without any venting.

8.2 *Sampling:*

8.2.1 The UF₆ can now be sampled into a desired number of sample vessels from the continuous sampling vessel.

8.2.2 Attach the sample vessel to the sampling manifold (if a fixed manifold is used) or attach the sampling equipment, including sample vessels, at the relevant location on the UF₆ runoff line from the continuous sampler. Evacuate and test the equipment to ensure vacuum integrity. Isolate the sample vessels from the sample manifold.

8.2.3 Open the valves on the continuous sampling vessel to allow liquid UF₆ to flow to the sampling manifold.

8.2.4 Establish liquid transfer of UF₆ from the UF₆ continuous sampling vessel to the sampling manifold. Allow a suitable amount of UF₆ to flush the sampling manifold and piping from the continuous sampler to manifold.

8.2.5 At an appropriate time, open the valve and withdraw the required quantity of UF₆ into the graduated volume. This may be indicated by the use of suitable temperature sensors, pressure transducers, strain gauges, a line of sight window at the top of the transfer pipette, or combinations thereof.

8.2.6 Close the manifold valve and open the first sample vessel valve to transfer the sample. The equipment should be designed to allow transfers to take place using the influence of

gravity and differential pressures induced by temperature gradients. For this reason, it may be necessary to cool the receiving vessels.

8.2.7 The first sample may be used to condition internal surfaces of the equipment by suitable manipulation of the vacuum system or rejected to prevent cross-contamination from earlier materials or both.

8.2.8 Isolate the sample vessel from the sampling manifold.

8.2.9 If successive samples are to be taken, repeat 8.2.5 and 8.2.6.

8.2.10 At the completion of sampling, close all the sample vessel valves. Any residual UF₆ in the equipment, sampling lines, and continuous sampling vessel is withdrawn using dry gas or evacuated into a UF₆ trap. Purge all equipment with dry gas several times to assure any residual vapors have been removed.

8.2.11 Remove, identify, cap, and weigh the sample vessels. Local safety regulations may demand that the UF₆ be allowed to cool and solidify before this operation is carried out.

9. Procedure for Sequential Sampling

9.1 *Description of the Main Steps:*

9.1.1 During cylinder filling, successive gas samples are isolated in an intermediate dosing vessel. The UF₆ is each time collected in the same vessel (CDG or 1S or alternative) which is maintained at low temperature. The frequency of withdrawal is regular. The number of transfers and the vessel volume are defined to ensure sufficient material for analyzing and providing a representative sample. A representative sample is ensured by withdrawing a quantity which is proportional to the flow rate, an appropriate frequency of withdrawing is used, the pressure is also checked and a cross check with on line analysis is carried out.

9.1.2 An on-line ²³⁵U isotopic analysis is performed at the same time; the UF₆ flow rate and the pressure in the vessel are constantly monitored. Ti and Qi are the ²³⁵U content and flow rate found at time i.

9.1.3 The ²³⁵U is measured on the UF₆ collected in the vessel and then compared to the average calculation using on-line measurement: $\sum Ti Qi / \sum Qi$.

9.1.4 If the difference between the two ²³⁵U values is not significant (based for example on a 95 % confidence limit), the stability of the process is considered sufficient and the material can be used for further sub-sampling and analysis according to Test Methods C 761 in order to verify the conformity to Specification C 996. If the difference is significantly different or if the pressure variability is too high, the gas phase sampling is not applicable and a new UF₆ sampling must be performed according to Practice C 1052 (with UF₆ liquefaction in the cylinder).

NOTE 1—In order to conform to Specification C 996, representativity of the sample regarding volatile impurities (B, Si) should be established (see 7.1.1). Alternatively, an on-line analysis of such impurities can be performed.

9.1.5 If the variation of Ti during the filling is too high (value to be agreed between buyer and seller), the cylinder may have to be homogenized before shipping to the customer.

9.2 *Description of the Equipment:*

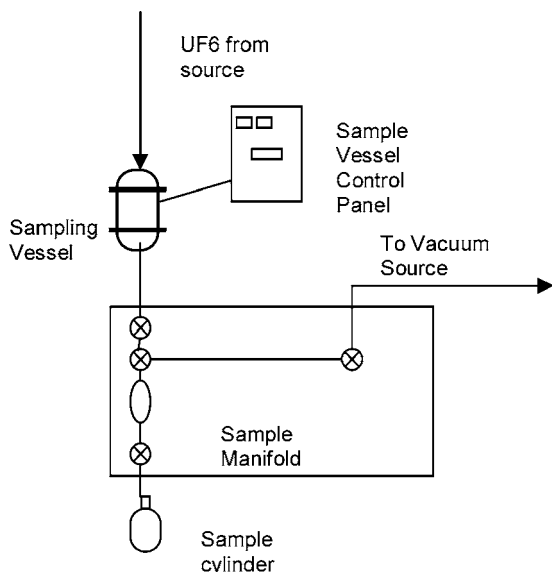

FIG. 1 Schematic Arrangement for Sampling According to Practice 1

9.2.1 The equipment consists of a dosing vessel which is connected to one or several sample vessels (see Fig. 2). This vessel is located as a bypass on the main UF_6 flow. The flowing gas in this vessel is isolated by closing valves V1 and V2 and is periodically transferred in the sample vessels using cryogenic transfer. The vessel, valves and instrumentation are located within a heated enclosure to prevent solidification of the UF_6 . The bottom of the sample vessels are kept cold to allow a cryogenic transfer. Due to the gaseous state of the UF_6 , homogeneity of the sampling is ensured.

9.3 *Procedure for Sampling Gaseous Uranium Hexafluoride:*

9.3.1 Create a vacuum in the sample manifold (vessel dispenser and sample vessels).

9.3.2 Check the equipment to ensure vacuum integrity.

9.3.3 Isolate the sample vessels from the sample manifold.

9.3.4 Establish gaseous transfer of UF_6 from the main flow to the sampling equipment.

9.3.5 Measure pressure, temperature, flow rate, isotope level of ^{235}U .

9.3.6 At an appropriate time, isolate the vessel dispenser and carry out cryogenic transfer from the bulk material into the vessels.

9.3.7 Renew the operations from 9.3.3 to 9.3.6 to do a composite sample.

9.3.8 When the withdrawal is finished isolate the sample vessel from the sampling manifold (close the sampling valves).

9.3.9 Remove the vessel with the composite sample.

9.3.10 Cap, weigh and identify the sample vessels.

10. Keywords

10.1 bulk sampling; nuclear material; uranium hexafluoride

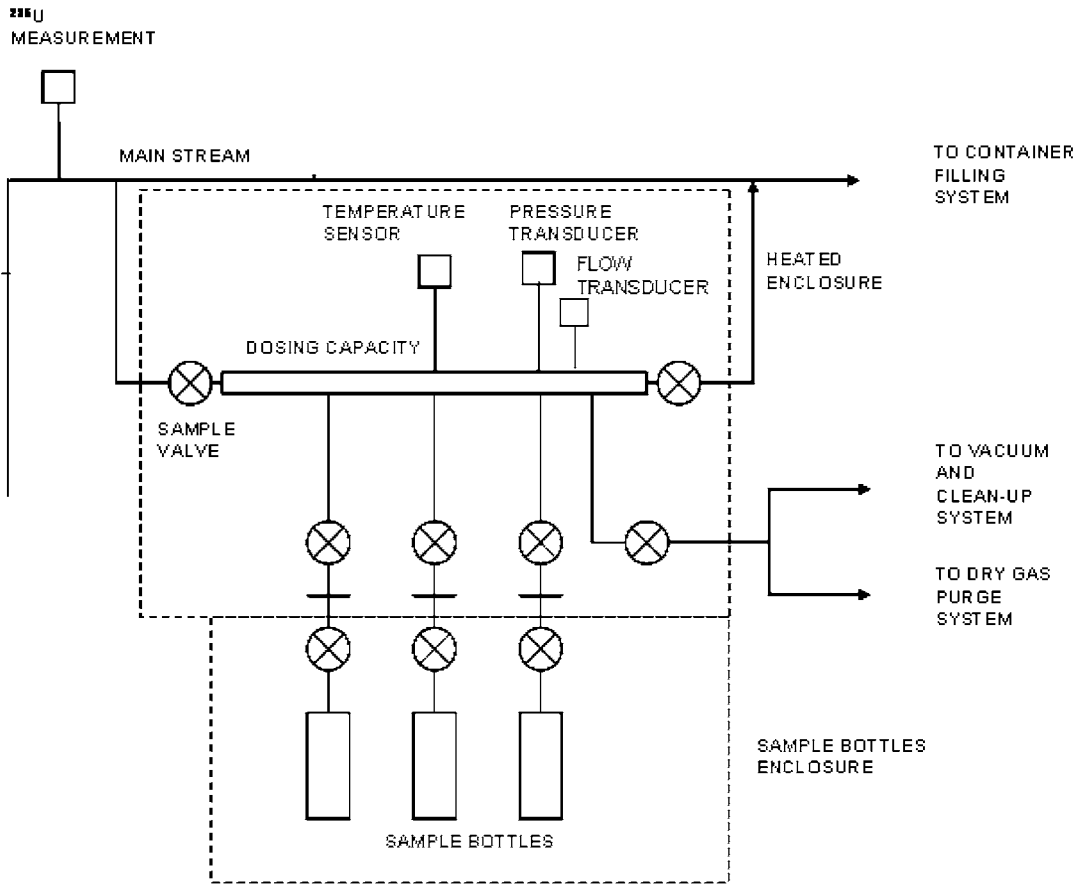

FIG. 2 Schematic Arrangement for Sampling According to Practice 2

ASTM International takes no position respecting the validity of any patent rights asserted in connection with any item mentioned in this standard. Users of this standard are expressly advised that determination of the validity of any such patent rights, and the risk of infringement of such rights, are entirely their own responsibility.

This standard is subject to revision at any time by the responsible technical committee and must be reviewed every five years and if not revised, either reapproved or withdrawn. Your comments are invited either for revision of this standard or for additional standards and should be addressed to ASTM International Headquarters. Your comments will receive careful consideration at a meeting of the responsible technical committee, which you may attend. If you feel that your comments have not received a fair hearing you should make your views known to the ASTM Committee on Standards, at the address shown below.

This standard is copyrighted by ASTM International, 100 Barr Harbor Drive, PO Box C700, West Conshohocken, PA 19428-2959, United States. Individual reprints (single or multiple copies) of this standard may be obtained by contacting ASTM at the above address or at 610-832-9585 (phone), 610-832-9555 (fax), or service@astm.org (e-mail); or through the ASTM website (www.astm.org).