



# Standard Test Methods for Fineness of Hydraulic Cement by Air-Permeability Apparatus<sup>1</sup>

This standard is issued under the fixed designation C 204; the number immediately following the designation indicates the year of original adoption or, in the case of revision, the year of last revision. A number in parentheses indicates the year of last reapproval. A superscript epsilon ( $\epsilon$ ) indicates an editorial change since the last revision or reapproval.

## 1. Scope\*

1.1 This test method covers determination of the fineness of hydraulic cement, using the Blaine air-permeability apparatus, in terms of the specific surface expressed as total surface area in square centimetres per gram, or square metres per kilogram, of cement. Two test methods are given: Test Method A is the Reference Test Method using the manually operated standard Blaine apparatus, while Test Method B permits the use of automated apparatus that has in accordance with the qualification requirements of this test method demonstrated acceptable performance. Although the test method may be, and has been, used for the determination of the measures of fineness of various other materials, it should be understood that, in general, relative rather than absolute fineness values are obtained.

1.1.1 This test method is known to work well for portland cements. However, the user should exercise judgement in determining its suitability with regard to fineness measurements of cements with densities, or porosities that differ from those assigned to Standard Reference Material No. 114.

1.2 The values stated in SI units are to be regarded as the standard.

1.3 *This standard does not purport to address all of the safety concerns, if any, associated with its use. It is the responsibility of the user of this standard to establish appropriate safety and health practices and determine the applicability of regulatory limitations prior to use.*

## 2. Referenced Documents

### 2.1 ASTM Standards:<sup>2</sup>

**A 582/A 582M** Specification for Free-Machining Stainless Steel Bars

**C 670** Practice for Preparing Precision and Bias Statements for Test Methods for Construction Materials

**E 832** Specification for Laboratory Filter Papers

### 2.2 Other Document:

**No. 114** National Institute of Standards and Technology Standard Reference Material<sup>3</sup>

**BS 4359: 1971** British Standard Method for the Determination of Specific Surface of Powders: Part 2: Air Permeability Methods<sup>4</sup>

## TEST METHOD A: REFERENCE METHOD

## 3. Apparatus

3.1 *Nature of Apparatus*—The Blaine air-permeability apparatus consists essentially of a means of drawing a definite quantity of air through a prepared bed of cement of definite porosity. The number and size of the pores in a prepared bed of definite porosity is a function of the size of the particles and determines the rate of airflow through the bed. The apparatus, illustrated in Fig. 1, shall consist specifically of the parts described in 3.2-3.8.

3.2 *Permeability Cell*—The permeability cell shall consist of a rigid cylinder  $12.70 \pm 0.10$  mm in inside diameter, constructed of austenitic stainless steel. The interior of the cell shall have a finish of  $0.81 \mu\text{m}$  ( $32 \mu\text{in.}$ ). The top of the cell shall be at right angles to the principal axis of the cell. The lower portion of the cell must be able to form an airtight fit with the upper end of the manometer, so that there is no air leakage between the contacting surfaces. A ledge  $\frac{1}{2}$  to 1 mm in width shall be an integral part of the cell or be firmly fixed in the cell  $55 \pm 10$  mm from the top of the cell for support of the perforated metal disk. The top of the permeability cell shall be fitted with a protruding collar to facilitate the removal of the cell from the manometer.

NOTE 1—Specification **A 582/A 582M** Type 303 stainless steel (UNS designation S30300) has been found to be suitable for the construction of the permeability cell and the plunger.

3.3 *Disk*—The disk shall be constructed of noncorroding metal and shall be  $0.9 \pm 0.1$  mm in thickness, perforated with 30 to 40 holes 1 mm in diameter equally distributed over its area. The disk shall fit the inside of the cell snugly. The center

<sup>1</sup> This test method is under the jurisdiction of ASTM Committee C01 on Cement and is the direct responsibility of Subcommittee C01.25 on Fineness.

Current edition approved Aug. 1, 2007. Published September 2007. Originally approved in 1946. Last previous edition approved in 2005 as C 204 – 05.

<sup>2</sup> For referenced ASTM standards, visit the ASTM website, [www.astm.org](http://www.astm.org), or contact ASTM Customer Service at [service@astm.org](mailto:service@astm.org). For *Annual Book of ASTM Standards* volume information, refer to the standard's Document Summary page on the ASTM website.

<sup>3</sup> Available from National Institute of Standards and Technology (NIST), 100 Bureau Dr., Stop 1070, Gaithersburg, MD 20899-1070, <http://www.nist.gov>.

<sup>4</sup> Available from British Standards Institute (BSI), 389 Chiswick High Rd., London W4 4AL, U.K., <http://www.bsi-global.com>.

\*A Summary of Changes section appears at the end of this standard.

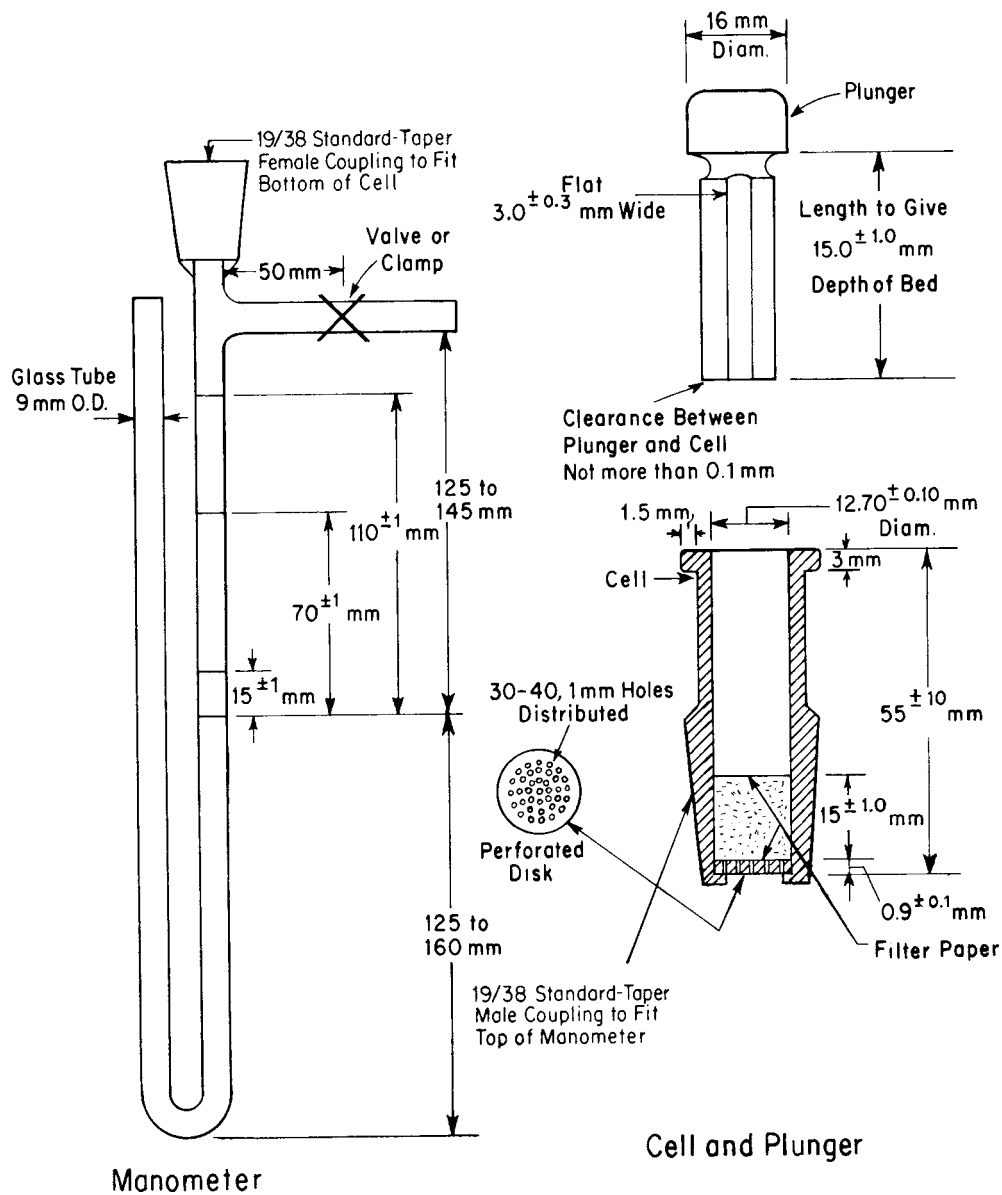

FIG. 1 Blaine Air-Permeability Apparatus

portion of one side of the disk shall be marked or inscribed in a legible manner so as to permit the operator always to place that side downwards when inserting it into the cell. The marking or inscription shall not extend into any of the holes, nor touch their peripheries, nor extend into that area of the disk that rests on the cell ledge.

3.4 *Plunger*—The plunger shall be constructed of austenitic stainless steel and shall fit into the cell with a clearance of not more than 0.1 mm. The bottom of the plunger shall sharply meet the lateral surfaces and shall be at right angles to the principal axis. An air vent shall be provided by means of a flat  $3.0 \pm 0.3$  mm wide on one side of the plunger. The top of the plunger shall be provided with a collar such that when the plunger is placed in the cell and the collar brought in contact with the top of the cell, the distance between the bottom of the plunger and the top of the perforated disk shall be  $15 \pm 1$  mm.

3.5 *Filter Paper*—The filter paper shall be medium retentive, corresponding to Type 1, Grade B, in accordance with

Specification E 832. The filter paper disks shall be circular, with smooth edges, and shall have the same diameter (Note 2) as the inside of the cell.

NOTE 2—Filter paper disks that are too small may leave part of the sample adhering to the inner wall of the cell above the top disk. When too large in diameter, the disks have a tendency to buckle and cause erratic results.

3.6 *Manometer*—The U-tube manometer shall be constructed according to the design indicated in Fig. 1, using nominal 9-mm outside diameter, standard-wall, glass tubing. The top of one arm of the manometer shall form an airtight connection with the permeability cell. The manometer arm connected to the permeability cell shall have a midpoint line etched around the tube at 125 to 145 mm below the top side outlet and also others at distances of  $15 \pm 1$  mm,  $70 \pm 1$  mm, and  $110 \pm 1$  mm above that line. A side outlet shall be provided at 250 to 305 mm above the bottom of the manometer for use

in the evacuation of the manometer arm connected to the permeability cell. A positive airtight valve or clamp shall be provided on the side outlet not more than 50 mm from the manometer arm. The manometer shall be mounted firmly and in such a manner that the arms are vertical.

**3.7 Manometer Liquid**—The manometer shall be filled to the midpoint line with a nonvolatile, nonhygroscopic liquid of low viscosity and density, such as dibutyl phthalate (dibutyl 1,2-benzene-dicarboxylate) or a light grade of mineral oil. The fluid shall be free of debris.

**3.8 Timer**—The timer shall have a positive starting and stopping mechanism and shall be capable of being read to the nearest 0.5 s or less. The timer shall be accurate to 0.5 s or less for time intervals up to 60 s, and to 1 % or less for time intervals of 60 to 300 s.

#### 4. Calibration of Apparatus

**4.1 Sample**—The calibration of the air permeability apparatus shall be made using the current lot of NIST Standard Reference Material **No. 114**. The sample shall be at room temperature when tested.

**4.2 Bulk Volume of Compacted Bed of Powder**—Determine the bulk volume of the compacted bed of powder by the mercury displacement method as follows:

**4.2.1** Place two filter paper disks in the permeability cell, pressing down the edges, using a rod having a diameter slightly smaller than that of the cell, until the filter disks are flat on the perforated metal disk; then fill the cell with mercury, ACS reagent grade or better, removing any air bubbles adhering to the wall of the cell. Use tongs when handling the cell. If the cell is made of material that will amalgamate with mercury, the interior of the cell shall be protected by a very thin film of oil just prior to adding the mercury. Level the mercury with the top of the cell by lightly pressing a small glass plate against the mercury surface until the glass is flush to the surface of the mercury and rim of the cell, being sure that no bubble or void exists between the mercury surface and the glass plate. Remove the mercury from the cell and measure and record the mass of the mercury. Remove one of the filter disks from the cell. Using a trial quantity of 2.80 g of cement (**Note 3**) compress the cement (**Note 4**) in accordance with **4.5** with one filter disk above and one below the sample. Into the unfilled space at the top of the cell, add mercury, remove entrapped air, and level off the top as before. Remove the mercury from the cell and measure and record the mass of the mercury.

**4.2.2** Calculate the bulk volume occupied by the cement to the nearest 0.005 cm<sup>3</sup> as follows:

$$V = (W_A - W_B)/D \quad (1)$$

where:

- $V$  = bulk volume of cement, cm<sup>3</sup>,
- $W_A$  = grams of mercury required to fill the cell, no cement being in the cell,
- $W_B$  = grams of mercury required to fill the portion of the cell not occupied by the prepared bed of cement in the cell, and
- $D$  = density of mercury at the temperature of test, Mg/m<sup>3</sup> (see **Table 1**).

**4.2.3** Make at least two determinations of bulk volume of cement, using separate compactions for each determination. The bulk volume value used for subsequent calculations shall be the average of two values agreeing within  $\pm 0.005$  cm<sup>3</sup>. Note the temperature in the vicinity of the cell and record at the beginning and end of the determination.

**NOTE 3**—It is not necessary to use the standard sample for the bulk volume determination.

**NOTE 4**—The prepared bed of cement shall be firm. If too loose or if the cement cannot be compressed to the desired volume, adjust the trial quantity of cement used.

**4.3 Preparation of Sample**—Enclose the contents of a vial of the standard cement sample in a jar, approximately 120 cm<sup>3</sup> (4 oz), and shake vigorously for 2 min to fluff the cement and break up lumps or agglomerates. Allow the jar to stand unopened for a further 2 min, then remove the lid and stir gently to distribute throughout the sample the fine fraction that has settled on the surface after fluffing.

**4.4 Mass of Sample**—The mass of the standard sample used for the calibration test shall be that required to produce a bed of cement having a porosity of  $0.500 \pm 0.005$ , and shall be calculated as follows:

$$W = \rho V(1 - \epsilon) \quad (2)$$

where:

- $W$  = grams of sample required,
- $\rho$  = density of test sample (for portland cement a value of 3.15 Mg/m<sup>3</sup> or 3.15 g/cm<sup>3</sup> shall be used),
- $V$  = bulk volume of bed of cement, cm<sup>3</sup>, as determined in accordance with **4.2**, and
- $\epsilon$  = desired porosity of bed of cement ( $0.500 \pm 0.005$ ) (**Note 5**).

**NOTE 5**—The porosity is the ratio of volume of voids in a bed of cement to the total or bulk volume of the bed,  $V$ .

**4.5 Preparation of Bed of Cement**—Seat the perforated disk on the ledge in the permeability cell, inscribed or marked face down. Place a filter paper disk on the metal disk and press the edges down with a rod having a diameter slightly smaller than that of the cell. Measure the mass to the nearest 0.001 g the quantity of cement determined in accordance with **4.4** and place in the cell. Tap the side of the cell lightly in order to level the bed of cement. Place a filter paper disk on top of the cement and compress the cement with the plunger until the plunger collar is in contact with the top of the cell. Slowly withdraw the

**TABLE 1 Density of Mercury, Viscosity of Air ( $\eta$ ), and  $\sqrt{\eta}$  at Given Temperatures**

Room Temperature, °C	Density of Mercury, Mg/m <sup>3</sup>	Viscosity of Air, $\eta$ $\mu$ Pa·s	$\sqrt{\eta}$
18	13.55	17.98	4.24
20	13.55	18.08	4.25
22	13.54	18.18	4.26
24	13.54	18.28	4.28
26	13.53	18.37	4.29
28	13.53	18.47	4.30
30	13.52	18.57	4.31
32	13.52	18.67	4.32
34	13.51	18.76	4.33

plunger a short distance, rotate about 90°, repress, and then slowly withdraw. Use of fresh paper filter disks is required for each determination.

#### 4.6 Permeability Test:

4.6.1 Attach the permeability cell to the manometer tube, making certain that an airtight connection is obtained (Note 6) and taking care not to jar or disturb the prepared bed of cement.

4.6.2 Slowly evacuate the air in the one arm of the manometer U-tube until the liquid reaches the top mark, and then close the valve tightly. Start the timer when the bottom of the meniscus of the manometer liquid reaches the second (next to the top) mark and stop when the bottom of the meniscus of liquid reaches the third (next to the bottom) mark. Note the time interval measured and record in seconds. Note the temperature of test and record in degrees Celsius.

4.6.3 In the calibration of the instrument, make at least three determinations of the time of flow on each of three separately prepared beds of the standard sample (Note 7). The calibration shall be made by the same operator who makes the fineness determination.

NOTE 6—A little stopcock grease should be applied to the standard taper connection. The efficiency of the connection can be determined by attaching the cell to the manometer, stoppering it, partially evacuating the one arm of the manometer, then closing the valve. Any continuous drop in pressure indicates a leak in the system.

NOTE 7—The sample may be refluffed and reused for preparation of the test bed, provided that it is kept dry and all tests are made within 4 h of the opening of the sample.

4.7 Recalibration—The apparatus shall be recalibrated (Note 8):

4.7.1 At periodic intervals, the duration of which shall not exceed 2½ years, to correct for possible wear on the plunger or permeability cell, or upon receipt of evidence that the test is not providing data in accordance with the precision and bias statement in Section 8.

4.7.2 If any loss in the manometer fluid occurs, recalibrate starting with 4.5, or

4.7.3 If a change is made in the type or quality of the filter paper used for the tests.

NOTE 8—It is suggested that a secondary sample be prepared and used as a fineness standard for the check determinations of the instrument between regular calibrations with the standard cement sample.

## 5. Procedure

5.1 *Temperature of Cement*—The cement sample shall be at room temperature when tested.

5.2 *Size of Test Sample*—The weight of sample used for the test shall be the same as that used in the calibration test on the standard sample, with these exceptions: When determining the fineness of Type III or other types of fine-ground portland cement whose bulk for this mass is so great that ordinary thumb pressure will not cause the plunger collar to contact the top of the cell, the weight of the sample shall be that required to produce a test bed having a porosity of  $0.530 \pm 0.005$ . When determining the fineness of materials other than portland cement, or if for a portland cement sample one of the required porosities cannot be attained, the mass of the sample shall be adjusted so that a firm, hard bed is produced by the compacting process. In no case, however, shall more than thumb pressure

be used to secure the proper bed, nor shall such thumb pressure be used that the plunger “rebounds” from the cell top when pressure is removed.

5.3 *Preparation of Bed of Cement*—Prepare the test bed of cement in accordance with the method described in 4.5.

5.4 *Permeability Tests*—Make the permeability tests in accordance with the method described in 4.6, except that only one time-of-flow determination need be made on each bed.

## 6. Calculation

6.1 Calculate the specific surface values in accordance with the following equations:

$$S = \frac{S_s \sqrt{T}}{\sqrt{T_s}} \quad (3)$$

$$S = \frac{S_s \sqrt{\eta_s} \sqrt{T}}{\sqrt{T_s} \sqrt{\eta}} \quad (4)$$

$$S = \frac{S_s (b - \epsilon_s) \sqrt{\epsilon^3} \sqrt{T}}{\sqrt{\epsilon_s^3} \sqrt{T_s} (b - \epsilon)} \quad (5)$$

$$S = \frac{S_s (b - \epsilon_s) \sqrt{\epsilon^3} \sqrt{\eta} \sqrt{T}}{\sqrt{\epsilon_s^3} \sqrt{T_s} \sqrt{\eta} (b - \epsilon)} \quad (6)$$

$$S = \frac{S_s \rho_s (b_s - \epsilon_s) \sqrt{\epsilon^3} \sqrt{T}}{\rho (b - \epsilon) \sqrt{\epsilon_s^3} \sqrt{T_s}} \quad (7)$$

$$S = \frac{S_s \rho_s (b_s - \epsilon_s) \sqrt{\eta_s} \sqrt{\epsilon^3} \sqrt{T}}{\rho (b - \epsilon) \sqrt{\epsilon_s^3} \sqrt{T_s} \sqrt{\eta}} \quad (8)$$

where:

- $S$  = specific surface of the test sample,  $\text{m}^2/\text{kg}$ ,
- $S_s$  = specific surface of the standard sample used in calibration of the apparatus,  $\text{m}^2/\text{kg}$  (Note 9),
- $T$  = measured time interval, s, of manometer drop for test sample (Note 10),
- $T_s$  = measured time interval, s, of manometer drop for standard sample used in calibration of the apparatus (Note 10),
- $\eta$  = viscosity of air, micro pascal seconds ( $\mu\text{Pa}\cdot\text{s}$ ), at the temperature of test of the test sample (Note 10),
- $\eta_s$  = viscosity of air, micro pascal seconds ( $\mu\text{Pa}\cdot\text{s}$ ), at the temperature of test of the standard sample used in calibration of the apparatus (Note 10),
- $\epsilon$  = porosity of prepared bed of test sample (Note 10),
- $\epsilon\epsilon_s$  = porosity of prepared bed of standard sample used in calibration of apparatus (Note 10),
- $\rho$  = density of test sample (for portland cement a value of  $3.15 \text{ Mg}/\text{m}^3$  or  $3.15 \text{ g}/\text{cm}^3$  shall be used),
- $\rho_s$  = density of standard sample used in calibration of apparatus (assumed to be  $3.15 \text{ Mg}/\text{m}^3$  or  $3.15 \text{ g}/\text{cm}^3$ ),
- $b$  = a constant specifically appropriate for the test sample (for hydraulic cement a value of 0.9 shall be used), and
- $b_s$  = 0.9, the appropriate constant for the standard sample.

NOTE 9—Upon purchase of SRM 114 series samples, a certificate comes with them that indicates the proper specific surface value.

NOTE 10—Values for  $\sqrt{\eta}$ ,  $\sqrt{\epsilon^3}$ , and  $\sqrt{T}$  may be taken from Tables 1-3, respectively.

**TABLE 2 Values for Porosity of Cement Bed**

Porosity of Bed, $\epsilon$	$\sqrt{\epsilon^3}$
0.496	0.349
0.497	0.350
0.498	0.351
0.499	0.352
0.500	0.354
0.501	0.355
0.502	0.356
0.503	0.357
0.504	0.358
0.505	0.359
0.506	0.360
0.507	0.361
0.508	0.362
0.509	0.363
0.510	0.364
0.525	0.380
0.526	0.381
0.527	0.383
0.528	0.384
0.529	0.385
0.530	0.386
0.531	0.387
0.532	0.388
0.533	0.389
0.534	0.390
0.535	0.391

6.1.1 Eq 3 and 4 shall be used in calculations of fineness of portland cements compacted to the same porosity as the standard fineness sample. Eq 3 is used if the temperature of test of the test sample is within  $\pm 3$  °C of the temperature of calibration test, and Eq 4 is used if the temperature of test of the test sample is outside of this range.

6.1.2 Eq 5 and 6 shall be used in calculation of fineness of portland cements compacted to some porosity other than that of the standard fineness sample used in the calibration test. Eq 5 is used if the temperature of test of the test sample is within  $\pm 3$  °C of the temperature of calibration test of the standard fineness sample, and Eq 6 is used if the temperature of test of the test sample is outside of this range.

6.1.3 Eq 7 and 8 shall be used in calculation of fineness of materials other than portland cement. Eq 7 shall be used when the temperature of test of the test sample is within  $\pm 3$  °C of the temperature of calibration test, and Eq 8 is used if the temperature of test of the test sample is outside of this range.

6.1.4 It is recommended that values of  $b$  be determined on no less than three samples of the material in question. Test each sample at a minimum of four different porosities over a porosity range of at least 0.06. Correlation coefficients should exceed 0.9970 for the correlation of  $\sqrt{\epsilon^3 T}$  versus  $\epsilon$  on each sample tested (see Appendix X1).

6.2 To calculate the specific surface values in square metres per kilogram, multiply the surface area in  $\text{cm}^2/\text{g}$  by the factor of 0.1.

6.3 Round values in  $\text{cm}^2/\text{g}$  to the nearest 10 units (in  $\text{m}^2/\text{kg}$  to the nearest unit). Example:  $3447 \text{ cm}^2/\text{g}$  is rounded to  $3450 \text{ cm}^2/\text{g}$  or  $345 \text{ m}^2/\text{kg}$ .

## 7. Report

7.1 For portland cements and portland cement-based materials, report results on a single determination on a single bed.

7.2 For very high fineness materials with long time intervals, report the average fineness value of two permeability tests, provided that the two agree within 2 % of each other. If they do not agree, discard the values and repeat the test (Note 11) until two values so agreeing are obtained.

NOTE 11—Lack of agreement indicates a need for checks of procedure and apparatus. See also the “Manual of Cement Testing.”

## 8. Precision and Bias

8.1 *Single-Operator Precision*—The single-operator coefficient of variation for portland cements has been found to be 1.2 % (Note 12). Therefore, results of two properly conducted tests, by the same operator, on the same sample, should not differ by more than 3.4 % (Note 12) of their average.

8.2 *Multilaboratory Precision*—The multilaboratory coefficient of variation for portland cements has been found to be 2.1 % (Note 12). Therefore, results of two different laboratories on identical samples of a material should not differ from each other by more than 6.0 % (Note 12) of their average.

NOTE 12—These numbers represent, respectively, the 1s % and d2s % limits as described in Practice C 670.

8.3 Since there is no accepted reference material suitable for determining any bias that may be associated with Test Method C 204, no statement is being made.

## TEST METHOD B: AUTOMATED APPARATUS

### 9. Apparatus

9.1 The automated test method shall employ apparatus designed either on the principles of the Blaine air-permeability method (See Note 13) or apparatus based on the air-permeability principles of the Lea and Nurse method (See Note 14).

NOTE 13—Automated apparatus is generally equipped with a micro-processor capable of operating the measuring devices, calculating and displaying the test results. Commercially available units may have significantly different dimensions for manometer and cement bed than those specified by standard methods.

NOTE 14—The Lea and Nurse constant flow rate air permeability method is described in BS 4359: 1971.

### 10. Calibration of Apparatus

10.1 Follow the manufacturer’s directions for calibrating the apparatus (See Note 15). If the apparatus is equipped with more than one cell, each cell will require a separate calibration. The manufacturer’s procedure shall detail the method for bed preparation and the steps required to initiate the automated measurement. It is essential that the procedure be followed precisely and consistently for all tests.

NOTE 15—The manufacturer of the apparatus will generally provide standard samples that can be used for calibration.

### 11. Procedure

11.1 *Temperature of Cement*—The cement sample shall be at room temperature when tested.

**TABLE 3 Time of Airflow**  
 $T$  = time of airflow in seconds;  $\sqrt{T}$  = the factor for use in the equations

$T$	$\sqrt{T}$	$T$	$\sqrt{T}$	$T$	$\sqrt{T}$	$T$	$\sqrt{T}$	$T$	$\sqrt{T}$	$T$	$\sqrt{T}$
26	5.10	51	7.14	76	8.72	101	10.05	151	12.29	201	14.18
26½	5.15	51½	7.18	76½	8.75	102	10.10	152	12.33	202	14.21
27	5.20	52	7.21	77	8.77	103	10.15	153	12.37	203	14.25
27½	5.24	52½	7.25	77½	8.80	104	10.20	154	12.41	204	14.28
28	5.29	53	7.28	78	8.83	105	10.25	155	12.45	205	14.32
28½	5.34	53½	7.31	78½	8.86	106	10.30	156	12.49	206	14.35
29	5.39	54	7.35	79	8.89	107	10.34	157	12.53	207	14.39
29½	5.43	54½	7.38	79½	8.92	108	10.39	158	12.57	208	14.42
30	5.48	55	7.42	80	8.94	109	10.44	159	12.61	209	14.46
30½	5.52	55½	7.45	80½	8.97	110	10.49	160	12.65	210	14.49
31	5.57	56	7.48	81	9.00	111	10.54	161	12.69	211	14.53
31½	5.61	56½	7.52	81½	9.03	112	10.58	162	12.73	212	14.56
32	5.66	57	7.55	82	9.06	113	10.63	163	12.77	213	14.59
32½	5.70	57½	7.58	82½	9.08	114	10.68	164	12.81	214	14.63
33	5.74	58	7.62	83	9.11	115	10.72	165	12.85	215	14.66
33½	5.79	58½	7.65	83½	9.14	116	10.77	166	12.88	216	14.70
34	5.83	59	7.68	84	9.17	117	10.82	167	12.92	217	14.73
34½	5.87	59½	7.71	84½	9.19	118	10.86	168	12.96	218	14.76
35	5.92	60	7.75	85	9.22	119	10.91	169	13.00	219	14.80
35½	5.96	60½	7.78	85½	9.25	120	10.95	170	13.04	220	14.83
36	6.00	61	7.81	86	9.27	121	11.00	171	13.08	222	14.90
36½	6.04	61½	7.84	86½	9.30	122	11.05	172	13.11	224	14.97
37	6.08	62	7.87	87	9.33	123	11.09	173	13.15	226	15.03
37½	6.12	62½	7.91	87½	9.35	124	11.14	174	13.19	228	15.10
38	6.16	63	7.94	88	9.38	125	11.18	175	13.23	230	15.17
38½	6.20	63½	7.97	88½	9.41	126	11.22	176	13.27	232	15.23
39	6.24	64	8.00	89	9.43	127	11.27	177	13.30	234	15.30
39½	6.28	64½	8.03	89½	9.46	128	11.31	178	13.34	236	15.36
40	6.32	65	8.06	90	9.49	129	11.36	179	13.38	238	15.43
40½	6.36	65½	8.09	90½	9.51	130	11.40	180	13.42	240	15.49
41	6.40	66	8.12	91	9.54	131	11.45	181	13.45	242	15.56
41½	6.44	66½	8.15	91½	9.57	132	11.49	182	13.49	244	15.62
42	6.48	67	8.19	92	9.59	133	11.53	183	13.53	246	15.68
42½	6.52	67½	8.22	92½	9.62	134	11.58	184	13.56	248	15.75
43	6.56	68	8.25	93	9.64	135	11.62	185	13.60	250	15.81
43½	6.60	68½	8.28	93½	9.67	136	11.66	186	13.64	252	15.87
44	6.63	69	8.31	94	9.70	137	11.70	187	13.67	254	15.94
44½	6.67	69½	8.34	94½	9.72	138	11.75	188	13.71	256	16.00
45	6.71	70	8.37	95	9.75	139	11.79	189	13.75	258	16.06
45½	6.75	70½	8.40	95½	9.77	140	11.83	190	13.78	260	16.12
46	6.78	71	8.43	96	9.80	141	11.87	191	13.82	262	16.19
46½	6.82	71½	8.46	96½	9.82	142	11.92	192	13.86	264	16.25
47	6.86	72	8.49	97	9.85	143	11.96	193	13.89	266	16.31
47½	6.89	72½	8.51	97½	9.87	144	12.00	194	13.93	268	16.37
48	6.93	73	8.54	98	9.90	145	12.04	195	13.96	270	16.43
48½	6.96	73½	8.57	98½	9.92	146	12.08	196	14.00	272	16.49
49	7.00	74	8.60	99	9.95	147	12.12	197	14.04	274	16.55
49½	7.04	74½	8.63	99½	9.97	148	12.17	198	14.07	276	16.61
50	7.07	75	8.66	100	10.00	149	12.21	199	14.11	278	16.67
50½	7.11	75½	8.69	100½	10.02	150	12.25	200	14.14	280	16.73

11.2 *Size of the Test Sample*—The mass of the sample used for the test shall be the same as used in the calibration test unless cements of different density or porosity are to be tested and then follow the manufacturer’s guidelines for adjusting mass.

11.3 *Permeability Tests*—Make permeability tests using the same procedure used for the calibration tests. Only one determination need be made for each bed preparation.

## 12. Performance Requirement (Qualification) for the Automated Apparatus

12.1 *Scope*—When the specific surface values determined by an automated apparatus are to be used for acceptance or rejection of cement, the method used shall comply with the qualification requirements of this section. A method is considered to consist of the specific instrument and testing procedure

meeting the requirements of this standard and used in a consistent manner by a given laboratory.

12.2 *Samples*—Select two cement samples that have surface area and density that bracket the desired test range. The range of the surface area shall not exceed 2000 cm<sup>2</sup>/g (200 m<sup>2</sup>/kg) and shall have densities that differ no more than 0.06 g/cm<sup>3</sup> (60 Mg/m<sup>3</sup>).

12.3 *Tests*—Make triplicate determinations on each cement sample following Test Method A (Reference Method). On the same day, complete a second round of triplicate tests using the method to be qualified (Test Method B) and including the standardization formula described in this section. Prepare a new cell bed and repeat all the steps of the test procedures for each determination. Report values to the nearest 10 cm<sup>2</sup>/g (1 m<sup>2</sup>/kg).

12.4 *Calculations*—Calculate the range and the mean of the three replicate tests for each method and each cement. A method complies with the qualification requirements if the absolute difference between the average value of Test Method A and the corresponding average value for Test Method B (each with three replicates) is not greater than 2.7 % of the Test Method A average (See **Note 16**) and the range for any three replicate tests does not exceed 4.0 % of the average (See **Note 17**). The method is qualified only if both cement samples shall meet the above requirements. Example qualification data are given in **Appendix X2**.

**NOTE 16**—This value represents the least-significant-difference (LSD) for 95 % confidence as applied to the coefficient of variation of 1.2 % (Single-Operator-Precision) for Test Method A, given in section 8.1. The equation is:

$$LSD(95\%) = t_{0.05, df} [(2CV^2/n)]^{1/2} \quad (9)$$

where:

- $df$  = 4, degree of freedom, two from each of the two sets of results
- $n$  = 3, the number of replicates
- $CV$  = 1.2 %, the Single-Operator-Precision, and
- $t_{0.05, 4}$  = 2.776, Students-t statistic for a 5 % probability with a  $df = 4$ .

**NOTE 17**— This value represents the  $d_{2s}$  % calculation for 3 replicates in accordance with Table 1 of Practice **C 670** and applied to the coefficient

of variation of 1.2 % (Single-Operator-Precision) for Test Method A, given in section 8.1.

12.5 *Standardization*:

12.5.1 When standardization is required in order to achieve agreement between Test Method A and Test Method B, standardize the apparatus as follows:

12.5.1.1 Prepare a separate standardization for each type of cement to be tested, using reference samples of density within 0.06 g/cm<sup>3</sup> (60 Mg/m<sup>3</sup>) of the cement to be tested, and packed to the same bed porosity.

12.5.1.2 For each standardization, obtain five reference samples with a minimum air permeability fineness range of 800 cm<sup>2</sup>/g (80 m<sup>2</sup>/kg) and a minimum difference between samples of 50 cm<sup>2</sup>/g (5 m<sup>2</sup>/kg). If cement samples used for qualification are used, make new determinations. Use the same method as used for the instrument qualification and follow all the steps. Valid standardization formulas shall be mathematically derived and applied to all samples.

### 13. Requalification of a Method

13.1 Requalify the method at least once per year and when any of the following conditions occur:

13.1.1 The instrument has been significantly modified.

13.1.2 The instrument has been substantially repaired.

13.1.3 Substantial evidence indicates that the method is not providing data meeting the performance requirements.

13.1.4 The average of a Cement and Concrete Reference Laboratory (CCRL) proficiency test sample differs from the value obtained by the method by more than 6 %.

### 14. Precision and Bias

14.1 *Precision*—No precision data are available at this time. Based on qualification requirements, the precision of the method should not be greater than that of Test Method A

14.2 *Bias*—Since there are no acceptable reference materials suitable for determining any bias that may be associated with Test Methods C 204, no statement on bias is presented.

### 15. Keywords

15.1 air-permeability; apparatus; fineness

APPENDIXES

(Nonmandatory Information)

XI. ILLUSTRATIVE METHOD FOR THE DETERMINATION OF THE VALUE FOR THE CONSTANT *b*

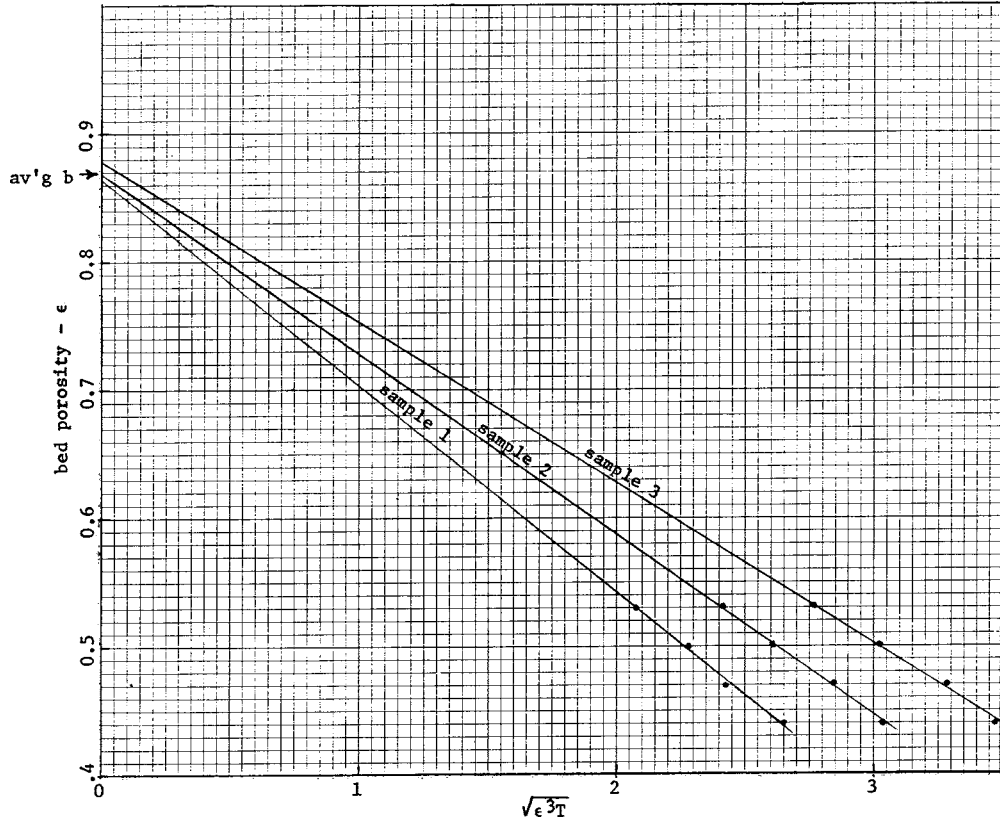

	$\epsilon$	$W$	$T$	$\sqrt{\epsilon^3 T}$
Material: Silica flour $\rho$ = density of test sample = 2.65 Mg/m <sup>3</sup> $V$ = bulk volume of sample bed = 1.887 cm <sup>3</sup> $\epsilon$ = desired porosity of test $W$ = grams of sample required = $\rho V(1 - \epsilon)$ $T$ = measured test time interval, seconds			Sample 1	
	0.530	2.350	29.0	2.078
	0.500	2.500	42.0	2.291
	0.470	2.650	57.5	2.443
	0.440	2.800	82.5	2.651
Computed values of <i>b</i> by linear regression:			Sample 2	
	0.530	2.350	39.0	2.410
	0.500	2.500	55.5	2.634
	0.470	2.650	79.0	2.864
	0.440	2.800	108.5	3.040
Sample 1 <i>b</i> = 0.863 (correlation coefficient = 0.9980) Sample 2 <i>b</i> = 0.869 (correlation coefficient = 0.9993) Sample 3 <i>b</i> = 0.879 (correlation coefficient = 0.9973) Average <i>b</i> = 0.870			Sample 3	
	0.530	2.350	51.5	2.769
	0.500	2.500	73.0	3.021
	0.470	2.650	104.0	3.286
	0.440	2.800	141.5	3.472

FIG. X1.1 Illustrative Method for the Determination of the Value for the Constant *b* (for use in fineness calculations of materials other than portland cement)



**X2. SAMPLE QUALIFICATION RESULTS**
**TABLE X2.1 Sample Qualification Results**

Cement	Tests	Test Method A cm <sup>2</sup> /g (m <sup>2</sup> /kg)	Test Method B cm <sup>2</sup> /g (m <sup>2</sup> /kg)	Difference
A	1	3120 (312)	3130 (313)	
A	2	3130 (313)	3160 (316)	
A	3	3090 (309)	3140 (314)	
	Avg.	3113 (311.3)	3143 (314.3)	30
	Range Max.	40 (4)	30 (3)	
	4.0 % of Avg.	1.3 % (Pass)	1.0 % (Pass)	
	Max. Difference		(30 × 100)/3113 =	
	2.7 % of Test Method A Avg.		or	
			3 × 100)/311.3 =	0.9 % (Pass)
<hr/>				
Cement	Tests	Test Method A cm <sup>2</sup> /g (m <sup>2</sup> /kg)	Test Method B cm <sup>2</sup> /g (m <sup>2</sup> /kg)	Difference
B	1	4180 (418)	4160 (416)	
B	2	4030 (403)	4150 (415)	
B	3	4060 (406)	4210 (421)	
	Avg.	4090 (409.0)	4173 (417.3)	83
	Range Max.	150	60	
	4.0 % of Avg.	3.7 % (Pass)	1.4 % (Pass)	
	Max. Difference		(83 × 100)/4090 =	2.0 % (Pass)
	2.7 % of Test Method A Avg.		or	
			(8.3 × 100)/409 =	

**SUMMARY OF CHANGES**

Committee C01 has identified the location of selected changes to these test methods since the last issue, C 204 – 05, that may impact the use of these test methods. (Approved August 1, 2007)

(I) Revised 3.6 and 3.7.

*ASTM International takes no position respecting the validity of any patent rights asserted in connection with any item mentioned in this standard. Users of this standard are expressly advised that determination of the validity of any such patent rights, and the risk of infringement of such rights, are entirely their own responsibility.*

*This standard is subject to revision at any time by the responsible technical committee and must be reviewed every five years and if not revised, either reapproved or withdrawn. Your comments are invited either for revision of this standard or for additional standards and should be addressed to ASTM International Headquarters. Your comments will receive careful consideration at a meeting of the responsible technical committee, which you may attend. If you feel that your comments have not received a fair hearing you should make your views known to the ASTM Committee on Standards, at the address shown below.*

*This standard is copyrighted by ASTM International, 100 Barr Harbor Drive, PO Box C700, West Conshohocken, PA 19428-2959, United States. Individual reprints (single or multiple copies) of this standard may be obtained by contacting ASTM at the above address or at 610-832-9585 (phone), 610-832-9555 (fax), or service@astm.org (e-mail); or through the ASTM website (www.astm.org).*