



Standard Test Methods for Cellulosic Fiber Insulating Board¹

This standard is issued under the fixed designation C 209; the number immediately following the designation indicates the year of original adoption or, in the case of revision, the year of last revision. A number in parentheses indicates the year of last approval. A superscript epsilon (ε) indicates an editorial change since the last revision or reapproval.

This standard has been approved for use by agencies of the Department of Defense.

^{ε1} NOTE—Footnote 4 was editorially updated in August 2007.

1. Scope

1.1 These test methods cover those insulation products in specified Specification C 208 that are not singularly specified elsewhere as insulating formboard (see Specification C 532) and nail-base sheathing (see Specification D 2277). The requirements for the products' physical properties are specified in Specification C 208. The methods for the general insulation products' physical properties are given as follows:

	Section
Thickness	7
Size of Finished Board	8
Thermal Conductivity	9
Transverse Strength	10
Deflection at Specified Minimum Load	11
Tensile Strength Parallel to Surface	12
Tensile Strength Perpendicular to Surface	13
Water Absorption	14
Linear Expansion	15
Water Vapor Transmission	16
Flame Spread Index	17
Moisture Content and Density	18

1.2 Reference is provided to an established source for nomenclature and definitions.

1.3 *This standard does not purport to address all of the safety concerns, if any, associated with its use. It is the responsibility of the user of this standard to establish appropriate safety and health practices and determine the applicability of regulatory limitations prior to use.*

1.4 Several of the test methods contained in this document are referenced by material specifications other than cellulosic

fiber insulating board. These include mineral fiber, perlite, polyisocyanurate, polystyrene and phenolic materials.

2. Referenced Documents

2.1 ASTM Standards:²

- C 168 Terminology Relating to Thermal Insulation
- C 177 Test Method for Steady-State Heat Flux Measurements and Thermal Transmission Properties by Means of the Guarded-Hot-Plate Apparatus
- C 208 Specification for Cellulosic Fiber Insulating Board
- C 518 Test Method for Steady-State Thermal Transmission Properties by Means of the Heat Flow Meter Apparatus
- C 532 Specification for Structural Insulating Formboard (Cellulosic Fiber)³
- C 870 Practice for Conditioning of Thermal Insulating Materials
- C 1045 Practice for Calculating Thermal Transmission Properties Under Steady-State Conditions
- C 1114 Test Method for Steady-State Thermal Transmission Properties by Means of the Thin-Heater Apparatus
- D 1037 Test Methods for Evaluating Properties of Wood-Base Fiber and Particle Panel Materials
- D 1554 Terminology Relating to Wood-Base Fiber and Particle Panel Materials
- D 2277 Specification for Fiberboard Nail-Base Sheathing³
- E 84 Test Method for Surface Burning Characteristics of Building Materials

¹ These test methods are under the jurisdiction of ASTM Committee C16 on Thermal Insulation and are the direct responsibility of Subcommittee C16.32 on Mechanical Properties.

Current edition approved May 1, 2007. Published June 2007. Originally approved in 1946. Last previous edition approved in 2007 as C 209 – 07.

² For referenced ASTM standards, visit the ASTM website, www.astm.org, or contact ASTM Customer Service at service@astm.org. For *Annual Book of ASTM Standards* volume information, refer to the standard's Document Summary page on the ASTM website.

³ Withdrawn.

E 96/E 96M Test Methods for Water Vapor Transmission of Materials

3. Terminology

3.1 *Definitions*—The definitions of terms used in these methods shall be in accordance with Definitions **D 1554** and Terminology **C 168**.

3.2 *cellulosic fiber insulating board*—a fibrous-felted, homogeneous panel made from ligno-cellulosic fibers (usually wood or cane) and having a density of less than 31 lb/ft³ (497 kg/m³) but more than 10 lb/ft³ (160 kg/m³).

3.2.1 *Discussion*—Cellulosic fiber insulating board. It is characterized by an integral bond that is produced by interfelting of the fibers, but which has not been consolidated under heat and pressure as a separate stage in manufacture. Other materials may be added during manufacture to improve certain properties.

3.3 *Definitions of Terms Specific to This Standard:*

3.3.1 *board*—refers to the material as received.

3.3.2 *sample*—refers to the 36 by 48-in. (0.9 by 1.2-m) piece cut from a board.

3.3.3 *test specimen*—refers to the test piece cut from a sample unless otherwise specified in the test method.

3.3.4 *sorption*—a general term in physical chemistry used to describe the combined processes of:

(1) *absorption*—refers to the taking up of matter in bulk by other matter, for example, the penetration of substances into the bulk of another solid or liquid.

(2) *adsorption*—refers to surface retention or adhesion of an extremely thin layer of molecules to the surfaces of solids or liquids with which they are in contact.

4. Significance and Use

4.1 The test methods contained in this document are intended for cellulosic fiber insulating board as described in Specification **C 208**. These test methods examine mechanical, physical and thermal properties, properties related to water absorption and water vapor exposure, and flammability related properties.

4.2 The results of these tests may be used to describe the performance of insulating board and are suitable for use in material specifications.

NOTE 1—Committee C-16 is in the process of splitting this document into discrete test methods categorized by the nature of the test methods.

5. Sampling

5.1 *Selection of Boards*—Refer to Specification **C 208**, Section 9 on Sampling.

5.2 *Size of Sample*—From each board a sample, 36 by 48 in. (0.9 by 1.2 m) shall be cut. When possible, the larger dimension of the sample shall be crosswise of the longer dimension of the board as it is usually obtained. When the individual boards are less than 36 by 48 in. (0.9 by 1.2 m) in size, enough material shall be taken to give the equivalent area.

6. Test Conditions

6.1 *Preconditioning*—Tests shall be made under prevailing atmospheric conditions except in the case of dispute. Tests then

shall be made in specimens conditioned until equilibrium is obtained in accordance with Practice **C 870**.

7. Thickness

7.1 *Apparatus*—An instrument such as a dial gage capable of measuring a 36 by 48 in. (0.9 by 1.2 m) sample, on which the contacting surfaces are flat and have a minimum diameter of ½ in. (13 mm) shall be used. Pressure on the contacting surfaces shall not be greater than 1 psi (6.9 kPa) nor less than 0.25 psi (1.7 kPa), and the instrument shall read to an accuracy of 0.001 in. (0.03 mm).

7.2 *Procedure*—Measure the thickness at five points, near each corner and near the center, to an accuracy of ±0.001 in. (±0.02 mm). Take care that the sample is not deformed when the thickness measurements are taken.

7.3 *Calculation and Report*—Report the average of the five measurements as the average thickness of the sample. Report as the average thickness of the sample, the average thickness of the lot, report thickness tolerance, as follows:

$$\text{Thickness tolerance} = (h_1 - h_2)/h_1 \quad (1)$$

where:

h_1 = average thickness of lot, and

h_2 = average thickness of sample.

8. Size of Finished Board

8.1 *Procedure*—Obtain the average width of the finished board by measuring the width at each end and at the middle to an accuracy of ±0.3 % or ¼ in. (2 mm), whichever is smaller, and averaging these readings. Obtain the average length of the finished board in a similar manner.

9. Thermal Conductivity

9.1 *Procedure*—Determine thermal conductivity in accordance with Test Method **C 177**, or in accordance with Test Methods **C 518**, **C 1045** or **C 1114**. Test two specimens from one sample from one board.

10. Transverse Strength

10.1 *Apparatus:*

10.1.1 *Testing Machine*—Any standard mechanical or hydraulic testing machine capable of applying and measuring the required load within an accuracy of ±2 % may be used.

10.1.2 *Bearing Edges*—The bearing edges shall be rounded to a radius of ⅜ in. (10 mm) to prevent injury to the specimen. The bearing edges shall be straight and shall maintain full contact with the specimen throughout the test.

10.2 *Test Specimen*—The specimen shall be 3 by 15 in. (76 by 381 mm) and conditioned in accordance with 6.1. Three specimens from the long dimension of each sample from each board and three at right angles shall be tested. If the sample has a dimension less than 15 in. (381 mm), test only in that direction for which a 15 in. (381 mm) specimen can be obtained.

10.3 *Procedure*—Determine the transverse load by placing the specimen on horizontal bearing edges 12 in. (305 mm) apart and applying the load at midspan on a bearing parallel to the end supports, so that the head of the testing machines,

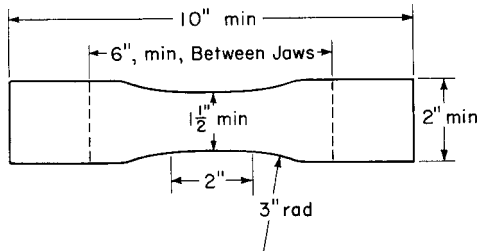

SI Equivalents

in.	mm	in.	mm
10	254	2	51
6	152	1½	38
3	76		

FIG. 1 Specimen for Determination of Tensile Strength Parallel to Surface

through which the load is applied, moves at a rate of 6 ± 2 in./min (152 ± 51 mm/min) until failure occurs.

10.4 *Calculation and Report*—Report as the transverse load for specimen, the maximum load reached during the test. Report as the average transverse load in pounds-force (or Newtons) in each direction for a sample, the average of three specimens taken from that direction. Report as the total average transverse load in each direction, the average of all samples in that direction. Calculate modulus of rupture values in pounds-force per square inch (or megapascals) as follows:

$$MOR = 6Pt^2 \quad (2)$$

where:

- MOR = Modulus of rupture, psi (MPa),
- P = Transverse load, lbf (N), and
- t = thickness, in. (mm).

10.5 *Precision and Bias*—See Section 19.

11. Deflection at Specific Minimum Load

11.1 *Procedure*—Determine, to the nearest 0.01 in., (0.3 mm) the deflection at the corner of each specimen subjected to the minimum transverse load, by means of a suitable measuring device such as a dial gage under the specimen, a steel rule alongside the specimen, or measurement of the crosshead movement.

11.2 *Calculation and Report*—Report as the average deflection in each direction for a sample, the average of three specimens taken from that direction. Report as the total average deflection in each direction, the average of all samples in that direction.

11.3 *Precision and Bias*—See Section 19.

12. Tensile Strength Parallel to Surface

12.1 *Apparatus*—Any standard mechanical or hydraulic testing machine capable of applying and measuring the required load within an accuracy of $\pm 2\%$ may be used.

12.2 *Test Specimen*—Specimens shall be prepared in accordance with Fig. 1, and conditioned in accordance with 6.1. Three specimens from the long direction of each sample from each board and three at right angles thereto shall be tested.

12.3 *Procedure*—Set the testing machine for a rate of separation of the jaws of $2 \pm \frac{1}{4}$ in./min (51 ± 6 mm/min).

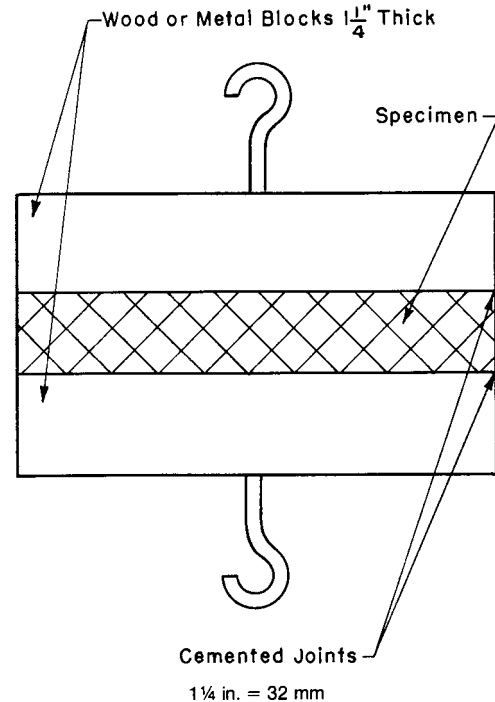

FIG. 2 Apparatus for Determination of Tensile Strength Perpendicular to Surface

Clamp the specimens in the jaws at a minimum distance of 6 in. (152 mm) apart. Specimens breaking within $\frac{1}{2}$ in. (13 mm) of the jaws shall be disregarded. Measure the specimens, after breaking, for width and thickness at the break to the nearest 0.01 in. (0.3 mm).

12.4 *Calculation and Report*—Report as the average tensile strength in each direction for a sample, the average, in pounds-force per square inch (or kilopascals), of the three specimens taken from that direction. Report as the total average value in each direction, the average of all samples in that direction.

12.5 *Precision and Bias*—See Section 19.

13. Tensile Strength Perpendicular to Surface

13.1 *Apparatus*—The apparatus shall be as shown in Fig. 2 and shall consist of two blocks 2 by 2 by $\frac{1}{4}$ in. (51 by 51 by 32 mm) supplied with hooks in the center as shown in Fig. 2. Any standard mechanical or hydraulic testing machine capable of applying and measuring the required load within an accuracy of $\pm 2\%$ may be used.

13.2 *Test Specimens*—The specimen shall be cut to match the lateral dimensions of the test block in 13.1 and conditioned in accordance with 6.1. Two specimens shall be tested, one each from the sample from two boards.

13.3 *Procedure*—Cement the two surfaces of the specimens to the blocks with a suitable adhesive. After the adhesive has set a sufficient length of time, apply a load at the rate of $2 \pm \frac{1}{4}$ in./min (51 ± 6 mm/min) at the hooks until separation within the block.

13.4 *Calculation and Report*—Report the tensile strength perpendicular to the surfaces as the average of the loads in

pounds-force per square foot (or kilopascals) at the time of failure of the test specimens. Note the location of the line of failure.

13.5 *Precision and Bias*—See Section 19.

14. Water Absorption

14.1 *Pan*—A pan or vessel not less than 15 by 15 in. (381 by 381 mm) and of the required depth.

14.1.1 *Conditioning Oven or Room*—A conditioning oven or room that can be regulated to a temperature of $73.8 \pm 4^\circ\text{F}$ ($23 \pm 2^\circ\text{C}$) and a relative humidity of $50 \pm 5\%$.

14.1.2 *Thermometer*—An ordinary thermometer graduated in Fahrenheit or Celsius degrees.

14.2 *Test Specimen*—The specimen shall be 12 by 12 in. (305 by 305 mm) with all four edges trimmed square. Three specimens shall be tested, one each from the sample from three boards.

14.3 *Procedure*—Condition the specimen until the practical constant weight is obtained at a temperature of $73.4 \pm 4^\circ\text{F}$ ($23 \pm 2^\circ\text{C}$) and a relative humidity of $50 \pm 5\%$. Measure the thickness of the specimen with reasonable accuracy and calculate the volume therefrom. Then carefully weigh the specimen and submerge it horizontally under 1 in. (25 mm) of fresh tap water, maintained at a temperature of $73.4 \pm 4^\circ\text{F}$ ($23 \pm 2^\circ\text{C}$). After 2 h of submersion, place the specimen on end to drain for 10 min; at the end of this time remove the excess surface water by hand with a blotting paper or paper towel, and immediately weigh the specimen. If a 24-h water sorption is required, conduct it in accordance with the appropriate sections of Test Methods D 1037.

14.4 *Calculation and Report*—Calculate and report the amount of water absorbed from the increase in weight of the specimen during the submersion, and the water sorption shall be expressed as the percentage by volume based on the volume after conditioning. The specific gravity of the water shall be assumed to be 1.00 for this purpose.

14.5 *Precision and Bias*—See Section 19.

15. Linear Expansion

15.1 *Procedure*—Determine linear expansion due to change in moisture content in accordance with the appropriate sections of Test Methods D 1037, Section 107. Test one specimen from the long dimension of each sample from each board and one at right angles thereto.

16. Water Vapor Transmission

16.1 *Procedure*—Determine water vapor transmission in accordance with Test Methods E 96, using the desiccant method. Test three specimens, one each from the sample from three boards.

17. Flame Spread Index

17.1 *Procedure*—Determine flame spread index in accordance with Test Method E 84.

18. Moisture Content and Density

18.1 *Scope*—This method covers determination of the absorption of moisture content and density at time of test,

TABLE 1 Transverse Strength (Pounds)

Material	Average	Repeatability Standard Deviation	Reproducibility Standard Deviation	Repeatability Limit	Reproducibility Limit
	\bar{x}	sr	sR	r	R
A	12.831	1.386	1.386	3.881	3.881
B	18.256	1.432	1.432	4.009	4.009
C	13.097	1.501	1.501	4.203	4.203
D	16.562	0.983	1.334	2.751	3.734
E	14.525	2.524	2.598	7.067	7.273

because of their relation to the strength properties. Values of density calculated from the volume and weight are satisfactory for these materials. For normal purposes, the moisture content and density of the transverse test specimens may be used unless special reasons require the testing of additional samples.

18.2 *Procedure*—Weigh, measure, and dry the test specimens as presented in Test Methods D 1037, Section 119.

18.3 *Calculation and Report*:

18.3.1 Calculate the moisture content as shown in Test Methods D 1037, Section 120.

18.3.2 Calculate the density as follows:

$$D = 3.81F/LWT \quad (3)$$

or

$$D = (F)(1 \times 10^6)/L'W'T' \quad (4)$$

where:

D = density, lb/ft³ (D' , kg/m³)

F = final weight, when oven-dry, g,

L = length of coupon, in. (L' , mm),

W = width of coupon, in. (W' , mm), and

T = thickness of coupon, in. (T' , mm).

NOTE 2—The density as determined by this equation is based on volume at test and weight when oven-dry.

18.3.3 Report the moisture content and density for each individual test specimen. Averages should not be used except for test specimens that have been brought to equilibrium under the same conditions.

19. Precision and Bias ⁴

19.1 The precision of this test method is based on an interlaboratory study of C209-98, Standard Test Methods for Cellulosic Fiber Insulating Board, conducted in 2006. Each of six laboratories tested five different materials. Every “test result” represents an individual determination. All laboratories obtained two replicate test results for each material. See Table 1 and Table 2.

19.1.1 *Repeatability*—Two test results obtained within one laboratory shall be judged not equivalent if they differ by more than the “ r ” value for that material; “ r ” is the interval representing the critical difference between two test results for the same material, obtained by the same operator using the same equipment on the same day in the same laboratory.

⁴ Supporting data have been filed at ASTM International Headquarters and may be obtained by requesting Research Report RR: C16-1033

TABLE 2 Modulus of Rupture (psi)

Material	Average	Repeatability Standard Deviation	Reproducibility Standard Deviation	Repeatability Limit	Reproducibility Limit
	\bar{x}	sr	sR	r	R
A	291.667	27.61	32.383	77.309	90.671
B	369.583	21.477	26.828	60.135	75.12
C	339.583	13.859	18.657	38.806	52.24
D	400.083	27.813	36.605	77.877	102.494
E	318.917	61.231	70.984	171.447	198.756

TABLE 3 Modified Modulus of Rupture (psi)

Material	Average	Repeatability Standard Deviation	Reproducibility Standard Deviation	Repeatability Limit	Reproducibility Limit
	\bar{x}	sr	sR	r	R
A	288.000	27.462	34.056	76.894	95.356
B	361.583	21.785	26.127	60.998	73.156
C	327.167	18.207	27.082	50.980	75.829
D	393.583	27.284	37.463	76.395	104.895
E	315.250	61.108	70.905	168.301	198.534

19.1.2 *Reproducibility*—Two test results shall be judged not equivalent if they differ by more than the “*R*” value for that material; “*R*” is the interval representing the difference between two test results for the same material, obtained by different operators using different equipment in different laboratories.

19.1.3 Any judgment in accordance with these two statements would have an approximate 95% probability of being correct.

19.2 *Bias*—There was no accepted reference material suitable for determining the bias for this test method, therefore no statement on bias is being made.

19.3 The precision statement was determined through statistical examination of 180 results, from six laboratories, on five materials.

20. Keywords

20.1 absorption; accepted reference value; accuracy; bias; board; cellulose; deflection; density; expansion; interlaboratory study; length and width; linear changes; moisture content; modulus of rupture; precision; precision conditions; repeatability; reproducibility; standard deviation; tensile strength; thermal conductivity; thermal insulating materials-board; thickness; transmission-water vapor; transverse strength; water absorption

ASTM International takes no position respecting the validity of any patent rights asserted in connection with any item mentioned in this standard. Users of this standard are expressly advised that determination of the validity of any such patent rights, and the risk of infringement of such rights, are entirely their own responsibility.

This standard is subject to revision at any time by the responsible technical committee and must be reviewed every five years and if not revised, either reapproved or withdrawn. Your comments are invited either for revision of this standard or for additional standards and should be addressed to ASTM International Headquarters. Your comments will receive careful consideration at a meeting of the responsible technical committee, which you may attend. If you feel that your comments have not received a fair hearing you should make your views known to the ASTM Committee on Standards, at the address shown below.

This standard is copyrighted by ASTM International, 100 Barr Harbor Drive, PO Box C700, West Conshohocken, PA 19428-2959, United States. Individual reprints (single or multiple copies) of this standard may be obtained by contacting ASTM at the above address or at 610-832-9585 (phone), 610-832-9555 (fax), or service@astm.org (e-mail); or through the ASTM website (www.astm.org).