



Standard Test Methods for Bleeding of Concrete¹

This standard is issued under the fixed designation C 232; the number immediately following the designation indicates the year of original adoption or, in the case of revision, the year of last revision. A number in parentheses indicates the year of last approval. A superscript epsilon (ϵ) indicates an editorial change since the last revision or reapproval.

This standard has been approved for use by agencies of the Department of Defense.

1. Scope*

1.1 These test methods cover the determination of the relative quantity of mixing water that will bleed from a sample of freshly mixed concrete. Two test methods, that differ primarily in the degree of vibration to which the concrete sample is subjected, are included.

1.2 The two test methods are not expected to yield the same test results when samples of concrete from the same batch are tested by each method. When various concretes are to be compared, all the tests must be conducted using the same method, and if the batches are of similar unit weight, the sample masses shall not differ by more than 1 kg (2 lb).

1.3 The values stated in SI units are to be regarded as standard. The values in parentheses are provided for information purposes only.

1.4 The text of this standard references notes and footnotes which provide explanatory material. These notes and footnotes (excluding those in tables and figures) shall not be considered as requirements of the standard.

1.5 *This standard does not purport to address all of the safety concerns, if any, associated with its use. It is the responsibility of the user of this standard to establish appropriate safety and health practices and determine the applicability of regulatory limitations prior to use. (Warning—Fresh hydraulic cementitious mixtures are caustic and may cause chemical burns to skin and tissue upon prolonged exposure).²*

2. Referenced Documents

2.1 ASTM Standards:³

C 138/C 138M Test Method for Density (Unit Weight), Yield, and Air Content (Gravimetric) of Concrete

C 172 Practice for Sampling Freshly Mixed Concrete

C 192/C 192M Practice for Making and Curing Concrete Test Specimens in the Laboratory

C 670 Practice for Preparing Precision and Bias Statements for Test Methods for Construction Materials

3. Significance and Use

3.1 This test method provides procedures to be used for determining the effect of variables of composition, treatment, environment, or other factors in the bleeding of concrete. It is also permitted to be used to determine the conformance of a product or treatment with a requirement relating to its effect on bleeding of concrete.

3.2 *Method A*—For a sample consolidated by rodding only and tested without further disturbance, thus simulating conditions in which the concrete, after placement, is not subjected to intermittent vibration.

3.3 *Method B*—For a sample consolidated by vibration and tested with further intermittent periods of vibration, thus simulating conditions in which concrete, after being placed, is subjected to intermittent vibration.

TEST METHOD A—SAMPLE CONSOLIDATED BY TAMPING

4. Apparatus

4.1 *Container*—A cylindrical container of approximately 14L ($\frac{1}{2}$ -ft³) capacity, having an inside diameter of 255 ± 5 mm ($10 \pm \frac{1}{4}$ in.) and an inside height of 280 ± 5 mm ($11 \pm \frac{1}{4}$ in.). The container shall be made of metal having a thickness of 2.67 to 3.40 mm (0.105 to 0.134 in.) and shall be externally reinforced around the top with a 2.67 to 3.40 mm (0.105 to 0.134 in.) metal band, 40 mm ($1\frac{1}{2}$ in.) wide. The inside shall be smooth and free of corrosion, coatings, or lubricants.

4.2 *Scale*, of sufficient capacity to determine the mass of the load required with an accuracy of 0.5 %. Balances or scales shall be calibrated at least annually or whenever there is reason to question the accuracy of the equipment. Equipment not in operating condition or out of tolerance shall be marked as such and taken out of service until corrected.

4.3 *Pipet*, or similar instrument, for drawing off free water from the surface of the test specimen.

¹ These test methods are under the jurisdiction of ASTM Committee C09 on Concrete and Concrete Aggregates and are the direct responsibility of Subcommittee C09.60 on Testing Fresh Concrete.

Current edition approved July 15, 2007. Published August 2007. Originally approved in 1949. Last previous edition approved in 2004 as C 232 – 04.

² Section on Safety Precautions, Manual of Aggregate and Concrete Testing, *Annual Book of ASTM Standards, Vol 04.02*.

³ For referenced ASTM standards, visit the ASTM website, www.astm.org, or contact ASTM Customer Service at service@astm.org. For *Annual Book of ASTM Standards* volume information, refer to the standard's Document Summary page on the ASTM website.

*A Summary of Changes section appears at the end of this standard.

4.4 *Glass Graduate*, 100-mL capacity for collecting and measuring the quantity of water withdrawn.

4.5 *Tamping Rod*—A round, straight steel rod, 16 mm ($\frac{5}{8}$ in.) in diameter and approximately 610 mm (24 in.) in length, having the tamping end rounded to a hemispherical tip, the diameter of which is 16 mm ($\frac{5}{8}$ in.).

4.6 The apparatus listed in 4.7, 4.8, and 4.9 are required if the procedure of measuring the amount of bleeding water recovered is one involving weighing, evaporation, and reweighing.

4.7 *Metal Beaker (Optional)*—A 1000-mL metal beaker for collecting the decanted supernatant water and sludge.

4.8 *Balance (Optional)*—A balance sensitive to 1 g for determining the mass of the decanted water and sludge.

4.9 *Hot Plate (Optional)*—A small electric hot plate or other source of heat for evaporating decanted water.

5. Test Specimen

5.1 For concrete made in the laboratory, prepare as described in Practice C 192/C 192M. For concrete made in the field, sample the concrete as described in Practice C 172. The apparatus described in this test method is permitted to be used with samples of concrete containing any size of aggregate graded up to and including a nominal maximum size of 50 mm (2 in.). Concrete containing aggregate larger than 50 mm (2 in.) in nominal maximum size shall be wet sieved over a 3.75 mm ($\frac{1}{2}$ -in.) sieve and the test performed on a portion of the sample that passes through the sieve.

5.2 Fill the container with the concrete in accordance with Test Method C 138/C 138M except that the container shall be filled to a height of 254 ± 3 mm ($10 \pm \frac{1}{8}$ in.). Level the top surface of the concrete to a reasonably smooth surface by a minimum amount of troweling.

6. Procedure

6.1 During the test, maintain the ambient temperature between 18 and 24 °C (65 and 75 °F). Immediately after troweling the surface of the specimen, record the time and determine the mass of the container and its contents. Place the specimen and container on a level platform or floor free of noticeable vibration and cover the container to prevent evaporation of the bleed water. Keep the cover in place throughout the test, except when drawing off the water. Draw off (with pipet or similar instrument) the water that has accumulated on the surface at 10-min intervals during the first 40 min and at 30-min intervals thereafter until cessation of bleeding, recording the time of last observation. To facilitate the collection of bleeding water, tilt the specimen carefully by placing a block approximately 50 mm (2 in.) thick under one side of the container 2 min prior to each time the water is withdrawn. After the water is removed, return the container to a level position without jarring. After each withdrawal, transfer the water to a 100-mL graduated cylinder. Record the accumulated quantity of water after each transfer. When only the total volume of bleeding is desired to be determined, the periodic removal procedure shall be omitted and the entire amount removed in a single operation. If it is desired to determine the mass of the bleeding water and to exclude the material present other than the water, carefully decant the contents of the

cylinder into a metal beaker. Determine the mass and record the mass of the beaker and its contents. Dry the beaker and its contents to constant mass and record the final mass. The difference between the two masses, D , is equal to the mass of the bleeding water. The mass of the sludge shall also be obtained, if desired, by initially determining the tare mass of the beaker.

7. Calculation

7.1 Calculate the volume of bleeding water per unit area of surface, V , as follows:

$$V = V_1/A \quad (1)$$

where:

V_1 = volume of bleeding water measured during the selected time interval, mL, and

A = area of exposed concrete, cm^2 .

The comparative rate of bleeding shall be determined as the test progresses by comparing the volume of bleeding water for each equal time interval.

7.2 Calculate the accumulated bleeding water, expressed as a percentage of the net mixing water contained within the test specimen, as follows:

$$C = (w/W) \times S \quad (2)$$

$$\text{Bleeding, \%} = (D/C) \times 100$$

where:

C = mass of the water in the test specimen, g,

W = total mass of the batch, kg,

w = net mixing water (the total amount of water minus the water absorbed by the aggregates), kg,

S = mass of the sample, g, and

D = mass of the bleeding water, g, or total volume withdrawn from the test specimen in cubic centimeters multiplied by 1 g/cm^3 .

TEST METHOD B—SAMPLE CONSOLIDATED BY VIBRATION

8. Apparatus

8.1 *Vibrating Platform*—A platform shall be provided upon which the filled container shall be mounted. The platform shall be equipped with a suitable device so that intermittent periods of vibration of reproducible duration, frequency, and amplitudes will be imparted to the specimen container as prescribed by Section 8 (see Fig. 1). Suitable vibration will be provided if there is bolted to the platform a 93W ($\frac{1}{8}$ -hp) electric motor, to the shaft of which a small eccentric whose mass is approximately 110 g is attached by means of a setscrew. The eccentric shall be fabricated from cold-rolled stock in accordance with the details and dimensions shown in Fig. 2. The hole through the eccentric is 13.5 mm ($\frac{34}{64}$ in.) or an appropriate size to accommodate the motor shaft. The platform shall be supported on rubber supports resting on a concrete slab. The concrete slab shall be separated from the floor by a layer of cork as shown in Fig. 2.

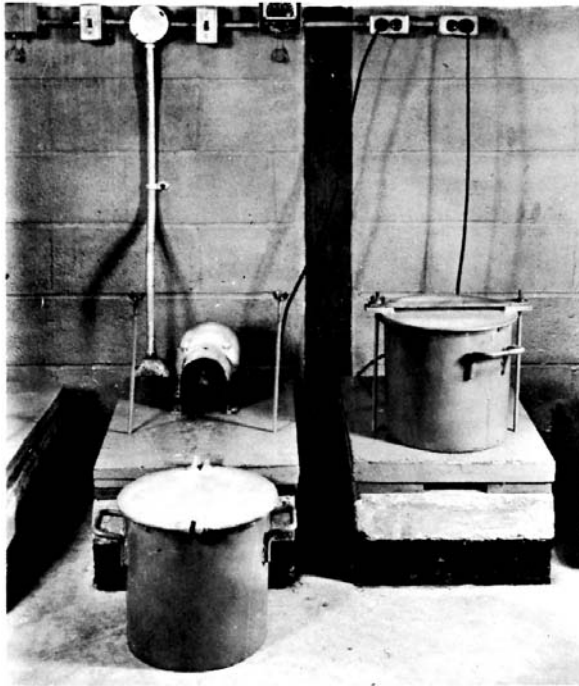

FIG. 1 Vibrating Platform and Timer

8.2 *Timer*—A timing device, by means of which the periods of vibration provided to the platform and specimen in accordance with the provisions of Section 8 is permitted to be regulated.

8.3 *Container*—A steel container 290 mm (11½ in.) in diameter at the top, 280 mm (11 in.) in diameter at the bottom, and 285 mm (11⅛ in.) high shall be provided. A steel container cover shall also be provided. The container and cover shall conform with the details given in Fig. 3.

8.3.1 The remainder of the apparatus is identical with that given for Method A.

9. Vibrating Cycle

9.1 The vibrating cycle shall be as follows: Power on for 3 s, power off 30 s. However, due to the coasting of the motor after the power is turned off, the period of perceptible vibration is approximately 7 s.

10. Test Specimen

10.1 The sample shall be prepared as described for Method A.

10.2 The sample shall be placed in the container to a depth equal to approximately one half the average diameter of the container. The size of the test sample can best be regulated by mass; a sample with a mass of 20 ± 0.5 kg (45 ± 1 lb) usually meets the requirements for the apparatus described herein.

11. Procedure

11.1 *Consolidation of Test Specimen*—Consolidate the sample in the container by means of vibration of only that duration required to effect the desired degree of compaction. Sufficient vibration has been applied as soon as the surface of the concrete has become relatively smooth. Stop the consoli-

dating procedure immediately upon the first appearance of free water segregating from the concrete as indicated by the development of a water sheen on its surface. For some unusually wet or plastic mixtures, no consolidating effort will be needed beyond that supplied by placing the sample in the container and handling the container during the operations of determining the mass and placing it on the platform for test.

11.2 *Intermittent Vibration*—Place the cover on the container and the container on the vibrating platform. Clamp the container and cover down tightly. Note and record the time, and start the motor. Continue intermittent vibration for 1 h.

11.3 *Determination of Bleeding Water*—The intermittent periods of vibrations do not permit the determination of bleeding water at a number of different time intervals. Determine the total volume of bleeding water as described for Method A.

12. Calculation

12.1 Calculate the percentage bleeding water as described for Method A.

13. Report

13.1 Concrete mixture proportions,

13.2 Source and identification of each material used,

13.3 Method used for collection of the bleeding data (A or B),

13.4 The volume of bleeding water per unit area of surface, and the accumulated bleeding water, expressed as a percentage of the net mixing water contained within the test specimen, and

13.5 Elapsed time required for cessation of bleeding.

14. Precision and Bias

14.1 *Precision:*

14.1.1 *Method A*—Data are not available to evaluate the precision of Method A directly. However, there is reason to believe that the precision for Method A is at least as good as that for Method B. The values given for Method B shall be used as maximum precision limits for Method A.

14.1.2 *Method B*—The single operator-day-multibatch standard deviation (1s) has been found to be 0.71 % for a bleeding range from 0 to 10 %, 1.06 % for a bleeding range from 10 to 20 %, and 1.77 % for more than 20 %. Therefore, results of two properly conducted tests by the same operator on the same day on different batches of the same mixture are not expected to differ by more than 2.0 % (d2s) for a bleeding range from 0 to 10 %, 3.0 % for a range from 10 to 20 %, and 5.0 % for more than 20 %. (See Note 1.)

NOTE 1—These numbers represent, respectively, the (1s) and (d2s) limits as described in Practice C 670.

14.2 *Bias*—The test methods have no bias because the values determined can be defined only in terms of the test methods.

15. Keywords

15.1 bleeding; concrete, bleeding of

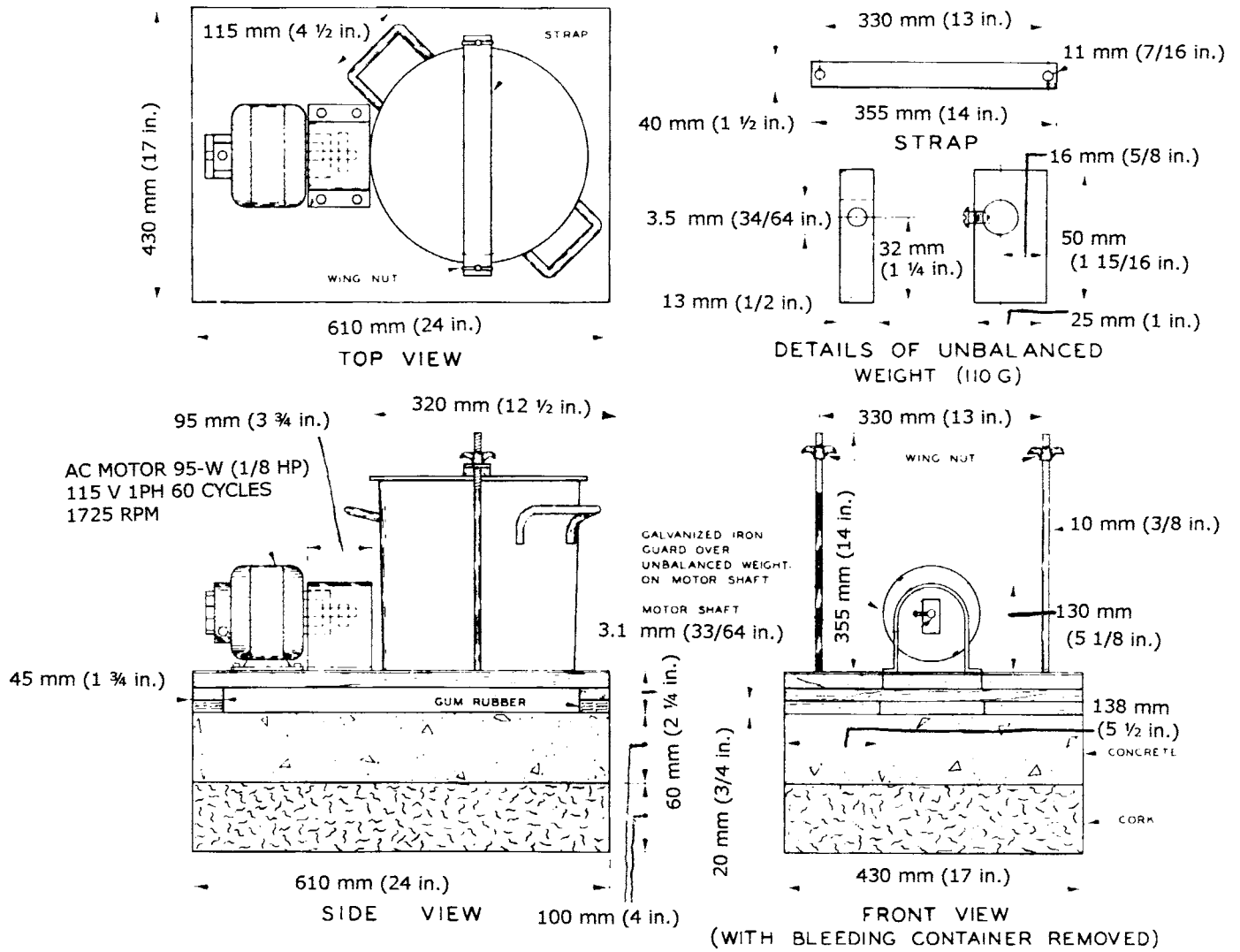

FIG. 2 Detail of Vibrating Platform Apparatus

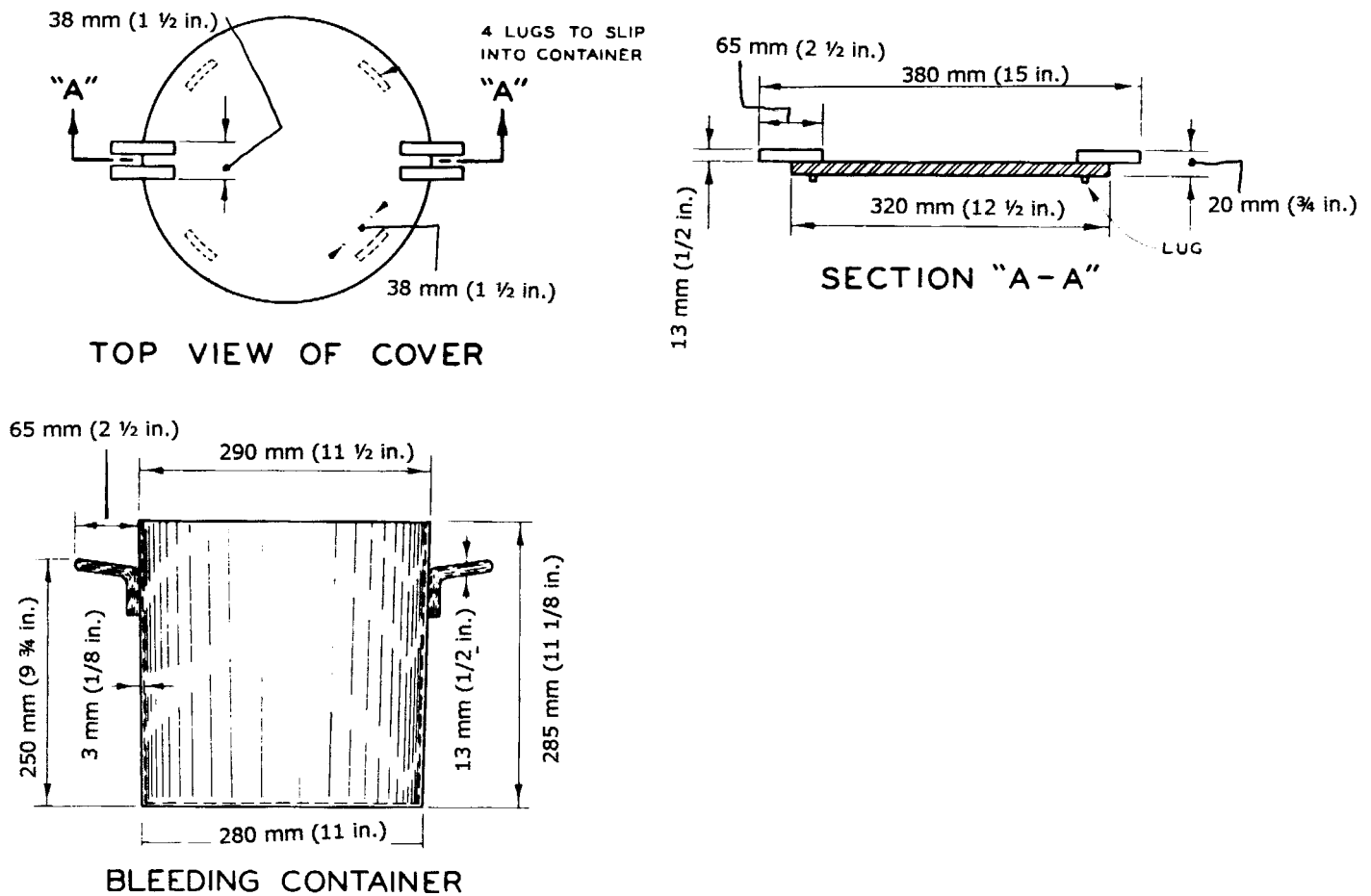

FIG. 3 Container and Cover

SUMMARY OF CHANGES

Committee C09 has identified the location of selected changes to these test methods since the last issue, C 232 - 04, that may impact the use of these test methods. (Approved July 15, 2007)

(I) Revised 4.2.

ASTM International takes no position respecting the validity of any patent rights asserted in connection with any item mentioned in this standard. Users of this standard are expressly advised that determination of the validity of any such patent rights, and the risk of infringement of such rights, are entirely their own responsibility.

This standard is subject to revision at any time by the responsible technical committee and must be reviewed every five years and if not revised, either reapproved or withdrawn. Your comments are invited either for revision of this standard or for additional standards and should be addressed to ASTM International Headquarters. Your comments will receive careful consideration at a meeting of the responsible technical committee, which you may attend. If you feel that your comments have not received a fair hearing you should make your views known to the ASTM Committee on Standards, at the address shown below.

This standard is copyrighted by ASTM International, 100 Barr Harbor Drive, PO Box C700, West Conshohocken, PA 19428-2959, United States. Individual reprints (single or multiple copies) of this standard may be obtained by contacting ASTM at the above address or at 610-832-9585 (phone), 610-832-9555 (fax), or service@astm.org (e-mail); or through the ASTM website (www.astm.org).