



# Standard Test Method for Time of Setting of Hydraulic-Cement Paste by Gillmore Needles<sup>1</sup>

This standard is issued under the fixed designation C 266; the number immediately following the designation indicates the year of original adoption or, in the case of revision, the year of last revision. A number in parentheses indicates the year of last reapproval. A superscript epsilon ( $\epsilon$ ) indicates an editorial change since the last revision or reapproval.

## 1. Scope\*

1.1 This test method covers the determination of the time of setting of hydraulic-cement paste by means of the Gillmore needles.

1.2 The values stated in inch-pound units are to be regarded as standard. The values given in parentheses are mathematical conversions to SI units that are provided for information only and are not considered standard.

1.3 *This standard does not purport to address all of the safety concerns, if any, associated with its use. It is the responsibility of the user of this standard to establish appropriate safety and health practices and determine the applicability of regulatory limitations prior to use.*

**Warning:** Fresh hydraulic cementitious mixtures are caustic and may cause chemical burns to skin and tissue upon prolonged exposure. The use of gloves, protective clothing, and eye protection is recommended. Wash contact area with copious amounts of water after contact. Wash eyes for a minimum of 15 min. Avoid exposure of the body to clothing saturated with the liquid phase of the unhardened material. Remove contaminated clothing immediately after exposure.

1.4 The text of this standard references notes and footnotes which provide explanatory material. These notes and footnotes (excluding those in tables and figures) shall not be considered as requirements of the standard.

## 2. Referenced Documents

### 2.1 ASTM Standards:<sup>2</sup>

- C 151 Test Method for Autoclave Expansion of Hydraulic Cement
- C 183 Practice for Sampling and the Amount of Testing of Hydraulic Cement

<sup>1</sup> This test method is under the jurisdiction of ASTM Committee C01 on Cement and is the direct responsibility of Subcommittee C01.30 on Time of Set  
Current edition approved June 1, 2008. Published July 2008. Originally approved in 1951. Last previous edition approved in 2007 as C 266 – 07.

<sup>2</sup> For referenced ASTM standards, visit the ASTM website, www.astm.org, or contact ASTM Customer Service at service@astm.org. For *Annual Book of ASTM Standards* volume information, refer to the standard's Document Summary page on the ASTM website.

- C 187 Test Method for Normal Consistency of Hydraulic Cement
- C 219 Terminology Relating to Hydraulic Cement
- C 305 Practice for Mechanical Mixing of Hydraulic Cement Pastes and Mortars of Plastic Consistency
- C 511 Specification for Mixing Rooms, Moist Cabinets, Moist Rooms, and Water Storage Tanks Used in the Testing of Hydraulic Cements and Concretes
- C 670 Practice for Preparing Precision and Bias Statements for Test Methods for Construction Materials
- C 1005 Specification for Reference Masses and Devices for Determining Mass and Volume for Use in the Physical Testing of Hydraulic Cements
- D 1193 Specification for Reagent Water

## 3. Terminology

- 3.1 Refer to Terminology C 219 for definitions of terms.

## 4. Summary of Test Method

4.1 Sufficient water is added to the cement that is being tested to produce a paste of normal consistency. A specimen is molded from this paste and is tested for time of setting by means of the Gillmore initial and final needles. The initial time of setting is the time elapsed between initial contact of cement and water and the time when the Gillmore Initial needle does not leave a complete circular impression in the paste surface. The final time of setting is the time elapsed between initial contact of cement and water and the time when the Gillmore Final needle does not leave a complete circular impression in the paste surface.

## 5. Significance and Use

5.1 The purpose of this test method is to establish whether a cement complies with a specification limit on Gillmore time of setting.

## 6. Apparatus

6.1 *Flat Trowel*, having a sharpened straight-edged steel blade 100 to 150 mm in length. The edges when placed on a plane surface shall not depart from straightness by more than 1 mm.

\*A Summary of Changes section appears at the end of this standard.

6.2 *Mixer, Bowl, Paddle, and Scraper*, conforming to the requirements of Practice **C 305**.

6.3 *Glass Graduates*, 200 or 250 mL capacity, conforming to the requirements of Specification **C 1005**.

6.4 *Mass Determining Devices*, conforming to the requirements of Specification **C 1005**. The devices for determining mass shall be evaluated for precision and accuracy at a total load of 1000 g.

6.5 *Plane Non-absorptive Plates*, 100 mm ± 5 mm square, of similar planeness, corrosivity, and absorptivity to that of glass (see Test Method **C 187** Fig. 1, item H).

6.6 *Gillmore Needles*, conforming to the following requirements:

6.6.1 The initial time of setting needle shall have a mass of 0.250 ± 0.001 lb (113.4 ± 0.5 g) and a tip diameter of 0.084 ± 0.002 in. (2.12 ± 0.05 mm).

6.6.2 The final time of setting needle shall have a mass of 1.000 ± 0.001 lb (453.6 ± 0.5 g) and a tip diameter of 0.042 ± 0.002 in. (1.06 ± 0.05 mm).

6.6.3 The needle tips shall be cylindrical for a distance of 0.189 ± 0.020 in. (4.8 ± 0.5 mm). The needle ends shall be plane and at right angles to the axis of the rod and shall be maintained in a clean condition (See **Note 1**).

6.7 Inspect and document Section **6** apparatus for conformance to the requirements of this test method at least every 2 ½ years.

**NOTE 1**—The Gillmore needles should preferably be mounted as shown in **Fig. 1** (b).

## 7. Reagents

7.1 *Mixing Water*—Potable water is satisfactory for routine tests. For all referee and cooperative tests, reagent water conforming to the requirements of Specification **D 1193** for Type III or Type IV grade of reagent water shall be used.

## 8. Sampling

8.1 When the test is part of acceptance testing, sample the cement in accordance with Practice **C 183**.

## 9. Conditioning

9.1 Maintain the temperature of the room, dry materials, paddle, bowl, and plane non-absorptive plates at 23.0 ± 3.0 °C. Maintain the temperature of the mixing water at 23.0 ± 2.0 °C.

9.2 Maintain the relative humidity of the mixing room at not less than 50%.

9.3 The moist cabinet or moist room shall conform to the requirements of Specification **C 511**.

## 10. Procedure

### 10.1 Preparation of Cement Paste:

Obtain the cement paste used for determination of the time of setting from one of the following methods:

10.1.1 Prepare a new batch of paste by mixing 650 g of cement with the percentage of mixing water required for normal consistency (Test Method **C 187**), following the procedure described in Practice **C 305**.

10.1.2 At the option of the tester, use the paste remaining from the batch used for the autoclave expansion specimen (Test Method **C 151**) or from the normal consistency determination (Test Method **C 187**).

10.2 *Molding Test Specimen*—From the cement paste prepared as described in **10.1**, make a pat with a flat top and the sides tapering to a thin edge on a plane non-absorptive plate, conforming to the dimensions and tolerances in **Fig. 1** (a). In molding the pat, flatten the cement paste first on the plate and then form the pat by drawing the trowel from the outer edge toward the center, then flattening the top. After making, place the pat in the moist cabinet or moist room and allow it to remain there except when the determinations of time of setting are being made.

10.3 *Time of Setting Determination*—Determine the time of setting by holding the needle in a vertical position and lightly applying it to the surface of the pat.

10.3.1 Using the Initial Gillmore needle, determine the Gillmore Initial time of setting end point to be the first penetration measurement that does not mark the specimen surface with a complete circular impression. Verify Initial set by obtaining two additional penetration measurements on different areas of the specimen surface. Verification measurements must be obtained within 90 s of the first “initial set” measurement. The elapsed time, in minutes, between the time of contact of cement and mixing water and the end point determined above is the Gillmore initial time of setting.

10.3.2 Using the Final Gillmore needle, determine the Gillmore Final time of setting end point to be the first penetration measurement that does not mark the specimen surface with a complete circular impression. Verify Final set by obtaining two additional penetration measurements on different areas of the specimen surface. Verification measurements must be obtained within 90 s of the first “final set” measurement. The elapsed time, in minutes, between the time of contact of cement and mixing water and the end point determined above is the Gillmore final time of setting.

## 11. Report

11.1 Report the time of setting, to the nearest 5 min, as follows:

Initial Time of Setting, Gillmore	__ min
Final Time of Setting, Gillmore	__ min

## 12. Precision and Bias

12.1 Precision, Gillmore Initial Time of Setting on samples testing between 100 and 341 min. (See **Note 2**)

12.1.1 The single-operator (within laboratory) standard deviation has been found to be 16 min (1s), therefore, results of two properly conducted tests by the same operator on samples of the same cement should not differ from each other by more than 44 min (d2s) (1s and d2s are defined in Practice **C 670**).

12.1.2 The multi-laboratory standard deviation has been found to be 28 min (1s), therefore, results of two properly conducted tests from two different laboratories should not differ from each other by more than 78 min (d2s).

12.2 Precision, Gillmore Final Time of Setting on samples testing between 239 and 561 min (See **Note 2**).

Cement Paste Pat  
 Base diameter  $76 \pm 13$  mm  
 ( $3 \pm 0.5$  in.)  
 Top diameter  $50 \pm 13$  mm  
 ( $2 \pm 0.5$  in.)  
 Center thickness  $13 \pm 3$  mm  
 ( $0.5 \pm 0.125$  in.)

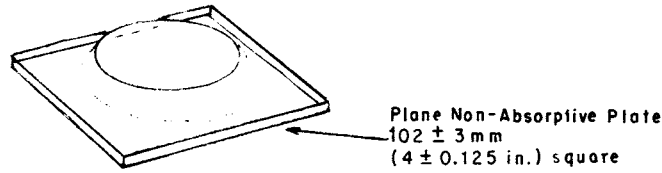

(a) Pat with Top Surface Flattened for Determining Time of Setting by Gillmore Method

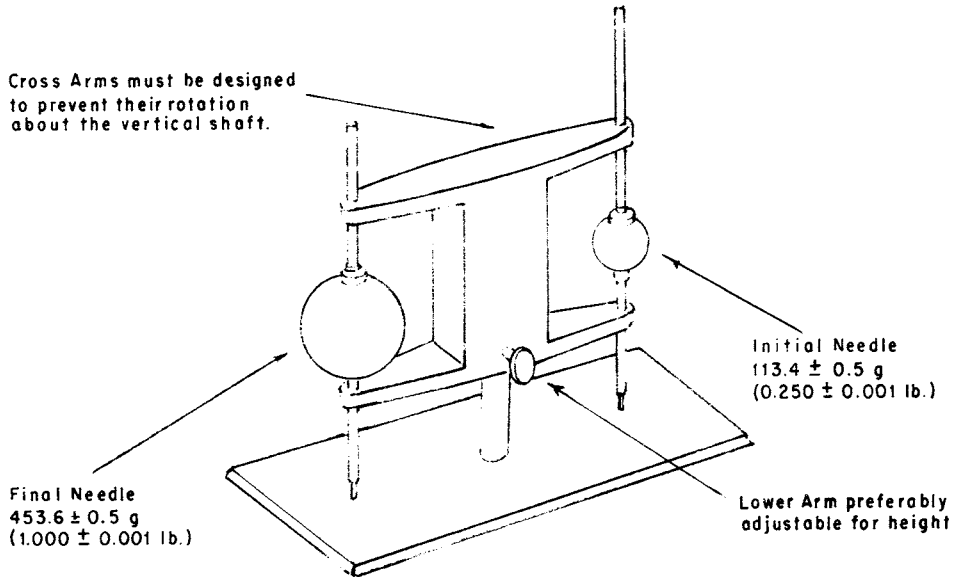

(b) Gillmore Apparatus

Replaceable tips may be made of stock drill rod or wire tempered after shaping and held by suitable chuck or other fastener

Tip Diameter  
 Initial:  $2.12 \pm 0.05$  mm  
 ( $0.084 \pm 0.002$  in.)  
 Final:  $1.06 \pm 0.05$  mm  
 ( $0.042 \pm 0.002$  in.)

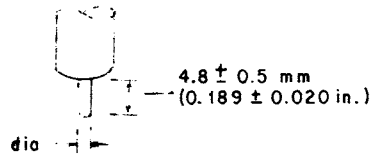

(c) Detail of Gillmore Apparatus Needle Tips  
 FIG. 1 Gillmore Apparatus and Test Specimen

12.2.1 The single-operator (within laboratory) standard deviation has been found to be 22 min (1s), therefore, results of two properly conducted tests by the same operator on samples of the same cement should not differ from each other by more than 62 min (d2s).

12.2.2 The multi-laboratory standard deviation has been found to be 46 min (1s), therefore, results of two properly conducted tests from two different laboratories on samples of the same cement should not differ by more than 129 min (d2s).

### 12.3 Bias

12.3.1 Since an acceptable reference material suitable for determining any bias of this method does not exist, no statement on bias is being made.

NOTE 2—This data is based upon CCRL Portland cement round robin test samples 47 to 138 and CCRL Masonry cement round robin test samples 1 to 46.

## 13. Keywords

13.1 gillmore needles; hydraulic cement paste; time of setting

## SUMMARY OF CHANGES

Committee C01 has identified the location of selected changes to this test method since the last issue, C 266 – 07, that may impact the use of this test method. (Approved June 1, 2008)

(I) Revised 4.1, 6.1, 6.4, and 9.2.

(2) Revised the units statement in 1.2 and reversed the order of units throughout the standard editorially to comply with ASTM Form and Style.

Committee C01 has identified the location of selected changes to this test method since the last issue, C 266 – 04, that may impact the use of this test method. (Approved July 15, 2007)

(I) Added new 6.7.

*ASTM International takes no position respecting the validity of any patent rights asserted in connection with any item mentioned in this standard. Users of this standard are expressly advised that determination of the validity of any such patent rights, and the risk of infringement of such rights, are entirely their own responsibility.*

*This standard is subject to revision at any time by the responsible technical committee and must be reviewed every five years and if not revised, either reapproved or withdrawn. Your comments are invited either for revision of this standard or for additional standards and should be addressed to ASTM International Headquarters. Your comments will receive careful consideration at a meeting of the responsible technical committee, which you may attend. If you feel that your comments have not received a fair hearing you should make your views known to the ASTM Committee on Standards, at the address shown below.*

*This standard is copyrighted by ASTM International, 100 Barr Harbor Drive, PO Box C700, West Conshohocken, PA 19428-2959, United States. Individual reprints (single or multiple copies) of this standard may be obtained by contacting ASTM at the above address or at 610-832-9585 (phone), 610-832-9555 (fax), or service@astm.org (e-mail); or through the ASTM website (www.astm.org).*