



Standard Test Method for Softening Point of Glass¹

This standard is issued under the fixed designation C 338; the number immediately following the designation indicates the year of original adoption or, in the case of revision, the year of last revision. A number in parentheses indicates the year of last reapproval. A superscript epsilon (ϵ) indicates an editorial change since the last revision or reapproval.

This standard has been approved for use by agencies of the Department of Defense.

1. Scope

1.1 This test method covers the determination of the softening point of a glass by determining the temperature at which a round fiber of the glass, nominally 0.65 mm in diameter and 235 mm long with specified tolerances, elongates under its own weight at a rate of 1 mm/min when the upper 100 mm of its length is heated in a specified furnace at the rate of $5 \pm 1^\circ\text{C}/\text{min}$.

1.2 The values stated in SI units are to be regarded as standard. No other units of measurement are included in this standard.

1.3 *This standard does not purport to address all of the safety concerns, if any, associated with its use. It is the responsibility of the user of this standard to establish appropriate safety and health practices and determine the applicability of regulatory limitations prior to use.*

2. Significance and Use

2.1 This test method is useful to determine approximately the temperature below which the glass behaves as a rigid solid in glass-forming operations and for a control test to indicate changes in composition. It has been found useful for specification acceptance and for providing information in research and development work with glass.

3. Apparatus

3.1 The apparatus for determining the softening point of glass shall consist essentially of an electrically heated resistance furnace, a furnace stand, a device for controlling the heating rate of the furnace, equipment for measuring the temperature of the furnace, and equipment for measuring the elongation rate of a fiber of glass suspended in the furnace.

3.1.1 *Furnace*—The furnace shall conform in all essential respects to the requirements shown in Fig. 1.

3.1.2 *Furnace Stand*—A means shall be provided for supporting the furnace so that the fiber hangs below it. This stand must be provided with a leveling device such as three screws. The stand shown in Fig. 1 is convenient when used with either a cathetometer or a telescope and scale.

3.1.3 *Heating Rate Controller*—Suitable controls shall be provided for maintaining the furnace heating rate at $5 \pm 1^\circ\text{C}/\text{min}$.

NOTE 1—A continually adjustable transformer has proved effective for controlling the heating rate.

3.1.4 *Temperature-Measuring Equipment*—The furnace temperature shall be measured with a calibrated Type R or S thermocouple and a calibrated potentiometer capable of measuring the true temperature of the furnace within $\pm 0.2^\circ\text{C}$. The cold junction shall be maintained at 0°C by means of an ice bath. An alternative acceptable means of temperature measurement is the use of a potentiometer to oppose the thermocouple electromotive force. This potentiometer shall be set at a standard setting for the type of glass being measured, and galvanometer deflection shall serve as a means of obtaining relative temperatures, the deflection of the galvanometer having been calibrated. Also acceptable for temperature measurement is a solid-state digital thermometer that is capable of the accuracy specified.

3.1.5 *Fiber-Elongation Measurement Equipment*—The fiber elongation shall be measured by a device capable of measuring the position of the end of the fiber within 0.02 mm throughout the entire elongation period.

NOTE 2—Suitable devices that have proved effective for measuring the elongation are cathetometers, projection magnifiers, and telescope and scale combinations.

3.1.6 *Timer*—A timing device with a least count and accuracy of 1 s shall be used.

4. Preparation of Test Specimens

4.1 The fiber specimen used for the test shall meet the following requirements:

4.1.1 It shall be round.

¹ This test method is under the jurisdiction of ASTM Committee C14 on Glass and Glass Products and is the direct responsibility of Subcommittee C14.04 on Physical and Mechanical Properties.

Current edition approved April 1, 2008. Published June 2008. Originally approved in 1954. Last previous edition approved in 2003 as C 338 – 93 (2003).

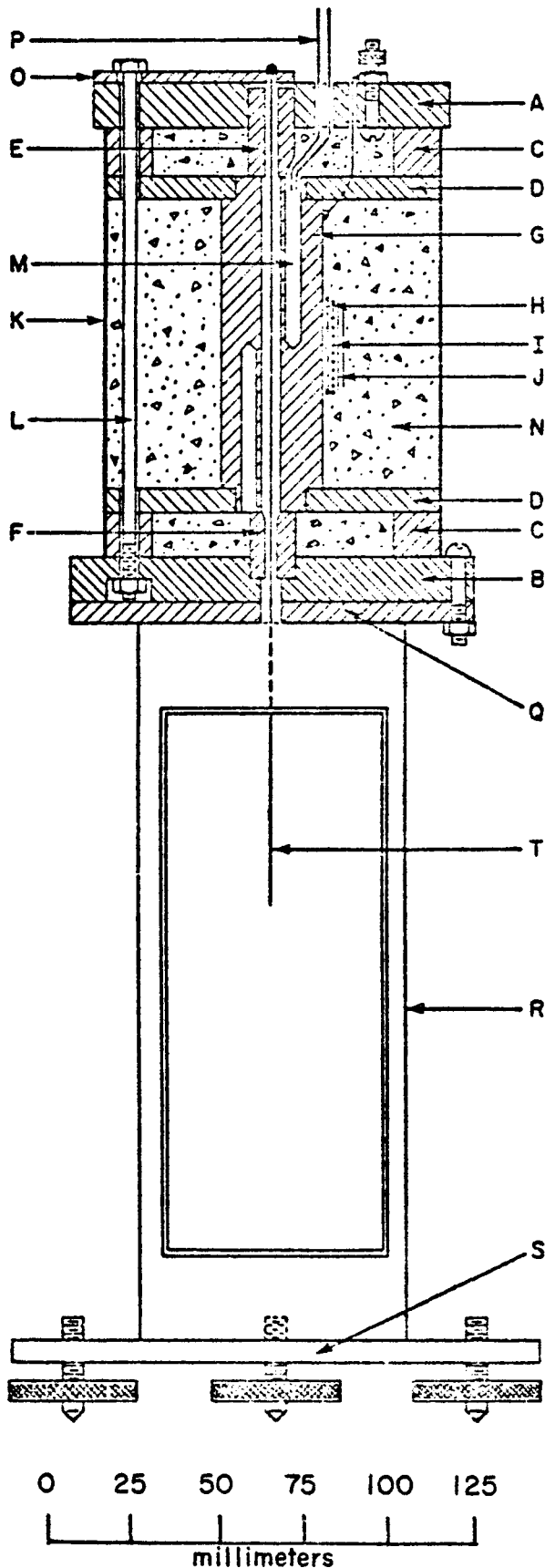

- A—Furnace top, 12.70 mm (½ in.) thick by 101.60 mm (4 in.) in diameter, drilled 12.70 mm (½ in.) diameter at center, with three 5.56 mm (7/32 in.) diameter holes for tie rods spaced 120 deg apart on an 82.55-mm (3¼-in.) circle; also, two small holes suitably placed for thermocouple wires and two binding posts with nearby small holes for passage of heater wires. Material to be Transite II or Marenite or equivalent. One required.
- B—Furnace bottom, 12.70 mm (½ in.) thick by 14.30 mm (4½ in.) in diameter. Drill at center 12.70 mm (½ in.) diameter, 6.35 mm (¼ in.) deep from top; finish through at 5.56 mm (7/32 in.) diameter. Drill three holes for tie rods 120 deg apart on 82.55-mm (3¼-in.) circle, 12.70 mm (½ in.) diameter, 6.35 mm (¼ in.) deep from bottom, finish through at 5.56 mm (7/32 in.) diameter. Drill three 5.56-mm (7/32-in.) holes on 104.77-mm (4⅞ in.) circle. Material to be asbestos cement (Transite or equivalent). One required.
- C—Spacer rings, 12.70 mm (½ in.) thick by 93.66 mm (3⅞ in.) OD by 69.85 mm (2¾ in.) ID, drilled 5.56 mm (7/32 in.) diameter for tie rods. Material to be asbestos cement (Transite or equivalent). Two required.
- D—Webs, 6.35 mm (¼ in.) thick by 93.66 mm (3⅞ in.) diameter drilled 19.05 mm (¾ in.) at center and six 19.05-mm (¾-in.) holes 60 deg apart on 50.8-mm (2-in.) circle; also drilled 5.56 mm (7/32 in.) diameter for tie rods. Material to be asbestos cement (Transite or equivalent). Two required.
- E—Cylinder, 25.4 mm (1 in.) high by 12.7 mm (½ in.) OD by 3.17 mm (⅛ in.) ID, relieved at bottom for thermocouple wires as shown. Material to be asbestos cement (Transite or equivalent). One required.
- F—Cylinder, 19.05 mm (¾ in.) high by 12.7 mm (½ in.) OD by 3.17 mm (⅛ in.) ID with tapered hole at top as shown in Fig. 1. Material to be asbestos cement (Transite or equivalent). One required.
- G—Furnace core, 95.25 mm (3¾ in.) high by 28.58 mm (1⅛ in.) diameter, with 6.35 mm (¼ in.) at each end turned to 19.05 mm (¾ in.) diameter. Entire length drilled at center 5.56 mm (7/32 in.) diameter and symmetrically drilled 3.17 to 5.56 mm (⅞ to 7/32 in.) diameter from each end to depth of 47.62 mm (1⅞ in.) as near to center hole as possible. Material to be stainless steel (such as Inconel, Resisto, or equivalent). One required.
- H—Core wrapping, of mica, double thickness.
- I—Winding, of No. 20 Nichrome V wire, 55 turns, about 12 Ω, wound the whole length of 82.55 mm (3¼ in.) of furnace core.
- J—Alundum cement coating.
- K—Furnace shell, 95.25 mm (3¾ in.) ID by 122.24 mm (4⅞ in.) long, welded. Material to be galvanized sheet steel or preferably stainless sheet steel. One required.
- L—Tie rods, 3.97 mm (5/32 in.) by 152.4 mm (6 in.) threaded at both ends. Material to be steel. Three required.
- M—Double-bore ceramic tubing, 3.17 to 4.76 mm (1/8 to 3/16 in.) diameter. (First insert 3.17 mm (1/8 in.) length to isolate thermocouple from core G.) Material to be porcelain. One required.
- N—Insulation, consisting of diatomaceous earth (Sil-O-Cel or equivalent).
- O—Fiber support, 57.15 mm (2¼ in.) by 12.7 mm (½ in.) by 3.17 mm (1/8 in.) with 0.79-mm (1/32-in.) hole on center line 6.35 mm (¼ in.) from one end and 6.35-mm (¼-in.) hole at other end, the holes to be 41.27 mm (1⅝ in.) apart on centers. Material to be brass. One required.
- P—Thermocouple leads.
- Q—Plate, 6.35 mm (¼ in.) by 114.3 mm (4½ in.) diameter, securely fastened (for example, welded) to lower chamber, with three holes to match edge holes of furnace bottom. Drilled at center 5.56 mm (7/32 in.) diameter. Material to be steel. One required.
- R—Lower chamber consisting of cylinder 203.20 mm (8 in.) long and 76.20 mm (3 in.) diameter, carrying a flat glass window 63.5 mm (2½ in.) by 152.4 mm (6 in.). Material to be galvanized sheet steel or preferably stainless sheet steel. One required.
- S—Bottom plate, 6.35 mm (¼ in.) by 152.4 mm (6 in.) diameter securely fastened (for example, welded) to lower chamber and carrying three levelling screws on 133.35-mm (5¼-in.) circle. Material to be steel. One required.
- T—Glass samples, 235 ± 1.0 mm in length, exclusive of bead at top end, and 0.65 ± .10 mm in diameter, uniform to ± 0.01 mm.

NOTE—Equivalent materials may be employed, where available.

FIG. 1 Details of Softening Point Furnace



4.1.2 It shall be smooth and shall contain no void spots or foreign matter.

4.1.3 Its average diameter shall be 0.65 ± 0.10 mm and the maximum diameter shall not exceed the minimum diameter by more than 0.02 mm over the entire length of the fiber.

4.1.4 It shall be 235 ± 1 mm in length, not including the top bead. Test fibers conforming to these requirements may be drawn by attaching a clean sample of the glass under test between two infusible rods (such as platinum-group alloys, porcelain, or fused silica) and flame-working the sample until the glass is sufficiently fluid to be drawn into a fiber. If the sample is in long stick cane form, it may be flame-worked directly without attaching it to a handle. Acceptable fiber sections may then be broken from the fiber and a bead formed on one end of the fiber section by fusing in the flame. The opposite end shall then be broken to the specified length and the tip may be fire-polished if desired.

5. Calibration with Standard Glass

5.1 Calibration of the apparatus shall be done by measuring in duplicate the softening point of appropriate calibrating or standard glass(es),² the softening points of which are near to that of the test glass. Compute the difference between the average measured softening point and the certified softening point for the standard glass(es), and the average of these differences. If the average difference is greater than 1°C from the certified values, add or subtract this difference as a correction factor to the measured softening points of the unknown glasses.

6. Procedure

6.1 To equalize the heat distribution of the furnace, heat the fiber furnace to about 30°C above the expected softening point of the glass under test. Then cool the furnace to about 20°C below the expected softening point and determine the settings on the heating rate controller that will give a heating rate of 5 ± 1 °C/min.

² Calibrating glasses known as standard reference materials (SRMs) are available from the National Institute of Standards and Technology (NIST). See Table 1 of NIST Special Publication 260, SRM Program, NIST, Gaithersburg, MD 20899. Glass SRMs available and their certified values are listed in the back of Vol 15.02 1999 *Annual Book of ASTM Standards*.

The sole source of supply of the SRMs known to the committee at this time is National Institute of Standards and Technology (NIST). If you are aware of alternative suppliers, please provide this information to ASTM International Headquarters. Your comments will receive careful consideration at a meeting of the responsible technical committee,¹ which you may attend.

ASTM International takes no position respecting the validity of any patent rights asserted in connection with any item mentioned in this standard. Users of this standard are expressly advised that determination of the validity of any such patent rights, and the risk of infringement of such rights, are entirely their own responsibility.

This standard is subject to revision at any time by the responsible technical committee and must be reviewed every five years and if not revised, either reapproved or withdrawn. Your comments are invited either for revision of this standard or for additional standards and should be addressed to ASTM International Headquarters. Your comments will receive careful consideration at a meeting of the responsible technical committee, which you may attend. If you feel that your comments have not received a fair hearing you should make your views known to the ASTM Committee on Standards, at the address shown below.

This standard is copyrighted by ASTM International, 100 Barr Harbor Drive, PO Box C700, West Conshohocken, PA 19428-2959, United States. Individual reprints (single or multiple copies) of this standard may be obtained by contacting ASTM at the above address or at 610-832-9585 (phone), 610-832-9555 (fax), or service@astm.org (e-mail); or through the ASTM website (www.astm.org).

6.2 Again, cool and hold the furnace about 20°C below the expected softening point and insert the fiber in the furnace by placing the bead end in the furnace sample holder. Check the fiber to be certain it is hanging free in the center of the furnace and relevel the furnace if necessary. Standardize the potentiometer and adjust the elongation measuring equipment.

6.3 Set the furnace control for a heating rate of 5 ± 1 °C/min. Observe the fiber as the furnace heats, and when it begins to elongate at the rate of approximately 0.1 mm/min, start recording the fiber length to within 0.02 mm. Take a length reading at the end of each minute and take the temperature of the furnace at each ½-min point. Continue to read and record the length and the temperature until the elongation becomes 1.2 mm or greater in a 1-min period. When the elongation exceeds 1.2 mm in a 1-min interval, remove the fiber and cool the furnace for a duplicate run. An alternative acceptable method is to read the length at 1- and ½-min points, and the temperature at the ¼- and ¾-min points, continuing to read and record length and temperature until the elongation becomes 0.6 mm or greater in a ½-min period.

7. Calculation

7.1 Determine the temperature at which the elongation is 1 mm/min. This may be done by any reliable method, one of which is as follows. Plot the data on semi-log paper, the potentiometer or temperature readings on the uniform scale, and the difference between length readings per unit time on the log scale. The point at which a straight line drawn through the points crosses the 1.0-mm/min line shall be taken as the indicated softening point. Make the calibration corrections as specified in Section 5 if necessary.

8. Report

8.1 Report the following information:

- 8.1.1 Designation of the material, name of the manufacturer, and identifying production data, when known,
- 8.1.2 Identification of the softening point apparatus used,
- 8.1.3 Average softening point temperature, and
- 8.1.4 Date of test and name of operator.

9. Precision and Bias

9.1 This test method in general will yield softening points within 1°C on duplicate checks. The accuracy of results should be checked by determining the softening point of appropriate standard glasses² as indicated in the calibration procedure (Section 5).