



Standard Test Methods for Density of Granular Loose Fill Insulations¹

This standard is issued under the fixed designation C 520; the number immediately following the designation indicates the year of original adoption or, in the case of revision, the year of last revision. A number in parentheses indicates the year of last reapproval. A superscript epsilon (ϵ) indicates an editorial change since the last revision or reapproval.

This standard has been approved for use by agencies of the Department of Defense.

1. Scope

1.1 These test methods are applicable to granular loose fill insulation materials such as vermiculite and perlite. They are used for other insulation materials with similar flow and settling properties.

1.2 *Method A* shall be used to determine bulk density.

1.3 *Method B* shall be used to determine design density and, with *Method A*, is used to calculate percent loss of volume due to settling.

1.4 *This standard does not purport to address all of the safety concerns, if any, associated with its use. It is the responsibility of the user of this standard to establish appropriate safety and health practices and determine the applicability of regulatory limitations prior to use.*

2. Referenced Documents

2.1 *ASTM Standards*:²

C 168 Terminology Relating to Thermal Insulation

C 390 Practice for Sampling and Acceptance of Preformed Thermal Insulation Lots

3. Terminology

3.1 The definitions of terms used in this method shall be in accordance with Terminology C 168.

3.2 *Definitions of Terms Specific to This Standard*:

3.2.1 *bulk density*—the density of the granular material is determined in accordance with *Method A*. No conditioning is required unless specified. The density is determined for the material as received. The voids incorporated during the placement procedure are included.

3.2.2 *design density*—the density of the conditioned granular material, determined in accordance with *Method B*. The normal voids incorporated during the placement and subsequent procedures are included.

3.2.3 *percent volume loss*—the loss in volume between the as received bulk density and the design density determined by induced settling procedures or specified conditioning, or both, expressed as a percent.

4. Significance and Use

4.1 *Method A* will be used primarily as a manufacturing quality control and field test method without the need for conditioning. For more accurate research purposes, conditioning shall be specified.

4.2 *Method B* will be used, when specified, to determine the density at which insulation properties such as thermal resistance and placement coverage are to be determined.

5. Apparatus

5.1 *Bulk Density Container*—A lightweight rigid box with interior length, width, and depth of 12.0 ± 0.1 in. (3.05 ± 3 mm). Scales or balances with an accuracy of at least 1 % of the specimen weight shall be used.

5.2 *Design Density Sample Container*—The specimen container shall be made of nominal $\frac{1}{2}$ in. thick construction grade plywood and two 48-in. (1220 mm) long sections of, nominal 2 by 8-in. lumber. The 2 by 8 sections of wood and plywood shall be used to provide inside container dimensions of 14.5 ± 0.1 in. (368 ± 3 mm) by 48 ± 0.1 in. (1.22 ± 0.003 m) by 7.5 ± 0.1 in. (191 ± 3 mm). The inside dimensions of the specimen container shall be used to calculate the volume of the container.

5.3 *Screed*—A suitable piece of wood, metal, or plastic at least 20 in. (508 mm) long with a thin straight edge suitable for leveling the loose, granular material.

5.4 *Tapping Hammer and Frame*—This shall include a standard $7\frac{1}{2}$ -lb (3.4 kg) sledge hammer. The total length of the handle shall be approximately 34 in. (864 mm). A $\frac{1}{4}$ -in. (6-mm) hole is drilled through the handle to provide a pivot point $32\frac{1}{8} \pm \frac{1}{8}$ in. (816 ± 3 mm) from the center line of

¹ These test methods are under the jurisdiction of ASTM Committee C16 on Thermal Insulation and are the direct responsibility of Subcommittee C16.32 on Mechanical Properties.

Current edition approved April 1, 2004. Published May 2004. Originally approved in 1963. Last previous edition approved in 1998 as C 520 – 98.

² For referenced ASTM standards, visit the ASTM website, www.astm.org, or contact ASTM Customer Service at service@astm.org. For *Annual Book of ASTM Standards* volume information, refer to the standard's Document Summary page on the ASTM website.

the head of the hammer. The tapping hammer shall be mounted in a moveable frame as shown in Fig. 1.

5.5 *Blowing Machine, Optional*—A blowing machine, if used, shall be typical of the type of blowing machine recommended by the insulation manufacturer and shall be equipped with 100 ft. (30 m) of the type and diameter of blower hose recommended by the insulation manufacturer for field installation.

6. Sampling

6.1 For the purposes of standard tests, sampling shall be in accordance with Criteria C390.

7. Conditioning

7.1 When specified as a requirement of testing, condition specimens for at least 24 h at 50 ± 2 % relative humidity and 73 ± 2°F (23 ± 1.1°C), and test under the specified conditions.

8. Procedure

8.1 *Method A:*

8.1.1 Remove approximately one cubic foot of insulation to be tested from the shipping container in such a way to provide a representative distribution of particle size and weight.

8.1.2 Fill the bulk density specimen container described in 5.1 to overflowing with a shovel or scoop, discharging the insulation from a height not to exceed 2 in. (51 mm) above the top of the container. Take care to prevent, so far as possible, segregation of the particle sizes of which the specimen is composed. Level off the surface of the insulation in such a way that any slight projections of the larger pieces of the coarse

insulation shall approximately balance the larger voids in the surface below the top of the container. Take care not to compact the specimen.

8.1.3 Determine the net weight of the insulation by subtracting the weight of the empty container from the weight of the full container.

8.1.4 Using fresh material, repeat the test for a total of three times.

8.1.5 *Calculation*—Calculate bulk density as follows:

$$\text{Bulk density (B)} = \frac{W}{V} \tag{1}$$

where:

W = net weight, lb (kg), and

V = volume of container, ft³(m³).

8.2 *Method B:*

8.2.1 Weigh test bags of insulation.

8.2.2 Place the specimen container on a flat surface. Pour the material into the container from a height of not less than 6 in. (152 mm) nor more than 24 in. (610 mm) above the top of the container in a natural motion and speed normal to that used in the field. Use the screed to level off the material to the top of the container, being careful not to compress or compact the insulation.

8.2.3 Place the specimen frame and tapping hammer against the side of the specimen container, and draw the face of the hammer back 12 ± ½ in. from the side of the container. Allow the hammer to pivot freely into the side of the specimen one time from each side (repositioning the frame each time).

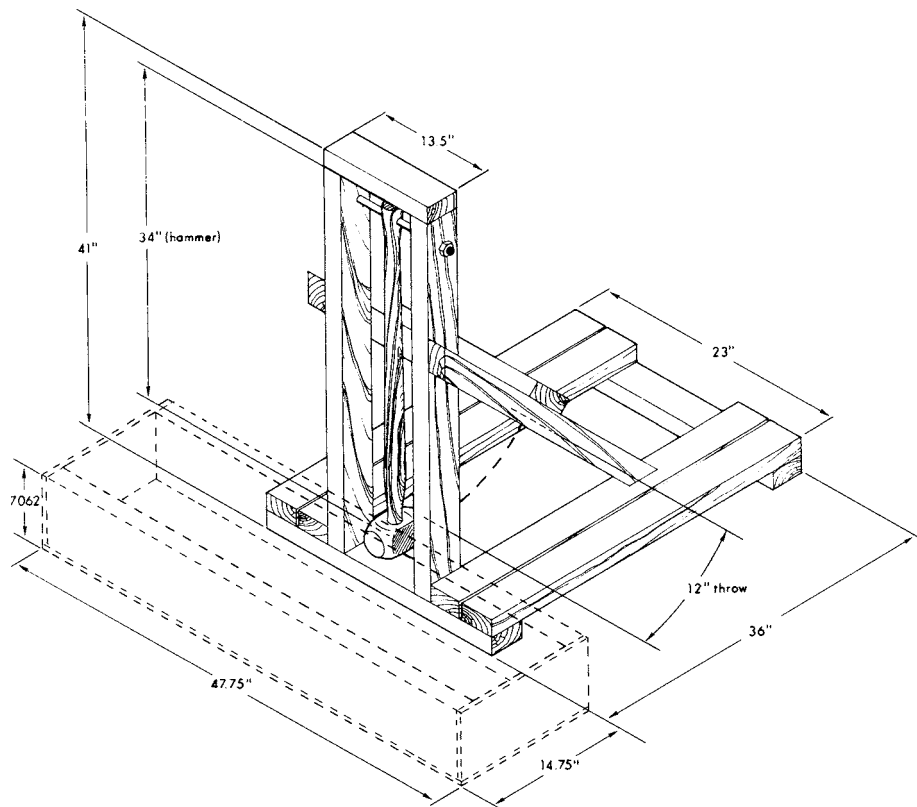

FIG. 1 Tapping Hammer and Frame

8.2.4 Refill the specimen container by adding additional insulation and leveling with the top of the container.

8.2.5 Determine the net weight of the insulation by subtracting the weight of the empty container from the weight of the full container.

8.2.6 Using fresh material, repeat the test for a minimum of three measurements.

8.2.7 *Calculations:*

8.2.7.1 Calculate the design density as follows:

$$\text{Design density (D)} = \frac{W}{M} \quad (2)$$

where:

W = final net weight, lb (kg), and

V = volume of container, ft³(m³).

8.2.7.2 Calculate the volume loss as follows:

$$\text{Volume loss (\%)} = \frac{D - B}{B} \times 100 \quad (3)$$

9. Report

9.1 Report the following information:

9.1.1 Report the density in pounds per cubic foot (kilograms per cubic meter) for each test and the average of the three or more tests for each method.

9.1.2 If required, report the percent volume loss on placement for each specimen and the average of the three or more tests.

10. Precision and Bias

10.1 Granular loose fill insulations, as a class, generally require care in handling during testing due to friability, varying particle size, and a tendency to pack, settle, or segregate as a result of rough handling or vibration.

10.2 The precision of Test Method A with regard to a single unit of product, can be stated only in terms of a single operator, single measurement, and single specimen. At the 95 % confidence limit, the standard deviation is ± 0.25 lb/ft³, for vermiculite and ± 0.30 lb/ft³ for perlite.

10.3 The precision of Test Method B is expressed as the precision of a single operator, multiple specimens, and a single measurement of design density. At the 95 % confidence limit, the standard deviation is ± 0.12 lb/ft³ for vermiculite and ± 0.20 lb/ft³ for perlite.

10.4 *Bias*—no information is presented on the bias of the procedures in Test Method C 520 for measuring density of granular loose fill insulations because no material having an accepted reference value is available.

11. Keywords

11.1 bulk density; density; design density; granular loose fill; insulation; perlite; thermal insulation; vermiculite; volume loss

ASTM International takes no position respecting the validity of any patent rights asserted in connection with any item mentioned in this standard. Users of this standard are expressly advised that determination of the validity of any such patent rights, and the risk of infringement of such rights, are entirely their own responsibility.

This standard is subject to revision at any time by the responsible technical committee and must be reviewed every five years and if not revised, either reapproved or withdrawn. Your comments are invited either for revision of this standard or for additional standards and should be addressed to ASTM International Headquarters. Your comments will receive careful consideration at a meeting of the responsible technical committee, which you may attend. If you feel that your comments have not received a fair hearing you should make your views known to the ASTM Committee on Standards, at the address shown below.

This standard is copyrighted by ASTM International, 100 Barr Harbor Drive, PO Box C700, West Conshohocken, PA 19428-2959, United States. Individual reprints (single or multiple copies) of this standard may be obtained by contacting ASTM at the above address or at 610-832-9585 (phone), 610-832-9555 (fax), or service@astm.org (e-mail); or through the ASTM website (www.astm.org).