



## Standard Practice for Capping Cylindrical Concrete Specimens<sup>1</sup>

This standard is issued under the fixed designation C 617; the number immediately following the designation indicates the year of original adoption or, in the case of revision, the year of last revision. A number in parentheses indicates the year of last reapproval. A superscript epsilon ( $\epsilon$ ) indicates an editorial change since the last revision or reapproval.

*This standard has been approved for use by agencies of the Department of Defense.*

### 1. Scope

1.1 This practice covers apparatus, materials, and procedures for capping freshly molded concrete cylinders with neat cement and hardened cylinders and drilled concrete cores with high-strength gypsum plaster or sulfur mortar.

1.2 The values stated in inch-pound units are to be regarded as the standard. The SI equivalents of inch-pound units may be approximate.

1.3 *This standard does not purport to address all of the safety concerns, if any, associated with its use. It is the responsibility of the user of this standard to establish appropriate safety and health practices and determine the applicability of regulatory limitations prior to use. For specific precaution statements see 4.3 and 6.2.3.1.*

### 2. Referenced Documents

#### 2.1 ASTM Standards:<sup>2</sup>

C 109/C 109M Test Method for Compressive Strength of Hydraulic Cement Mortars (Using 2-in. or 50-mm Cube Specimens)

C 150 Specification for Portland Cement

C 472 Test Methods for Physical Testing of Gypsum, Gypsum Plasters and Gypsum Concrete

C 595M Specification for Blended Hydraulic Cements

C 1231 Practice for Use of Unbonded Caps in Determination of Compressive Strength of Hardened Concrete Cylinders

#### 2.2 ANSI Standard:

B46.1 Standard for Surface Texture (Surface, Roughness, Waviness and Lay)<sup>3</sup>

### 3. Significance and Use

3.1 This practice describes procedures for providing plane surfaces on the ends of freshly molded concrete cylinders, hardened cylinders, or drilled concrete cores when the end surfaces do not conform with the planeness and perpendicularity requirements of applicable standards. Practice C 1231 describes alternative procedures using unbonded caps or pad caps.

### 4. Capping Equipment

4.1 *Capping Plates*—Neat cement caps and high-strength gypsum-plaster caps shall be formed against a glass plate at least  $\frac{1}{4}$  in. (6 mm) thick, a machined metal plate at least 0.45 in. (11 mm) thick, or a polished plate of granite or diabase at least 3 in. (76 mm) thick. Sulfur mortar caps shall be formed against similar metal or stone plates except that the recessed area which receives molten sulfur shall not be deeper than  $\frac{1}{2}$  in. (12 mm). In all cases, plates shall be at least 1 in. (25 mm) greater in diameter than the test specimen and the working surfaces shall not depart from a plane by more than 0.002 in. (0.05 mm) in 6 in. (152 mm). The surface roughness of newly finished metal plates shall not exceed that set forth in Table 4 of American National Standard B46.1, or 125  $\mu\text{in.}$  (3.2  $\mu\text{m}$ ) for any type of surface and direction of lay. The surface, when new, shall be free of gouges, grooves, or indentations beyond those caused by the finishing operation. Metal plates that have been in use shall be free of gouges, grooves, and indentations greater than 0.010 in. (0.25 mm) deep or greater than 0.05 in.<sup>2</sup>(32 mm<sup>2</sup>) in surface area.

NOTE 1—A Rockwell hardness of 48 HRC is suggested for capping plates of devices used to form sulfur mortar caps.

4.2 *Alignment Devices*—Suitable alignment devices, such as guide bars or bull's-eye levels, shall be used in conjunction with capping plates to ensure that no single cap will depart from perpendicularity to the axis of a cylindrical specimen by more than  $0.5^\circ$  (approximately equivalent to  $\frac{1}{8}$  in. in 12 in. (3.2 mm in 305 mm)). The same requirement is applicable to the relationship between the axis of the alignment device and the surface of a capping plate when guide bars are used. In addition, the location of each bar with respect to its plate must

<sup>1</sup> This practice is under the jurisdiction of ASTM Committee C09 on Concrete and Concrete Aggregates and is the direct responsibility of Subcommittee C09.61 on Testing for Strength.

Current edition approved August 10, 1998. Published December 1998. Originally approved in 1968. Last previous edition approved in 1998 as C 617 – 98 (2003).

<sup>2</sup> For referenced ASTM standards, visit the ASTM website, [www.astm.org](http://www.astm.org), or contact ASTM Customer Service at [service@astm.org](mailto:service@astm.org). For *Annual Book of ASTM Standards* volume information, refer to the standard's Document Summary page on the ASTM website.

<sup>3</sup> Available from American Society of Mechanical Engineers, 345 E. 47th Street, New York, NY 10017.

be such that no cap will be off-centered on a test specimen by more than  $\frac{1}{16}$  in. (2 mm).

4.3 *Melting Pots for Sulfur Mortars*—Pots used for melting sulfur mortars shall be equipped with automatic temperature controls and shall be made of metal or lined with a material that is nonreactive with molten sulfur.

4.3.1 **Caution:** Melting pots equipped with peripheral heating will ensure against accidents during reheating of cooled sulfur mixture that have a crusted-over surface. When using melting pots not so equipped, a build-up of pressure under the hardened surface crust on subsequent reheating may be avoided by use of a metal rod that contacts the bottom of the pot and projects above the surface of the fluid sulfur mix as it cools. The rod should be of sufficient size to conduct enough heat to the top on reheating to melt a ring around the rod first and thus avoid the development of pressure. A large metal ladle can be substituted for the rod.

4.3.1.1 Use sulfur melting pots in a hood to exhaust the fumes to outdoors. Heating over an open flame is dangerous because the flash point of sulfur is approximately 440°F (227°C) and the mixture can ignite due to overheating. Should the mixture start to burn, covering will snuff out the flame. The pot should be recharged with fresh material after the flame has been extinguished.

## 5. Capping Materials

5.1 The strength of the capping material and the thickness of the caps shall conform to the requirements of Table 1.

5.1.1 If sulfur mortar, high strength gypsum plaster and other materials except neat cement paste are to be used to test concrete with a strength greater than 7000 psi (50 MPa), the manufacturer or the user of the material must provide documentation:

5.1.1.1 That the average strength of 15 cylinders capped with the material is not less than 98 percent of the average strength of 15 companion cylinders capped with neat cement paste or 15 cylinders ground plane to within 0.002 in. (0.05 mm).

5.1.1.2 That the standard deviation of the strengths of the capped cylinders is not greater than 1.57 times that of the standard deviation of the reference cylinders.

5.1.1.3 That the cap thickness requirements were met in the qualification tests, and

5.1.1.4 Of the hardening time of the caps used in the qualification tests.

5.1.2 Additionally, the qualification test report must include the compressive strength of 2 in. cubes of the material qualified and of neat cement paste cubes, if used. Capping materials conforming to these requirements is permitted to be used for cylinders with strengths up to 20 percent greater than the concrete tested in these qualification tests. The manufacturer must requalify lots of material manufactured on an annual basis or whenever there is a change in the formulation or the raw materials. The user of the material must retain a copy of the qualification results, and the dates of manufacture of material qualified and of the material currently being used. See Table 2.

5.1.3 The compressive strength of capping materials shall be determined by testing 2 in. cubes following the procedure described in Test Method C 109. Except for sulfur mortars, molding procedures shall be as in Test Method C 109 unless other procedures are required to eliminate large entrapped air voids. See Test Methods C 472 for alternative compaction procedures. Cure cubes in the same environment for the same length of time as the material used to cap specimens.

5.1.4 The strength of the capping material shall be determined on receipt of a new lot and at intervals not exceeding three months. If a given lot of the capping material fails to conform to the strength requirements, it shall not be used, and strength tests of the replacement material shall be made weekly until four consecutive determinations conform to specification requirements.

### 5.2 Neat Hydraulic Cement Paste:

5.2.1 Make qualification tests of the neat hydraulic cement paste prior to use for capping to establish the effects of water-cement ratio and age on compressive strength of 2 in. (50 mm) cubes.

NOTE 2—The cements used generally conform to Specification C 150 Types I, II or III; however, Specification C 595 blended cements, calcium aluminate or other hydraulic cements producing acceptable strength may be used.

5.2.2 Mix the neat cement paste to the desired consistency at a water-cement ratio equal to or less than that required to produce the required strength, generally 2 to 4 h before the paste is to be used (Note 3). Remix as necessary to maintain acceptable consistency (Note 4). Some retempering of the paste is acceptable if the required water-cement ratio is not exceeded. Optimum consistency is generally produced at water-cement ratios of 0.32 to 0.36 by mass for Type I and Type II cements and 0.35 to 0.39 by mass for Type III cements.

NOTE 3—Freshly mixed pastes tend to bleed, shrink, and make unacceptable caps. The 2 to 4 h period is generally appropriate for portland cements.

NOTE 4—The required consistency of the paste is determined by the appearance of the cap when it is stripped. Fluid paste results in streaks in the cap. Stiff paste results in thick caps.

### 5.3 High-Strength Gypsum Cement Paste:

5.3.1 No fillers or extenders may be added to neat high-strength gypsum cement paste subsequent to the manufacture of the cement. (Note 5) Qualification tests shall be made to determine the effects of water-cement ratio and age on compressive strength of 2 in. (50 mm) cubes. Retarders may be used to extend working time, but their effects on required water-cement ratio and strength must be determined. (Note 6)

**TABLE 1 Compressive Strength and Maximum Thickness of Capping Materials**

Cylinder Compressive Strength psi (MPa)	Minimum Strength of Capping Material	Maximum Average Thickness of Cap	Maximum Thickness Any Part of Cap
500 to 7000 psi (3.5 to 50 MPa)	5000 psi (35 MPa) or cylinder strength whichever is greater	$\frac{1}{4}$ in. (6 mm)	$\frac{5}{16}$ in. (8 mm)
greater than 7000 psi (50 MPa)	Compressive strength not less than cylinder strength, except as provided in 5.1.1	$\frac{1}{8}$ in. (3 mm)	$\frac{3}{16}$ in. (5 mm)

**TABLE 2 Sample Report of Qualification of a Capping Material**

NOTE—Manufacturer: Testing Supplies Co.  
 Capping Material: Super Strong AAA-Sulfur mortar  
 Lot: 12a45      Date Tested: 11/3/98  
 Signed by: \_\_\_\_\_ (testing agency and responsible official)

Item	Capping Material	Control Cylinders	Ratio	Criteria	Pass/Fail
Concrete Cylinder Test Data					
Type of capping material	Sulfur	Ground			
Average Concrete Strength, psi [MPa]	11 061 (76.2)	11 008 (75.9)	1.005	>0.98 X <sub>c</sub>	Pass
Standard Deviation, psi [MPa]	376 (2.59)	250 (1.72)	1.504	≤1.57 C	Pass
Number of cylinders tested	15	15			
Cap age when cylinders tested	7 days	na			
Capping Material Test Data					
Average cap thickness, in. [mm]	0.11 (2.8)	na			
Compressive strength of 2 in. [50 mm] cubes, psi (MPa)	12 195 (91)				
Cube age when tested.	7 days				
Maximum concrete strength qualified, psi (MPa)				1.2 Av. Str = 13 273 (91.5) <sup>A</sup>	

<sup>A</sup> Nominally a specified strength of 11 000 psi (75 MPa) and perhaps somewhat higher.

NOTE 5—Low-strength molding plaster, plaster of paris, or mixtures of plaster of paris and portland cement are unsuitable for capping.

NOTE 6—The water-gypsum cement ratio should be between 0.26 and 0.30. Use of low water-cement ratios and vigorous mixing will usually permit development of 5000 psi (35 MPa) at ages of 1 or 2 h. Higher water-gypsum cement ratios extend working time, but reduce strength.

5.3.2 Mix the neat gypsum cement paste at the desired water-cement ratio and use it promptly since it sets rapidly.

**5.4 Sulfur Mortar:**

5.4.1 Proprietary or laboratory prepared sulfur mortars are permitted if allowed to harden a minimum of 2 h before testing concrete with strength less than 5000 psi (35 MPa). For concrete strengths of 5000 psi or greater, sulfur mortar caps must be allowed to harden at least 16 h before testing, unless a shorter time has been shown to be suitable as specified in 5.1.1.

**5.4.2 Determination of Compressive Strength**—Prepare test specimens using a cube mold and base plate conforming to the requirements of Test Method C 109 and a metal cover plate conforming in principle to the design shown in Fig. 1 (Note 7). Bring the various parts of the apparatus to a temperature of 68 to 86°F (20 to 30°C), lightly coat the surfaces that will be in contact with the sulfur mortar with mineral oil, and assemble near the melting pot. Bring the temperature of the molten-sulfur mortar in the pot within a range of 265 to 290°F (129 to 143°C), stir thoroughly, and begin casting cubes. Using a ladle, or other suitable pouring device, quickly fill each of the three compartments until the molten material reaches the top of the filling hole. Allow sufficient time for maximum shrinkage, due to cooling, and solidification to occur (approximately 15 min) and refill each hole with molten material (Note 8). After

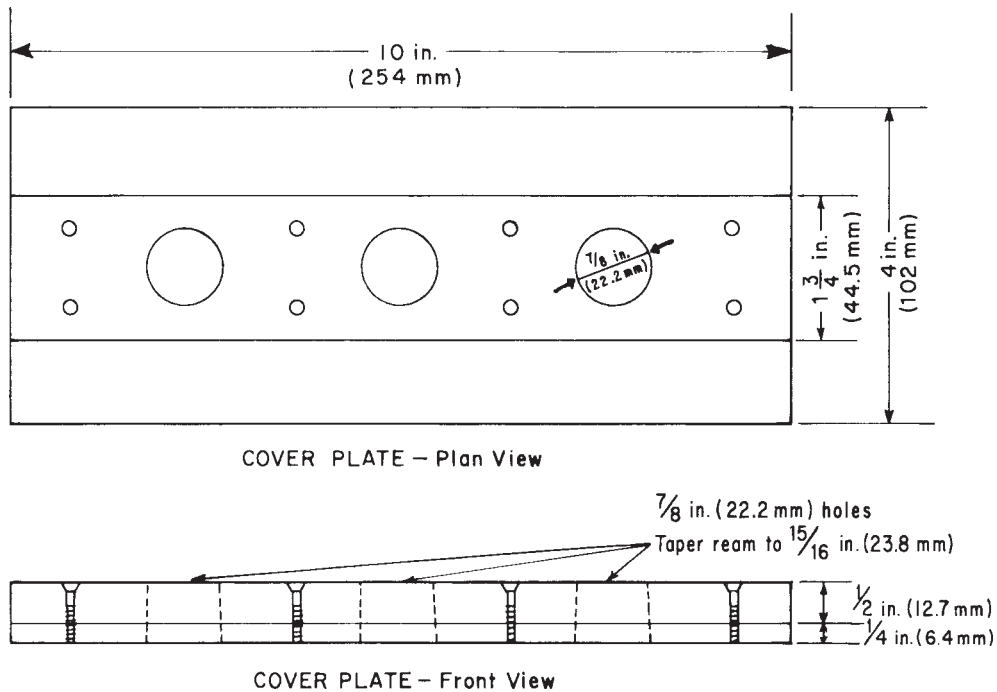

**FIG. 1 Sketch of Cover Plate for 2-in. (50-mm) Cube Mold**

solidification is complete, remove the cubes from the mold without breaking off the knob formed by the filling hole in the cover plate. Remove oil, sharp edges, and fins from the cubes and check the planeness of the bearing surfaces in the manner described in Test Method C 109. After storage at room temperature to the desired age, but not less than 2 h, test cubes in compression following the procedure described in Test Method C 109, and calculate the compressive strength.

NOTE 7—If desired, a plane phenol formaldehyde (bakelite) plate of 1/8-in. (3-mm) thickness, provided with three appropriately spaced filling holes, may be inserted between the cover plate and the mold to slow the rate of cooling of test specimens.

NOTE 8—The second filling helps to prevent the formation of a large void or shrinkage pipe in the body of a cube. However, such defects may occur no matter how much care is exercised, and it therefore is advisable to inspect the interior of tested sulfur mortar cubes for homogeneity whenever the strength values obtained are significantly lower than anticipated.

## 6. Capping Procedures

6.1 *Freshly Molded Cylinders*—Use only neat portland cement pastes (Note 9) to cap freshly molded cylinders. Make caps as thin as practicable. Do not apply the neat paste to the exposed end until the concrete has ceased settling in the molds, generally from 2 to 4 h after molding. During the molding of the cylinder, strike off the upper end even with or slightly below the plane of the rim of the mold. Remove free water and laitance from the top of the specimen immediately before capping. Form the cap by placing a conical mound of paste on the specimen and then gently pressing a freshly oiled capping plate on the conical mound until the plate contacts the rim of the mold. A very slight twisting motion may be required to extrude excess paste and minimize air voids in the paste. The capping plate must not rock during this operation. Carefully cover the capping plate and mold with a double layer of damp burlap and a polyethylene sheet to prevent drying. Removal of the capping plate after hardening may be accomplished by tapping the edge with a rawhide hammer in a direction parallel to the plane of the cap.

NOTE 9—Type I neat cement caps generally require at least 6 days to develop acceptable strength and Type III neat cement caps at least 2 days. Dry concrete specimens will absorb water from freshly mixed neat cement paste and produce unsatisfactory caps. Neat cement paste caps will shrink and crack on drying and, therefore, should be used only for specimens that are to be moist cured continuously until time of testing.

NOTE 10—High-strength gypsum caps soften and deteriorate on contact with water and cannot be used on freshly mixed concrete or stored in a moist room for more than very brief periods.

### 6.2 *Hardened Concrete Specimens:*

6.2.1 *General*—If an end of a specimen has a coating or deposit of oily or waxy materials that would interfere with the bond of the cap, remove such coatings or deposits. If necessary, the ends of a specimen may be slightly roughened with a steel file or wire brush to produce proper adhesion of the cap. If desired, capping plates may be coated with a thin layer of mineral oil or grease to prevent the capping material from adhering to the surface of the plate.

6.2.2 *End Condition*—The distance of any point on an uncapped end from a plane that passes through the highest point of the end surface and is perpendicular to the axis of the

cylinder shall not exceed 1/8 in. (3 mm) (Note 11). If the end exceeds this limit, the end of the cylinder shall be cut, lapped or ground prior to capping.

NOTE 11—This provision is to control the difference between the thickest and thinnest parts of a cap. The distance may be checked using a square with one blade touching the cylinder parallel to the cylinder axis and the other blade touching the highest point on the end of the cylinder. The distance between the blade of the square and the lowest point on the end of the cylinder is measured.

6.2.3 *Capping with High-Strength Gypsum Plaster or Neat Cement Paste*—Mix the paste as described in Section 2. Do not exceed the water-cement ratio determined in qualification tests. Form the caps as described in 6.1 using capping plates described in 4.1 to achieve the alignment required in 4.2 (Note 12). Generally, capping plates may be removed within 45 min with gypsum cement pastes and after 12 h with neat cement paste, without visibly damaging the cap.

NOTE 12—A number of methods have been used to obtain the desired perpendicularity of the cap to the axis of the cylinder. A mound of paste can be placed on a capping plate and the specimen lowered into it. A bull's-eye level on the top of the cylinder helps obtain alignment. A mound of paste can be placed on top of the cylinder and a capping plate pressed into it, again using the bull's-eye level. A better system is to make a half-height mold with a vertical split so that it can be slipped over the hardened cylinder. A clamp is used to position the mold and to ensure the required cap thickness. The mound of paste can then be placed either on a capping plate or on top of the cylinder and pressed until the plate contacts the mold. As noted earlier, very stiff paste may require excessive pressure and produce thick or defective caps.

6.2.4 *Capping with Sulfur Mortar*—Prepare sulfur mortar for use by heating to about 265°F (130°C) as determined by an all-metal thermometer inserted near the center of the mass. Check the temperature at approximately hourly intervals during capping. Empty the pot and recharge with fresh material at intervals to ensure that the oldest material in the pot has not been used more than five times. When capping concrete cylinders with a compressive strength of 5000 psi (35 MPa) or greater, it is not permitted to reuse compound recovered from the capping operation or old caps. Fresh sulfur mortar must be dry at the time it is placed in the pot as dampness may cause foaming. Keep water away from molten sulfur mortar for the same reason. The capping plate or device should be warmed before use to slow the rate of hardening and permit the production of thin caps. Oil the capping plate lightly and stir the molten sulfur mortar immediately prior to pouring each cap. The ends of moist cured specimens shall be dry enough at the time of capping to preclude the formation of steam or foam pockets under or in the cap larger than 1/4 in. (6 mm) in diameter. Replace caps with steam pockets or voids larger than 1/4 in. (6 mm) (Note 13). To ensure that the cap is bonded to the surface of the specimen, the end of the specimen shall not be oiled prior to the application of the cap. When using a vertical device, pour the mortar onto the surface of the capping plate, lift the cylinder above the plate and contact the cylinder sides with the guides, slide the cylinder down the guides onto the capping plate while keeping constant contact with the alignment guides. The cylinder end should continue to rest on the capping plate with cylinder sides in positive contact with the

alignment guides until the mortar has hardened. Use sufficient material to cover the cylinder end after the sulfur mortar solidifies.

NOTE 13—Periodically, the sulfur mortar cap should be examined after testing for air or steam pockets in the cap. Before testing, the cap can be tapped with a coin or rubbed with a light metal implement to see if a hollow sound can be detected. Caps with hollow areas should be removed and recapped.

6.2.4.1 **Caution:** Hydrogen sulfide gas may be produced during capping when sulfur mortar is contaminated with organic materials such as paraffin or oil. The gas is colorless and has a notoriously bad odor of rotten eggs; however, the odor should not be relied upon as a warning sign, since the sensitivity to the odor disappears rapidly on exposure. High concentrations are lethal and less concentrated dosages may produce nausea, stomach distress, dizziness, headache, or irritation of the eyes. For this and other reasons, the melting pot must be located under a hood with an exhaust fan and that capping area must be well ventilated.

#### 6.2.5 Daily Check:

6.2.5.1 During each day's capping operation, check the planeness of the caps prior to compression testing on at least three specimens, selected at random, representing the start, middle, and end of the run. Check planeness with a straight-edge and feeler gage, making a minimum of three measurements on different diameters to ensure that the surface of the caps do not depart from a plane by more than 0.002 in. (0.05 mm). Check also for hollow areas (Note 13). Record the results of these determinations in the quality control documentation for the laboratory. If caps fail to satisfy the planeness requirement or have hollow areas, remove and reapply the caps.

*ASTM International takes no position respecting the validity of any patent rights asserted in connection with any item mentioned in this standard. Users of this standard are expressly advised that determination of the validity of any such patent rights, and the risk of infringement of such rights, are entirely their own responsibility.*

*This standard is subject to revision at any time by the responsible technical committee and must be reviewed every five years and if not revised, either reapproved or withdrawn. Your comments are invited either for revision of this standard or for additional standards and should be addressed to ASTM International Headquarters. Your comments will receive careful consideration at a meeting of the responsible technical committee, which you may attend. If you feel that your comments have not received a fair hearing you should make your views known to the ASTM Committee on Standards, at the address shown below.*

*This standard is copyrighted by ASTM International, 100 Barr Harbor Drive, PO Box C700, West Conshohocken, PA 19428-2959, United States. Individual reprints (single or multiple copies) of this standard may be obtained by contacting ASTM at the above address or at 610-832-9585 (phone), 610-832-9555 (fax), or service@astm.org (e-mail); or through the ASTM website (www.astm.org).*

6.2.5.2 During each day's compressive strength testing operation, check the thickness of caps on at least three specimens, selected at random, from the start, middle, and end of that day's operation. After completing the compression test, recover at least six pieces of capping material from the top of the selected specimen (Note 14). The pieces shall be selected at random and be distributed over the entire area of the cap. The selected pieces shall have debonded completely from the concrete. Measure and record the thicknesses of the pieces to the nearest 0.01 in. (0.2 mm) using a micrometer, caliper or other thickness measurement device. Compare the average and maximum thicknesses with the values in Table 1. Record the results of the thickness determinations in the quality control documentation for the laboratory.

NOTE 14—Caps may be removed by using a hammer and sharp chisel. Place the chisel tip at the bond line and nearly parallel with the plane of the cap so as to create a wedging action when the chisel is struck with the hammer. Recovery of the entire cap may be simplified by placing duct tape over the cap prior to attempting its removal. The tape will keep the pieces of capping material from being dispersed during removal and will simplify the selection of pieces uniformly distributed over the cap area.

## 7. Protection of Specimens After Capping

7.1 Maintain moist cured specimens in a moist condition between the completion of capping and the time of testing by returning them to moist storage or wrapping them with a double layer of wet burlap. Do not store specimens with gypsum plaster caps immersed in water or for more than 4 h in a moist room. Protect plaster caps from dripping water.

7.2 Do not test capped specimens before the capping material has sufficient time to develop the strength required in 5.1.