



Standard Specification for the Manufacture, Performance, and Testing of Metal Suspension Systems for Acoustical Tile and Lay-in Panel Ceilings¹

This standard is issued under the fixed designation C 635/C 635M; the number immediately following the designation indicates the year of original adoption or, in the case of revision, the year of last revision. A number in parentheses indicates the year of last reappraisal. A superscript epsilon (ε) indicates an editorial change since the last revision or reappraisal.

This standard has been approved for use by agencies of the Department of Defense.

1. Scope

1.1 This specification covers metal ceiling suspension systems used primarily to support acoustical tile or acoustical lay-in panels.

1.2 Some suspension systems incorporate locking assembly details that enhance performance by providing some continuity or load transfer capability between adjacent sections of the ceiling grid. The test methods included in this specification do not provide the means for making a complete evaluation of continuous beam systems, nor for assessing the continuity contribution to overall system performance. However, the test methods can be used for evaluating primary structural members in conjunction with secondary members that interlock, as well as with those of noninterlocking type.

1.3 While this specification is applicable to the exterior installation of metal suspension systems, the atmospheric conditions and wind loading require additional design attention to ensure safe implementation. For that reason, a specific review and approval should be solicited from the responsible architect and engineer, or both, for any exterior application of metal suspension systems in the construction of a new building or building modification.

1.4 The values stated in either SI units or inch-pound units are to be regarded separately as standard. The values stated in each system may not be exact equivalents; therefore, each system shall be used independently of the other. Combining values from the two systems may result in non-conformance with the standard.

1.5 The following safety hazards caveat pertains only to the test methods described in this specification. *This standard does not purport to address all of the safety concerns, if any, associated with its use. It is the responsibility of the user of this standard to establish appropriate safety and health practices and determine the applicability of regulatory limitations prior to use.*

2. Referenced Documents

2.1 *ASTM Standards:*²

B 117 Practice for Operating Salt Spray (Fog) Apparatus

3. Terminology

3.1 *Definitions:*

3.1.1 Where these terms appear in this specification they shall have the meaning herein indicated as follows:

3.1.1.1 *backing board*— a flat sheet of gypsum board to which acoustical tile is attached using adhesive, screws, staples, or other suitable means (Fig. 1c).

3.1.1.2 *bow*—the maximum component of deviation in the vertical plane of a main runner, cross runner, or wall molding where the centroidal axis of these structural components has been permanently deformed from end to end into the shape of a simple regular curve during the manufacturing process (Fig. 2).

NOTE 1—The meanings for *bow* and *camber* given here may differ from those applied elsewhere.

3.1.1.3 *camber*—the maximum component of deviation in the horizontal plane of a main runner, cross runner, or wall molding where the centroidal axis of these structural components has been permanently deformed from end to end into the shape of a simple regular curve during the manufacturing process (Fig. 2).

3.1.1.4 *carrying channel or hanging channel*—the three-sided or “[”-shaped metal sections that support the entire structural grid network in some forms of mechanical ceiling suspension systems (Fig. 1b). The carrying channels are usually suspended by hanger wires from the existing structure and the main runners are then attached to the channels.

3.1.1.5 *ceiling suspension system*—the entire network or grid of structural components, as defined by the ceiling suspension system manufacturer, that provides support for

¹ This specification is under the jurisdiction of ASTM Committee E33 on Building and Environmental Acoustics and is the direct responsibility of Subcommittee E33.04 on Application of Acoustical Materials and Systems.

Current edition approved Oct. 1, 2007. Published October 2007. Originally approved in 1969. Last previous edition approved in 2004 as C 635 – 04.

² For referenced ASTM standards, visit the ASTM website, www.astm.org, or contact ASTM Customer Service at service@astm.org. For *Annual Book of ASTM Standards* volume information, refer to the standard's Document Summary page on the ASTM website.

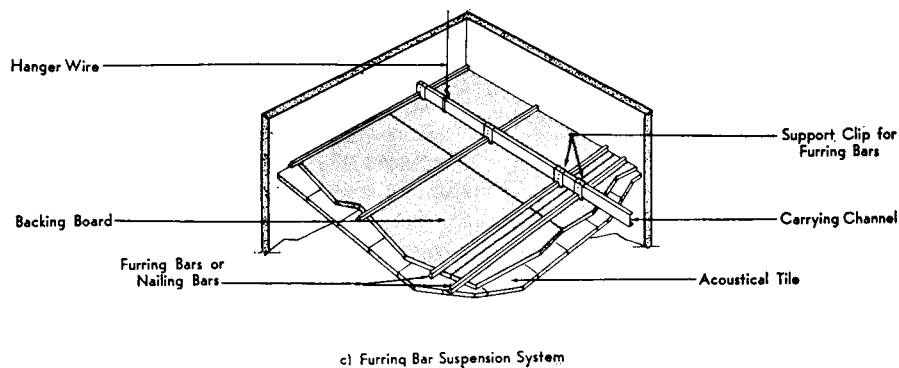
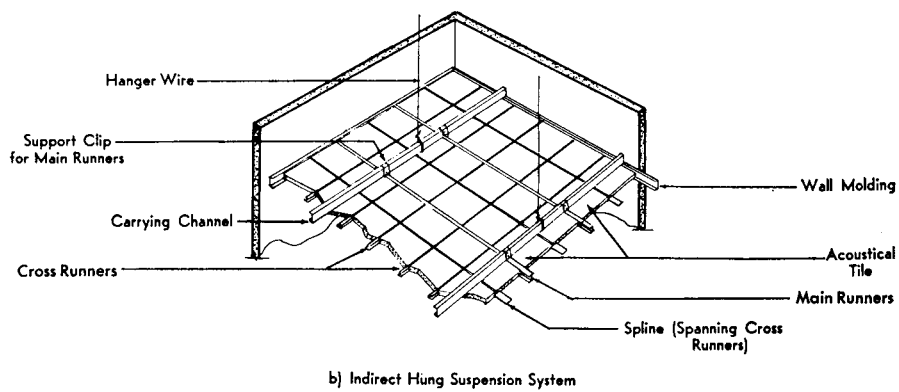
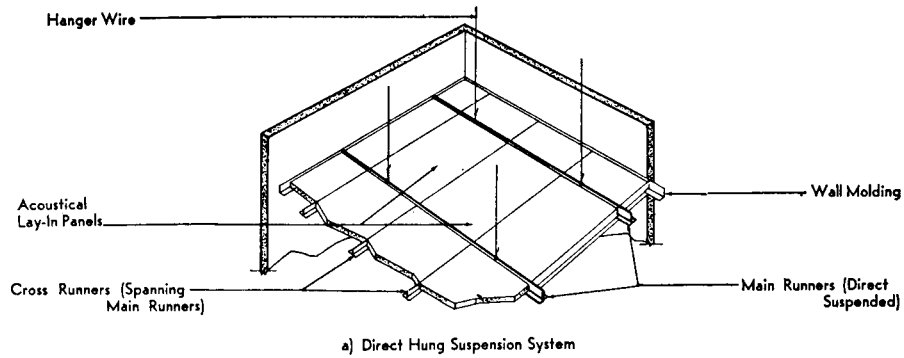

FIG. 1 Three Types of Ceiling Suspension Systems Showing All Components

acoustical ceiling tile, acoustical ceiling panels, lighting fixtures, and air diffusers.

3.1.1.6 *cross runner*— the secondary or cross beams of a mechanical ceiling suspension system (Fig. 1, a and b). The cross runners usually support only the acoustical tile. In some forms of suspension systems, however, the cross runners also provide support for lighting fixtures, air diffusers, and other cross runners.

3.1.1.7 *hanger wire*— the wire employed to suspend the acoustical ceiling from the existing structure (wood joists, steel bar joists, steel beams, concrete slabs, etc.) (Fig. 1).

3.1.1.8 *horizontal plane* (of a structural component of a ceiling suspension system)—a plane parallel to the plane of the ceiling which passes through the centroidal axis of the member (Fig. 2).

3.1.1.9 *interlocking*—a ceiling system where the cross runners are connected to the main runner or other cross runners, or both, at intervals controlled by slots, holes, etc. in the main runners.

3.1.1.10 *main runner*— the primary or main beams of the type of ceiling suspension system in which the structural members are mechanically locked together (Fig. 1, a and b).

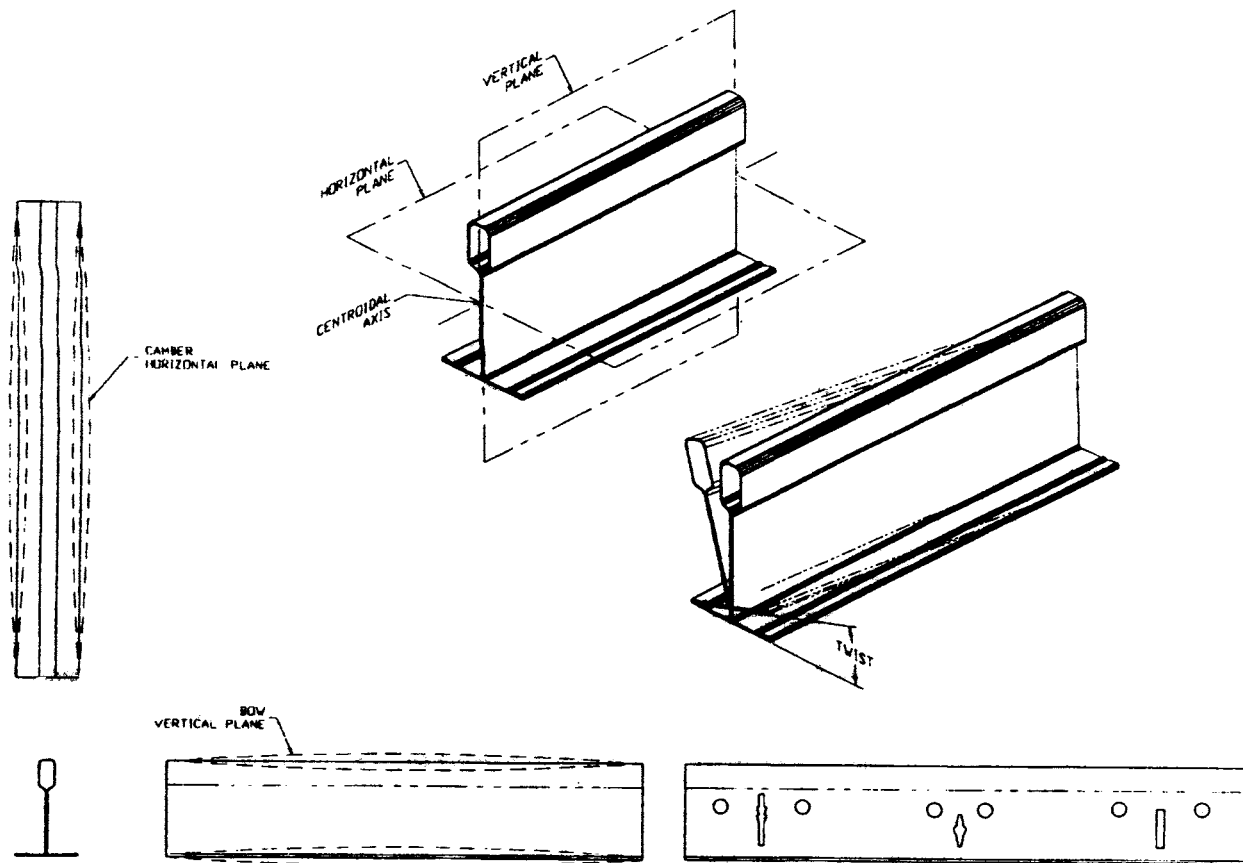

FIG. 2 Diagrams Showing Camber, Bow, and Twist

The main runners provide direct support for cross runners, and may support lighting fixtures and air diffusers. In addition, the acoustical tile may also be directly supported by the main runners. In some forms of mechanical ceiling suspension systems, the main runners are supported by hanger wires attached directly to the existing structure. In other forms, the main runners (also referred to as “H” runners, “Z” bars, etc.) are installed perpendicular to carrying channels and are supported by specially designed sheet metal or wire clips attached to the carrying channels.

3.1.1.11 *nailing bar or furring bar*—the continuous sheet metal strips to which a backing board is attached using either nails or screws (Fig. 1c). The nailing bars are installed perpendicular to and supported by the carrying channels.

3.1.1.12 *non-interlocking*—a ceiling system that does not comply with the specifications stated in the definition of interlocking.

3.1.1.13 *spline*—a strip of metal or fiber inserted in the kerfs of adjacent acoustical tile to form a concealed mechanical joint seal (Fig. 1b).

3.1.1.14 *twist*—the angle of rotation measured in a transverse plane between the two end cross sections of a main runner, cross runner, or wall molding which has been permanently deformed during the process of manufacturing (Fig. 2).

3.1.1.15 *vertical plane* (of a structural component of a ceiling suspension system)—a plane perpendicular to the plane of the ceiling which passes through the centroidal axis of the member (Fig. 2).

3.1.1.16 *wall molding*—the edge angles or channels of a mechanical ceiling suspension system that are attached to a wall (Fig. 1, a and b). The wall molding provides support for the acoustical tile, main runners and cross runners that are located at the periphery of the ceiling.

4. Classification

4.1 The structural performance required from a ceiling suspension system shall be defined by the specifying authority in terms of a suspension system structural classification.

4.1.1 The structural classification of ceiling suspension systems shall be based on the load-carrying capacity of the main runners of the structural network. Load-carrying capacity as used herein is based on the more stringent requirement of esthetic acceptance rather than the less confining prevention of structural failure. The criterion is the arbitrary but widely established limit of deflection to $1/360$ of the span between supports.

4.1.2 The load-carrying capacity shall be the maximum uniformly distributed load (pounds per linear foot [N/m]) that a simply supported main runner section having a span length of

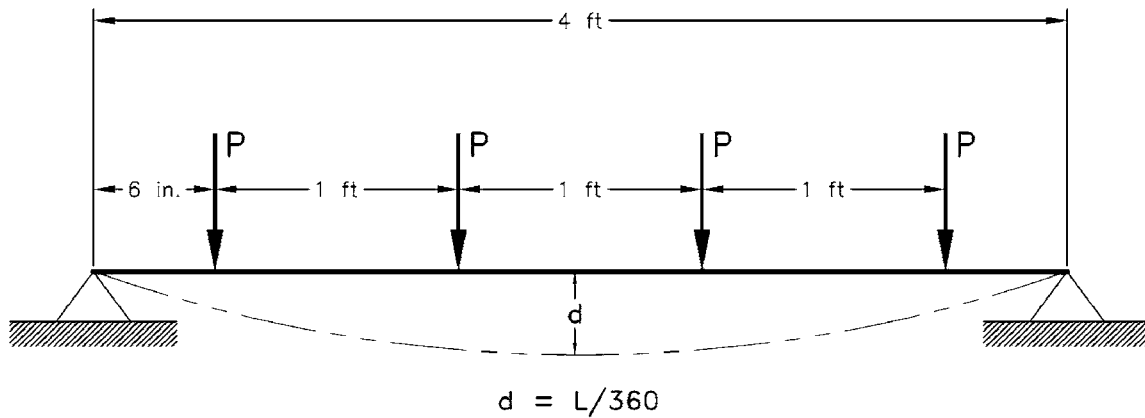

FIG. 3 Load-Carrying Test Configuration for Inch/Pound Units

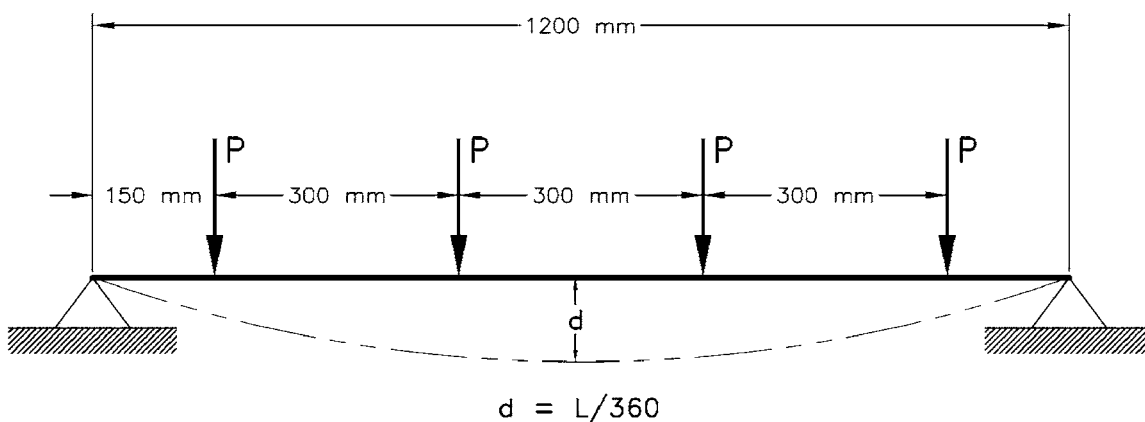

FIG. 4 Load-Carrying Test Configuration for Inch/Pound Units

4 ft, 0 in. [1200 mm] is capable of supporting without the mid-span deflection exceeding 0.133 in. [3.33 mm] or $1/360$ of the 4 ft, 0 in. [1200 mm] span length, as tested in accordance with the method described in Section 8.

4.1.3 The structural classification or grade of ceiling suspension systems shall be determined by the capability of main runners or nailing bars to support a uniformly distributed load. These classifications shall be:

4.1.3.1 *Light-Duty Systems*, used where ceiling loads other than acoustical tile or lay-in panels are not anticipated, such as residential and light commercial structures.

4.1.3.2 *Intermediate-Duty Systems*, used where ceiling loads other than acoustical tile or lay-in panels (light fixtures, air diffusers, etc.) are anticipated, such as ordinary commercial structures.

4.1.3.3 *Heavy-Duty Systems*, used where the quantities and weights of ceiling fixtures (lights, air diffusers, etc.) are greater than those for an ordinary commercial structure.

4.1.4 For the purpose of determining the structural classification of main runner members as covered in 4.1.2, their simple-span, minimum load-carrying capabilities, when tested in accordance with the test method described in Section 10, shall be listed as shown in Table 1 and Table 2.

4.2 Cross runners shall be capable of carrying the load specified by the manufacturer without exceeding the maximum allowable deflection equal to $1/360$ of its span.

4.3 The design and definition of the suspension system shall be the responsibility of the manufacturer. Included is selection of appropriate materials, metal thicknesses, dimensions of necessary component section configurations, design of special hanger and assembly devices, and provision for whatever accessory items are needed to ensure satisfactory ceiling performance within the scope of this specification.

4.3.1 System manufacturers may provide supplementary data describing load deflection capabilities of main runners in each classification for spans other than 4 ft [1200 mm].

4.4 Where specialized loading conditions that are outside the scope of this specification exist, the manufacturer should be consulted for his recommendations; and, he may furnish engineering data as required. Specification or design of super-structure anchors or fasteners are not the responsibility of the ceiling system manufacturer unless specified by the ceiling system manufacturer as part of the suspension system.

5. Dimensional Tolerance

5.1 Suspension system *structural members* shall conform to the following tolerance requirements:

5.1.1 *Metal Thickness:*

5.1.1.1 For *steel systems* the thickness of metal used in main runners, cross runners, wall moldings, splines or nailing bars shall be stated by the suspension system manufacturer in

TABLE 1 Minimum Load-Carrying Capabilities of Main Runners - Inch/Pound Units

| Suspension System | Duty Classification | Applied Load (P) | Equivalent Uniform Load | Allowable Midspan Deflection (d) |
|-------------------|---------------------|------------------|-------------------------|----------------------------------|
| | | lb | lb/ft | in. |
| Direct Hung | Light | 5.0 | 5.0 | 0.133 |
| | Intermediate | 12.0 | 12.0 | 0.133 |
| | Heavy | 16.0 | 16.0 | 0.133 |
| Indirect Hung | Light | 2.0 | 2.0 | 0.133 |
| | Intermediate | 3.5 | 3.5 | 0.133 |
| | Heavy | 8.0 | 8.0 | 0.133 |
| Furring Bar | Light | 4.5 | 4.5 | 0.133 |
| | Intermediate | 6.5 | 6.5 | 0.133 |
| | Heavy | ... | ... | ... |

d=span/360

TABLE 2 Minimum Load-Carrying Capabilities of Main Runners - SI units

| Suspension System | Duty Classification | Applied Load (P) | Equivalent Uniform Load | Allowable Midspan Deflection (d) |
|-------------------|---------------------|------------------|-------------------------|----------------------------------|
| | | N | N/m | mm. |
| Direct Hung | Light | 22.7 | 75.7 | 3.33 |
| | Intermediate | 54.3 | 181.0 | 3.33 |
| | Heavy | 72.5 | 241.7 | 3.33 |
| Indirect Hung | Light | 9.1 | 30.3 | 3.33 |
| | Intermediate | 15.9 | 53.0 | 3.33 |
| | Heavy | 36.3 | 121.0 | 3.33 |
| Furring Bar | Light | 20.4 | 68.0 | 3.33 |
| | Intermediate | 29.4 | 98.0 | 3.33 |
| | Heavy | ... | ... | ... |

d=span/360

Equivalent Uniform Load (n/m) obtained by the following relationship: P/0.3 m

published literature. The thickness in thousandths of an inch of metal and the allowable thickness variation for the component shall be stated.

5.1.1.2 For *aluminum systems* the thickness of metal used in main runners, cross runners, wall moldings, or splines shall be stated by the suspension system manufacturer in published literature. The thickness in thousandths of an inch of metal and the allowable thickness variation for the component shall be stated.

5.1.2 Straightness:

5.1.2.1 The amount of bow, camber, or twist in main runners, cross runners, wall molding, splines, or nailing bars of various lengths shall not exceed the values shown in **Table 3**.

5.1.2.2 Main runners, cross runners, wall moldings, splines, or nailing bars of ceiling suspension systems shall not contain local kinks or bends.

5.1.3 Length:

5.1.3.1 The variation in the specified length of main runner sections or cross runner sections that are part of an interlocking grid system shall not exceed ± 0.010 in./4 ft [0.25 mm/1200 mm].

5.1.3.2 The variation in the specified spacing of slots or other cutouts in the webs of main runners or cross runners that are employed in assembling a ceiling suspension grid system shall not exceed ± 0.010 in. [0.25 mm].

5.1.4 Over-all Cross-section Dimensions:

5.1.4.1 For *steel systems*, the overall height of the cross section of main runners, cross runners, wall molding, or nailing bar shall be the specified dimensions ± 0.030 in. [0.75 mm]. The width of the cross section of exposed main runners or cross runners shall be the specified dimension ± 0.008 in. [0.20 mm].

5.1.4.2 For *aluminum systems*, the overall height of the cross section and the allowable variation of main runners, cross runners, or wall molding shall be stated by the suspension system manufacturer in published literature and price lists. The width and allowable variation of the cross section of exposed main runners or cross runners shall be similarly stated.

5.1.5 Section Squareness:

5.1.5.1 Intersecting webs and flanges of structural members ("T", "T", or "Z" sections) shall form angles between them of $90 \pm 2^\circ$. If deviations from squareness at more than one such

TABLE 3 Straightness Tolerances of Structural Members of Suspension Systems

| Deformation | Straightness Tolerances |
|-------------|---|
| Bow | $\frac{1}{32}$ in. [0.80 mm] in any 2 ft [600 mm] |
| Camber | $\frac{1}{32}$ in. [0.80 mm] in any 2 ft [600 mm] |
| Twist | 1° in any 2 ft [600 mm] |

intersection are additive with respect to their use in a ceiling, the total angle shall not be greater than 2°.

5.1.5.2 The ends of structural members that abut or intersect other members in exposed grid systems shall be cut perpendicular to the exposed face, 90° + 0, – 2°.

5.2 Suspension system assembly devices shall satisfy the following requirements and tolerances.

5.2.1 The design of and dimensional tolerances set by the manufacturer for accessory items such as formed wire hangers, spring spacer clips, tile retainers, and spacer bars shall be such as to ensure satisfactory performance of their intended function in the suspension system. Failure attributable to such accessories to control alignment, prevent undesirable rotation, or other unsatisfactory performance that results in unfavorable acoustical tile ceiling appearance, will be cause for their rejection.

5.2.2 A joint connection shall be judged suitable both before and after ceiling loads are imposed if the joint provides sufficient alignment so that:

5.2.2.1 The horizontal and the vertical displacement of the exposed surfaces of two abutting main runners does not exceed 0.015 in. [0.40 mm].

5.2.2.2 There shall be no visually apparent angular displacement of the longitudinal axis of one runner with respect to the other.

5.2.3 Assembly devices shall provide sufficient spacing control so that horizontal gaps between exposed surfaces of either abutting or intersecting members shall not exceed 0.020 in. [0.50 mm].

5.2.4 Spring wire clips used for supporting main runners shall maintain tight contact between the main runners and the carrying channels when the ceiling loads are imposed on the runners.

6. Coatings and Finishes for Suspension System Components

6.1 *Protective Coatings*—Component materials that oxidize or corrode when exposed to normal use environments shall be provided with protective coatings as selected by the manufacturer except for cut or punched edges fabricated after the coating is applied.

6.1.1 *Sheet Steel*—Components fabricated from sheet steel shall be given an electrogalvanized, hot dipped galvanized, cadmium, or equal protective coating.

6.1.2 *Aluminum Alloy*—Components fabricated from aluminum alloys shall be anodized or protected by other suitable technique as selected by the manufacturer.

6.1.3 *Other Component Materials*—Components formed from other candidate materials shall be provided with a suitable protective coating.

6.2 *Finishes*—If the protective coatings identified in 6.1 provide a finish that is satisfactory for the intended use of nonexposed individual components in a ceiling suspension system, no further coating of such items shall be required. Exposed suspension system components shall be provided with a decorative finish by the manufacturer.

6.2.1 *Color and Texture*:

6.2.1.1 The color and texture of components shall be determined by the manufacturer and shall be appropriate to the use of the component in the suspension system.

6.2.1.2 The limits of variability in color, texture, and gloss of finishes for exposed components shall be available, upon request, from the manufacturer in the form of standard color-texture chips or painted samples.

6.2.1.3 Prior to ordering, the purchaser shall determine if finishes of standard suspension system components are satisfactory for a specific installation, either matching, harmonizing, or contrasting with selected acoustical panels or tile.

6.2.1.4 If nonstandard color or texture, or both, finishes are required on suspension system components, this will constitute a special order item arranged for, and agreed upon in advance between the purchaser and the seller.

6.2.2 *Adhesion and Resilience*—Finishes shall exhibit good adhesion properties and resilience so that chipping or flaking does not occur as a result of the manufacturing process.

6.3 *Coating Classification for Severe Environment Performance*—In order to provide for suitably protected components for acoustical ceilings that might be subjected to the severe environmental conditions of high humidity and salt spray (fog), or both, and when such components are so specified (and specifically ordered from ceiling suspension system manufacturers), coating can be ranked according to their ability to protect the components of suspension systems from deterioration.

6.3.1 *Salt Spray (Fog) Test*—Practice B 117, conducted in accordance with the following test conditions for such ranking.

6.3.1.1 *Salt Solution*—5 parts by weight sodium chloride (NaCl) to 95 parts distilled water.

6.3.1.2 *Humidity in Chamber*—90 % relative humidity.

6.3.1.3 *Temperature in Chamber*—90°F [32°C].

6.3.1.4 *Exposure Period*—96 h continuous.

6.3.1.5 *Report*—Upon request the manufacturer shall provide photographs showing worst corrosion conditions on components and shall provide comments regarding corrosion that occurs on cut metal edges, on galvanized surfaces without paint, on galvanized and painted surfaces, at edges rolled after being painted, and on any change of paint color or gloss that is apparent at the conclusion of the test. Color and gloss inspection of the component shall be made after washing in a mild soap solution.

6.3.2 *High-Humidity Test*—The test and inspection shall be identical to that of the salt spray test, 6.3.1, except that distilled water instead of salt solution (see 6.3.1.1) shall be used.

6.3.3 The installation of metal suspension systems in any exterior application shall be considered as use in a severe environment.

7. Inspection

7.1 When items not meeting specification requirements are discovered, their existence shall be called to the attention of the manufacturer prior to installation. Possible use of such items may be adjudicated among the responsible parties involved, based on the nature of the deficiency and the effect on the performance of the ceiling.

7.2 When rejection occurs, the manufacturer or his agent shall have the right to examine the rejected material. After removal of the portion not conforming to the specification, resubmission of the lot shall be permitted.

8. Experimental Loading Facility

8.1 Perform the experimental loading of structural members in a manner that closely simulates their use in suspension systems, except that all loading will be with incremental weights rather than acoustical material, etc. Span distances, spacing between secondary supports, etc., shall all be typical of ceiling grid designs in which the structural member is used.

8.1.1 *Support Frame*— Provide a rectangular support frame having the essential features of the unit described below:

8.1.1.1 The frame (Fig. 5) shall have the capability for length adjustment to permit testing of structural members on clear spans for a maximum of 8 ft [2400 mm] to a minimum of 3 ft [900 mm]. It shall have the capability for overall width adjustment from a maximum of 4 ft [1200 mm] to a minimum of 2 ft [600 mm].

8.1.1.2 The support frame shall have sufficient stiffness so that no significant deflection occurs within the frame during load tests of suspension system structural members.

8.1.1.3 The support frame may be either ceiling mounted or floor supported.

8.1.2 *Test Loading*— Do not use the main runner weight for evaluating load-deflection performance. Include one half of the weight of the cross runners as part of the test load.

8.1.2.1 Provide the individual test weights appropriate for evaluating the structural member. Provide loads weighing up to 1 lb [4.4 N] so that their actual weight is within 0.01 lb [0.045 N] of their marked weight. Weights over 1 lb [4.4 N] shall be within 1 % of their marked weight. Conveniently provide loading weights of the sizes required by weighing load shot into cloth bags and tying them closed.

8.1.2.2 Provide a sufficient number of weights of suitable mass to permit evaluation of the structural member through its elastic range by loading in approximately ten equal load increments. When elastic performance of the member under

test is exceeded, continue loading using a suitably reduced load increment until significant section yielding has been produced.

8.1.2.3 Apply a complete load increment, simulating a uniformly distributed load imposed over the entire section length, before measuring the deflection of the structural member.

8.1.2.4 Make provision for imposing test loads on the structural member in a symmetrical manner. Avoid eccentric loading that initiates lateral buckling of structural members.

8.1.3 *Deflection Measurements*—Observe the deflection of structural members after application of each full load increment during the entire test.

8.1.3.1 Measure the deflection of structural members being tested with dial indicators capable of direct reading to 0.001 in. [0.025 mm].

8.1.3.2 Mount dial indicators from a separate gage frame (Fig. 5) having three points of support. Support the gage frame from the test loading frame and properly position it to locate the dial stems vertically over the structural member being tested.

8.1.3.3 The dial indicators used shall have sufficient travel capability to permit the deflection performance of the structural members to be observed during the entire test without requiring resetting.

9. Structural Members

9.1 The manufacturer shall determine the load-deflection performance.

9.1.1 The structural members tested shall be identical to the sections used in the final system design. All cutouts, slots, etc., as exist in the system component shall be included in the sections evaluated.

9.1.2 Fire rated main runner/cross runner fire expansion relief cutouts shall be evaluated for load performance where

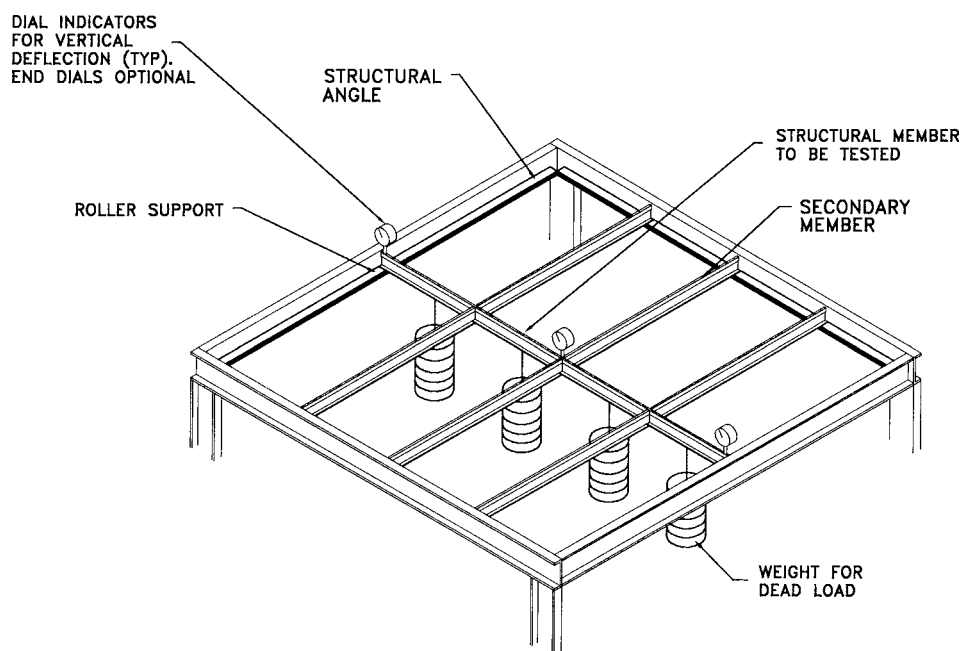

FIG. 5 Schematic Diagram of Experimental Loading Facility

field application of the expansion relief is designed to be more than 3 in. [75 mm] from the closest support point.

9.1.3 Allowable mill variations of sheet stock thickness can have a significant effect on section stiffness and load carrying ability. Consequently, load-deflection studies of structural members shall utilize sections fabricated in accordance with the system manufacturers' published metal thicknesses and dimensions.

10. Procedure

10.1 The procedures used for evaluating performance of suspension system structural members shall utilize the general principle of following actual field installation practice wherever possible (see 8.1). As an example of the general procedure to be followed, the setup and testing of a primary structural member is described below.

10.1.1 *Experimental Setup*—In preparation for testing, adjust the length and width of the support frame to the typical grid dimensions that are established as appropriate to the evaluation of the structural member. Install the primary structural member along the longitudinal centerline of the frame and support it at points simulating its field application. Note that testing for classification of a suspension system (Section 4) requires testing with the primary structural member simply supported over a 4-ft [1200 mm] span (Fig. 6). Prevent lateral buckling of the section during testing by installing secondary members between the test system and the vertical sides of the test frame.

10.1.1.1 In actual ceiling installations, buckling of structural members is generally prevented by the lateral support provided by intersecting structural members and acoustical tile or lay-in panels. When secondary structural members of a noninterlock-

ing type are used in a grid system, they provide needed lateral support but make no direct contribution to the load-deflection performance of the primary structural member being tested. Where such secondary members are used, install them normal to the direction of the primary structural member and at the midpoint and quarterpoint locations along the test span length. In accordance with 8.1, do not use acoustical material. Support one end of such secondary members from the side of the test frame and the other from the flange of the primary structural member (Fig. 5). Clearances between the ends of the secondary structural member in the test setup shall be typical of that which exists in the actual ceiling grid. Any buckling tendency will be defeated as the secondary member, supported axially by the vertical side of the test frame, bears on the web of the primary structural member.

10.1.1.2 Where interlocking secondary structural members are used, assemble them into the central primary structural member being tested in customary fashion and using conventional center distance spacing. Support the other end of the secondary member simply from the perimeter support frame. No interlocking of the secondary member and the perimeter support frame shall be permitted. This type of setup provides a means for giving at least a partial recognition of the enhancement of load-carrying capability that interlocking structural members contribute to grid systems.

10.1.2 *Section Loading*— With the structural member to be evaluated installed in the support frame, position the gage frame to mount the vertical displacement deflection gages directly over the test section at the mid-span. As an option, additional deflection gages may be mounted at each end of the test section at the rest supports. The optional end gages may be used when a test section exhibits a tendency to compact at the rest supports. Position the gages to read zero with reference to a horizontal plane that runs through the supports of the structural member in the test support frame. Incorporate the weight of hanger wires, pans, etc., as part of the first incremental test load.

10.1.2.1 Apply the test weights (Fig. 3 and Fig. 4), simulating the weight of ceiling tile or panel, to the structural member starting 6 in. [150 mm] from the end supports, and at 1-ft [300 mm] intervals thereafter, always proceeding from the ends toward the center of the span in applying the load. After the first uniformly distributed load increment has been applied, measure and record the mid-span deflection of the structural member. Also record the end gage deflections when the end gages are present. Measure and record the loading of the structural member. Continue loading of the structural member in the same manner, applying successive increments of uniformly distributed load and observing the deflections after each increment. Continue loading until it is apparent that the test section has yielded.

10.1.2.2 Determine the load-deflection performance of secondary structural members of acoustical tile and lay-in panel ceiling systems similarly. Set up and test the units in a manner appropriate to their use in actual grid systems.

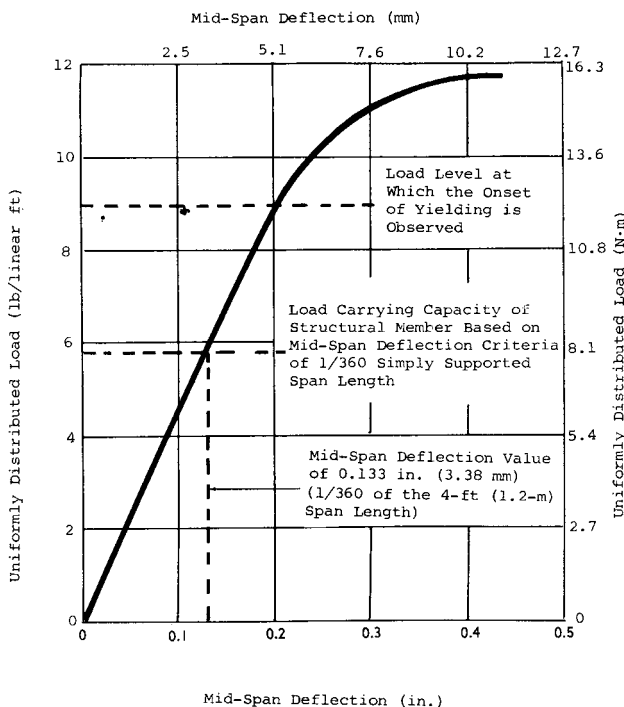

FIG. 6 Applied Load versus Mid-Span Deflection for a Hypothetical Structural Member Having a Simply Supported Span Length of 4 ft [1200 mm]

11. Experimental Data

11.1 A test log shall be prepared to record all pertinent data regarding the structural member being evaluated and the

principal accessory items used. Such information as the following shall be provided:

- 11.1.1 Manufacturer's name,
- 11.1.2 Suspension system identification,
- 11.1.3 Test system identification,
- 11.1.4 Description of section, measured overall height, width, and thickness of basic stock, type of material, section weight, etc.,
- 11.1.5 Test span length,
- 11.1.6 Spacing of lateral supports,
- 11.1.7 Identification of accessory items and how used,
- 11.1.8 Sketch of experimental setup, giving dimensions of grid, dial gage locations, load spacing, etc., and
- 11.1.9 Record of the incrementally applied uniformly distributed loads and the resultant mid-span deflection measurements for each loading. When end gages are used, subtract the average value of the two end gages from the corresponding mid-span deflection, and report the resultant net mid-span deflection for each increment. Subtracting the average end gage readings will compensate for vertical translation of the test section due to compaction at the rest supports.

12. Section Performance

12.1 The performance of structural members of suspension systems shall be represented by individual load-deflection plots obtained from tests performed at each different span length used in service.

12.2 Plot and average the results of replicate tests of the three individual sections, each tested on the same span length, to obtain a characteristic load-deflection curve for the structural member.

12.3 Use the average load deflection curve to establish the maximum uniformly distributed load that the structural member can successfully sustain prior to reaching the deflection limit of $\frac{1}{360}$ of the span length in inches [millimetres] (see Fig. 6).

12.4 Use the load deflection curve to establish the maximum loading intensity beyond which the structural member begins to yield.

13. Suspension System Performance

13.1 Published performance data for individual suspension systems shall be developed by the manufacturer upon the basis of results obtained from load-deflection tests of its principal structural members. Where a ceiling design incorporated a number of components, each of which experiences some deflection as used in the system, the additive nature of these displacements shall be recognized in setting an allowable system deflection criteria.

13.2 The specifying authority shall be responsible to see that the applied ceiling load, for example, light fixture, panels, etc., falls within the load recommendations provided by the suspension system manufacturer.

14. Keywords

14.1 acoustical; acoustical tile; ceiling; ceiling grid; metal ceiling suspension systems; panel ceilings

ASTM International takes no position respecting the validity of any patent rights asserted in connection with any item mentioned in this standard. Users of this standard are expressly advised that determination of the validity of any such patent rights, and the risk of infringement of such rights, are entirely their own responsibility.

This standard is subject to revision at any time by the responsible technical committee and must be reviewed every five years and if not revised, either reapproved or withdrawn. Your comments are invited either for revision of this standard or for additional standards and should be addressed to ASTM International Headquarters. Your comments will receive careful consideration at a meeting of the responsible technical committee, which you may attend. If you feel that your comments have not received a fair hearing you should make your views known to the ASTM Committee on Standards, at the address shown below.

This standard is copyrighted by ASTM International, 100 Barr Harbor Drive, PO Box C700, West Conshohocken, PA 19428-2959, United States. Individual reprints (single or multiple copies) of this standard may be obtained by contacting ASTM at the above address or at 610-832-9585 (phone), 610-832-9555 (fax), or service@astm.org (e-mail); or through the ASTM website (www.astm.org).