



Standard Practice for Determination of Thermal Resistance of Loose-Fill Building Insulation¹

This standard is issued under the fixed designation C 687; the number immediately following the designation indicates the year of original adoption or, in the case of revision, the year of last revision. A number in parentheses indicates the year of last reapproval. A superscript epsilon (ϵ) indicates an editorial change since the last revision or reapproval.

1. Scope

1.1 This practice presents a laboratory guide to determine the thermal resistance of loose-fill building insulations at mean temperatures between -20 and 55°C (-4 to 131°F).

1.2 This practice applies to a wide variety of loose-fill thermal insulation products including fibrous glass, rock/slag wool, or cellulosic fiber materials; granular types including vermiculite and perlite; pelletized products; and any other insulation material installed pneumatically or poured in place. It does not apply to products that change their character after installation either by chemical reaction or the application of binders or adhesives, nor does it consider the effects of structures, containments, facings, or air films.

1.3 Since this practice is designed for reproducible product comparison, it measures the thermal resistance of an insulation material which has been preconditioned to a relatively dry state. Consideration of changes of thermal performance of a hygroscopic insulation by sorption of water is beyond the scope of this practice.

1.4 The sample preparation techniques outlined in this practice do not cover the characterization of loose-fill materials intended for enclosed applications. For those applications, a separate sample preparation technique that simulates the installed condition will be required. However, even for those applications, some other aspects of this practice are applicable.

1.5 The values stated in SI units are to be regarded as the standard. The values given in parentheses are for information only.

1.6 *This standard does not purport to address all of the safety concerns, if any, associated with its use. It is the responsibility of the user of this standard to establish appropriate safety and health practices and determine the applicability of regulatory limitations prior to use.*

¹ This practice is under the jurisdiction of ASTM Committee C16 on Thermal Insulation and is the direct responsibility of Subcommittee C16.30 on Thermal Measurement.

Current edition approved Nov. 15, 2007. Published January 2008. Originally approved in 1971. Last previous edition approved in 2005 as C 687 – 05.

2. Referenced Documents

2.1 *ASTM Standards:*²

C 167 Test Methods for Thickness and Density of Blanket or Batt Thermal Insulations

C 168 Terminology Relating to Thermal Insulation

C 177 Test Method for Steady-State Heat Flux Measurements and Thermal Transmission Properties by Means of the Guarded-Hot-Plate Apparatus

C 518 Test Method for Steady-State Thermal Transmission Properties by Means of the Heat Flow Meter Apparatus

C 653 Guide for Determination of the Thermal Resistance of Low-Density Blanket-Type Mineral Fiber Insulation

C 739 Specification for Cellulosic Fiber Loose-Fill Thermal Insulation

C 1045 Practice for Calculating Thermal Transmission Properties Under Steady-State Conditions

C 1114 Test Method for Steady-State Thermal Transmission Properties by Means of the Thin-Heater Apparatus

C 1363 Test Method for Thermal Performance of Building Materials and Envelope Assemblies by Means of a Hot Box Apparatus

C 1373 Practice for Determination of Thermal Resistance of Attic Insulation Systems Under Simulated Winter Conditions

3. Terminology

3.1 Unless otherwise stated, the terms and definitions found in Terminology **C 168** are applicable herein.

4. Significance and Use

4.1 The thermal resistance, R , of an insulation is used to describe its thermal performance.

4.2 The thermal resistance of an insulation is related to the density and thickness of the insulation. It is desirable to obtain

² For referenced ASTM standards, visit the ASTM website, www.astm.org, or contact ASTM Customer Service at service@astm.org. For *Annual Book of ASTM Standards* volume information, refer to the standard's Document Summary page on the ASTM website.

test data on thermal resistances at thicknesses and densities related to the end uses of the product.

4.3 In normal use, the thickness of these products range from less than 100 mm (4 in.) to greater than 500 mm (20 in.). Installed densities depend upon the product type, the installed thickness, the installation equipment used, the installation techniques, and the geometry of the insulated space.

4.4 Loose-fill insulations provide coverage information using densities selected by manufacturers to represent the product settled densities. Generally, it is necessary to know the product thermal performance at a representative density. Some coverage charts utilize multiple densities to show that greater thickness installations usually result in higher installed densities. The use of multiple densities can be detected from the coverage chart by calculating the density for several different thermal resistance levels. (The density for a given thermal resistance can be calculated from the coverage chart by dividing the minimum mass per unit area by the minimum thickness.) If the calculated densities are significantly different at different thermal resistances, the multiple density strategy has been used.

4.5 When applicable specifications or codes do not specify the nominal thermal resistance level to be used for comparison purposes, a recommended practice is to use the R_{si} (metric) = 3.3 m²K/W (R_{IP} = 19 [h ft²F/Btu]) label density and thickness for that measurement.

4.6 If the density for test purposes is not available from the coverage chart, a test density shall be established by use of applicable specifications and codes or, if none apply, agreement between the requesting body and the testing organization.

4.7 Generally, thin sections of these materials are not uniform. Thus, the test thickness must be greater than or equal to the product's representative thickness if the results are to be consistent and typical of use.

NOTE 1—The representative thickness is specific for each product and is determined by running a series of tests in which the density is held constant but the thickness is increased. The representative thickness is defined here as that thickness above which there is no more than a 2 % change in the resistivity of the product. The representative thickness is a function of product blown density. In general, as the density decreases, the representative thickness increases. Fortunately, most products are designed to be blown over a small range of densities. This limited range yields a range of representative thicknesses between 100 to 200 mm (4 to 8 in.) for most products. To simplify the process for this Practice, the representative thickness for the C 687 tests shall be determined at the midpoint of the blown density range. Once this is accomplished, all thermal testing on this product is conducted at a thickness that is greater or equal to the representative thickness.

4.7.1 For this practice, the minimum test thickness shall be 100 mm (4 in.) or the representative thickness, whichever is larger. If the test is to represent an installation at a lesser thickness, the installed thickness shall be used.

4.8 Because of the high cost of construction and operation of large test equipment, it is impractical to test at the higher thicknesses at which products are used. For purposes of this practice, it is acceptable to estimate the thermal resistance at any thickness from the thermal resistivity obtained from tests on the product at the minimum test thickness (see 4.7.1) and at the density expected for the proposed thickness.

4.9 In principle, any of the standard methods for the determination of thermal resistance are suitable for loose-fill products. These include Test Methods C 177, C 518, C 1114, and C 1363. Of these test methods, the heat flow meter apparatus, Test Method C 518, is preferred because of its lower cost and shorter testing time.

4.10 The thermal resistance of low-density insulations depend upon the direction of heat flow. Unless otherwise specified, tests shall be performed for the maximum heat flow condition, that is, a horizontal specimen with heat flow-up.

4.11 Specimens shall be prepared in a manner consistent with the intended installation procedure. Products for pneumatic installation shall be pneumatically applied (blown), and products for pour-in-place installation shall be poured into specimen frames.

4.12 Loosefill insulation installed in attic applications will have heat flow up during the winter. At winter design conditions in many areas, the winter design temperature difference will cause convective heat transfer to occur within some loose-fill insulations. The procedure outlined in C 687 is not applicable to that measurement unless a C 1363 test apparatus is used to reproduce the correct boundary conditions. To determine how seasonal differences can affect product performance, use Practice C 1373. Practice C 1373 measures the expected winter thermal performance of loose-fill insulation under simulated winter design temperature conditions and provides specimen requirements necessary for that determination.

5. Apparatus

5.1 Thermal test apparatus used for this practice shall meet these requirements.

5.1.1 *Conformance to Standards*—The apparatus shall conform to all requirements of the ASTM thermal test method used.

5.1.2 *Size and Error*—The apparatus shall be capable of testing specimens up to at least 150-mm (6-in.) thickness with an estimated error not greater than 1 % attributed to thickness/guard dimensions. (Parametric studies using a mathematical model of the proposed apparatus will give insight to this evaluation. For example see Table 1 in the 1976 revision of Test Method C 518.³)

NOTE 2—Thermal test apparatus in use for this practice have overall plate dimensions of 457 to 1220 mm (18 to 48 in.) square with metering areas 152 to 457 mm (6 to 18 in.) square. Other sizes are acceptable if proper consideration of the size-thickness restrictions as outlined in the test method are observed in their design. (See Practice C 1045 for additional discussion.)

5.1.3 *Temperature*—As a minimum, the apparatus shall be capable of testing at a mean temperature of 23.9°C (75°F) with a temperature difference of 20 to 28°C (36 to 50°F). The equipment shall be calibrated at the same temperatures as the

³ See Table 1, "Maximum Spacing Between Warm and Cold Plates of Heat Flowmeter Apparatus," of Test Method C 518 – 76 published in 1985 *Annual Book of ASTM Standards*, Vol 04.06.

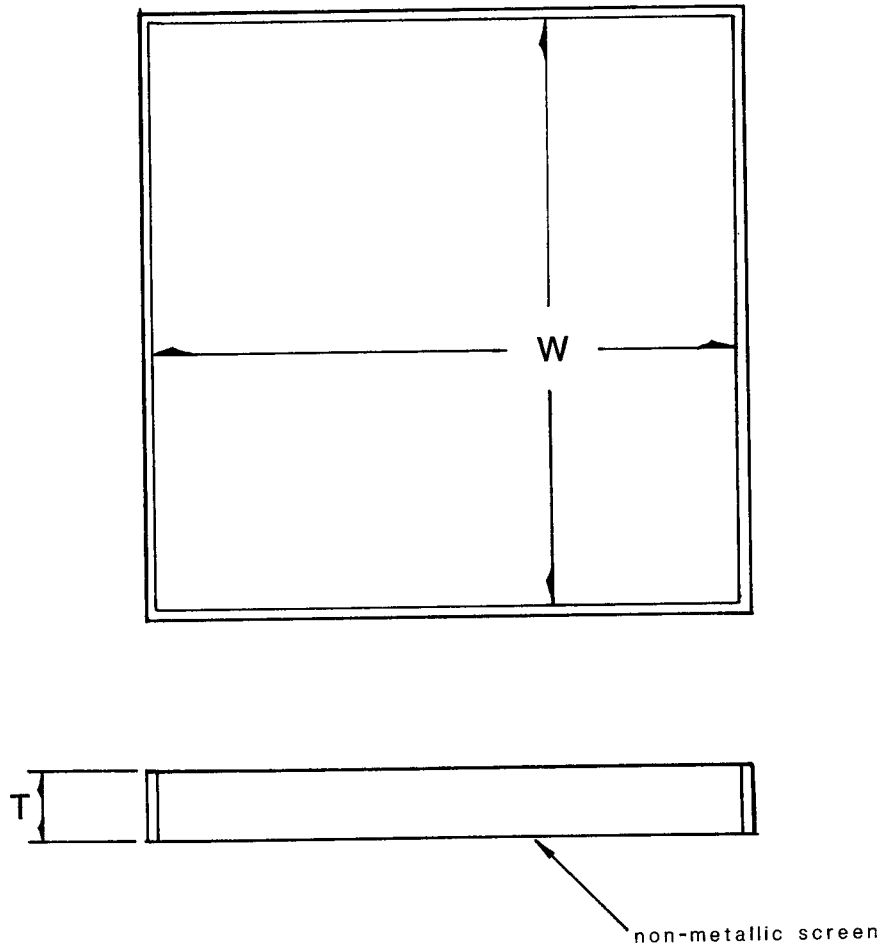

NOTE 1—Dimensions to match thermal test apparatus.

FIG. 1 Rigid Test Frame

test conditions. Some existing test apparatus have been designed to provide measurements over a range of mean temperatures from -20 to 55°C (-4 to 131°F) and for a wider range of temperature differences.

5.1.4 *Humidity*—The absolute humidity within the test apparatus shall be maintained low enough to prevent condensation within the specimen or on the cold plate(s). A maximum 9°C (48°F) dew point is consistent with the recommended material conditioning levels.

5.1.5 *Orientation and Direction of Heat Flow*—The thermal test apparatus shall be capable of testing horizontal specimens with heat flow-up. This orientation represents the most adverse heat flow condition for testing between two solid boundaries.

5.1.6 *Thermal Test Specimen Frame*—The test frame shall be sized to match the test apparatus and shall be made of materials having low thermal conductivity (<0.12 W/m K) and minimum thickness. A thin, thermally insignificant, screen or membrane is stretched across the bottom to support the material. Frames have fixed rigid sides or fold-down, collapsible, or compressible sides (see Fig. 1 and Fig. 2).

5.2 *Specimen Preparation Equipment:*

5.2.1 *Blowing Machine*—A blowing apparatus is required when pneumatically applied specimens are to be tested. Choose the combination of hopper, blower, and hose size and

length that is representative of common use for the application of the material to be tested. The following machine specifications have been developed for use with mineral wool and cellulosic materials.

5.2.1.1 *Mineral Fiber Insulations:*

(1) *Blowing Machine*—A commercial blowing machine with a design capacity for delivering the subject material at a rate between 4 and 15 kg (9 to 33 lb)/min.

(2) *Blowing Hose*—The machine shall utilize 46 m (150 ft) of typical 75 to 100 mm (3 to 4 in.) diameter flexible, internally corrugated blowing hose. At least 30 m (100 ft) of the hose shall be elevated between 3 and 6 m (10 and 20 ft) above the blowing machine to simulate a typical installation configuration. The hose shall have no more than eight 90° bends and all bends shall be greater than 1.2-m (4-ft) radius. Before each sample preparation session, examine the hose for material remaining from previous blows. Dislodge any remaining material by mechanically agitating the hose when the machine is running. Repeat as necessary to maintain a clean hose for each specimen.

NOTE 3—In case of dispute, for mineral fiber insulations a 75 mm (3 in.) hose shall be used to prepare the specimens.

5.2.1.2 *Cellulosic Insulations:*

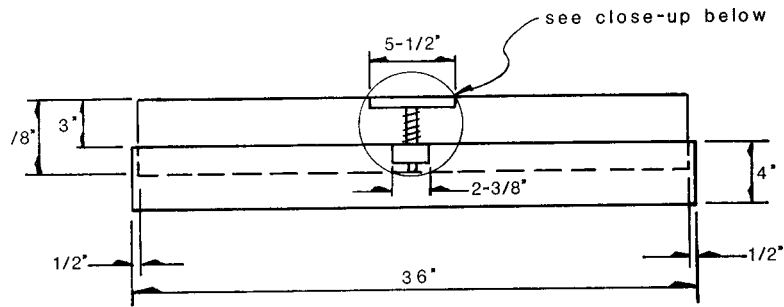

FRONT VIEW

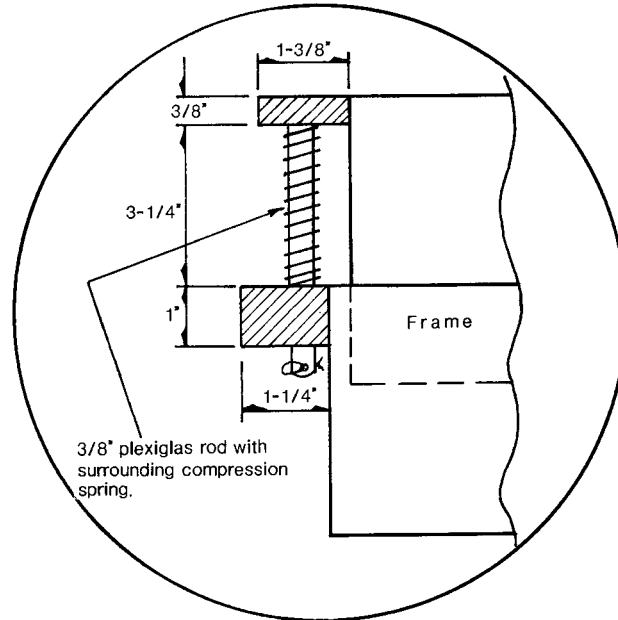

SIDE VIEW DETAIL

FIG. 2 Collapsible Test Frame (an Example)

(1) *Blowing Machine*—Use commercial blowing equipment designed for cellulosic material, that is, hopper, blower, and 30 m (100 ft) of typical 50 to 75 mm (2 to 3 in.) diameter hose.

(2) *Settled Density Catch Containers*—Containers shall be sized to match the test frames and shall be made of plywood or similar materials. A thin sheet of plywood attached across the bottom supports the insulation. Frames shall have fixed sides.

NOTE 4—In case of dispute, for cellulosic insulations a 51 mm (2 in.) hose shall be used to prepare the specimens

5.2.2 *Test Area Specimen Cutter*—A means for isolating the material within the metering area is required for the density determination. The isolated region shall have an area and shape identical to the metering area. Fig. 3 provides an example of a die cutter used for this purpose. The use of a compression plate to compress an area larger than the metering area, prior to metering area material removal is recommended. The compression plate shall extend at least 75 mm (3 in.) beyond the metering area boundary.

5.2.3 *Weighing Devices*—A device is required to weigh the test area material after the thermal test is complete. This device shall determine the test area weight to within 0.5 %. A second

device is required during sample preparation and conditioning to determine the sample plus frame weight. This device shall determine the combined weight to within 0.5 %.

5.2.4 *Conditioning Room*—An enclosure held at near constant temperature and humidity is required to stabilize the materials or products prior to testing. The conditions are generally given in product specifications or in other appropriate documents. In the absence of specific directions, conditioning shall be carried out in an atmosphere of $23 \pm 2^\circ\text{C}$ ($75 \pm 4^\circ\text{F}$) and a relative humidity not greater than 45 % (see 5.1.4).

5.2.5 *Specimen Support Sheet*—A stiff cardboard or equivalent sheet to be used to support the specimen during preparation, conditioning, and transport.

5.2.6 *Specimen Preparation Room*—A semi-enclosed area where the test material is blown into the specimen frame is required. This enclosure protects the blowing operation from wind or strong air currents. The room size shall not influence the blowing stream from the hose. Minimum room dimensions of 3 by 3 by 2.5 m (10 by 10 by 8 ft) are generally adequate for this purpose. Experience has shown that, to obtain uniform specimens, it is necessary to blow an area greater than the

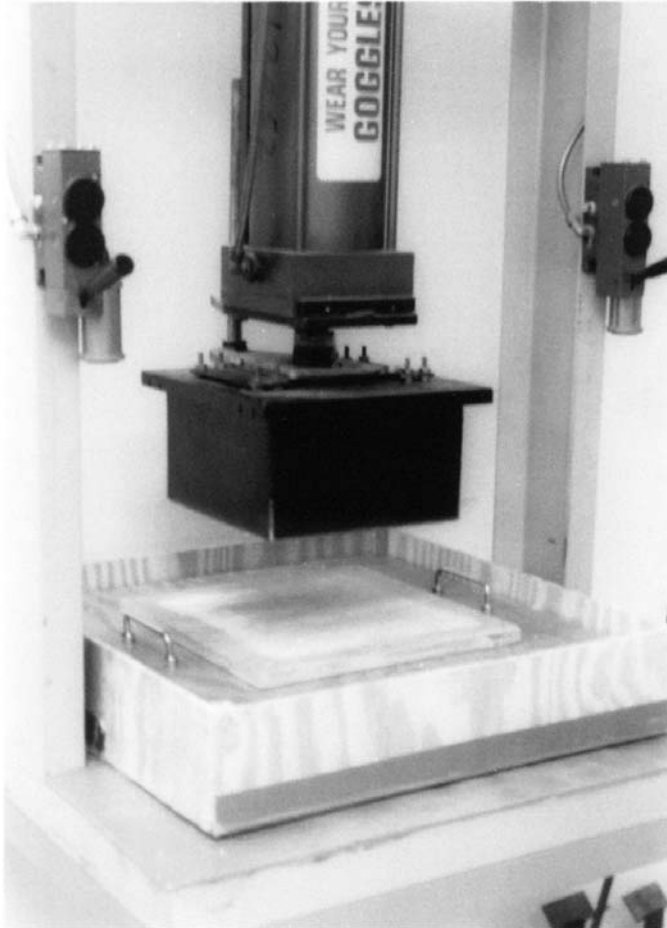

Note 1—Use of a pressure plate to compress a loose-fill specimen prior to cutting the metering area.

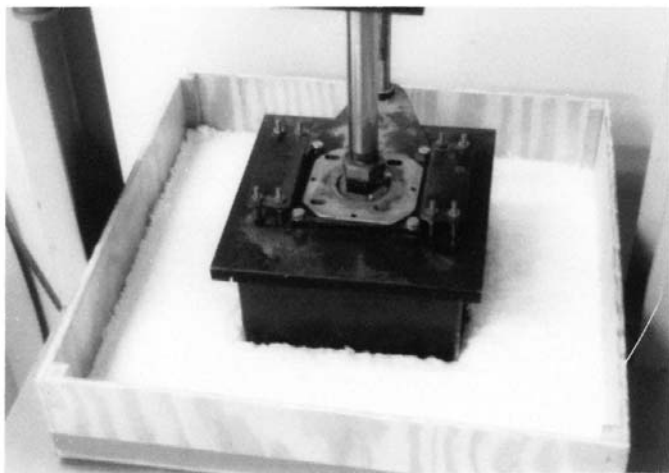

Note 2—Use of a hydraulic die cutter to cut the metering area. Note the compressed specimen after using the pressure plate.

FIG. 3 Test Area Cutter

dimensions of the specimen frame. The recommended area to be covered is at least 2.5 times the minimum test frame dimension.

6. Sampling

6.1 Sampling plans given in the material specifications, regulations, or other appropriate documents shall be followed when applicable. In the absence of such directions, material from at least two randomly chosen packages shall be combined in equal portions (weight) and placed in the blowing machine so as to combine materials as uniformly as practicable. Alternatively, multiple tests are performed where each specimen is made from a single package.

6.2 The insulation material shall be preconditioned at laboratory conditions (see 5.2.4) prior to the specimen blowing, if necessary, to remove excess moisture added during the manufacturing process. Preconditioning of materials not only ensures controlled blowing conditions but reduces the time required to condition the prepared specimen prior to thermal testing. For cellulosic materials, the preconditioning guideline is defined in Specification C 739.

7. Specimen Preparation

7.1 Pneumatic Application—General Materials:

7.1.1 The procedure described in this section is intended for products which are normally installed pneumatically which do not exhibit settling under normal installed conditions. Use Paragraph 7.2 for pneumatically installed products where the specimen preparation is modified to accommodate a correction for settling after installation.

NOTE 5—For commonly available loose-fill insulations, state and federal energy codes, ASTM material specifications, and the Federal Trade Commission have identified those materials that apply a correction for settling when determining thermal performance. It is beyond the scope of this practice to outline the procedures for this determination.

7.1.2 The specimen preparation room shall be clean and free of old insulation prior to the start of specimen preparation.

NOTE 6—Many factors influence the characteristics of the blown insulation. These include blowing rate, machine adjustments, the size and length of the hose, and the angle and dimensions of the hose outlet in relation to the test frame. Trained operators are required to duplicate field-installed conditioning. Some users of this method have constructed a support structure that holds the hose end at the proper orientation. This removes some of the operator dependency during the blowing operation.

NOTE 7—For ease of specimen preparation, the specimen shall be blown close to the desired test density. Operators have the option to establish a target weight of insulation required to fill the test frame as a control during the specimen preparation process. By placing the specimen frame and support sheet on a scale in the specimen preparation room while blowing occurs, it is possible to fill the container with the mass of the insulation targeted for the test. Another option is to eliminate these extra steps. The reported test density, however, is obtained from the metering area density measurement conducted after the thermal test.

7.1.3 If the specimen is to be blown to a predetermined density, calculate the target weight of insulation required to fill the test frame to the target thickness and density. If the intent is to test the material at whatever density is blown, then this calculation is not required.

7.1.4 Assemble the blowing machine, hose, and hose length combination as appropriate for the material being prepared (see recommendations in 5.2.1.1).

7.1.5 Set the blowing machine adjustments and select the feed rates in accordance with the insulation manufacturer's recommendations. If the insulation manufacturer does not provide this information, consult the machine manufacturer for recommended settings. Record the machine settings used.

7.1.6 Place at least two packages (see 6.1) of the insulation material into the blowing machine hopper. If the hopper is too small to hold two packages of material, fill the hopper to capacity with equal portions of material from two packages.

7.1.7 Place the thermal specimen holder on the specimen support sheet in the center of the specimen preparation area (see Note 7).

7.1.8 Turn on the blowing machine with the hose outlet directed away from the test specimen frame. Do not blow the thermal test specimen until a steady flow of insulation material has been achieved.

7.1.9 Once steady flow is achieved, (approximately 30 to 45 s), direct the hose outlet toward the test specimen frame. The hose outlet shall be horizontal and at a height above the test specimen frame of no less than 0.9 m and no greater than 1.2 m (3 to 4 ft). This height is measured from the centerline of the hose opening.

7.1.10 The end of the loose-fill trajectory falls beyond the test specimen frame at the start of the blow. The operator shall slowly step back, allowing the end of the trajectory to fall into the specimen frame. While continuing to back up, the operator slowly changes the direction of the hose approximately $\pm 45^\circ$ in a horizontal plane to uniformly fill the test specimen frame. The operator continues to make passes back and forth until the specimen frame is filled to approximately one half of the target thickness.

7.1.11 When the test specimen frame is approximately one half full, point the hose away from the test frame and stop the blowing machine. Remove all excess insulation from around the test frame, being careful not to disturb the insulation inside. Carefully rotate the test frame and support sheet 180° from their original position. Do not jar the frame or cause any unnecessary settling of the insulation. During handling of the blown specimen, keep the support sheet firmly against the bottom of the specimen frame.

NOTE 8—For some insulation materials, it is not necessary to rotate the specimen frame during blowing in order to prepare a uniform specimen. However, in case of dispute, the specimen preparation procedure listed, herein, shall be followed.

7.1.12 Restart the blowing machine, establish flow as in 7.1.8, and continue to fill the test specimen frame.

7.1.13 Continue blowing the material into the test frame until it is uniformly full and there is a slight excess above the target test thickness. Do not exceed 20 % excess thickness while blowing. For specimen preparation controlled by weight, the control must be a maximum of 110 % of the target weight in addition to the thickness limit stated in 7.1.13.

NOTE 9—If the intent is to test at a specific density and the specimen exceeds the upper mass limit without reaching the target thickness or exceeds the upper thickness limit without meeting the target mass, a new specimen must be prepared.

NOTE 10—Care shall be observed when handling or moving the filled specimen frame so as not to disturb the test specimen any more than is

absolutely necessary. Any vibration or impact changes the pack structure of the blown sample and changes its thermal properties.

7.1.14 Remove the surrounding excess material from the area of the test frame. Move the specimen frame and support sheet to a flat level table.

7.1.15 Remove excess material to reach a level thickness that is no greater than 115 % of target test thickness. Do not disturb the remaining material, preserving it in the as-blown condition.

7.1.16 Move the specimen frame and its accompanying support sheet to the specimen conditioning room.

7.1.17 Condition the specimen and frame for sufficient time to reach constant weight (less than 1.0 % weight change in 24 h).

7.2 *Pneumatic Application—Settled Density Method:*

7.2.1 This method is intended for pneumatically installed products where the specimen preparation is modified to accommodate a correction for settling after installation.

NOTE 11—Although this section is specific to cellulosic insulations, the principles outlined are used for other insulations requiring correction for settled density, providing that the appropriate blowing equipment and settling simulation method (see 7.2.13) is used. Reference shall be made to the appropriate material specification to make this determination.

7.2.2 Assemble the blowing machine, hose, and hose length combination as appropriate for the insulation material being prepared. (See recommendations in 5.2.1.2.)

7.2.3 With the blower turned off, turn on the agitator in the hopper and load just enough insulation to cover the agitator.

7.2.4 Allow the agitator to run until the material appears to be thoroughly broken apart.

7.2.5 Hold the hose so the outlet is horizontal and at a height above the test specimen frame of no less than 0.9 m and no greater than 1.2 m (3 to 4 ft). This height is measured from the centerline of the hose opening. Turn on the blower and adjust the air slide on the inlet side of the blower until excessive dust begins to appear. Back off air slightly and record the setting. During this process, manually add insulation to the hopper to keep the agitator in the hopper covered.

7.2.6 Turn off the equipment and clean the specimen preparation room.

7.2.7 Place the thermal test frame on top of the support sheet in the center of the specimen preparation room and rotate the assembly 45° so that the diagonal of the specimen is in line with the blowing direction. Position four additional catch containers around the four sides on the test frame so as to create an "x" pattern.

7.2.8 Turn on the agitator and add insulation to the hopper until the agitator is covered.

7.2.9 Position the hose end as in 7.2.5 and, using the same air settings for the blower, turn on the blower. Once uniform flow is established, begin filling the test boxes at the rear of the specimen preparation room as follows. The end of the loose-fill trajectory falls beyond the test specimen frame at the start of the blow. The operator shall slowly step back, allowing the end of the trajectory to fall into the specimen frame and catch containers. While continuing to back up, the operator slowly changes the direction of the hose approximately $\pm 45^\circ$ in a horizontal plane to uniformly fill the test specimen frame. The

operator continues to make passes back and forth until the specimen frame is filled to the target thickness. The agitator shall be covered at all times during the blowing process.

7.2.10 Fill the containers to a depth even with the level of the catch containers. Do not overfill above the side extensions.

7.2.11 When the catch containers and the test frame have been filled, gently screed the insulation flush with the top edge of the extensions. Avoid any vibration, compression, or compaction that might alter the density.

7.2.12 Weigh the catch containers and determine the average blown density using the net weight contained in each.

7.2.13 Take one or more of the four catch containers and determine the design density of the insulation using the blower cyclone shaker (BCS) test in accordance with Specification **C 739**; skip the specimen preparation steps listed which use the commercial blower and hopper. (See **Note 9**.)

7.2.14 Carefully remove the surrounding excess material from the area of the test frame. Move the test box and its accompanying support sheet to the specimen conditioning room.

7.2.15 Condition the specimen and frame for sufficient time to reach constant weight, shown to be within 1.0 % weight change in 24 h.

7.2.16 Using the settled density value (7.2.13), determine the amount of material required to fill the test frame at the settled density for the desired test thickness. After conditioning and while still in the conditioning environment, uniformly remove excess material to reach the targeted weight. Do not disturb the remaining material, preserving it in the as-blown condition.

7.3 Cellulosic Insulation—Alternate Procedure for Pneumatically Blown Specimens.

7.3.1 **Background**—This procedure is an alternate procedure to 7.2 for cellulosic materials that meet the material characteristics required. This procedure for test specimen preparation has been found to provide representative specimens for cellulosic insulation that are pneumatically blown. This procedure is not applicable for cellulose materials that are wet applied or otherwise chemically altered during the insulation process. Use of this procedure provides a method of sample preparation that does not require that a blowing machine be used to place the insulation in the test box but does require that the sample material be processed through a blowing machine to simulate the material preparation occurring during the blowing process. For cases of dispute, however, the blown sample preparation technique of 7.2 shall be considered correct.

7.3.2 Place the cellulosic insulation into a lightweight conditioning box measuring approximately 600 by 350 by 300 mm. Break up the large clumps of insulation by hand prior to conditioning. Note that sufficient material shall be conditioned to meet the requirements of the thermal and test density tests of 7.3.5 with some allowance for handling losses.

7.3.3 Condition the cellulosic material as described in Conditioning, under Design Density in Specification **C 739**, at $21 \pm 2^\circ\text{C}$ and $50 \pm 5\%$ relative humidity until equilibrium (constant weight) is achieved.

7.3.4 Process the conditioned insulation into a collection box using a blowing machine capable of producing insulation to the desired blown density. One example of a commercial machine is described in 7.2.2.

7.3.5 Determine the test density for the insulation of 7.3.4, using the procedure outlined in Section 8 of Specification **C 739**.

NOTE 12—The thin walled metering area frame, required in 7.3.7, is constructed of thin sheet metal (approximately 0.51 to 0.76 mm) or other similar material and shall be designed so that it can be easily removed after the entire test frame is filled with insulation. The partition's inside dimensions shall be approximately equal ($-0 / +1\%$) to the test area dimensions.

NOTE 13—In addition to the collapsible sides specified in 5.1.6, a removable side ring for the test box perimeter is used to restrain the insulation during insulation installation. This ring is removed prior to testing.

7.3.6 Using the test density determined from 7.3.5 and the test thickness, determine the mass of material required to fill the metering area frame and the remaining specimen area of the thermal test frame as follows:

$$\text{Test Area Mass: } M_m = D_s \times A_m \times L \quad (1)$$

where:

M_m = mass of material contained in the metering area frame, kg,

D_s = test density of insulation determined in 7.3.5, kg/m^3 ,

A_m = area of the metering area frame, m^2 , and

L = test thickness, m.

$$\text{Remaining Area Mass: } M_r = D_s \times (A_f - A_m) \times L \quad (2)$$

where:

M_r = mass of material contained in the remaining area, kg, and

A_f = total test frame area from inside dimensions, m^2 .

7.3.7 Position the metering area frame in the test box with the frame walls centered and in line with the test area perimeter.

7.3.8 Place the test box assembly with metering area frame installed on a scale that has the capability of determining the mass of the entire filled box to the nearest 0.5 % of the net metering area mass of the cellulose insulation.

7.3.9 Determine the tare mass of the test box assembly, metering area frame, and any support material used to the nearest 0.1 g.

7.3.10 Place the conditioned material, by hand, into the test area demarcated by the metering area frame, until it contains the proper mass of material, M_m , as determined in 7.3.6. Use hand placement to ensure uniform coverage and thickness for the insulation.

NOTE 14—A small box or scoop has been found satisfactory for placing the insulation into the test box.

7.3.11 Place the conditioned material, by hand, into the surrounding area demarcated by the metering area frame, until it contains the proper mass of material, M_r , as determined in 7.3.6.

7.3.12 With a device such as a hair pick, level and smooth the surface of the entire test box.

7.3.13 Carefully, without disturbing the insulation, remove the metering area frame.

7.3.14 Shake or gently vibrate with a horizontal motion, the test box containing the insulation, until the insulation thickness is approximately 6.4 mm (0.25 in.) thicker than the desired test thickness.

7.3.15 Place the test box into the test chamber and conduct the test per Section 8.

7.3.16 If this alternative procedure for cellulosic sample preparation is used for the preparation of the test specimen, the density determination of 8.9 and 9.1 is unnecessary and is omitted. In that case, the density recorded for the test is the test density determined in 7.3.5.

7.3.17 The report of the test results shall indicate the sample preparation method used.

7.4 *Pouring Application*—For products intended to be poured in place:

7.4.1 Calculate the weight of insulation required to fill the frame to the design thickness and density.

7.4.2 Pour an amount of insulation slightly in excess of the amount calculated in 7.3.1 into a preweighed test frame following pouring instructions given in appropriate specifications. The sample box shall be nearly level and uniformly full.

7.4.3 Condition the specimen and frame for sufficient time to reach constant weight, shown to be within 1.0 % weight change in 24 h.

7.4.4 After conditioning and while still in the conditioning environment, carefully remove excess material to reach the targeted weight calculated in 7.3.1, being careful not to disturb the remaining material.

8. Test Procedure

8.1 Carefully move the thermal test specimen frame, including the support sheet, to a level area at table height. Using a pencil or piece of stiff wire, level the top surface of the specimen taking care not to disturb the subsurface material.

8.2 For materials to be tested at their settled density, omit 8.3 and use the targeted test thickness for the test.

8.3 Determine the specimen thickness at the locations shown in Fig. 4 using a pin gage apparatus (Test Methods C 167). The technique used for the pin gage measurement for loose-fill insulation is as follows:

8.3.1 Insert the pin at a selected location, in a vertical orientation, until the pin contacts the solid base surface.

NOTE 15—Close attention to the insertion and withdrawal of the pin probe shall be made so as not to disturb the material or create void areas. Keep the probe vertical and do not move it sideways.

8.3.2 While holding the pin in the vertical orientation, slowly lower the disk until it lightly contacts the specimen surface. Proper contact for determining the rough surface height is defined as that level at which the disk surface corresponds to the location of the mean of the surface peaks and valleys in the area outlined by the disk perimeter.

8.3.3 While holding the disk at its position in 8.3.2, gently withdraw the pin from the insulation and determine and record the distance from the disk's surface to the end of the pin.

8.3.4 Average the 4 readings of 8.3.3. Report and record that value as the average contact thickness.

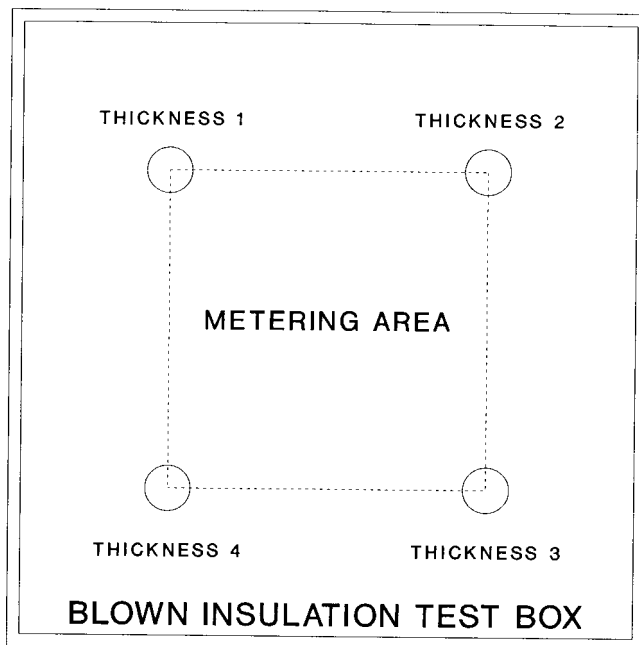

FIG. 4 Recommended Contact Thickness Measurement Locations

8.4 Transfer the conditioned specimen and frame in its horizontal position to the thermal test apparatus, being careful not to disturb the specimen.

8.5 Determine the test thickness using one of the following:

8.5.1 For insulations to be tested at settled density, the test thickness is the target thickness used to calculate the specimen weight.

8.5.2 For single thickness tests at the as-blown density, calculate the test thickness for the specimen to be 95 % of the contact thickness (8.3). This thickness ensures good thermal plate contact and minimizes specimen compression.

$$\text{Test Thickness} = \text{Contact Thickness (see 8.3)} \times 0.95 \quad (3)$$

8.5.3 Multiple thickness testing is used if a thermal resistivity value is desired at a targeted density such as that determined from the coverage chart. This procedure is similar to that outlined in Guide C 653. For testing loose-fill materials, the three test points to be used are at 100, 92.5, and 85 % of contact thickness. As with Guide C 653, the target density must reside within the range of tested values.

8.5.4 Excessive compression of a blown insulation specimen during testing changes the morphology of the insulation pack, which in turn, alters its thermal resistance behavior. Therefore, to avoid excessive compression errors in the tested result, no test that claims conformance to this practice shall be conducted at a test thickness less than 85 percent of the contact thickness. (See Note 16.)

8.6 Close the test apparatus until the test thickness (see 8.5) is achieved. If multiple-point testing is selected, order the tests from the greatest thickness to the smallest.

NOTE 16—The measured thermal properties are very dependent upon blowing conditions and blown density. This phenomenon is discussed in

Note 6 and the literature (1), (2), (3).⁴ For some insulations, compressing the material from a light, blown density to a significantly higher test density can give higher resistivity values than for material blown close to the desired test density. Thus, compression of the thermal specimens beyond the 85 % limit is not permitted. To obtain thermal resistivity data for a range of densities, separate tests shall be made with different blowing conditions. Such tests must be carefully designed to ensure that the material is being characterized properly. For research purposes, the thermal resistivity/density data are needed at a given blowing condition. A collapsible frame is used and successive tests are then made at different thicknesses for a single specimen.

8.7 Conduct the test(s) in accordance with all requirements of the appropriate thermal test procedure. Unless otherwise specified, the test shall be conducted at a mean temperature of 23.9°C (75°F) and a fixed temperature difference in the range from 20 to 28°C (36 to 50°F).

NOTE 17—High-moisture contents result in unacceptably longtime requirements for the insulation specimen to reach thermal equilibrium in the testing apparatus. For the test conditions shown in 8.7, cellulosic materials require moisture contents below 10 % of dry (equilibrium at 100°C [212°F]) weight to reduce the testing time to a reasonable level.

8.8 If multiple thickness measurements are to be made, repeat 8.6 and 8.7 for the remaining thicknesses.

8.9 After the thermal test(s) are complete, remove the specimen and frame from the apparatus and place on a plane level surface. Place the test area specimen cutter (5.2.2) or other suitable means to isolate the metering area material within the specimen frame at the center of the test area of the specimen. Cut, remove, and weigh, to the nearest 0.5 %, the insulation within the metering area for the density determination.

9. Calculation

9.1 **Density**—Calculate the test density(s) from the metering area, the weight of the insulation in the cutter (from 8.9) and the test thickness (from 8.6) according to the following formula:

$$\text{Test Density} = \frac{\text{Metering Area Weight}}{\text{Thickness Area}} \quad (4)$$

9.2 Thermal Resistivity:

9.2.1 Calculate the thermal resistance at the test thickness following the procedures given in the test method.

9.2.2 Calculate the thermal resistivity and thermal conductivity of the test density using Eq 5 and Eq 6.

$$\text{Thermal Resistivity} = \frac{\text{Thermal Resistance}}{\text{Test Thickness}} \quad (5)$$

$$\text{Thermal Conductivity} = \frac{\text{Test Thickness}}{\text{Thermal Resistance}} \quad (6)$$

9.2.3 When multiple thickness testing is used, determine the thermal resistivity and thermal conductivity of the insulation at the targeted density using the data stated in 8.7-8.9, and the procedure outlined in Guide C 653.

10. Report

10.1 Report the following information:

10.1.1 References to applicable specifications and test methods,

10.1.2 The name, address, and other identification of the test laboratory and the date of the report,

10.1.3 The name and other identification of the material or product tested and the date of the test,

10.1.4 The source of the material or product, the date obtained, and the method of sampling,

10.1.5 The method and details of the specimen preparation including blowing machine, machine settings used, and any preconditioning,

10.1.6 The method and conditions of specimen conditioning,

10.1.7 The ASTM thermal test method used for the test results reported,

10.1.8 The dimensions of the thermal apparatus, the orientation of the specimen, and the direction of heat flow,

10.1.9 The mean specimen temperature, and test temperature difference,

10.1.10 The test thickness(s) and the density(s) of the specimen.

10.1.11 The specimen thermal resistance and the thermal resistivity for each test density,

10.1.12 An estimate of the precision and accuracy of the test results (see Section 11),

10.1.13 Method of determining settled density, if applicable, and

10.1.14 Any other pertinent observations or remarks.

NOTE 18—Unless otherwise specified, all values shall be reported in both SI and inch-pound units.

11. Precision and Bias

11.1 The precision and bias of the test results obtained using this practice include the effects of: (1) adherence to the test procedures, (2) performance characteristics of the test apparatus, (3) variability of the material or product, and (4) sampling and specimen preparation. The influence of the material or product variability and the test imprecision are interactive. The characteristics of the specimen affect the test accuracy while characteristics of the test apparatus (for example, the test area size) affect the apparent variability of the material or product. Larger platen areas are expected to provide better accuracy when specimens are thick and variable in character.

11.2 As a minimum requirement for this practice, estimates shall be made of the precision and bias of the test apparatus used. Guidance on estimates of these values is given in Test Methods C 177, C 518, C 1114, and C 1363.

11.3 Estimates of the precision and bias of the results, as representative of the materials or product, must be based on sufficient experiments to determine the variability and the effect of sampling and specimen preparation upon it.

11.4 The most comprehensive estimate of precision and bias of Practice C 687 – 91 was based on an interlaboratory comparison of nine participating laboratories. This test program used four common loose-fill materials and a glass fiber blanket. (4) The results of this comparison indicate that the measurement capability of the participants is characterized by an imprecision of 2.8 %, with negligible bias of the mean, when

⁴ The boldface numbers in parentheses refer to the list of references at the end of this practice.

measuring the glass fiber blanket. The measurements on the four loose-fill materials are characterized by an imprecision ranging from 5.0 to 10.5 %. (See **Note 19**.)

11.5 The results of this test sequence demonstrated significant improvement in the test results over the interlaboratory comparison for the previous, C687 – 85, version of this test method. **(5)** The improvement in the test result imprecision is a direct result of the improved sample preparation procedures.

NOTE 19—For this discussion, the imprecision is defined as two times the standard deviation of the percentage difference between the test points and the reference curve.

12. Keywords

12.1 insulation; loose-fill; thermal resistance

REFERENCES

- (1)** Bomberg and Solvason, “Building Research Note 167,” NRC, Canada, 1980.
- (2)** McCaa, D., “Use of Heat Flow Meter Apparatus for Testing Loose-Fills,” *ASTM STP 879*, ASTM, 1985, pp. 154–160.
- (3)** NAHBRF Report, “Thermal Conductivity versus Density as a Function of Blown Thickness for Pneumatically Applied Mineral Fiber Insulations,” NAHB, October 1983.
- (4)** McCaa, D. J., Smith, D. R., et al., “Interlaboratory Comparison of the Apparent Thermal Conductivity of a Fibrous Batt and Four Loose-Fill Insulations,” *ASTM STP 1116*, ASTM, October 1991, pp. 534–557.
- (5)** Adams, R. D., and Hust, J. G., “An Interlaboratory Comparison of the ASTM C687 Loose-Fill Insulation Test Procedure,” *ASTM STP 1030*, ASTM, November 1989, pp. 263–289.

ASTM International takes no position respecting the validity of any patent rights asserted in connection with any item mentioned in this standard. Users of this standard are expressly advised that determination of the validity of any such patent rights, and the risk of infringement of such rights, are entirely their own responsibility.

This standard is subject to revision at any time by the responsible technical committee and must be reviewed every five years and if not revised, either reapproved or withdrawn. Your comments are invited either for revision of this standard or for additional standards and should be addressed to ASTM International Headquarters. Your comments will receive careful consideration at a meeting of the responsible technical committee, which you may attend. If you feel that your comments have not received a fair hearing you should make your views known to the ASTM Committee on Standards, at the address shown below.

This standard is copyrighted by ASTM International, 100 Barr Harbor Drive, PO Box C700, West Conshohocken, PA 19428-2959, United States. Individual reprints (single or multiple copies) of this standard may be obtained by contacting ASTM at the above address or at 610-832-9585 (phone), 610-832-9555 (fax), or service@astm.org (e-mail); or through the ASTM website (www.astm.org).