



Standard Test Method for Compressive Strength of Carbon and Graphite¹

This standard is issued under the fixed designation C 695; the number immediately following the designation indicates the year of original adoption or, in the case of revision, the year of last revision. A number in parentheses indicates the year of last reapproval. A superscript epsilon (ϵ) indicates an editorial change since the last revision or reapproval.

This standard has been approved for use by agencies of the Department of Defense.

1. Scope

1.1 This test method covers the determination of the compressive strength of carbon and graphite at room temperature.

1.2 *This standard does not purport to address all of the safety concerns, if any, associated with its use. It is the responsibility of the user of this standard to establish appropriate safety and health practices and determine the applicability of regulatory limitations prior to use.*

2. Referenced Documents

2.1 ASTM Standards:²

C 709 Terminology Relating to Manufactured Carbon and Graphite

E 4 Practices for Force Verification of Testing Machines

E 177 Practice for Use of the Terms Precision and Bias in ASTM Test Methods

E 691 Practice for Conducting an Interlaboratory Study to Determine the Precision of a Test Method

3. Terminology

3.1 *Definitions: Definitions*—For definitions of terms relating to manufactured carbon and graphite, see Terminology **C 709**.

4. Significance and Use

4.1 Carbon and graphite can usually support higher loads in compression than in any other mode of stress. This test, therefore, provides a measure of the maximum load-bearing capability of carbon and graphite objects.

5. Apparatus

5.1 *Test Machine*, conforming to Practice **E 4** and to the requirements for speed of testing prescribed in Section 8 of this test method.

5.2 *Spherical Bearing Blocks* attached to the upper or lower head of the machine in such a manner that the spherical surfaces are in full contact when not loaded. The center of curvature of the spherical surface shall lie on the surface that contacts the specimen and on the machine axis. The spherical surfaces shall be well-lubricated. The radius of the spherical surface shall be equal to or greater than the radius of the test specimen.

5.3 *Steel Contact Blocks* may be used above or below the specimen, or both, to protect fixture and test machine surfaces from damage, as illustrated in **Fig. 1** and **Fig. 2**. Contact block surfaces shall be plane and parallel to within 0.0005 in./in. (0.0005 mm/mm).

5.4 All load-bearing machine and fixture surfaces shall have a minimum hardness of 45 HRC and surface finish of 16 μin . (0.4 μm) rms maximum. Surfaces in contact with the specimen shall be flat to less than 0.0005 in./in. (0.0005 mm/mm).

5.5 Examples of arrangements of the load train are shown schematically in **Fig. 1** and **Fig. 2**.

6. Sampling

6.1 Samples may be taken from locations and orientations that satisfy the objectives of the test.

7. Test Specimen

7.1 The test specimen shall be a right cylinder with ends machined to yield planar and parallel faces. These faces shall be perpendicular to the cylindrical surface to within 0.001 in./in. (0.001 mm/mm) of diameter total indicator reading. All surfaces shall have a surface finish visually comparable to 32 μin . (0.8 μm) rms or better. Reasonable care should be exercised to assure that all edges are sharp and without chips or other flaws.

7.2 The diameter of the test specimen shall be greater than ten times the maximum particle size of the carbon or graphite. The ratio of height to diameter may vary between 1.9 and 2.1. The recommended minimum test specimen size is $\frac{3}{8}$ in. (9.5 mm) diameter by $\frac{3}{4}$ in. (19 mm) high.

¹ This test method is under the jurisdiction of ASTM Committee D02 on Petroleum Products and Lubricants and is the direct responsibility of Subcommittee D02.F0 on Manufactured Carbon and Graphite Products.

Current edition approved June 1, 2005. Published August 2005. Originally approved in 1971. Last previous edition approved in 2000 as C 695–91(2000).

² For referenced ASTM standards, visit the ASTM website, www.astm.org, or contact ASTM Customer Service at service@astm.org. For *Annual Book of ASTM Standards* volume information, refer to the standard's Document Summary page on the ASTM website.

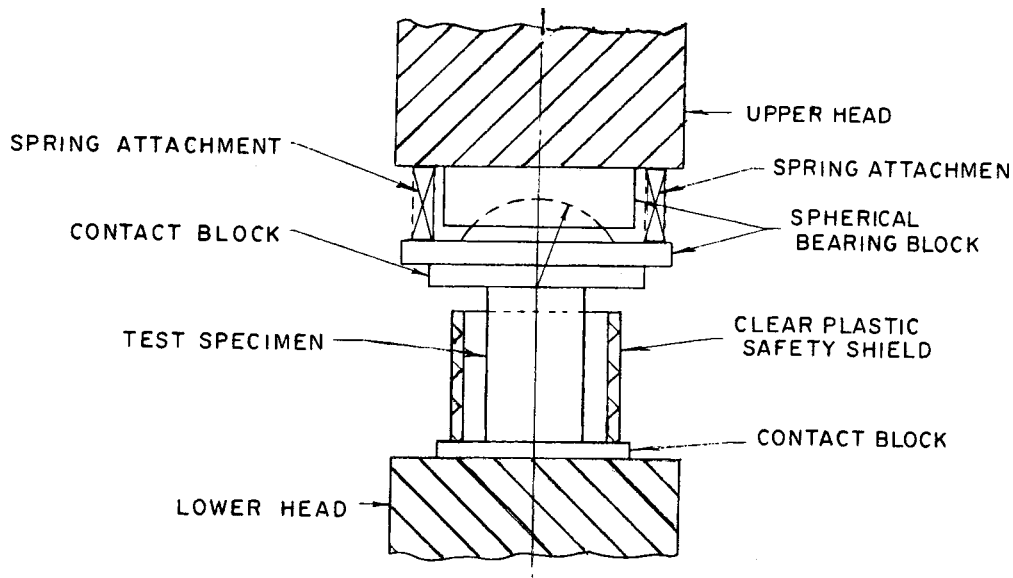

FIG. 1 Elements of Compressive Strength Load Train

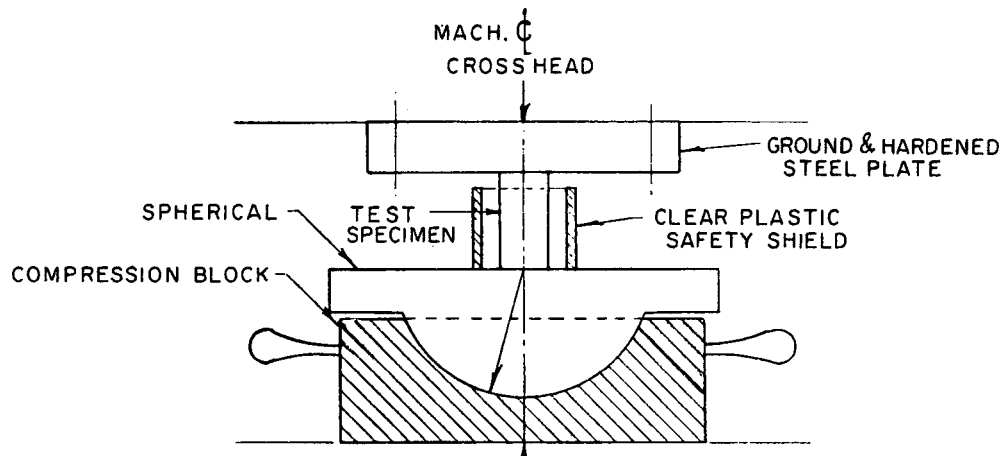

FIG. 2 Compressive Test Arrangement with Spherical Blocks on Bottom

8. Procedure

8.1 Center the specimen in the machine between the contact surfaces. The deviation of the specimen axis from the machine axis shall be less than 5 % of the specimen diameter. Centering can be assisted by appropriate circles marked on the contact surfaces.

8.2 Place an appropriate guard around the specimen to deflect flying fragments at failure.

8.3 Apply the load continuously, at a constant rate of crosshead or platen movement, and without shock until ultimate failure. Choose the rate of movement so that average rupture time is greater than 30 s.

8.4 If the test machine is equipped with a load or strain pacing device, a constant load or strain rate may be used.

9. Calculation

9.1 Calculate the compressive strength of each specimen as follows:

$$C = W/A$$

where:

C = compressive strength of specimen, psi (or MPa),
 W = total load on the specimen at failure, lbf (or N), and
 A = calculated area of the gage section of the specimen, in.²(or mm²).

10. Report

10.1 The report shall include the following:

- 10.1.1 Type of testing machine, hydraulic or screw,
- 10.1.2 Type and size of contact blocks,
- 10.1.3 General description of material being tested,
- 10.1.4 Dimensions, location, and orientation of specimens,
- 10.1.5 Details of specimen preparation,
- 10.1.6 Rate of crosshead or platen movement, or load rate, or strain rate,
- 10.1.7 Load at failure, failure mode, and compressive strength of each specimen, and
- 10.1.8 Mean compressive strength and standard deviation for material tested.

11. Precision and Bias³

11.1 *Precision*—The precision statements given in this section are based on the comparison of the mean strength by the Student “*t*” test and carrying out the statistical analysis of the data obtained in a round robin as recommended by Practice E 691. The round robin was carried out on two materials.

11.1.1 *Comparison of the Means*—The comparison of the means by the Student “*t*” test leads to the conclusion that the average strength values measured by each laboratory on each material can be considered statistically equal at 95 % confidence level.

11.1.2 *Repeatability (Single Instrument)*— The precision within laboratory of two single values of measured strength using Practice E 177 definition with the pooled standard deviation calculated using Practice E 691:

$$\text{Repeatability within laboratory} = 2 (S_r)_j$$

which yields a value for the materials used in the round robin of 469 psi (3.2 MPa) for one material and 522 psi (3.6 MPa) for the other. These values convert into strength percentages of ± 5 for one material and ± 2.5 for the other.

11.1.3 *Repeatability (Multi-Instrument)*— The precision between laboratories of two single values of measured strength using Practice E 177 definition with the component of variance between laboratories calculated using Practice E 691 is:

$$\text{Repeatability between laboratories} = 2 (S_L)_j$$

which yields a value for the materials used in this round robin of 347 psi (2.4 MPa) for one material and 135 psi (1 MPa) for the other. This converts into strength percentages of ± 3 for one material and ± 1 for the other.

11.2 *Bias*—No true statement on bias can be made because no reference carbon or graphite material exists.

12. Keywords

12.1 carbon; compressive strength; graphite

³ Supporting data have been filed at ASTM International Headquarters and may be obtained by requesting Research Report RR:C05-1010.

ASTM International takes no position respecting the validity of any patent rights asserted in connection with any item mentioned in this standard. Users of this standard are expressly advised that determination of the validity of any such patent rights, and the risk of infringement of such rights, are entirely their own responsibility.

This standard is subject to revision at any time by the responsible technical committee and must be reviewed every five years and if not revised, either reapproved or withdrawn. Your comments are invited either for revision of this standard or for additional standards and should be addressed to ASTM International Headquarters. Your comments will receive careful consideration at a meeting of the responsible technical committee, which you may attend. If you feel that your comments have not received a fair hearing you should make your views known to the ASTM Committee on Standards, at the address shown below.

This standard is copyrighted by ASTM International, 100 Barr Harbor Drive, PO Box C700, West Conshohocken, PA 19428-2959, United States. Individual reprints (single or multiple copies) of this standard may be obtained by contacting ASTM at the above address or at 610-832-9585 (phone), 610-832-9555 (fax), or service@astm.org (e-mail); or through the ASTM website (www.astm.org).