



Standard Test Method for Tensile Stress-Strain of Carbon and Graphite¹

This standard is issued under the fixed designation C 749; the number immediately following the designation indicates the year of original adoption or, in the case of revision, the year of last revision. A number in parentheses indicates the year of last reapproval. A superscript epsilon (ϵ) indicates an editorial change since the last revision or reapproval.

1. Scope*

1.1 This test method covers the testing of carbon and graphite in tension to obtain the tensile stress-strain behavior, to failure, from which the ultimate strength, the strain to failure, and the elastic moduli may be calculated as may be required for engineering applications. **Table 1** lists suggested sizes of specimens that can be used in the tests.

NOTE 1—The results of about 400 tests, on file at ASTM as a research report, show the ranges of materials that have been tested, the ranges of specimen configurations, and the agreement between the testers. See Section 11.

NOTE 2—For safety considerations, it is recommended that the chains be surrounded by suitable members so that at failure all parts of the load train behave predictably and do not constitute a hazard for the operator.

1.2 The values stated in inch-pound units are to be regarded as standard. The values given in parentheses are mathematical conversions to SI units that are provided for information only and are not considered standard.

1.3 *This standard does not purport to address all of the safety concerns, if any, associated with its use. It is the responsibility of the user of this standard to establish appropriate safety and health practices and determine the applicability of regulatory limitations prior to use.*

2. Referenced Documents

2.1 ASTM Standards:²

- C 565** Test Methods for Tension Testing of Carbon and Graphite Mechanical Materials
- C 709** Terminology Relating to Manufactured Carbon and Graphite
- E 4** Practices for Force Verification of Testing Machines

E 6 Terminology Relating to Methods of Mechanical Testing

E 177 Practice for Use of the Terms Precision and Bias in ASTM Test Methods

E 691 Practice for Conducting an Interlaboratory Study to Determine the Precision of a Test Method

3. Terminology

3.1 *Definitions*—The terms as related to tension testing as given in Terminology **E 6** shall be considered as applying to the terms used in this test method. See also Terminology **C 709**.

4. Summary of Test Method

4.1 A tensile specimen (**Fig. 1**) is placed within a load train assembly made up of precision chains and other machined parts (**Fig. 2**). A load is applied to the specimen provided with means of measuring strain until it is caused to fracture. This test yields the tensile strength, elastic constants, and strain to failure of carbons and graphites.

5. Significance and Use

5.1 The round robin testing on which the precision and bias for this test method have been determined employed a range of graphites (see **Table 1**) whose grain sizes were of the order of 1 mil to ¼ in. (0.0254 to 6.4 mm) and larger. This wide range of carbons and graphites can be tested with uniform gauge diameters with minimum parasitic stresses to provide quality data for use in engineering applications rather than simply for quality control. This test method can be easily adapted to elevated temperature testing of carbons and graphites without changing the specimen size or configuration by simply utilizing elevated temperature materials for the load train. This test method has been utilized for temperatures as high as 4352°F (2400°C). The design of the fixtures (**Figs. 2-9** and **Table 2**) and description of the procedures are intended to bring about, on the average, parasitic stresses of less than 5 %. The specimens for the different graphites have been designed to ensure fracture within the gauge section commensurate with experienced variability in machining and testing care at different facilities. The constant gauge diameter permits rigorous analytical treatment.

¹ This test method is under the jurisdiction of ASTM Committee D02 on Petroleum Products and Lubricants and is the direct responsibility of Subcommittee D02.F0 on Manufactured Carbon and Graphite Products.

Current edition approved July 1, 2008. Published August 2008. Originally approved in 1973. Last previous edition approved in 2002 as C 749–92(2002).

² For referenced ASTM standards, visit the ASTM website, www.astm.org, or contact ASTM Customer Service at service@astm.org. For *Annual Book of ASTM Standards* volume information, refer to the standard's Document Summary page on the ASTM website.

*A Summary of Changes section appears at the end of this standard.

TABLE 1 Sample Sizes Used in Round-Robin Tests (Suggested Specimen Size)^A

Material ^B	Max Grain Size, in.	Sample, in.	Specimen Size, in.	Recommended Shank and Maximum Gauge, in.
AXM-50	0.001	5 by 5 by 5, molded	1/2 by 0.200 ^C	1/2 by 3/16 3/4 by 1/4
9326	0.001	20 by 10 by 2, molded	1/2 by 1/4 3/4 by 0.3 1/2 by 3/16 ^C	1/2 by 3/16 3/4 by 1/4 1/2 by 3/16
9326A	0.001	20 by 10 by 2, molded	1/2 by 1/4 3/4 by 3/8 3/4 by 0.3 3/4 by 3/8	3/4 by 0.3
ATJ	0.006	13, rounds, molded	1/2 by 1/4 3/4 by 3/8 3/4 by 3/8 3/4 by 3/8	1/2 by 1/4 3/4 by 1/4 3/4 by 1/4
HLM	0.033	molded, 10 by 18 by 25	1/2 by 1/4 3/4 by 3/8 3/4 by 3/8 3/4 by 3/8	3/4 by 3/8
CS	0.030	10, rounds, extruded	2 by 1 3/4 by 3/8 1/2 by 1/4 1/2 by 1/4	3/4 by 3/8
AGR	0.250	25, rounds, extruded	2 by 1 2 by 1 2 by 1 1 1/4 by 5/8	2 by 1 1 1/4 by 5/8
CGE	0.265	14, rounds, extruded	2 by 1 1/4 3/4 by 1/2	2 by 1
Graphitar Grade 86	...	carbon-graphite, resin impregnated	3/4 by 1/4 1/2 by 1/4 ^C 1/2 by 1/4	3/4 by 1/4 1/2 by 0.2
Purebon P-59	...	carbon-graphite, copper treated	3/4 by 1/4 1/2 by 1/4 ^C 1/2 by 1/4	3/4 by 1/4 1/2 by 3/16

^A Based on Research Report RR:C05-1000 (see Section 11).
^B Identity of suppliers available from ASTM International Headquarters.
^C Gas-bearings.

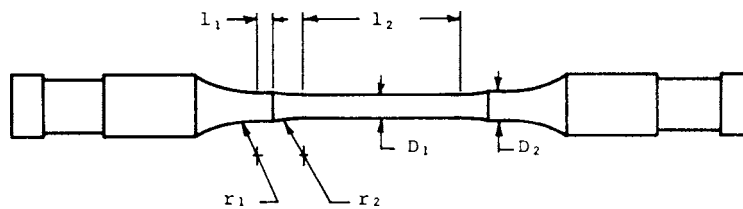

NOTE—Standard Specimen:

$r_1 = r_2$,
 $A_1 = A_2/1.2$,
 $l_1 = D_2/2$, and
 $l_2 = 2$ in. (51 mm) or $8 D_1$, whichever is greater.

FIG. 1 Double Reduction Used to Minimize Radii-Fractures

5.2 Carbon and graphite materials exhibit significant physical property differences within parent materials. Exact sampling patterns and grain orientations must be specified in order to make meaningful tensile strength comparisons. See also Test Methods C 565.

6. Apparatus

6.1 *Testing Machine*—The machine used for tensile testing shall conform to the requirements of Practices E 4. The testing machine shall have a load measurement capacity such that the

breaking load of the test specimen falls between 10 and 90 % of the scale or load cell capacity. This range must be linear to within 1 % over 1 % increments either by design or by calibration.

6.2 Strain Measurements:

6.2.1 The axial strain can be measured at room temperature by the use of strain gauges, mechanical extensometers, Tuckerman gauges, optical systems, or other devices applied diametrically opposite in the gauge length portion of the specimen. Two opposing gauges provide some compensation for

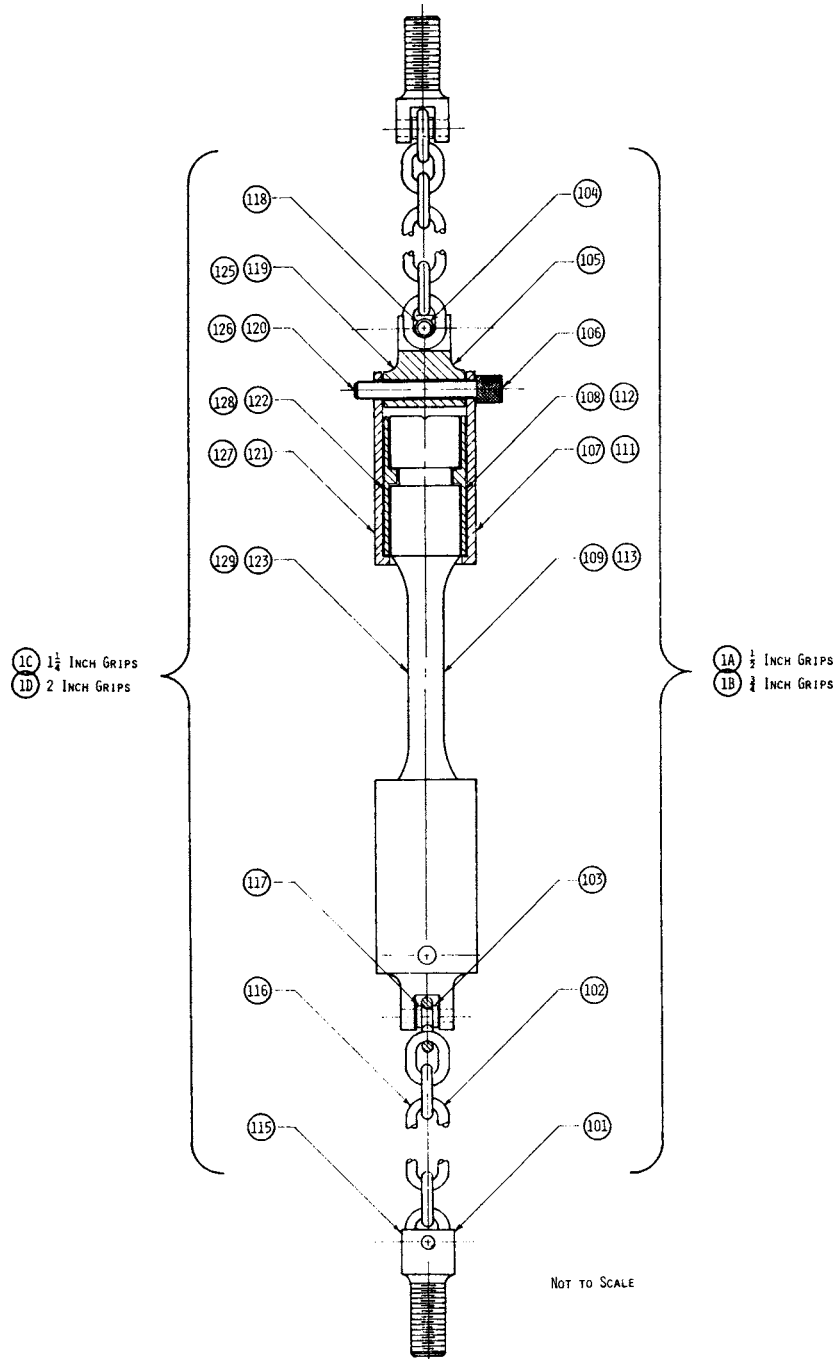

FIG. 2 Tensile Load Train Assembly

bending and some assurance that it was not severe. Different graphites require different attachment procedures and extreme care is necessary. A proven device for mounting the specimen with minimum damage and for enabling the specimen to receive different extensometers is shown in Fig. 10. When attaching strain gauges, the modification of the surface may result in a glue-graphite composite at the skin and thus the resulting strain values may be erroneous and typically low. When using clip-on extensometers, the knife edges can initiate fracture. Record, but do not include the fractures at the attachments in the averages. If more than 20 % of the failures

occur at the attachment location, change the strain monitoring system or attachment device.

6.2.2 The circumferential strain can be measured at room temperature by use of strain gauges applied circumferentially. Knowledge of the anisotropy in the billet and orientation of the specimen is necessary in order to properly place the strain-measuring device. Generally, one can expect three values of Poisson's ratio for a nonisotropic material. Hence, the strain sensing devices must be sized and positioned carefully. Note the limitations on strain gauges mentioned in 6.2.1.

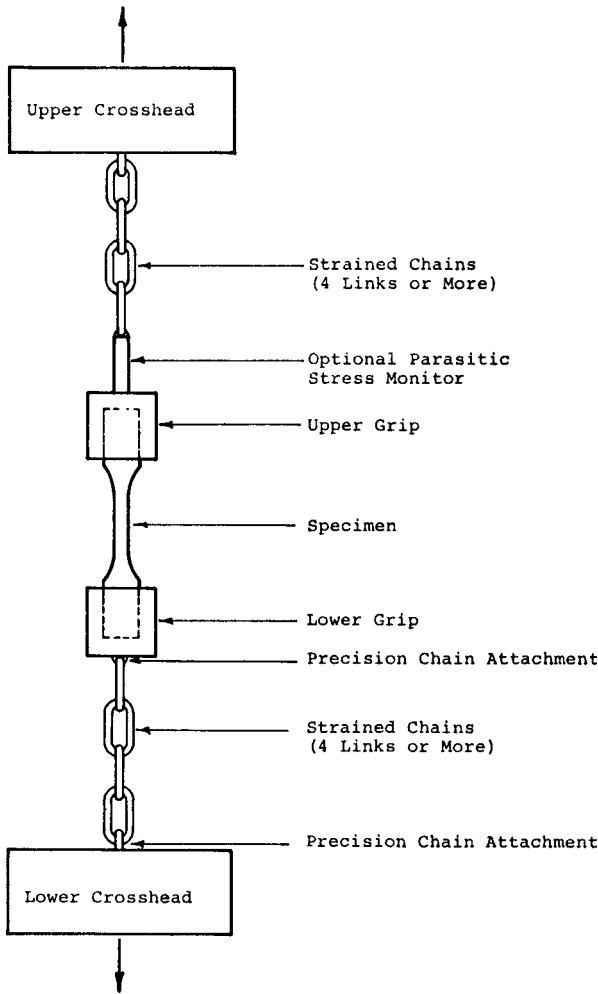

FIG. 3 Schematic of Tensile System for Carbon and Graphite

6.2.3 The diametral strains can be measured by most of the devices with limitations mentioned in 6.2.1 and 6.2.2.

6.3 *Parasitic Stress Monitor*—An optional parasitic stress monitor can be inserted as an extension of one of the grips. It shall be a steel rod about 4 in. long with strain gauges mounted at 90° angles to monitor axial bending moments on the rod and thus on the specimen. The rod shall be sized so that the bending moment applied to the specimen being used can be detected to within a 5 % parasitic stress in the outer fiber of the specimen. The parasitic stress shall be calculated elastically by translating the moment and assuming that the specimen is a free-end beam.

6.4 *Gripping Devices*—Gripping devices that conform to those shown in Fig. 2 shall be used. The centerlines of all connections must align to within the tolerances shown throughout the test.

6.5 *General Test Arrangement*—The general arrangement of the specimen, flexible linkages, and crossheads shall be as shown in the schematic of Fig. 3.

7. Test Specimens

7.1 Test specimens shall be produced to the general configurations shown in Fig. 9. The selection of the proper ratio of shank to gauge diameter is important to prevent excessive

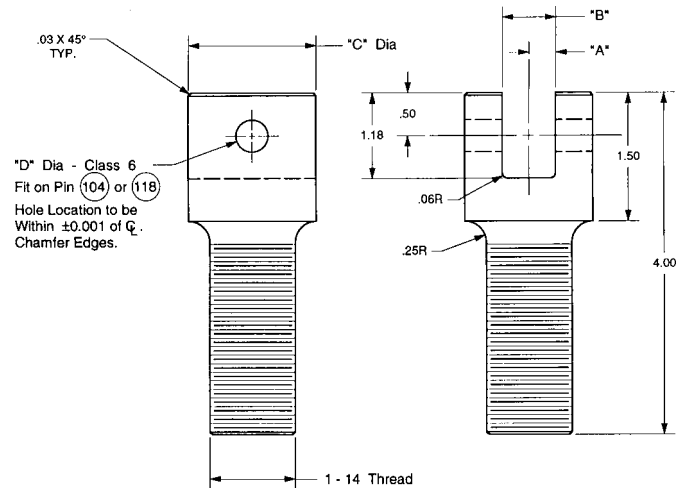

Dimensions, in. (mm)	Item	
	101	115
A	0.250 ± 0.001 (6.35 ± 0.03)	0.312 ± 0.001 (7.92 ± 0.03)
B	0.500 ± 0.001 (12.70 ± 0.03)	0.625 ± 0.001 (15.88 ± 0.03)
C	1.000 (25.40)	1.500 (38.10)
D	3/16 (4.76)	3/8 (9.52)

NOTE—Refer to Fig. 2, Items 101 and 115.

FIG. 4 Crosshead Attachment Yoke

head-pops or fracture of the specimen at the groove in the shanks. The ratios shown in Table 1 have been found satisfactory for this use. It is acceptable to double reduce gauge diameters as necessary (see Fig. 1) to eliminate head pops (or out-of-gauge fractures) or reduce them to an acceptable 20 % maximum of the total fractures. However, the reducing radius must be maintained near the values shown or excessive radii breaks will be obtained. Also, the gauge diameter should not be reduced to less than three to five times the maximum particles size in the material, or the failure mode may be atypical.

7.2 Improperly prepared test specimens often cause unsatisfactory test results. It is important, therefore, that care be exercised in the preparation of specimens both in minimizing end and side thrusts and in providing a quality surface. Either tool cutting or grinding is acceptable.

7.3 The gauge length of the specimen will be measured from the axial center of the specimen. Gauge marks can be applied with ink or layout dope but no scratching, punching, or notching of the specimen is permissible. The gauge length is to be used in referencing the point of fracture within 0.1 in. (2.5 mm). The total gauge length is defined as that section with the smaller uniform diameter extending from radius tangent to radius tangent plus 10 %. The additional 10 % is intended to accommodate the normal statistics of fracture for a material like graphite. However, at least 50 % of the specimens should fracture within the uniform diameter or the specimen should be redesigned and the system checked. Acceptable fracture locations are shown in Fig. 11.

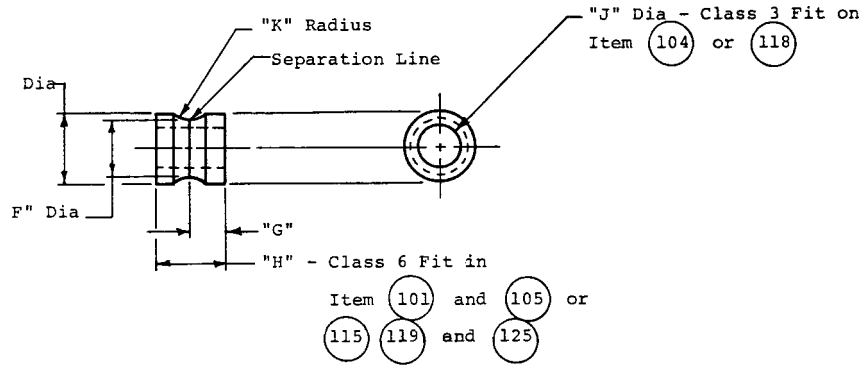

Not to Scale

Dimensions, in. (mm)	Item	
	103	117
E	$\frac{9}{16}$ (14.29)	$\frac{5}{8}$ (15.88)
F	$\frac{5}{16}$ (7.94)	$\frac{1}{2}$ (12.7)
G	0.250 ± 0.001 (6.35 \pm 0.03)	0.312 ± 0.001 (7.92 \pm 0.03)
H	0.500 (12.70)	0.625 (15.88)
J	$\frac{3}{16}$ (4.76)	$\frac{3}{8}$ (9.52)
K	$\frac{1}{8}$ (3.18)	$\frac{3}{16}$ (4.76)

NOTE—Refer to Fig. 2, Items 103 and 117.

FIG. 5 Chain Journal

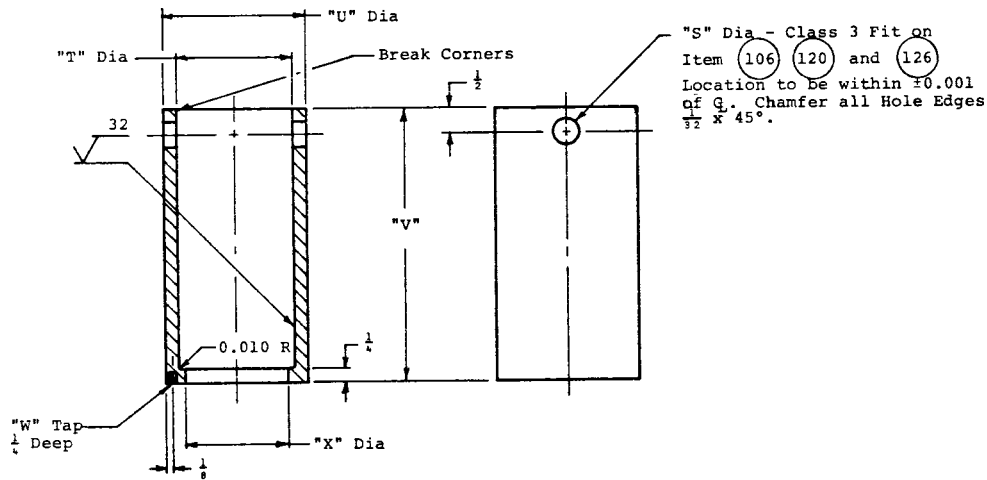

Not to Scale

Dimensions, in. (mm)	Item			
	107	111	121	127
S	$\frac{1}{4}$ (6.35)	$\frac{1}{4}$ (6.35)	$\frac{1}{2}$ (12.7)	$\frac{1}{2}$ (12.7)
T	1.000 ± 0.001 (25.40 \pm 0.03)	1.000 ± 0.001 (25.40 \pm 0.03)	1.500 ± 0.001 (38.10 \pm 0.03)	2.250 ± 0.001 (57.15 \pm 0.03)
U	1.500 (38.10)	1.500 (38.10)	1.875 (47.62)	2.750 (69.85)
V	$2\frac{5}{16}$ (58.74)	$2\frac{5}{16}$ (58.74)	$3\frac{3}{8}$ (92.07)	$5\frac{1}{2}$ (139.70)
W ^A	6-32	6-32	10-32	10-32
X	$0.500 + 0.002 - 0.000$ (12.70 + 0.05 - 0.00)	$0.750 + 0.002 - 0.000$ (19.05 + 0.05 - 0.00)	$1.250 + 0.002 - 0.000$ (31.75 + 0.05 - 0.00)	$2.000 + 0.002 - 0.000$ (50.80 + 0.05 - 0.00)

^A Screw size.

NOTE—Refer to Fig. 2, Items 107, 109, 111, 113, 121, 123, and 129.

FIG. 6 Grip Sleeve

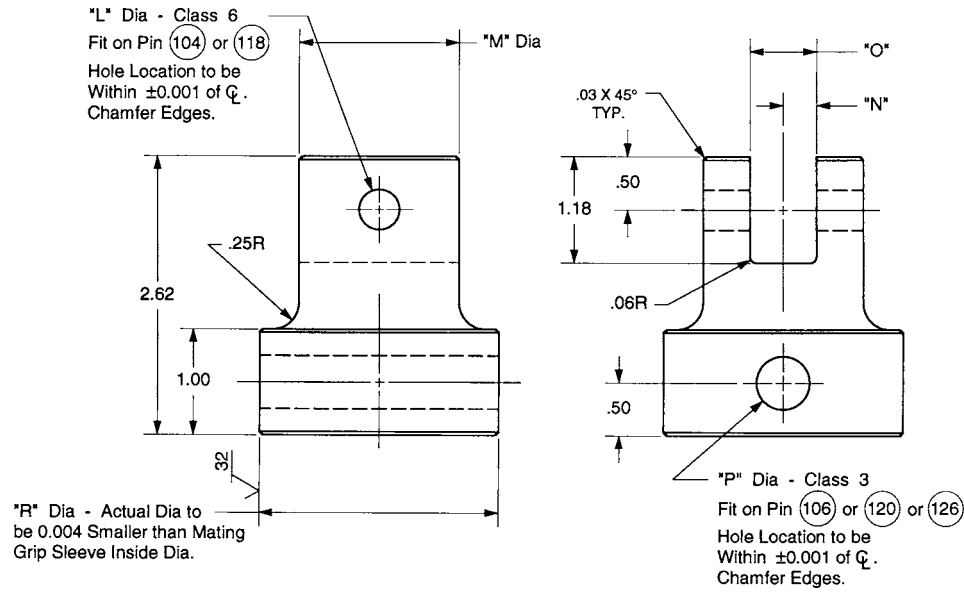

Dimensions of Specimen, in. (mm)	Item		
	109 and 113 (Ø ¼ and ⅜)	123 (Ø 0.625)	129 (Ø 1.000)
Dimensions of Grip Attachment Yoke, in. (mm)	Item		
	105	119	125
L	¾ (4.76)	⅜ (9.52)	⅜ (9.52)
M	1.000 (25.4)	1.500 (38.10)	1.500 (38.10)
N	0.250 ± 0.001 (6.35 ± 0.03)	0.312 ± 0.001 (7.92 ± 0.03)	0.312 ± 0.001 (7.92 ± 0.03)
O	0.500 ± 0.001 (12.70 ± 0.03)	0.625 ± 0.001 (15.88 ± 0.03)	0.625 ± 0.001 (15.88 ± 0.03)
P	¼ (6.35)	½ (12.7)	½ (12.7)
R	0.996 ± 0.001 (25.30 ± 0.03)	1.496 ± 0.001 (38.00 ± 0.03)	2.246 ± 0.001 (57.05 ± 0.03)

NOTE—Refer to Fig. 2, Items 105, 109, 113, 119, 123, 125, and 129.

FIG. 7 Grip Attachment Yoke

7.4 To determine the cross-sectional area, the diameter of the specimen at the smaller or constant diameter region shall be used. The dimension shall be recorded to the nearest 0.001 in. (0.0254 mm).

8. Procedure

8.1 Calibration—Calibrate the micrometres that are to be used for measurement of diameters by measuring the dimensions of blocks provided by the NBS that are accurate within ±0.0001 in. (0.00254 mm). Calibrate all instrumentation and establish shunt calibration for each recorded and each parameter. Zero all recorders.

8.2 Specimen—Adapt to the specimen the appropriate strain instrumentation by bonding strain gauges to its surface, adapting, or any other strain measuring system so that strain can be measured during the test. Place the specimen within the load train. Make sure all instrumentation is properly calibrated and zeroed.

8.3 Loading—Apply the load at a predetermined constant stress rate by following the appropriate load time curve either manually or automatically. Continuously apply the load until fracture is induced.

8.4 Recording—During the entire load application duration, record the output of the load cell on the vertical axis of an X-Y recorder and the strain on the horizontal axis, and obtain a

permanent record of the stress-strain curve for the specimen being tested during the entire test.

8.5 Post Test—Observed the specimen fracture surface. If the specimen failed outside the gauge length as defined in 6.3 (including head pops), the strength value measured must be reported but not included in the average.

9. Calculation

9.1 Calculate the strength as follows:

$$\sigma_{ult} = \frac{P_{max}}{A} \tag{1}$$

where:

- σ_{ult} = tensile strength, psi (Pa),
- P_{max} = maximum load, lbf (N), and
- A = cross-sectional area of the specimen in the constant diameter region or gauge section, in.²(m²).

9.1.1 The cross-sectional area is given by the equation:

$$A = \frac{\pi D^2}{4} \tag{2}$$

where:

- D = average diameter of the constant diameter region (gauge section) of the specimen, in. (m).

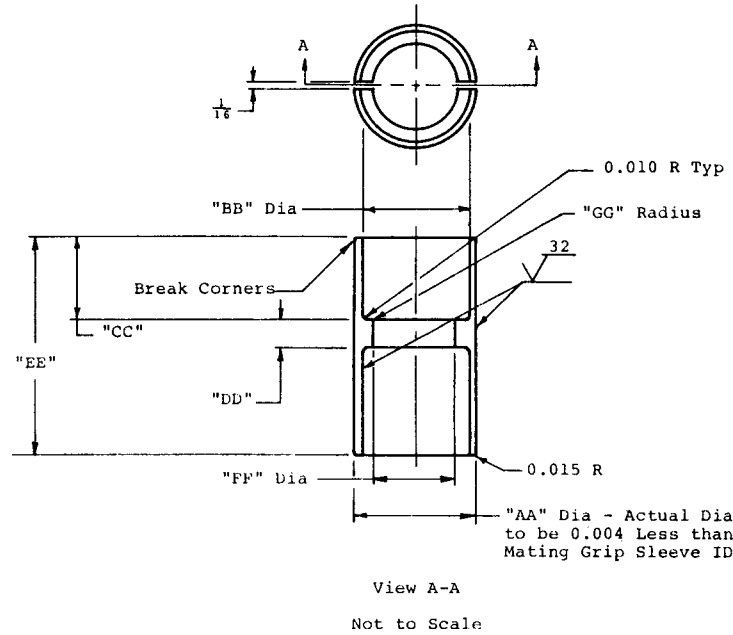

Dimensions, in. (mm)	Item			
	108	112	122	128
AA	0.996 ± 0.001 (25.30 ± 0.03)	0.996 ± 0.001 (25.30 ± 0.03)	1.496 ± 0.001 (38.00 ± 0.03)	2.246 ± 0.001 (57.05 ± 0.03)
BB	0.510 + 0.002 - 0.000 (12.95 + 0.05 - 0.00)	0.760 + 0.002 - 0.000 (19.30 + 0.05 - 0.00)	1.250 + 0.002 - 0.000 (31.75 + 0.05 - 0.00)	2.000 + 0.002 - 0.000 (50.80 + 0.03 - 0.00)
CC	0.635 (16.13)	0.635 (16.13)	1.250 (31.75)	1.500 (38.10)
DD	0.115 (2.92)	0.115 (2.92)	0.250 (6.35)	0.500 (12.70)
EE	1 (25.4)	1 (25.4)	2¼ (57.15)	4 (102)
FF	0.400 (10.16)	0.650 (16.51)	1.000 (25.40)	1.500 (38.10)
GG	0.035 (0.89)	0.035 (0.89)	0.065 (1.65)	0.125 (3.18)

NOTE—Refer to Fig. 2, Items 108, 112, 122, and 128.

FIG. 8 Split Sleeve

9.2 Calculate modulus of elasticity of the specimen from the stress-strain curve as follows:

$$E = \text{initial slope of stress-strain curve} = \frac{\Delta\sigma}{\Delta\varepsilon} \quad (3)$$

where:

- E = modulus of elasticity, psi (Pa),
- $\Delta\sigma$ = incremental stress corresponding to the incremental strain, psi (Pa), and
- $\Delta\varepsilon$ = incremental strain corresponding to the incremental stress, in./in. (m/m).

9.3 Determine the strain-to-failure from the stress-strain curve as the strain where the maximum stress was obtained and the specimen failed.

10. Report

10.1 Report the following information:

- 10.1.1 Test configuration, load rate, load calibrations, and other general testing information,
- 10.1.2 Material identification: manufacturer, grade number, lot number, original billet size, maximum grain size, and other data, where available,
- 10.1.3 Description of the specimen including orientation and position in billet,
- 10.1.4 Description of procedures and other environmental exposures,

10.1.5 All individual and average ultimate tensile strength values,

10.1.6 Individual and average strain-to-failure values and details on the method of attachment of the strain sensing device. If elastic constants are given, the method of determining them (including the portion of the stress-strain curve used) and their orientation should be reported,

10.1.7 Data for all samples tested including the monitored parasitic moment and calculated parasitic stress,

10.1.8 A record of all specimens that broke during machining or subsequent handling after they had been reduced to the nominal diameter used in the grips,

10.1.9 Standard deviation, coefficient of variation of all properties, or both. Usually, at least five to ten values are required for these numbers to have significance, and

10.1.10 Axial fracture location (see Fig. 11).

11. Precision and Bias ³

11.1 *Precision*—The precision statements given in this section are based on the comparison of the mean strength by the

³ Supporting data have been filed at ASTM International Headquarters and may be obtained by requesting Research Report RR: C05-1000.

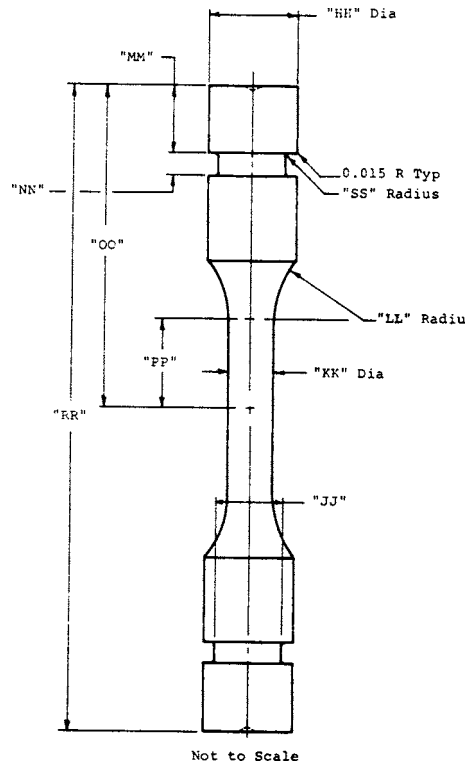

Dimensions, in. (mm)	Item			
	109	113	123	129
HH	0.510 + 0.000 – 0.002 (12.95 + 0.00 – 0.05)	0.760 + 0.000 – 0.002 (19.30 + 0.00 – 0.05)	1.250 + 0.000 – 0.002 (31.75 + 0.00 – 0.05)	2.000 + 0.000 – 0.002 (50.80 + 0.00 – 0.05)
JJ	0.390 (9.91)	0.640 (16.26)	0.990 (25.15)	1.490 (37.85)
KK	0.250 ± 0.002 (6.35 ± 0.05)	0.375 ± 0.002 (9.52 ± 0.05)	0.625 ± 0.002 (15.88 ± 0.05)	1.000 ± 0.002 (25.40 ± 0.05)
LL	1 (25.4)	1 (25.4)	2 (50.8)	2 (50.8)
MM	0.635 (16.13)	0.635 (16.13)	1.250 (31.75)	1.500 (38.10)
NN	0.125 (31.75)	0.125 (31.75)	0.255 (6.48)	0.505 (12.83)
OO	2 3/8 (60.32)	2 3/8 (60.32)	4 7/8 (123.82)	7 3/16 (182.56)
PP	7/8 (22.22)	7/8 (22.22)	1 1/4 (31.75)	2 (50.8)
RR	4 3/4 (120.65)	4 3/4 (120.65)	9 3/4 (247.65)	14 3/8 (365.12)
SS	0.030 + 0.000 – 0.005 (0.76 + 0.00 – 0.13)	0.030 + 0.000 – 0.005 (0.76 + 0.00 – 0.13)	0.060 + 0.000 – 0.005 (1.52 + 0.00 – 0.13)	0.120 + 0.000 – 0.005 (3.05 + 0.00 – 0.13)

NOTE—Refer to Fig. 2, Items 109, 113, 123, and 129.

FIG. 9 Specimen

student *t* test and carrying out the statistical analysis of the data obtained on materials tested in a round-robin as recommended by Practice E 691.

11.1.1 *Comparison of the Means*—The comparison of the means by the student *t* test leads to the conclusion that the average of the strength values measured by each laboratory for each material can be considered statistically equal at a 95 % confidence level.

11.1.2 *Repeatability (Single Instrument)*—The precision within laboratory of two single values of measured strength using the Practice E 177 definition with the pooled standard deviation calculated using Practice E 691:

$$\text{Repeatability within laboratory} = 2 (S_p)_j \quad (4)$$

which yields values for the materials used for the round-robin ranging from 244 to 920 psi (1.68 to 6.34 MPa). These values convert into strength percentages ranging from ±6 to ±11 depending on the strength variability of the material.

11.1.3 *Repeatability (Multi-Instrument)*—The precision between laboratories of two single values of measured strength using the Practice E 177 definition with the component of variance between laboratories calculated using Practice E 691:

$$\text{Repeatability between laboratories} = 2 (S_L)_j \quad (5)$$

which yields values for the materials used for the round-robin ranging from 22 to 168 psi (0.15 to 1.15 MPa). These values convert into strength percentages ranging from ±0.7 to ±2.2 depending on the strength variability of the material.

11.2 *Bias*—No true statement on bias can be made because no reference carbon or graphite material exists. Nevertheless, comparison of the tensile strength of one of the graphite materials measured by this test method, with the tensile strength obtained by highly controlled test procedures using highly specialized test equipment especially designed for testing of brittle materials, revealed a confidence level of

TABLE 2 List of Materials Shown in Fig. 2

Assembly	Item	Quantity	Name, Description, Material
1A 1/2 in. ^A grips ^{B,C}	101	2	Crosshead attachment yoke—1 dia x 4 long—416 or 440 S.S.
	102	2	Chain—3/16 dia, 700 pound tensile limit, 10 links long—Carbon Steel
	103	4	Chain journal—9/16 dia x 1/2 long—416 or 440 S.S.
	104	4	Pin—3/16 dia x 1—Std Dowel
	105	2	Grip attachment yoke—1 dia x 2 5/8 long—416 or 440 S.S.
	106	2	Pin—1/4 shank dia with 1/2 dia x 3/4 long knurled head, total length 2 1/2, taper first half inch at 10°—416 or 440 S.S.
	107	2	Grip sleeve—1 1/2 dia x 2 5/16 long—416 or 440 S.S.
	108	2	Split sleeve—1 dia x 1 long—416 or 440 S.S.
	109	1	Specimen—0.510 dia x 4 3/4 long—Carbon
	110		Not Used
	1B 3/4 in. ^A grips	...	2
...		2	Item 102—Chain
...		4	Item 103—Chain journal
...		4	Item 104—Pin
...		2	Item 105—Grip attachment yoke
...		2	Item 106—Pin
111		2	Grip sleeve—1 1/2 dia x 2 5/16 long—416 or 440 S.S.
112		2	Split sleeve—1 dia x 1 long—416 or 440 S.S.
113		1	Specimen—0.760 dia x 4 3/4 long—Carbon
114			Not Used
1C 1 1/4 in. ^A grips		115	2
	116	2	Chain—3/8 dia, 5100 pound tensile limit, 10 links long—Carbon Steel
	117	4	Chain journal—5/8 dia x 5/8 long—416 or 440 S.S.
	118	4	Pin—3/8 dia x 1 1/2 long—Std Dowel
	119	2	Grip attachment yoke—1 1/2 dia x 2 5/8 long—416 or 440 S.S.
	120	2	Pin—1/2 shank dia with 3/4 dia x 3/4 long knurled head, total length 4 1/4, taper first half inch at 10°—416 or 440 S.S.
	121	2	Grip sleeve—1 7/8 dia x 3 5/8 long—416 or 440 S.S.
	122	2	Split sleeve—1 1/2 dia x 2 1/4 long—416 or 440 S.S.
	123	1	Specimen—1 1/4 dia x 9 3/4 long—Carbon
	124		Not Used
	1D 2 in. ^A grips	...	2
...		2	Item 116—Chain
...		4	Item 117—Chain journal
...		4	Item 118—Pin
125		2	Grip attachment yoke—2 1/4 dia x 2 5/8 long—416 or 440 S.S.
126		2	Pin—1/2 shank dia with 3/4 dia x 3/4 long knurled head, total length 4 1/4, taper first half inch at 10°—416 or 440 S.S.
127		2	Grip sleeve—2 3/4 dia x 5 1/2 long—416 or 440 S.S.
128		2	Split sleeve—2 1/4 dia x 4 long—416 or 440 S.S.
129		1	Specimen—2.000 dia x 14 3/8 long—Carbon
130			Not Used

^A 1 in. is equal to 25.4 mm.

^B Preload chain to yield using a load time recording.

^C Commercially available.

99.5 %. The two average values compared were equal. Another important point brought about by the review of the data and comparison was that in the other test method, the coefficient of variation was $\pm 6\%$ with an average measured parasitic of less than 2 %, indicating that the tensile strength of carbon and graphite vary widely due only to material variability. Therefore, most of the variability revealed by the data is related to material variation and not to test method. But, because the user of the test method cannot distinguish between material, test method, and other imprecisions, the precision statement given

in this section is based on the materials tested in the round-robin used to establish the reproducibility of the test procedure.

11.3 *Application*—The measurement of strain was not included in the round-robin. This precision and bias statement applies to ultimate strength only.

12. Keywords

12.1 carbon; graphite; modulus of elasticity; tensile strain to failure; tensile strength

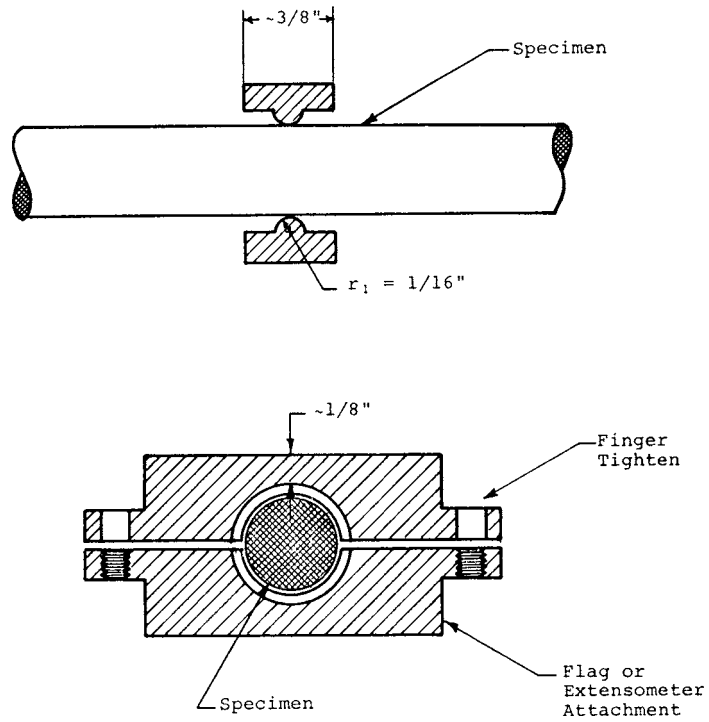

NOTE—Jig align to ensure precision gauge length; mount post or groove to match type of extensometer.

FIG. 10 Attachment for Strain Flags or Extensometers to Provide Minimum Damage to Surface of Specimen

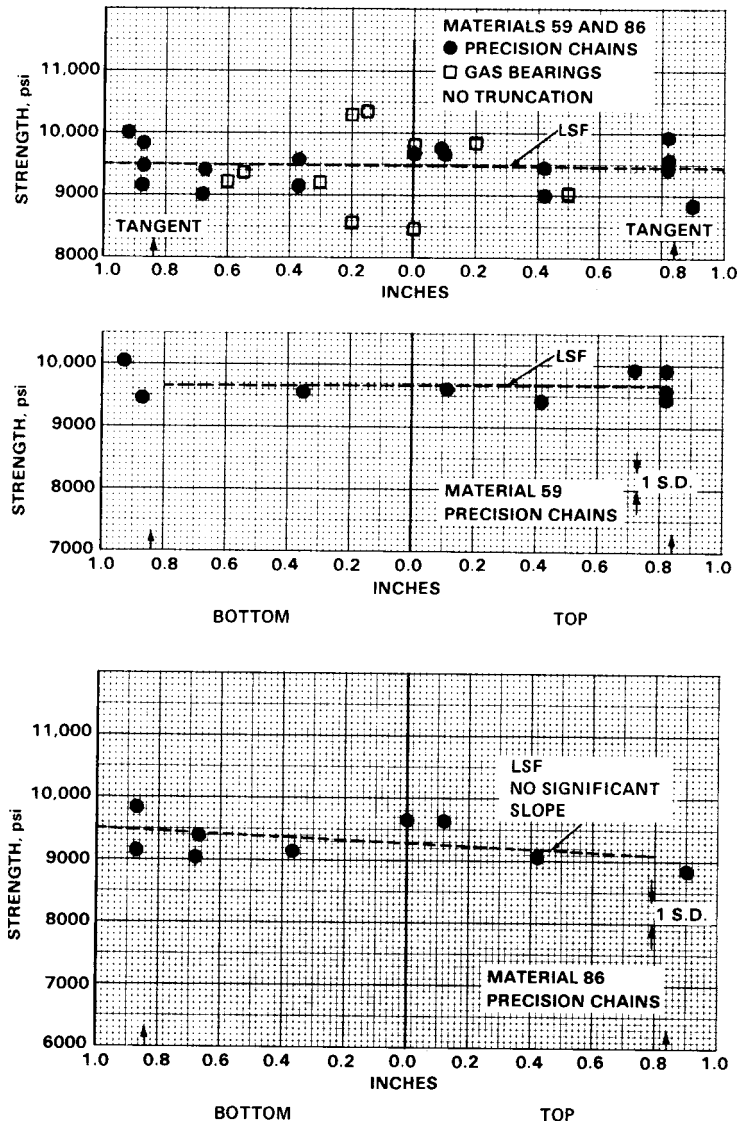

NOTE—1 in. = 25.4 mm.
 LSF = Least Squares Ft.
 D = Standard Deviation.

FIG. 11 Fracture Location versus Strength for Two Impregnated Carbons (Worst Case)

SUMMARY OF CHANGES

Subcommittee D02.F0 has identified the location of selected changes to this standard since the last issue (C 749-92(2002)) that may impact the use of this standard.

- (1) This test method has been revised to improve clarity, add a cautionary note regarding graphite texture, and to correct a tolerance error that allowed a dimensional interference between the specimen and the grips.

ASTM International takes no position respecting the validity of any patent rights asserted in connection with any item mentioned in this standard. Users of this standard are expressly advised that determination of the validity of any such patent rights, and the risk of infringement of such rights, are entirely their own responsibility.

This standard is subject to revision at any time by the responsible technical committee and must be reviewed every five years and if not revised, either reapproved or withdrawn. Your comments are invited either for revision of this standard or for additional standards and should be addressed to ASTM International Headquarters. Your comments will receive careful consideration at a meeting of the responsible technical committee, which you may attend. If you feel that your comments have not received a fair hearing you should make your views known to the ASTM Committee on Standards, at the address shown below.

This standard is copyrighted by ASTM International, 100 Barr Harbor Drive, PO Box C700, West Conshohocken, PA 19428-2959, United States. Individual reprints (single or multiple copies) of this standard may be obtained by contacting ASTM at the above address or at 610-832-9585 (phone), 610-832-9555 (fax), or service@astm.org (e-mail); or through the ASTM website (www.astm.org).