



Standard Test Methods for Chemical, Mass Spectrometric, Spectrochemical, Nuclear, and Radiochemical Analysis of Uranium Hexafluoride¹

This standard is issued under the fixed designation C 761; the number immediately following the designation indicates the year of original adoption or, in the case of revision, the year of last revision. A number in parentheses indicates the year of last reapproval. A superscript epsilon (ε) indicates an editorial change since the last revision or reapproval.

This standard has been approved for use by agencies of the Department of Defense. 4

^{ε1} NOTE—Two versions of Table 1 appeared in this standard. The incorrect version was editorially deleted.

1. Scope

1.1 These test methods cover procedures for subsampling and for chemical, mass spectrometric, spectrochemical, nuclear, and radiochemical analysis of uranium hexafluoride (UF₆). Most of these test methods are in routine use to determine conformance to UF₆ specifications in the Enrichment and Conversion Facilities.

1.2 The analytical procedures in this document appear in the following order:

NOTE 1—Subcommittee C26.05 will confer with C26.02 concerning the renumbered section in Test Methods C761 to determine how concerns with renumbering these sections, as analytical methods are replaced with stand-alone analytical methods, are best addressed in subsequent publications.

	Sections
Subsampling of Uranium Hexafluoride	7 – 10
Gravimetric Determination of Uranium	11 – 19
Titrimetric Determination of Uranium	20
Preparation of High-Purity U ₃ O ₈	21
Isotopic Analysis	22
Isotopic Analysis by Double-Standard Mass-Spectrometer Method	23 - 29
Determination of Hydrocarbons, Chlorocarbons, and Partially Substituted Halohydrocarbons	29–36
Atomic Absorption Determination of Antimony	36
Spectrophotometric Determination of Bromine	37
Titrimetric Determination of Chlorine	38–44
Determination of Silicon and Phosphorus	45–51
Determination of Boron and Silicon	52–59
Determination of Ruthenium	60
Determination of Titanium and Vanadium	61
Spectrographic Determination of Metallic Impurities	62
Determination of Tungsten	63
Determination of Thorium and Rare Earths	64–69
Determination of Molybdenum	70
Atomic Absorption Determination of Metallic Impurities	71–76
Impurity Determination by Spark-Source Mass Spectrography	77
Determination of Boron-Equivalent Neutron Cross Section	78
Determination of Uranium-233 Abundance by Thermal Ionization Mass Spectrometry	79

Determination of Uranium-232 by Alpha Spectrometry	80–86
Determination of Fission Product Activity	87
Determination of Plutonium by Ion Exchange and Alpha Counting	88–92
Determination of Plutonium by Extraction and Alpha Counting	93–100
Determination of Neptunium by Extraction and Alpha Counting	101–108
Atomic Absorption Determination of Chromium Soluble In Uranium Hexafluoride	109–115
Atomic Absorption Determination of Chromium Insoluble In Uranium Hexafluoride	116–122
Determination of Technetium-99 In Uranium Hexafluoride	123–131
Method for the Determination of Gamma-Energy Emission Rate from Fission Products in Uranium Hexafluoride	132
Determination of Metallic Impurities by ICP-AES	133–142
Determination of Molybdenum, Niobium, Tantalum, Titanium, and Tungsten by ICP-AES	143–152

1.3 *This standard does not purport to address all of the safety concerns, if any, associated with its use. It is the responsibility of the user of this standard to establish appropriate safety and health practices and determine the applicability of regulatory limitations prior to use. (For specific safeguard and safety consideration statements, see Section 6.)*

2. Referenced Documents

2.1 The following documents of the issue in effect on date of material procurement form a part of this specification to the extent referenced herein:

2.2 ASTM Standards:²

- C 696 Test Methods for Chemical, Mass Spectrometric, and Spectrochemical Analysis of Nuclear-Grade Uranium Dioxide Powders and Pellets
- C 753 Specification for Nuclear-Grade, Sinterable Uranium Dioxide Powder
- C 787 Specification for Uranium Hexafluoride for Enrichment
- C 799 Test Methods for Chemical, Mass Spectrometric, Spectrochemical, Nuclear, and Radiochemical Analysis of Nuclear-Grade Uranyl Nitrate Solutions
- C 996 Specification for Uranium Hexafluoride Enriched to

¹ These test methods are under the jurisdiction of ASTM Committee C26 on Nuclear Fuel Cycle and are the direct responsibility of Subcommittee C26.05 on Methods of Test.

Current edition approved July 1, 2004. Published August 2004. Originally approved in 1973. Last previous edition approved in 2001 as C 761 – 01.

² For referenced ASTM standards, visit the ASTM website, www.astm.org, or contact ASTM Customer Service at service@astm.org. For *Annual Book of ASTM Standards* volume information, refer to the standard's Document Summary page on the ASTM website.

Less Than 5% ²³⁵U

- C 1128** Preparation of Working Reference Materials for Use in the Analysis of Nuclear Fuel Cycle Materials
 - C 1219** Test Methods for Arsenic in Uranium Hexafluoride
 - C 1233** Practice for Determining Equivalent Boron Contents of Nuclear Materials
 - C 1267** Test Method for Uranium by Iron (II) Reduction in Phosphoric Acid Followed by Chromium (VI) Titration in the Presence of Vanadium
 - C 1287** Test Method for Determination of Impurities in Uranium Dioxide by Inductively Coupled Plasma Mass Spectrometry
 - C 1295** Test Method for Gamma Energy Emission from Fission Products in Uranium Hexafluoride²
 - C 1344** Test Method for Isotopic Analysis of Uranium Hexafluoride by Single-Standard Gas Source Mass Spectrometer Method
 - C 1346** Practice for Dissolution of UF₆ from P-10 Tubes
 - C 1380** Test Method for the Determination of Uranium Content and Isotopic Composition of Isotope Dilution Mass Spectrometry
 - C 1413** Test Method for Isotopic Analysis of Hydrolyzed Uranium Hexafluoride and Uranyl Nitrate Solutions By Thermal Ionization Mass Spectrometry
 - C 1428** Test Method for Isotopic Analysis of Uranium Hexafluoride by Single-Standard Gas Source Multiple Collector Mass Spectrometer Method
 - C 1429** Test Method for Isotopic Analysis of Uranium Hexafluoride by Double-Standard Multi-Collector Gas Mass Spectrometer
 - C 1441** Test Method for the Analysis of Refrigerant 114, Plus Other Carbon-Containing and Fluorine-Containing Compounds in Uranium Hexafluoride via Fourier-Transform Infrared (FTIR) Spectroscopy
 - C 1474** Test Method for Analysis of Isotopic Composition of Uranium in Nuclear-Grade Fuel Material by Quadrupole Inductively Coupled Plasma-Mass Spectrometry
 - C 1477** Test Method for Isotopic Abundance Analysis of Uranium Hexafluoride by Multi-collector Inductively Coupled Plasma-Mass Spectrometry
 - C 1508** Test Method for Determination of Bromine and Chlorine in UF₆ and Uranyl Nitrate by X-Ray Fluorescence
 - D 1193** Specification for Reagent Water
 - E 60** Practice for Photometric and Spectrophotometric Methods for Chemical Analysis of Metals
 - E 115** Practice for Photographic Processing in Optical Emission Spectrographic Analysis
 - E 130** Practice for Designation of Shapes and Sizes of Graphite Electrodes
- 2.3 *American Chemical Society Specification:*
Reagent Chemicals³
- 2.4 *Other Specifications:*

Uranium Hexafluoride: Base Charges, Use Charges, Special Charges, Table of Enriching Services, Specifications, and Packaging⁴

USEC 651 Good Handling and Practices for UF₆

2.5 *ANSI Standards:*⁵

ANSI N 14.1 Nuclear Material- Uranium Hexafluoride- Packaging for Transport

ISO 7195 Nuclear Energy-Packaging of Uranium Hexafluoride (UF₆) for Transport

3. Significance and Use

3.1 Uranium hexafluoride is a basic material used to prepare nuclear reactor fuel. To be suitable for this purpose the material must meet criteria for uranium content, isotopic composition, metallic impurities, hydrocarbon and halo-hydrocarbon content. These test methods are designed to determine whether the material meets the requirements described in Specification **C 787**.

4. Reagents

4.1 *Purity of Reagents*—Reagent grade chemicals shall be used in all procedures. Unless otherwise indicated, all reagents shall conform to the specifications of the Committee on Analytical Reagents of the American Chemical Society, where such specifications are available.⁶ Other grades may be used, provided that it is first established that the reagent to be used is of sufficiently high purity to permit its use without lessening the accuracy of the determination.

4.2 *Purity of Water*—Unless otherwise indicated, references to water shall mean reagent water conforming to Specification **D 1193**.⁷

5. Rejection

5.1 Rejection or acceptance criteria are described in Specifications **C 787** and **C 996**.

6. Safety Considerations

6.1 Since UF₆ is radioactive, toxic, and highly reactive, especially with reducing substances and moisture (see Uranium Hexafluoride: Handling Procedures and Container Criteria), appropriate facilities and practices for sampling and analysis must be provided.

6.2 *Committee C-26 Safeguards Statement:*

6.2.1 The material (uranium hexafluoride) to which these test methods apply, is subject to nuclear safeguards regulations governing its possession and use. The following analytical procedures in these test methods have been designated as technically acceptable for generating safeguards accountability measurement data: Gravimetric Determination of Uranium; Titrimetric Determination of Uranium; All Isotopic Analyses.

⁴ United States Department of Energy, Oak Ridge, TN 37830.

⁵ Available from American National Standards Institute (ANSI), 25 W. 43rd St., 4th Floor, New York, NY 10036.

⁶ The boldface numbers in parentheses refer to a list of references at the end of these test methods.

⁷ Type 1 and 2 water have been found to be suitable.

³ "Reagent Chemicals, American Chemical Society Specifications," Washington, DC. For suggestions on the testing of reagents not listed by the American Chemical Society, See "Reagent Chemicals and Standards," by Joseph Rosin, D. Van Nostrand Co., Inc., New York, NY, and the "United States Pharmacopeia."

6.2.2 When used in conjunction with appropriate certified Reference Materials (CRMs), these procedures can demonstrate traceability to the national measurement base. However, adherence to these procedures does not automatically guarantee regulatory acceptance of the resulting safeguards measurements. It remains the sole responsibility of the user of these test methods to assure that its application to safeguards has the approval of the proper regulatory authorities.

SUBSAMPLING OF URANIUM HEXAFLUORIDE (1, 2)⁶

7. Scope

7.1 This test method is applicable to the subsampling (3) of UF₆ from bulk sample containers into smaller containers suitable for laboratory analyses. The procedure includes sample filtration that facilitates determination of both soluble and insoluble chromium compounds.

8. Summary of Test Method

8.1 The UF₆ in the bulk sample container is liquefied and homogenized by vigorous shaking. The container is inverted and connected to the top of a heated vacuum-manifold system, and the subsample container is attached to the appropriate port of the system. The system is evacuated, and the liquid UF₆ is allowed to flow by gravity into the subsample container. Table 1 summarizes the purpose of various subsamplings.

8.2 If the determination of the volatile component of an impurity is needed (for example, chromium compounds), a total gas transfer may be necessary. In such case, the tared liquid UF₆ bulk sample container is connected to the top of the heated manifold without inversion, so that gaseous UF₆ is transferred.

9. Apparatus

9.1 Hot Water Bath.

9.2 Heated Vacuum Manifold with Liquid Nitrogen Cold Trap (Table 1).

TABLE 1 – Subsamples for UF₆ Specification Analyses

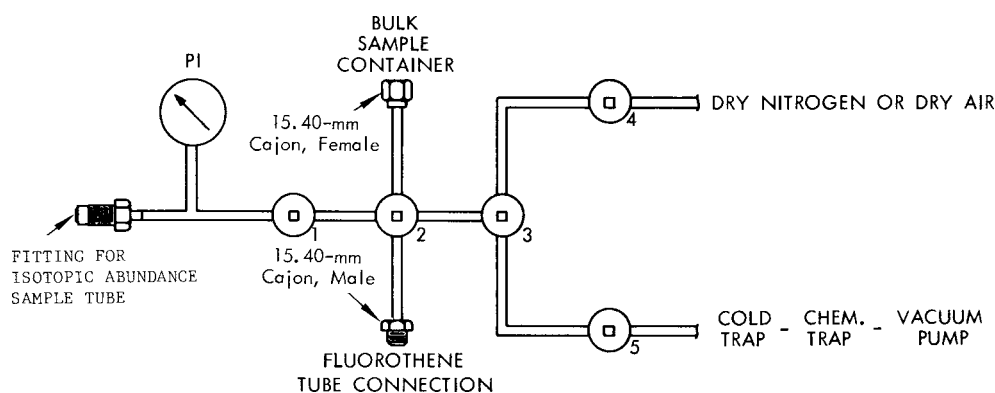
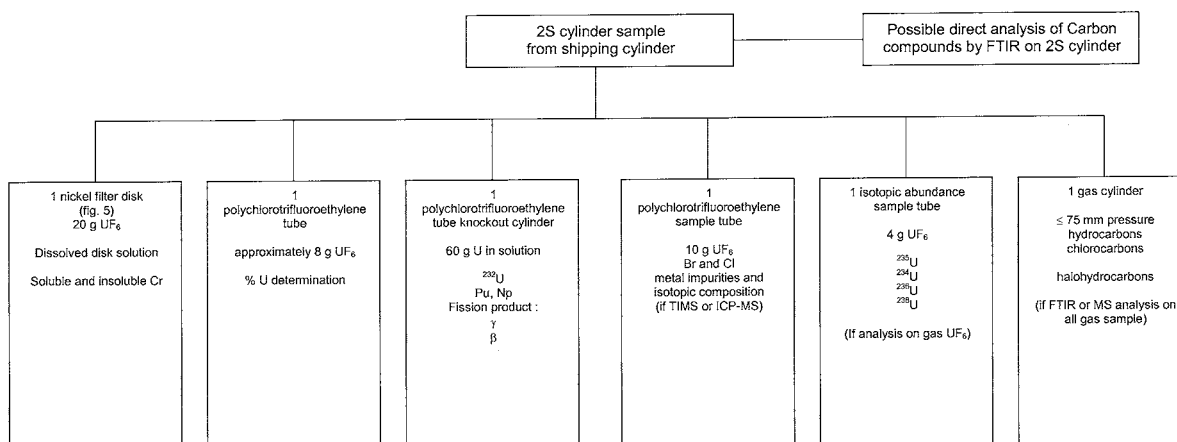

NOTE 1—All lines are 3/8-in. (9.5-mm) Monel tubing.

NOTE 2—All valves are Monel diaphragm-type valves.

NOTE 3—The valves and lines are wrapped with heating tape to maintain a system temperature of about 80°C.

NOTE 4—Valve 2 is a 3-way valve modified to make it a 4-way valve. When the valve is closed, the polychlorotrifluoroethylene tube is isolated from the system, but the lines from Valve 1 to Valve 3 and to the bulk container are open.

- 9.3 Gaseous Isotopic Abundance Sample Tube (Fig. 1).
- 9.4 Polychlorotrifluoroethylene Sample Tube (Fig. 2).
- 9.5 Polychlorotrifluoroethylene Knockout Cylinder (Fig. 3), closed with a Cajon⁸ M-16 VCR-1 female nut and an M-16 VCR-4 male nut, or equivalent.
- 9.6 Nickel Filter Disk, porous, 2- μ m, free of chromium (Fig. 4). Mott Metallurgical Corp. or equivalent.⁹
- 9.7 Gas Sample Cylinder, 0.5 L.

10. Procedure

10.1 System Preparation:

10.1.1 Place the bulk sample container in a water bath at 90°C \pm 3°C.

10.1.2 After the UF₆ has been liquefied, remove the container from the bath, shake to homogenize the sample, and connect it at the top of the vacuum-manifold system shown in Table 1. The container will be inverted if liquid UF₆ must be subsampled.

10.1.3 When a liquid subsample is required for uranium analysis or chemical impurity (metal, halogen), and TIMS isotopic analysis, connect a tared polychlorotrifluoroethylene sample tube at the Cajon connection at the bottom of the system. If this subsample is not required, attach a blind fitting at this point.

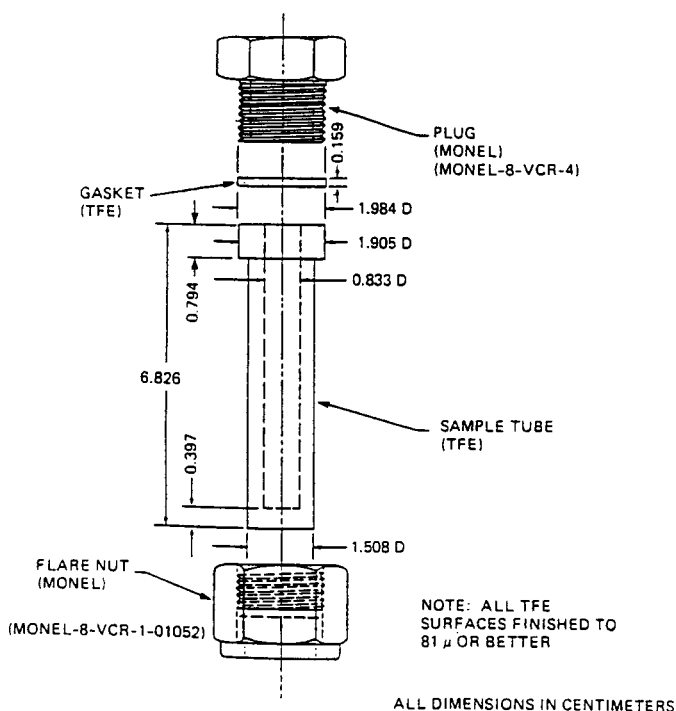

FIG. 2 Small TFCE Sample Tube

⁸ Brand names mentioned in this procedure are intended to be typical, not limiting. Another brand of comparable characteristics could perform equally well.

⁹ The filter disk should weigh approximately 1 g and be 16 mm in diameter by 0.6 mm thick. It should be of nickel powder produced from carbonyl nickel and formed by the no pressure sintering method in graphite or ceramic molds.

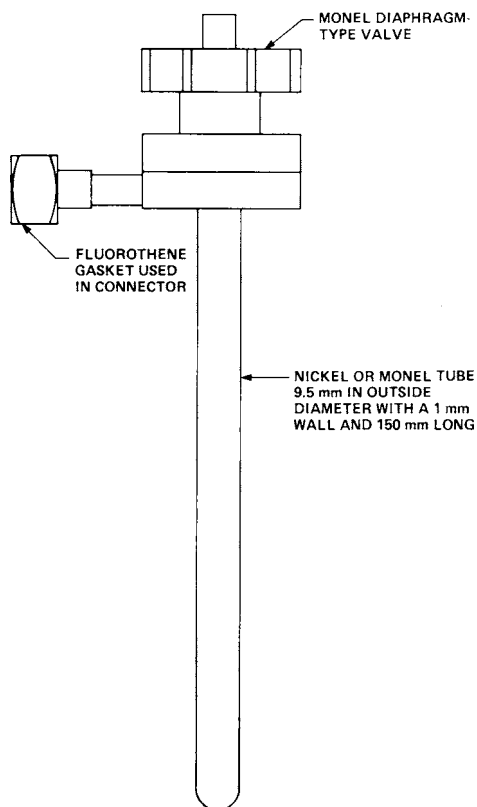

FIG. 1 Isotopic Abundance Sample Tube

10.1.4 When a liquid subsample is required for gaseous isotopic analysis or all gas carbon compound determination, attach a tared isotopic abundance sample tube to the sample tube connection. If a subsample is not required, attach a cap at this point.

10.1.5 When a total gas UF₆ transfer is necessary, connect the UF₆ bulk container without inversion. Attach a polychlorotrifluoroethylene knockout cylinder at the tube connection and attach a cap at the fitting for isotopic abundance sample tube.

10.1.6 Close Valve 4, then evacuate the entire system, except for the UF₆ bulk sample container.

10.2 Sample Transfer to the polychlorotrifluoroethylene Tube:

10.2.1 Close Valves 1, 2, and 3.

10.2.2 To remove solid impurities, which may be present in the bulk-container valve, open that valve and then close it quickly. Transfer this flush aliquot of liquid UF₆ to a polychlorotrifluoroethylene sample tube, as described below, and discard.

10.2.3 Open the bulk-container valve; then open Valve 2 slowly, allowing liquid UF₆ to flow into the polychlorotrifluoroethylene tube. When the tube is half full of liquid UF₆, close Valve 2.

10.2.4 Close the bulk-container valve.

10.2.5 Open Valve 3 to remove UF₆ from the system. Open Valve 1 to ensure that the system is evacuated.

10.2.6 Close Valve 3.

10.2.7 Immerse the polychlorotrifluoroethylene tube in liquid nitrogen for 6 min.

10.2.8 Open Valve 2 to ensure that the sample does not exert a detectable vapor pressure.

10.2.9 Close Valve 5.

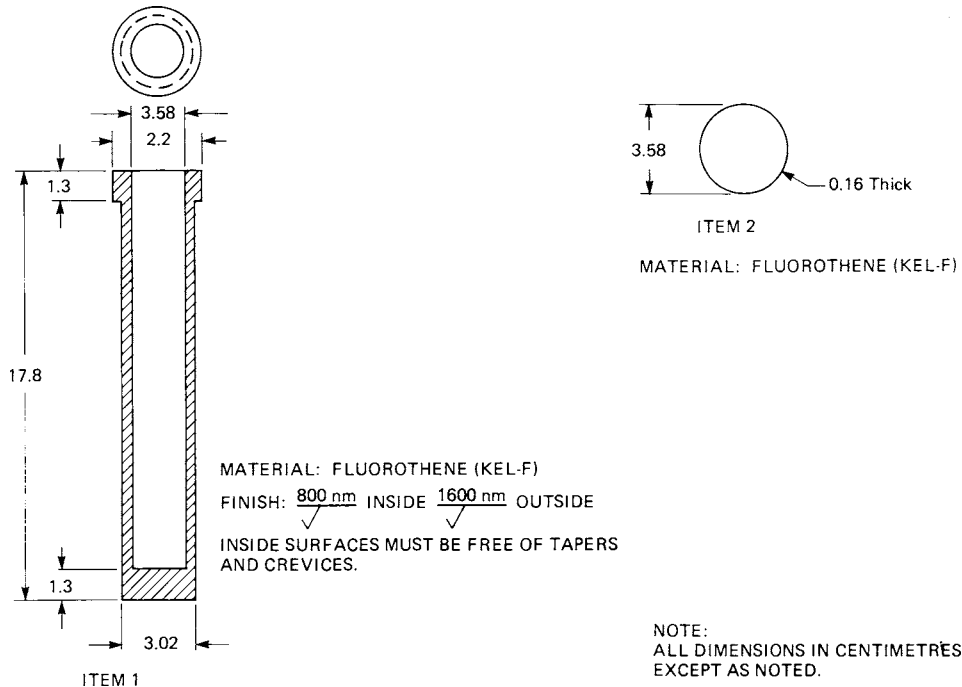

FIG. 3 Polychlorotrifluoroethylene Knockout Cylinder

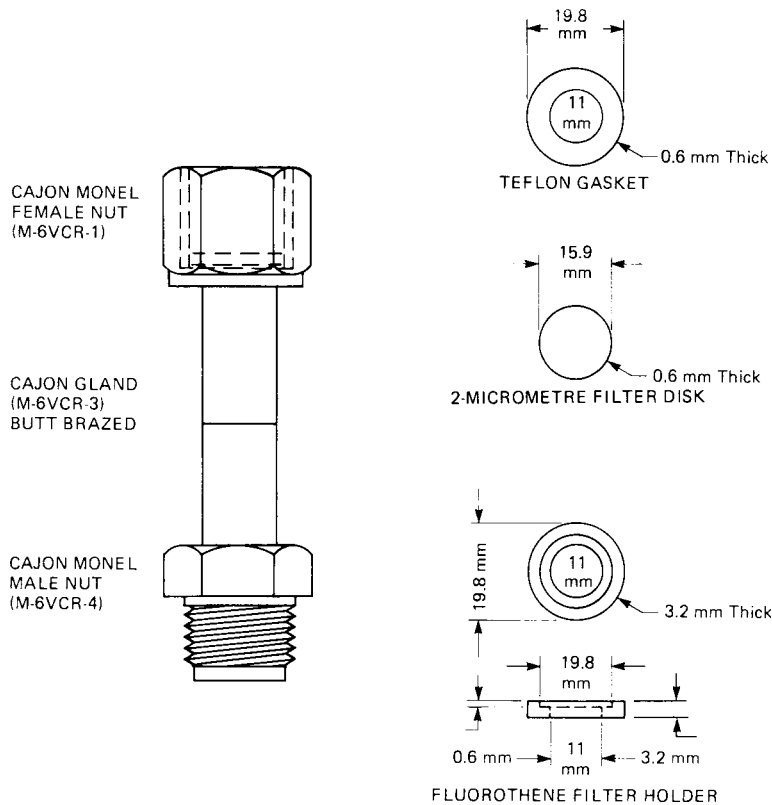

FIG. 4 Filter Disk Unit

10.2.10 Open Valves 3 and 4, and admit dry nitrogen or dry air until a pressure slightly above 1 atm is reached.

10.2.11 Disconnect the polychlorotrifluoroethylene tube, seal with a polychlorotrifluoroethylene gasket and a Monel plug, and weigh the tube assembly.

10.2.12 Cap the manifold port and close Valves 2 and 4.

10.2.13 For metals, halogens, or isotopic analysis, proceed to the hydrolysis of the UF₆.

10.2.13.1 Prepare chilled distilled water. Pour the water into a clean 500 mL polyethylene bottle. Use this water to prepare a solution of 0.1gU/g of solution.

10.2.13.2 Cool the polychlorotrifluoroethylene tube in liquid N₂ for 15 minutes. Remove the metal fittings and drop the tube in the water.

10.3 *Sample Transfer to a gaseous Isotopic Abundance Tube:*

10.3.1 Open Valves 1, 3, and 5, as well as the isotopic abundance tube valve, to evacuate the tube.

10.3.2 Close Valves 1, 2, and 3.

10.3.3 Immerse the lower half of the metal isotopic abundance tube, as shown in Fig. 1, in liquid nitrogen for 1 or 2 min. Immerse plastic tubing in ice water and observe desublimed UF₆.

10.3.4 Remove the liquid nitrogen or ice water and allow frost to accumulate on the tube.

10.3.5 Open the bulk-container valve and then close.

10.3.6 Open Valve 1 slowly, and observe melting of the frost as the UF₆ flows into the tube. As soon as the frost disappears, close the isotopic abundance tube valve.

10.3.7 Open Valve 3 to remove the UF₆ from the manifold.

10.3.8 Close Valve 5 and open Valve 4 to admit dry nitrogen or dry air until a slight positive pressure is reached. Then close Valve 4.

10.4 *Sample Preparation for Soluble and Insoluble Chromium in UF₆:*

10.4.1 Attach the porous nickel filter unit with a weighed 2- μ m filter, as shown in Fig. 4, to the bottom port of the vacuum manifold, and attach a tared polychlorotrifluoroethylene tube to the bottom of the filter unit.

10.4.2 Transfer 15 to 20 g of liquid UF₆ through the filter to the polychlorotrifluoroethylene sample tube, as in 10.2.3 through 10.2.12.

10.4.3 Remove the porous nickel filter and dissolve it in 10 mL of 1.42 sp gr HNO₃.

10.4.4 Submit the dissolved filter solution for analysis of chromium insoluble in UF₆ and the filtered UF₆ in the polychlorotrifluoroethylene sample tube for chromium soluble in UF₆.

10.5 *Sample Transfer to polychlorotrifluoroethylene Knockout Cylinder:*

10.5.1 Attach the polychlorotrifluoroethylene knockout cylinder, as shown in Fig. 3, to the bottom port of the manifold with a Cajon M-16 VCR-1 female nut, an M-16 VCR-4 male nut, and an M-16 VCR-3 gland.

10.5.2 Transfer approximately 50 to 200 g of liquid UF₆ to a tared polychlorotrifluoroethylene knockout cylinder, as in 10.2.3 through 10.2.12, except that in 10.2.7, the knockout cylinder is immersed in liquid nitrogen for 15 min.

10.5.3 Allow the knockout cylinder to warm to ambient temperature and then weigh to the nearest gram.

10.5.4 Freeze the knockout cylinder in liquid nitrogen for 15 min, and remove the metal fittings and cover gasket. Transfer the sample to a tared, 2-L polypropylene beaker chilled in ice water, by inverting the knockout cylinder over the beaker and rapping the bottom of the knockout cylinder with a rubber mallet.

10.5.5 Immediately add chilled distilled water, to form a solution of approximately 0.1 g U/g of solution.

10.5.6 Allow the solution to reach ambient temperature while stirring periodically with a polypropylene stirring rod until all of the solid has dissolved.

10.5.7 Weigh the solution and determine the uranium concentration per gram of solution.

10.5.8 Dispense aliquots of the solution for analysis according to Table 1.

10.6 *Sample Transfer for All Gas Carbon Determination:*

10.6.1 Attach a 2S cylinder to the fitting for the spectrometer isotopic abundance tube (Table 1).

10.6.2 Open Valves 1, 3, and 5 and the gas sample cylinder valve, and evacuate the manifold and sample cylinder.

10.6.3 Close Valve 3.

10.6.4 Slowly open the bulk-sample container valve to admit UF₆ until a pressure of 25 mm is reached in the sample cylinder. Close the bulk-sample container valve.

10.6.5 Open Valve 3 and evacuate the manifold and sample cylinder.

10.6.6 Close Valve 3.

10.6.7 Slowly open the bulk-sample container valve to admit UF₆ until a pressure of 75 mm is reached in the sample cylinder.

10.6.8 Close the gas sample cylinder valve and open Valve 3 to evacuate the manifold.

10.6.9 Close Valve 5, open Valve 4, to bring the manifold to atmospheric pressure and remove the bulk-sample container from the manifold.

10.6.10 Plug the bulk-sample container port on the manifold, close all valves, and remove the gas sample cylinder.

10.7 *Total UF₆ Gas Transfer:*

10.7.1 Immerse the bottom of the Knockout cylinder in liquid nitrogen for 15 min.

10.7.2 Close valve 3 and 5 and then open the bulk container valve. The pressure will increase due to the flow the UF₆ being drawn into the manifold.

10.7.3 Wait until the pressure drops back to its original value, which will indicate a total transfer of the gaseous UF₆ in the knockout cylinder.

NOTE 2—If the pressure does not drop, it may be due to frozen UF₆ in the top of the knockout cylinder. In that case remove the liquid nitrogen from the knockout cylinder and heat the knockout cylinder until the UF₆ drops. Replace the liquid nitrogen container

10.7.4 Close valve 2 and open valves 3 and 5 to evacuate the UF₆ in the manifold. Open valve 4 to fill manifold with N₂.

10.7.5 Disconnect and weigh the UF₆ bulk container. Compare the tare weight in order to ensure that a total UF₆ transfer was performed from the mother container to the knockout cylinder. If not, reconnect the mother container and proceed from 10.7.2.

10.7.6 Proceed according to 10.5.4 to hydrolyse the UF₆ in the knockout cylinder.

GRAVIMETRIC DETERMINATION OF URANIUM

11. Scope

11.1 Test method C 1346 is applicable to the hydrolysis of uranium hexafluoride in polychlorotrifluoroethylene (P10)

tubes. The following test method is then applicable to the direct gravimetric determination of uranium.

12. Summary of Test Method

12.1 A sample of uranium hexafluoride is weighed, cooled in liquid nitrogen, and hydrolyzed with water. The uranyl fluoride solution produced is evaporated to dryness and converted to uranouranic oxide by pyrohydrolysis. The uranium content is determined from the weight of the uranium oxide after correcting for stoichiometry based on isotopic content, ignition conditions, and nonvolatile impurities (4-7).

13. Interferences

13.1 Nonvolatile impurities affect the accuracy of the method and must be measured by spectrographic analysis with corrections applied.

14. Apparatus

14.1 *Polytrifluorochloroethylene (TFCE) Sample Tube, TFCE Gasket, Flare Nut, and Plug*, see Fig. 2.

14.2 *Platinum Boat and Cover*—The cover should be platinum gauze (52 mesh) and shaped to cover the boat (Fig. 5).

14.3 *Muffle Furnace*, must be capable of operating continuously at 875°C and maintain this temperature within ±25°C. The furnace shall be equipped with a steam supply that is passed through a tube furnace to preheat the steam to 875°C.

14.4 *Tube Furnace*, must be capable of operating continuously at 875°C and maintain this temperature within 25°C.

14.5 *Infrared Heat Lamps*, 250 watts.

14.6 *Analytical Balance*.

14.7 *Vacuum Oven*.

14.8 *Dewar Flask*, stainless steel.

14.9 *Spatula*, platinum.

14.10 *TFCE Rod*, 120 mm long and 1.6 mm in diameter.

14.11 *Forceps*, platinum tipped.

14.12 *Jig*, suitable for holding the TFCE sample tube so that it can be opened with a wrench.

14.13 *Box Wrench*, to fit sample tube plug.

14.14 *Beaker*, stainless steel, 125 mL capacity.

15. Reagents

15.1 *Liquid Nitrogen*.

15.2 *Nitric Acid (sp gr 1.42)*—concentrated nitric acid (HNO₃).

15.3 *Nitric Acid (4M)*—Mix 500 mL of concentrated HNO₃ with 1500 mL of distilled water.

15.4 *Detergent*.

16. Sampling

16.1 A UF₆ sample is taken as described in 9.2.

17. Procedure

17.1 Inspect the TFCE sample tube for leaks.

NOTE 3—An indication of a leak is a yellow-green residue on the flare nut and cap or a yellow discoloration in the tube. Discard the sample if a leak is indicated.

17.2 Allow the sample tube to stand overnight in the laboratory.

17.3 Wipe the sample tube with a lint-free tissue to remove any moisture or foreign material that might be adhering.

17.4 Weigh the sample tube to the nearest 0.1 mg.

17.5 Heat the platinum boat and screen in the pyrohydrolysis furnace at 875°C for 20 min.

17.6 Cool the platinum boat and store in a desiccator for 40 min. Weigh the boat and screen to the nearest 0.1 mg.

17.7 Freeze the sample by immersing the sample tube in liquid nitrogen for 10 min.

17.8 Add enough chilled water to the tared platinum boat to immerse the sample tube (about 50 mL).

17.9 Place the sample tube in the jig and loosen the plug with the box wrench.

17.10 Remove the sample tube from the jig and unscrew the plug while holding the sample tube in an upright position.

17.11 Remove the flare nut from the sample tube and immerse the tube and gasket in the chilled water in the tared platinum boat.

17.12 Let the gasket remain in the chilled water about 30 min.

17.13 Remove the gasket with the forceps and rinse well with deionized water into the boat.

17.14 Place the plug-nut assembly and gasket into a stainless steel beaker for drying.

17.15 Allow the tube to remain in the water until the UF₆ has been hydrolyzed (2 to 4 h).

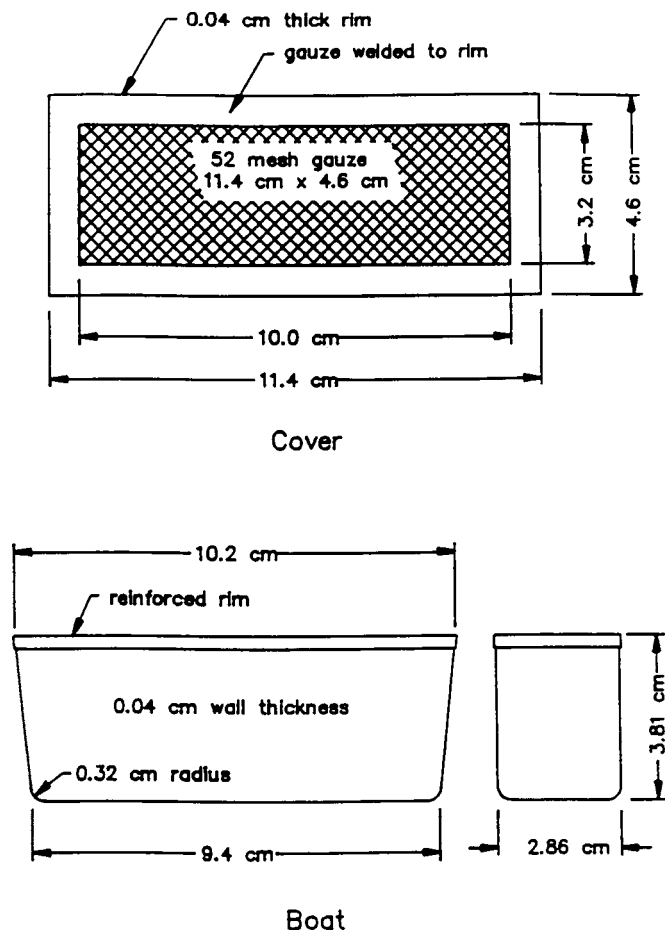

FIG. 5 Platinum Boat and Cover

17.16 Remove the tube from the sample solution by inserting the TFCE rod or platinum spatula into the tube and lifting directly above the boat.

17.17 Rinse the sample tube with deionized water into the boat using extreme care to prevent splashing.

17.18 Cover the sample boat containing the UO_2F_2 solution with the matching cover shown in Fig. 5. Place under the infrared head lamps and evaporate to dryness for 16 h.

17.19 Shake the excess water from the sample tube and place in the stainless beaker containing the plug-nut assembly and gasket.

17.20 Dry the sample tube parts in the vacuum oven at 80°C and 29 in Hg for 2 h.

17.21 Allow the unassembled parts to sit in the room overnight.

17.22 Assemble the empty sample tube and weigh to the nearest 0.1 mg.

17.23 Disassemble the sample tube and soak the tube and gasket in 4M HNO_3 at 75° to 80°C for 1 h.

17.24 Rinse with deionized water and place in the stainless steel beaker.

17.25 Clean the metal parts with detergent and rinse with deionized water and acetone.

17.26 Place the metal parts to the stainless steel beaker and dry all parts in the vacuum oven at 80°C and 29 in Hg overnight.

17.27 Reassemble the sample tube for the next sample.

17.28 Set the temperatures of the furnace and tube furnace at 875°C .

17.29 Establish a steam flow to the furnace equal to 1 L of water per hour.

17.30 Place the boat into the furnace with the platinum cover on the boat and pyrohydrolyze the sample for 1 h.

17.31 Remove the boat from the furnace, cool, and place in a desiccator while still warm.

17.32 Desiccate the sample for 1 h and weigh quickly to the nearest 0.1 mg.

17.33 Transfer a portion of the U_3O_8 residue to a vial and submit for spectrographic analysis to determine the weight of nonvolatile impurities.

17.34 Place the platinum boat in hot 4M HNO_3 for 3 to 4 h and rinse with deionized water acetone.

18. Calculation

18.1 Calculate the weight fraction of uranium in the sample as follows:

$$\text{gU/g UF}_6 = (A - (AB))(\text{Gravimetric Factor})/W \quad (1)$$

where:

Gravimetric Factor = gU/g U_3O_8 which varies with isotopic composition. Theoretical stoichiometry for U_3O_8 cannot be assumed and the actual gU/g U_3O_8 must be established by potentiometric titration (4–7). (Tri-diffusion plant committee with DOE approval has established 0.8479 g U/g U_3O_8 by titration as the factor for natural uranium,

A = grams of U_3O_8 from the pyrohydrolysis of UO_2F_2 ,

B = grams of impurity metal oxides per gram of U_3O_8 ,

W = corrected sample weight in grams.

The correction is for the combined effects of cover gas trapped over the UF_6 in the sample tube and the air buoyancy correction (8). The following equation has been determined for the sample tube in Fig. 2 and the subsampling conditions described in 10.2. The correction equation is applicable for sample weights in the range of 7 to 13 g.

$$W = (1.00047)x - 0.0058 \quad (2)$$

where:

x = observed UF_6 sample weight, g.

19. Precision and Bias

19.1 *Precision*—The precision within a laboratory and between laboratories was established by analyzing 15 samples at each laboratory. The sampling scheme is shown in Table 2. Within a laboratory, based on 15 measurements made on separate days the relative standard deviation is 0.021 %. The results from all the laboratories are shown in Table 3.

19.2 *Bias*—To establish an estimate of bias for the gravimetric method, a series of comparative analyses of UF_6 control batches were made using the gravimetric and potentiometric titration methods. The potentiometric titration was used as the reference method because the uranium was measured directly using NIST potassium dichromate.¹⁰ The results are shown in Table 4.

TITRIMETRIC DETERMINATION OF URANIUM

20. Scope

20.1 A sample of the U_3O_8 produced by the hydrolysis of the UF_6 and ignition of the resulting UO_2F_2 is analyzed according to Test Method C 1267.

¹⁰ Standard reference material, now available as NIST SRM 136e.

TABLE 2 Interlaboratory Study^A—Determination of Uranium in Uranium Hexafluoride

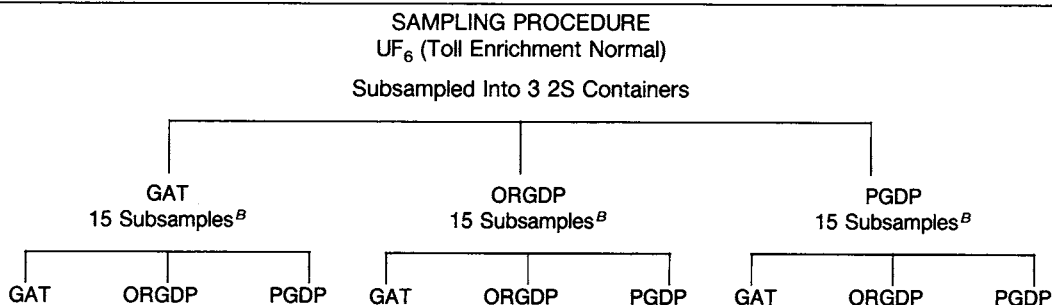

^A Date of study—October 1983; Participating laboratories—Goodyear Atomic Corporation, Portsmouth, Ohio (GAT); Martin Marietta Energy Systems, Inc., Oak Ridge, Tennessee (ORGDP); Martin Marietta Energy Systems, Inc., Paducah, Kentucky (PGDP).
^B Five tubes analyzed at each laboratory.

TABLE 3 Results of Interlaboratory Study—U in UF₆

Analysis Site %U in UF ₆		
GAT	ORGDP	PGDP
<i>Subsampled at GAT:</i>		
67.600	67.619	67.589
67.601	67.574	67.575
67.583	67.607	67.612
67.611	67.600	67.612
67.618	67.606	Sample Lost
<i>Subsampled at ORGDP:</i>		
67.614	67.580	67.611
67.611	67.621	67.598
67.587	67.600	67.501
67.599	67.606	67.610
67.617	67.596	67.624
<i>Subsampled at PGDP:</i>		
67.616	67.588	67.591
67.586	67.602	67.620
67.573	67.612	67.612
67.614	67.606	67.612
67.607		67.586
<i>Mean and Standard Deviation:</i>		
67.602 ± 0.014	67.601 ± 0.013	67.603 ± 0.014

PREPARATION OF HIGH-PURITY U₃O₈

21. Scope

21.1 High purity U₃O₈ can be prepared according to Preparation C 1128. High purity uranium is needed for a blank matrix for analyses using ICP-MS, ICP-AES, AA, XRF, and MS equipment.

ISOTOPIC ANALYSIS

22. Scope

22.1 The isotopic composition can be determined on either gaseous UF₆ or on hydrolyzed UF₆.

22.2 For gaseous UF₆, a double standard single collector mass spectrometer method can be used (see sections 23 to 28). Test method C 1344 using single standard single collector mass spectrometer can also be used. For multi-collector instruments, test methods C 1428 and C 1429, using single or double standard can be used.

22.3 For hydrolyzed UF₆, methods using Thermal Ionization Mass Spectrometry (TIMS) have been developed and can be used: test methods C 1413 and C 1380. Methods using ICP-MS can also be used depending on the required specifications: test methods C 1474 and C 1477.

ISOTOPIC ANALYSIS BY DOUBLE-STANDARD MASS-SPECTROMETER METHOD

23. Scope

23.1 This test method is applicable to the determination of the isotopic composition of UF₆ samples. The test method as described is specific for the direct determination of the ²³⁵U concentration of UF₆ samples having a ²³⁵U content of 60 mol % or less. However, the test method is equally appropriate for the direct determination of any of the isotopes of uranium of any enrichment when suitable UF₆ isotopic standards are available. This test method is designed to minimize all known sources of analytical bias.

24. Summary of Test Method

24.1 The unknown sample and two standards whose ²³⁵U contents bracket that of the unknown are introduced in sequence into the mass spectrometer, and measurements are made which are a function of the mol ratio of ²³⁵U to the total of the other isotopes of uranium. These measurements together with the known composition of the standards permit calculation of the ²³⁵U composition of the sample by linear interpolation (11 to 16).

24.2 The symmetrical, 6-entry sequence of sample-standard introductions is designed to minimize biases resulting from instrument drift, sample interaction or memory, and the non-linearity of the relationship between the measured resistance ratios and the true sample mol ratios. Corrections generally are not required for instrument memory.

25. Apparatus

25.1 *Mass Spectrometer* with the following features and capabilities (12, 14, 17):

TABLE 4 Determination of Uranium in Uranium Hexafluoride—Comparison of Gravimetric and Potentiometric Titration Methods

Control UF ₆ Date ^A	Method	Number of Measurements	%Uranium		Bias Estimate ^B
			Mean	SD	
9/78	Gravimetric	24	67.610	0.009	-0.001
	Potentiometric Titration	9	67.611	0.015	
5/82–8/82	Gravimetric	30	67.596	0.010	-0.009
	Potentiometric Titration	8	67.605	0.011	
7/83–9/83	Gravimetric	25	67.610	0.006	+ 0.005
	Potentiometric Titration	8	67.605	0.010	

^AControl UF₆ used in 9/78 was a different batch of material from that used in 1982 and 1983.

^BPotentiometric titration results are used as the reference values for the bias estimates.

25.1.1 The instrument must have an electron bombardment ion source having an efficiency such that a sample flow rate of about 0.03 std ml of UF₆/h will result in a total ion current for UF₅⁺ ions of approximately 10⁻⁹ A.

25.1.2 The sample inlet system must have a minimum of three points for attachment of samples, the necessary valves to evacuate the sample lines and admit the UF₆ into the ion source, and a variable leak to control the flow of UF₆ into the ion source.

25.1.3 A dual ion collector (18) must be used. The first detector, called the high-current collector, contains a central slit, preferably adjustable, to permit passage of 95 to 100 % of the ions of the ²³⁵U isotope (mass 330). This detector intercepts ions of the other isotopes of uranium within a mass range of about 1.5 % of mass 330. The ²³⁵U ions passing through the slit are intercepted by a second detector, called the low-current collector.

25.1.4 The measuring system must provide a precise null-balance measurement of the ratio of the ion signals from the low-current and high-current detectors. Such a system usually consists of two electrometer amplifiers, a constant-impedance ratio decade, a ratio recorder or two amplifiers, and a digital ratiometer. The sensitivity of the system should be such that a change of 1 × 10⁻¹⁵ A ion current can be detected. An attenuation range of at least a factor of 100 should be provided for the low-current amplifier. If ²³⁵U concentrations greater than 60 mol % are to be determined directly, a switch must be provided to reverse the amplifier leads to the ratio decade panel, and a similar attenuation range must be provided for the high-current amplifier. For those measurements the ²³⁵U still passes through the slit, but the measurement is now a function of the ratio of the other isotopes to the ²³⁵U isotope.

25.1.5 The resolving power of the instrument should be such that the ²³⁵UF₅⁺-²³⁸UF₅⁺ valley height should be less than 3.0 % of the ²³⁵UF₅⁺ peak height after the peak height has been normalized. The normalization consists of dividing the observed peak height by the sample ²³⁵U concentration, expressed as a percentage. This resolution requirement should be met with the collector slit width adjusted to pass at least 95 % of the ²³⁵U ion beam.

25.1.6 If the concentrations of the minor isotopes, ²³⁴U and ²³⁶U, are to be measured, the ²³⁴UF₅⁺-²³⁵UF₅⁺ valley should be less than 50 % of the ²³⁴UF₅⁺ peak height. To meet this requirement it will be necessary to narrow the collector slit width and reduce the ion beam transmission to 70 to 80 %.

26. Procedure

26.1 Sample Preparation:

26.1.1 A bias will be introduced into the analysis if impurities are present in the vapor phase of the sample or either standard. Prepare the UF₆ sample containers for the analysis as follows:

26.1.1.1 Attach the sample and standard containers to the sample inlet system. The low standard, *A*, should have a ²³⁵U concentration lower than that of the sample, *X*, and the high standard, *B*, should have a concentration higher than the sample. The ratio of mol ratios of the standard pair should be about .

26.1.1.2 Open the appropriate valves to evacuate the sample lines of the inlet system.

26.1.1.3 After the system has been evacuated, open the valve on the sample container and then close quickly to vent the gas phase of the sample to the pumping system.

26.1.1.4 After the pumping system has had sufficient time to evacuate the vented gases, repeat 26.1.1.3.

26.1.1.5 Repeat 26.1.1.3 and 26.1.1.4 separately for the *A* and *B* standard containers.

26.1.1.6 Admit the *B* standard through the variable leak into the ion source for about 15 s, observe the ion source pressure, and remove the sample from the source.

26.1.1.7 Repeat 26.1.1.6 for the sample and for the *A* standard.

26.1.1.8 If the source pressure readings are the same, the samples are ready for the analysis (see 26.2).

26.1.1.9 If a high pressure is observed for one of the samples, immerse the sample container in a mixture of trichloroethylene and dry ice; open the container valve; and pump off the volatile impurities.

26.1.1.10 Close the container valve, allow the sample to reach ambient temperature, and repeat 26.1.1.6. If the source pressure reading is the same as the other samples, the samples are ready for the analysis (see 26.2).

26.1.1.11 If the pressure is still high, liquefy the UF₆ by heating the sample container to 70°C; then open the valve on the container and close quickly to vent the gas phase to the pumping system.

26.1.1.12 After the pumping system has had sufficient time to evacuate the vented gases, repeat 26.1.1.6. If necessary, repeat 26.1.1.9 or 26.1.1.11, or both, until no increase in pressure is observed.

26.2 Instrument Preparation:

26.2.1 Prepare the instrument for the analysis as follows:

26.2.1.1 Operate the appropriate valves to admit the low standard, *A*, through the variable leak into the ion source.

26.2.1.2 Adjust the mass spectrometer high voltage or magnet current, or both, to focus the UF_5^+ ions on the upper detector plate.

26.2.1.3 Make a fine adjustment of the high-voltage or magnet current to focus the ^{235}U ion beam (for samples containing 60 mol % ^{235}U or less) of the UF_5^+ ion group through the slit to the lower detector plate, while the other ions of the UF_5^+ ion group are focused on the upper collector plate. This step, known as *peaking up*, is completed when the signal for the low-current collector plate is maximized.

26.2.1.4 Adjust the variable leak so that the flow of UF_6 into the ion source produces the desired signal for the ions striking the upper collector plate. This ion current should be equivalent to approximately 10^{-9} A.

26.2.1.5 Operate the valves to remove the flow of the A standard from the ion-source region, and evacuate the region for a period of 1 min or more.

26.3 Mass Spectrometer Measurements:

26.3.1 The sequence for the analytical determination during which the actual measurements are made is as follows: A, X, B, B, X, A, where A, X, and B represent a constant, precisely timed introduction of Standard A, Sample X, and Standard B, respectively. Each introduction is followed by a somewhat shorter, but precisely timed, period during which there is no flow of sample or standard material into the ion source. During each introduction of UF_6 into the ion source, perform the following operations:

26.3.1.1 Regulate the intensity of the ions striking the upper collector plate to the desired level, and within as close a tolerance range as can be attained, by adjusting the variable leak to control the sample flow.

26.3.1.2 Adjust the high-voltage or magnet-current fine control to maximize the low-current detector signal; maintain the adjustment at this maximum value for the remainder of the timed introduction period, or sweep repeatedly across this maximum reading to obtain a series of scans of the peak maxima during the remainder of this period.

26.3.1.3 With the instrument peaked up, or while scanning the peak, obtain a reading while the electrometers for the two detecting plates are connected in a null-type measuring circuit. This reading is a function of the ratio of the number of ions striking the lower detector plate to the total number of ions striking the upper plate. Use only the data taken during the last half of the timed introduction period.

26.3.1.4 For each analytical sequence of A, X, B, B, X, A, obtain six ratio values, two for each standard and two for the sample. Average the two values obtained for each standard and the sample to obtain three ratio values designated R_A , R_X , and R_B for each A, X, B, B, X, A sequence.

26.3.1.5 For samples in which the ^{235}U content is greater than 60 mol %, reverse the amplifier leads to the ratio decade to obtain a null-balance measurement. The measurements are then a function of the ratio of the number of ions other than ^{235}U to the number of ^{235}U ions. As an alternative procedure, make the focus in 26.2.1.3 on the ^{238}U ion beam instead of the ^{235}U ion beam. This procedure will result in the determination of the weight percent ^{238}U . To determine the ^{235}U content, determine the minor isotopes independently, and subtract the

sum of the weight percent ^{238}U and the weight percent of the minor isotopes from 100 to obtain the weight percent ^{235}U .

26.3.1.6 The small residual bias associated with this test method is no larger than ± 0.02 , and even this may be corrected by making end-point determinations. The end-point controls are additional measurements with one of the standards, A or B, substituted for the unknown in the analytical sequence. Thus, for an end-point measurement, follow one of the sequences A, A, B, B, A, A, or A, B, B, B, B, A, and use the results to make corrections for residual bias in the measurements on the unknown.

27. Calculation

27.1 For uranium having a concentration of 50 mol % ^{235}U or less, calculate the weight percent ^{235}U as follows:

27.1.1 Calculate the ratio of differences, R_D , as follows:

$$R_D = (R_X - R_A)/(R_B - R_A) \quad (3)$$

where:

R_X = average reading for sample entries,

R_A = average reading for low-standard entries, and

R_B = average reading for high-standard entries.

27.1.2 Calculate the sample weight ratio, H_X , using the linear interpolation, as follows:

$$H_X = R_D (H_B - H_A) + H_A \quad (4)$$

where:

H_X = weight ratio of ^{235}U to other isotopes in the sample,

H_A = weight ratio of ^{235}U to other isotopes in the low standard,

H_B = weight ratio of ^{235}U to other isotopes in the high standard, and

R_D = value from Eq 3

27.1.3 Calculate the weight percent ^{235}U (U_5) in the sample as follows:

$$U_5 = 100 H_X / (100 + H_X) \quad (5)$$

27.2 For samples having a ^{235}U concentration greater than 60 mol %, reverse the amplifier leads to the ratio decade, and obtain reciprocal readings which are a function of the ratio of the mols of other isotopes to the mols of ^{235}U . Calculate the weight percent ^{235}U as follows:

27.2.1 Calculate the ratio of differences, R_D , using Eq 1.

27.2.2 Calculate the reciprocal of the weight ratio, H_X , from the relationship:

$$1/H_X = R_D [(1/H_B) - (1/H_A)] + 1/H_A \quad (6)$$

27.2.3 Calculate the weight percent ^{235}U in the sample, using Eq 5.

27.3 As an alternative method of analyzing samples having concentrations greater than 60 mol % ^{235}U , determine the weight percents ^{238}U , ^{234}U , and ^{236}U . In each case pass the isotope of interest through the collector slit, and obtain measurements for the sample and the two bracketing standards. Use these measurements together with the known composition of the standards to calculate the sample composition by linear interpolation (Eq 4). The standard values used in the calculations are the weight ratios of ^{238}U to the other isotopes, ^{234}U to the other isotopes, or ^{236}U to the other isotopes. Obtain the ^{235}U composition by difference.

27.4 To correct for the small residual bias, intersperse analytical sequences in which each standard is treated as the sample with the sample-analysis sequences. The number of standard sequences should be about 10 % of the number of sample sequences. Run one half of the standard sequences as A, A, B, B, A, A and the other half as A, B, B, B, B, A. Designate the ratio values from these sequences R_A , R_{AX} , and R_B ; and R_A , R_{BX} , and R_B . Correct the sample R_D values in the following manner:

27.4.1 Calculate the end-point biases, R_{DA} and R_{DB} , from Eq 7 and Eq 8:

$$R_{DA} = (R_{XA} - R_A)/(R_B - R_A) \quad (7)$$

$$R_{DB} = (R_{XB} - R_A)/(R_B - R_A) \quad (8)$$

27.4.2 Calculate two correction factors, F_1 and F_2 , from Eq 9 and Eq 10:

$$F_1 = 1/(R_{DB} - R_{DA}) \quad (9)$$

$$F_2 = R_{DA}(R_{DB} - R_{DA}) \quad (10)$$

27.4.3 Then correct the sample R_D values as follows:

$$R_{DT} = F_1 R_D - F_2 \quad (11)$$

28. Reliability

28.1 The following tabulation shows the percent limit of error, at the 95 % confidence level, for a single determination which has been obtained using the method described.

Difference Between Standards, %	Limit of Error, %	
	Routine	Special
5	0.04	...
15	0.06	0.01
30	0.08	0.01
45	0.10	...

28.2 These values are based on thousands of determinations on a variety of UF_6 samples during a 10-year period. Single-focusing, 152-mm radius, 60-deg deflection mass spectrometers were used.

28.3 Routine precision is obtained without end-point corrections and without special emphasis on instrument stability or limitations on isotopic concentrations analyzed on a given instrument. Greater selectivity with respect to instrument stability, resolving power, and other operating characteristics, as well as limitation of the isotopic range of samples exposed to the instrument and end-point corrections, are required to achieve the special precision quoted.

DETERMINATION OF HYDROCARBONS, CHLOROCARBONS, AND HALOHYDROCARBONS

29. Scope

29.1 The determination of hydrocarbons, chlorocarbons, and halo-hydrocarbons in UF_6 vapour can be performed using C 1441. As an alternative, a mass spectrometry technique may be used and is detailed below. Although this test method is only semiquantitative, it is adequate for certifying that the subject impurities do not exceed 0.01 mol % of the UF_6 .

30. Summary of Test Method

30.1 UF_6 is admitted to a mass spectrometer through a gas sample leak, and magnetic scanning is employed to record a

spectrum of peaks. A representative group of recorded peaks is compared to the same peaks in a pure UF_6 standard scan to determine whether appreciable ion fragments from subject impurities are present.

31. Interferences

31.1 If detectable impurities are present, a complete mass scan of the range from 12 to 400 is performed. All impurities are then identified from their cracking patterns, and calculations are performed using ionization efficiency factors for the compounds present. Since cracking patterns vary with ionization potential and ionization efficiencies vary with focus conditions, this measurement can only be performed by one proficient in analytical mass spectrometry.

32. Apparatus

32.1 A mass spectrometer with resolution adequate to distinguish between adjacent peaks at $m/e = 400$ is required. For example, a 152-mm radius, 60-deg, Nier-type spectrometer modified for spectrum recording (22) is suitable. The sample inlet system should be of nickel or Monel, equipped with an adjustable viscous-flow or molecular leak for delivering the sample to the ion source.

32.2 The ion source must be fabricated from nonmagnetic material such as Nichrome V, and must be designed so it can be disassembled for cleaning. The magnetic field of the analyzer magnet must be continuously variable from about 200 to 6500 gauss. A single ion collector electrode is suitable, and a vibrating-reed electrometer and 304-mm strip chart recorder are optimum for amplifying and recording ion signals.

32.3 It is quite possible that quadrupole or time-of-flight instruments could be adapted to this measurement.

33. Procedure

33.1 UF_6 Standard Measurements:

33.1.1 Select a standard material that has been given repetitive flash purifications to rid it of all volatile impurities. Isotopic UF_6 standards usually fall in this category.

33.1.2 With the electrometer sensitivity set at $1/100$ of the most sensitive usable operating range, adjust the gas flow to the ion source to record a mass (Note 4) 333 peak (UF_5^+) approximately 80 % of full scale (80 divisions).

NOTE 4—The term “mass” in this procedure alludes to m/e , the mass-to-charge ratio.

33.1.3 Measure the ratio of mass 333 (UF_5^+) to 147.5 (UF_3^{++}). Mass 333 is measured on a sensitivity range one-hundredth that of mass 147.5. Depending on focus conditions, a ratio of the order of 10^2 is obtained. Measure this ratio only once per day and use for calculating results of all samples analyzed that day.

33.1.4 With the electrometer sensitivity set at $1/100$ of the most sensitive usable operating range, increase the gas flow to provide an output signal of approximately 80 divisions at the 147.5 mass position. This gives a detectability limit of the order of 2 ppm per chart division: 50 to 100 due to ratio between UF_5^+ and UF_3^{++} , 100 due to sensitivity shunts, and approximately 80 on the recorder chart.

33.1.5 Record a scan of mass range from 12 to 150 using the most sensitive usable operating shunt, and use this scan as a background for all samples analyzed that day.

33.2 UF_6 Sample Measurement:

33.2.1 Introduce the sample to the spectrometer source such that an output intensity of approximately 80 chart divisions is obtained at the 147.5 mass number (UF_3^{++}), using $\frac{1}{100}$ the most sensitive usable operating range.

33.2.2 Record a scan of mass range from 12 to 150 using the most sensitive usable operating range.

33.2.3 Repeat 33.2.1 and 33.2.2 for each sample to be analyzed that day.

34. Calculation

34.1 Due to mass spectrometer cracking patterns, low-mass ion fragments are produced from all compounds, even the high-mass ones.

34.2 It is practical to look for a representative group of such ion fragments at specific masses. Thus, initially monitor the following masses for purposes of this procedure:

Mass Number	Positively Charged Ion Fragment
15	CH_3
26	C_2H_2
27	C_2H_3
31	CF
43	C_3H_7
47	CCl^{35}
49	CCl^{37}
69	CF_3

34.3 Read sample intensities for the representative ion fragments from the recorder chart.

34.4 Subtract the background intensities observed on the pure standard from respective sample intensities.

34.5 Examine the net intensity at each of the eight mass numbers. (It will be recalled that one recorder chart division of net intensity is equivalent to about 2 ppm on a UF_6 basis; however, ionization efficiencies of compounds differ, and a specific ion fragment may result from many different compounds. Thus, the net intensity at a specific mass number is only qualitative and not a quantitative measurement of impurity.)

34.5.1 If the net ion intensity does not exceed 2 ppm at any of the mass positions, report the sample as containing less than 0.01 mol % of the subject impurities.

34.5.2 Where detectable impurities are apparent, perform a complete mass scan of the range from 12 to 400, identify impurities, and perform calculations using ionization efficiency factors for the compounds present.

35. Reliability

35.1 This simplified procedure was designed specifically to certify that a UF_6 sample contains less than 0.01 mol % hydrocarbons, chlorocarbons, and partially substituted halo-hydrocarbons. Thus, the procedure is qualitative rather than quantitative in cases where the impurity level is below 100 ppm.

35.2 The detectability limit for any ion fragment is about 2 ppm. The detectability limit for the parent compound could be greater or less than 2 ppm depending on ionization efficiency and cracking pattern. If one of the subject compounds were

present to 10 ppm or more, it would be evident from monitoring the eight masses. Thus, a quoted result of less than 0.01 mol % is conservative.

35.3 The results are considered quantitative when the impurity being determined is present to a level greater than 100 ppm. In such instances the impurity is identified and measured. The 95 % symmetrical confidence interval for such a measurement is ± 50 % of the quoted impurity.

DETERMINATION OF ANTIMONY

36. Scope

36.1 The Atomic Absorption test method has been discontinued (see C 761–96). Antimony can be determined by ICP-MS. Test Method C 1287 can be used.

DETERMINATION OF BROMINE

37. Scope

37.1 The Spectrophotometric test method has been discontinued (see C 761–96). Bromine can be determined by X-Ray spectroscopy. Test Method C 1508 can be used.

DETERMINATION OF CHLORINE

38. Scope

38.1 Chlorine can be determined by X-Ray Spectroscopy. Test Method C 1508 can be used. Chlorine can also be determined by titrimetry. This test method is described below. It is applicable over a range from 10 to 100 ppm chlorine; however, higher concentrations can be measured by appropriate sample dilution.

39. Summary of Test Method

39.1 The test method consists of treating a hydrolyzed sample of UF_6 with ferrous sulfate in sulfuric acid solution to reduce chlorates, and then with potassium permanganate to liberate free chlorine. The chlorine gas is carried by a nitrogen stream into a potassium iodide solution, and the liberated iodine is titrated with sodium thiosulfate. Bromine, if present, is determined separately, and a correction is applied to the chlorine result.

39.2 It is recommended that the potassium iodide-sodium acetate solution be made up fresh once each week. Any color change signals the need for a new solution. As the solution ages, the blank result increases; therefore, the same potassium iodide solution is used for both sample and blank.

39.3 If the sample solution is allowed to boil too vigorously when chlorine gas is being released, liquid droplets may be carried by the nitrogen stream into the potassium iodide solution, resulting in sample bias.

40. Apparatus

40.1 *Distillation Apparatus*, shown in Fig. 6.

41. Reagents

41.1 *Boric Acid* (H_3BO_3), reagent grade, crystal or powder.

41.2 *Ferrous Sulfate Solution*—5 g $FeSO_4 \cdot 7H_2O$ dissolved in 500 mL of 3.6 M sulfuric acid.

41.3 *Potassium Iodide* (KI), reagent grade.

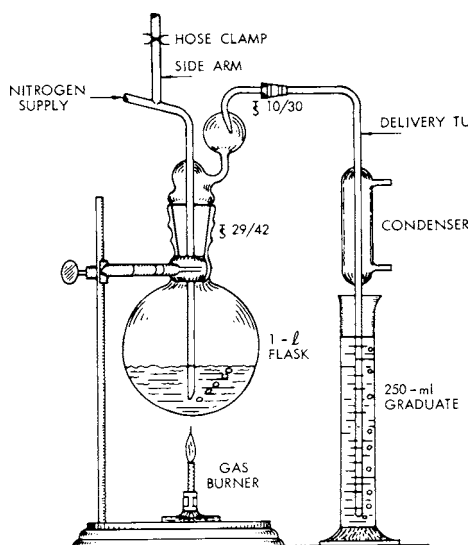

FIG. 6 Apparatus for Distillation of Chlorine

41.4 *Potassium Iodide-Sodium Acetate Solution*—Dissolve 100 g of KI and 100 g of $\text{NaC}_2\text{H}_3\text{O}_2 \cdot 3\text{H}_2\text{O}$ in distilled water and dilute to 2 L.

41.5 *Potassium Permanganate Solution (1 %)*—Prepare a 1 % solution of KMnO_4 in water.

41.6 *Sodium Acetate* ($\text{NaC}_2\text{H}_3\text{O}_2$), reagent grade.

41.7 *Sodium Thiosulfate Solution (0.025 N)*—Prepare a 0.025 N solution of $\text{Na}_2\text{S}_2\text{O}_3$ in water.

41.8 *Starch Indicator Solution*, pH 7.

41.9 *Sulfuric Acid (sp gr 1.84)*—Concentrated sulfuric acid (H_2SO_4).

42. Procedure

42.1 Sample Preparation:

42.1.1 Hydrolyze the sample of UF_6 with distilled water. Approximately 250 g of UF_6 from a nickel knockout container (Note) may be hydrolyzed to provide a sample for various chemical measurements, or about 20 g from two polychlorotrifluoroethylene sample tubes may be hydrolyzed to provide the chlorine sample. The procedure for hydrolyzing the contents of the polychlorotrifluoroethylene tubes is described here.

42.1.1.1 Immerse the tubes in liquid nitrogen and cool for 10 min.

42.1.1.2 Remove the top flare plugs and collars, and place the tubes into a platinum dish or a polychlorotrifluoroethylene beaker containing 100 mL of chilled distilled water.

42.1.1.3 After hydrolysis of the UF_6 , remove the polychlorotrifluoroethylene tubes and rinse with distilled water. Add the rinse solution to the UO_2F_2 solution.

42.2 Analysis:

42.2.1 Fill the graduated cylinder in Fig. 5 to the 150-mL level with KI- $\text{NaC}_2\text{H}_3\text{O}_2$ solution. Then connect the delivery tube so its tip is near the bottom of the solution in the receiving graduate.

42.2.2 Dispense 20 g of H_3BO_3 into the 1-L round-bottom flask.

42.2.3 Transfer the sample solution containing UO_2F_2 from approximately 20 g of UF_6 in 100 mL of solution to the flask.

42.2.4 Add 10 mL of concentrated H_2SO_4 (sp gr 1.84) to the flask, and swirl the contents for mixing.

42.2.5 Add 10 mL of the FeSO_4 solution, rinse the mouth of the flask, and connect the flask immediately to the apparatus as in Fig. 6.

42.2.6 Initiate nitrogen flow through the solution at a rate of 2 to 3 bubbles per second, and start the water flow through the condenser.

42.2.7 Heat the contents of the flask until boiling and allow to boil for 30 s.

42.2.8 Remove the heat, add 10 mL of 1 % KMnO_4 solution through the sidearm, and close the sidearm by clamping the rubber tube that is attached to the end of the sidearm.

42.2.9 Reapply heat, and allow the contents of the flask to simmer for 5 min.

42.2.10 Remove the heat, but continue the nitrogen purge for an additional 5 min.

42.2.11 Rinse the delivery tube into the receiving graduate, and transfer the contents of the graduate to a 300-mL Erlenmeyer flask. Add 1 mL of starch solution, and titrate the iodine with 0.025 N $\text{Na}_2\text{S}_2\text{O}_3$ solution to the starch end point. (The iodine may be measured spectrophotometrically rather than titrimetrically.)

42.2.12 Perform a blank analysis by carrying 100 mL of distilled water through procedural steps, 42.2.1 through 42.2.11, and subtracting from the sample titration.

43. Calculation

43.1 Calculate the concentration of chlorine in parts per million chlorine on a uranium basis as follows: $\text{Cl, ppm} = (V_1 - V_2) (N) (0.03545 \times 10^4) / S$.

where:

- V_1 = millilitres of thiosulfate for sample,
- V_2 = millilitres of thiosulfate for blank,
- N = normality of $\text{Na}_2\text{S}_2\text{O}_3$ solution, and
- 0.03545 = grams of chlorine per milliequivalents, and
- S = grams of uranium.

44. Reliability

44.1 The precision at the 95 % confidence level is ± 10 % at the 100-ppm level.

DETERMINATION OF SILICON AND PHOSPHORUS

45. Scope

45.1 Phosphorus and Silicon can be determined by ICP-MS (see Test Method C 1287).

45.2 Silicon can be analyzed by Atomic Absorption without matrix separation.

45.3 Phosphorus and Silicon can be analyzed in gaseous UF_6 by Fourier Transform Infra Red Spectrometry (FTIR), see Test Method C 1441.

45.4 Silicon can be determined by Spectrographic Emission (see section 52).

45.5 Phosphorus and Silicon can be analyzed by spectrophotometry (as described below). With these procedures about 0.5 μg silicon or phosphorus per gram of uranium can be detected.

46. Summary of Test Method

46.1 The test methods are based on the development of the color known as molybdenum blue obtained by the reduction of silico- or phosphomolybdate ions.

46.2 Reduction of the silico- or phosphomolybdate ions with a combination 1-amino-2-naphthol-4-sulfonic acid, sodium sulfite, sodium pyrosulfite solution produces the same molybdenum blue complex that is measured spectrophotometrically, directly in the uranium solution at 710 nm. One gram of uranium absorbs slightly at this wavelength, but its absorbance is easily corrected by the use of an additional aliquot to which no reducing agent is added as the blank.

47. Interferences

47.1 Phosphate interference in the silicon determination is eliminated by the addition of oxalic acid to decompose any phospho-molybdate formed. Silicon in small amounts does not interfere in the phosphorus analysis since silicomolybdate does not form at the acid concentration at which the phosphomolybdic acid is formed.

47.2 Fluoride, which would be a serious interference in the silicon analysis, is complexed with boric acid. A high concentration of silicon which could interfere in the phosphorus analysis is prevented by handling hydrolyzed UF₆ samples in platinum or plastic. Other potential interferences rarely present in significant amounts are arsenic and tungsten.

48. Apparatus

48.1 *Polyethylene Bottles*, 100 and 500-mL.

48.2 *Polyethylene Beakers*, 100-mL.

48.3 *Polyethylene Pipets*; 1, 2, 5, and 10-mL.

48.4 *Spectrophotometer*, equipped with 1 and 5-cm cells as described in Practice E 60.

49. Reagents

49.1 *Ammonium Hydroxide Silicon-Free*—Distill 500 mL of saturated NH₄OH through plastic tubing into 300 mL of distilled water.

49.2 *Ammonium Molybdate Solution (10 %)*—Dissolve 100 g of reagent grade (NH₄)₆Mo₇O₂₄ in water, and dilute the solution to 1 L with distilled water.

NOTE 5—Not all commercially available (NH₄)₆Mo₇O₂₄ is suitable. Material supplied by J. T. Baker Chemical Co. or Baker and Adamson Products, however, has been found to be satisfactory consistently.

49.3 *Boric Acid Solution (5 %)*—Dissolve 25 g of reagent grade H₃BO₃ in water, and dilute the solution to 500 mL.

49.4 *Oxalic Acid Solution (5 %)*—Dissolve 25 g of reagent grade H₂C₂O₄ in water, and dilute the solution to 500 mL. (This solution is not required for determination of phosphorus.)

49.5 *Phosphorus Standard Solution (25 µg P/mL)*—Dissolve 4.6422 g of ammonium dihydrogen phosphate [(NH₄)H₂PO₄] in distilled water and dilute the solution to 1 L with distilled water. Transfer 20 mL of this solution to a 1-L volumetric flask and dilute to 1 volume with distilled water to obtain a solution containing 2.0 µg P/mL.

49.6 *Reducing Mix*—Dissolve 0.1 g of 1-amino-2-naphthol-4-sulfonic acid, 1.0 g of sodium sulfite (Na₂SO₃), and 10.0 g of sodium pyrosulfite (Na₂S₂O₅) in water; then dilute the solution to 100 mL.

49.7 *Silicon Standard Solution (2.5 µg Si/mL)*—Dissolve 10.6 mg of precipitated silica (SiO₂) and 0.5 g of sodium hydroxide (NaOH) in a platinum dish. Transfer the solution to a 2-L plastic bottle, and dilute to volume.

NOTE 6—Silicon in solution as sodium silicate is not stable when stored in polyethylene bottles. New standard solutions should be prepared monthly.

49.8 *Sulfuric Acid—Boric Acid Solution (10 % H₂SO₄—4 % H₃BO₃)*—Dissolve 20 g of reagent grade H₃BO₃ in water. Add 50 mL of concentrated H₂SO₄ (sp gr 1.84), and dilute the solution to 500 mL.

49.9 *Uranium Oxide (U₃O₈, UO₂, or UO₃)*, phosphorus- and silicon-free.

NOTE 7—All standard solutions should be made and stored in plastic containers to prevent silicon contamination from glassware.

50. Procedure

50.1 Sample Preparation:

50.1.1 Hydrolyze a weighed portion of 6 to 10 g of UF₆ in a platinum boat in 80 mL of distilled water as described in 17.7 through 17.17.

50.1.2 Transfer the solution to a 100-mL plastic bottle and dilute to 100 mL.

50.1.3 Transfer an aliquot equivalent to 1 g of UF₆ to a 100-mL TFE-fluorocarbon beaker, and add 1 mL of 6 N H₂SO₄. (Phosphorus aliquots should contain 1 to 50 µg of phosphorus.)

50.1.4 Add 20 mL of 5 % H₃BO₃, and heat the solution for 20 min to complex the fluoride.

50.1.5 For phosphorus analysis only, transfer the solution to a 100-mL borosilicate beaker and evaporate to 20 mL (see 50.3).

50.2 Determination of Silicon:

50.2.1 Preparation of Calibration Curve:

50.2.1.1 Pipet standard aliquots containing 0, 2.5, 5.0, 7.5, 10.0, and 12.5 µg of silicon into plastic beakers.

50.2.1.2 Add silicon-free uranium, 0.1 g as uranyl nitrate solution, to each beaker. Prepare the uranyl nitrate solution by dissolving silicon-free uranium oxide in nitric acid in a TFE-fluorocarbon beaker.

50.2.1.3 Add from 1.0 to 1.5 mL of 18 N H₂SO₄ to each beaker and dilute to 25 mL. Then proceed with the analysis starting with 50.2.2.4. Plot the absorbances corrected for the blank against the known quantities of silicon taken to obtain a calibration curve. In a typical case, 10 µg of silicon gave a corrected absorbance of about 0.285 in a 5-cm cell. Up to about 150 µg can be handled using a 1-cm absorbance cell and an appropriate calibration curve.

50.2.2 Analysis:

50.2.2.1 A blank containing all the reagents in the amounts used in the sample aliquot must be analyzed with the samples. Normally 10 mL of 1 N NaOH solution gives an absorbance of 0.030 to 0.050 in this procedure. Most other reagents were found to be nearly silicon-free.

50.2.2.2 Dilute the aliquot of the sample in a 100-mL plastic beaker to 25 mL with water.

50.2.2.3 Add from 1 to 1.5 mL of 18 *N* H₂SO₄.

50.2.2.4 Place the TFE-fluorocarbon beaker containing the sample in a water bath or an oven and heat to 90 to 95°C.

50.2.2.5 Remove the beaker from the water bath or the oven, and add 5 mL of 10 % (NH₄)₆Mo₇O₂₄ solution immediately.

50.2.2.6 Adjust the acidity to a pH of 1.2 to while the solution is still warm by adding silicon-free NH₄OH or HCl.

50.2.2.7 Allow the sample to stand 10 min to permit the formation of the silico-molybdate complex.

50.2.2.8 Add 10 ml of 5 % H₂C₂O₄ solution to the beaker and swirl. Allow the solution to stand for 2 min to decompose any phosphomolybdate.

50.2.2.9 Add 2 mL of reducing mix to the beaker and swirl.

50.2.2.10 Add sufficient 6 *N* HCl immediately to the sample to obtain a 1 *N* acid solution.

50.2.2.11 After all the precipitate is dissolved, transfer the solution to a 50 or 100-mL volumetric flask and dilute to volume with 1 *N* HCl.

50.2.2.12 Determine the absorbance of the solutions in a 5-cm cell at 710 nm.

NOTE 8—The uranyl ion shows a slight absorbance at 710 nm, and samples must be corrected for this absorbance. This is best determined by taking an additional aliquot from the sample solution and treating it as indicated in the procedure up to the point the pH is adjusted with NH₄OH. Any precipitate is dissolved with a minimum of H₂SO₄ and the solution diluted to 50 mL. The absorbance of this solution is used as an additional blank correction.

50.2.2.13 Determine the quantity of silicon in the aliquot from a previously prepared calibration curve.

50.3 Determination of Phosphorus:

50.3.1 *Preparation of Calibration Curve*—Using a TFE-fluorocarbon beaker, dissolve sufficient uranium oxide (phosphorus-free) containing 20 g of uranium in HNO₃. Dilute it to 200 mL in a plastic bottle. To separate 10-mL aliquots, add 0, 5, 10, 25, and 50 µg of phosphorus. Analyze by the procedure described below. Plot the absorbances corrected for the blanks against the known quantities of phosphorus to obtain a calibration curve.

50.3.2 Analysis:

50.3.2.1 Neutralize the sample aliquot containing 1 to 50 µg of phosphorus in a volume of 20 mL or less in a 100-mL borosilicate beaker with NH₄OH until a precipitate begins to form.

50.3.2.2 Add sufficient 6 *N* HCl to make the sample 1 *N* in acid.

50.3.2.3 Transfer the sample to a 100-mL volumetric flask and dilute to about 50 mL with 1 *N* HCl.

50.3.2.4 Add 5 mL of (NH₄)₆Mo₇O₂₄ solution.

50.3.2.5 Heat the sample to 90 to 95°C in a water bath.

50.3.2.6 Allow the sample to cool to room temperature in a water bath; add 2 mL of reducing mix to the solution and swirl.

50.3.2.7 Dilute the solution in the 100-mL volumetric flask to volume with 1 *N* HCl.

50.3.2.8 After 1 h, measure the absorbance of the solution in a 5-cm cell at 710 nm against a reagent blank.

NOTE 9—Since the uranyl ion absorbs slightly at this wavelength, a correction must be made for the quantity of uranium present. This can be done by measuring the absorbance of an additional untreated aliquot of the original sample made to a 50-mL volume or by applying a previously determined standard correction when the amounts of uranium in the aliquot are known (typically, each gram of uranium in a 50-mL volume gives an absorbance reading of 0.038 at 710 nm).

50.3.2.9 Determine the quantity of phosphorus present in the aliquot from a previously prepared calibration curve. Then calculate the phosphorus content of the original material on the basis desired.

51. Reliability

51.1 At the 10-µg level of either element, the precision at the 95 % confidence level is ±10 %.

DETERMINATION OF BORON AND SILICON

52. Scope

52.1 Boron and Silicon can be determined by ICP-MS (see Test Method C 1287). They can also be analyzed by FTIR on gaseous UF₆ (see Test Method C 1441). The following test method uses DC-arc spectrographic emission. It applies for the determination of boron and silicon in UF₆ in the concentration ranges from 0.5 to 100 µg/g for boron and 2 to 100 µg/g for silicon.

53. Summary of Test Method

53.1 A sample of UF₆ is transferred as a liquid into a polychlorotrifluoroethylene tube, frozen with liquid nitrogen, and hydrolyzed in freshly prepared ammonia water in a closed polyethylene bottle. The solution is evaporated to dryness in a platinum dish, and the residue is analyzed spectrographically for boron and silicon.

54. Limitations

54.1 Precautions must be taken to prevent loss of the highly volatile fluorides of boron and silicon, especially from warm acid fluoride solutions. In the hydrolysis step, boron and silicon are converted to the fluoborate and fluosilicate ions, respectively. Temperatures in excess of 100°C must be avoided during the drying step to avoid loss of boron and silicon.

54.2 The greatest problem encountered is obtaining suitable material for standards, especially in the case of silicon. A satisfactory approach to obtaining acceptable base material involves making an analytical survey of various lots of UF₆ and selecting a lot which is low in boron and silicon. The amount of boron and silicon in the base material is determined by taking some of the material, making standard additions of boron and silicon, preparing spectrographic plates, and plotting the element intensities of the base material and the base material plus standards. The use of such a standard addition method makes possible suitable extrapolations of the boron and silicon in the original base material. The same study will provide an estimate of the lower limits of detection for these elements.

55. Apparatus

55.1 *Polyethylene Bottle with Cap*, 500-mL.

55.2 *Mixer-Mill Grinder*.

55.3 *Plastic Vials*, 20 mm in diameter by 51 mm long.

55.4 *Ball Pestles*, acrylic plastic 10 mm in diameter.

55.5 *Spectrograph*—A grating spectrograph with a reciprocal linear dispersion of 5 Å/mm in the first order and providing wavelength coverage from 2250 to 2900 Å.

55.6 *Excitation Source*, providing a 4-A d-c arc.

55.7 *Comparator-Microphotometer*—A comparator providing sufficient magnification and facility to compare spectral line density with a reference standard plate or film, and a microphotometer having a precision of ±1.0 % for transmittance values between 5 and 90 %.

55.8 *Vent-Forming Tool*, shown in Fig. 7.

55.9 *Electrodes, Graphite*:

55.9.1 *Lower*—6.15-mm rod with a cup 4.75 mm in diameter and 7.14 mm deep, high-density grade (Practice E 130, Type S-3).

55.9.2 *Boiler Cap*—7.75 mm outside diameter, 6.15 mm inside diameter with a 0.96-mm diameter vent hole. (National Carbon SPK L-3715 or equivalent.)

55.9.3 *Upper*—3.05-mm rod, 38.10 mm long, pointed (Practice E 130, Type C-1).

55.10 *Photographic Plate*, Eastman Kodak Spectrum Analysis No. 1.

55.11 *Photographic Processing Equipment*, providing developing, fixing, washing, and drying operations and conforming to the requirements of Practices E 115.

56. Reagents

56.1 *Boron-Silicon, Standard Solution*—Prepare a standard solution containing boron and silicon, each at 1000 µg/g (on a uranium basis), by adding known amounts of ammonium

fluoroborate (NH₄BF₄) and ammonium fluosilicate [(NH₄)₂SiF₆] to a known amount of boron- and silicon-free hydrolyzed UF₆(hydrolyzed in saturated ammonia water). Evaporate the hydrolyzed uranium solution to dryness on a steam bath, and blend the residue. Prepare the lower standards by making appropriate dilutions with base material that is prepared in a similar manner and blanked. Prepare a standard spectral plate using the following concentrations (µg/g): 100, 50, 20, 10, 5, 2, 1, 0.5, blank.

57. Procedure

57.1 Sample Preparation Procedure:

57.1.1 By means of a suitable sampling system, transfer approximately 5 g of liquid UF₆ to a tared polychlorotrifluoroethylene tube. Cool the tube in liquid nitrogen, disconnect from the sampling system, and seal with a threaded plug.

57.1.2 Weigh the filled tube to obtain the sample weight.

57.1.3 Prepare a fresh ammonia water solution by bubbling ammonia gas through approximately 300 mL of distilled water in a clean 500-mL polyethylene bottle until the water is saturated.

57.1.4 Cool the polychlorotrifluoroethylene tube in liquid nitrogen, remove the metal fittings, and drop the tube into the ammonia water.

57.1.5 Immediately cap the bottle, and hydrolyze the contents in the polychlorotrifluoroethylene tube while shaking the bottle.

57.1.6 Transfer the slurry to a platinum dish.

57.1.7 Rinse the bottle with distilled water, and transfer the rinse solution to the platinum dish.

57.1.8 Evaporate the contents of the dish to dryness on a steam bath. Loss of boron or silicon may result if the temperature exceeds 100°C.

57.1.9 Transfer the residue to a plastic vial, add a ball pestle, and grind the mixture on the mixer-mill.

57.1.10 Weigh three 50-mg charges of the ground sample, and transfer each to an electrode.

57.1.11 Pack the sample into the bottom of the cavity by holding the electrode with a pair of forceps and tapping it briskly on the bench top.

57.1.12 Make a vent hole in the charge with the vent-forming tool shown in Fig. 7.

57.1.13 Place a boiler cap on top of the electrode.

57.2 Spectrograph Operation Procedure:

57.2.1 Position the plate holder containing one photographic plate on the spectrograph, and adjust the spectrograph as follows:

Slit height	3 mm
Slit width	25 µm
Timer	on and set for 45 s
Preburn timer	off
Spectral region, nm	225.0 to 290.0
Excitation	4 A dc

57.2.2 Wipe off the electrode clamps, insert the electrodes, and adjust the gap distance to 4 mm by adjusting the projected image of the gap on the target screen.

57.2.3 Turn on the d-c arc, and adjust the source to 4 A.

57.2.4 Adjust the upper electrode to maintain a 4-mm gap distance throughout the exposure.

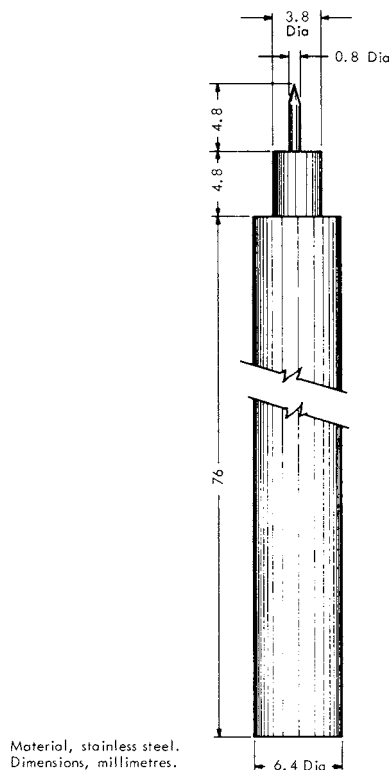

FIG. 7 Vent-Forming Tool

57.2.5 At the completion of the exposure, remove the electrode, dump the charge into the scrap container, and discard both electrodes.

57.2.6 Rack the plate holder, and repeat the exposure cycle with the second and third electrodes of the sample.

57.2.7 After the sample exposures, rack the plate holder, and expose a sample of iron for 5 s at 4 A.

57.2.8 *Photographic Processing*—Process the plates in accordance with Practices E 115.

58. Photometry and Calculation

58.1 Using the comparator-microphotometer, compare the density of the elemental lines in the unknown spectrum visually with those on a standard plate to estimate the concentrations of boron and silicon. Average the results of replicate exposures. Use the following lines for the identification and estimation of boron and silicon:

Element	Wavelength, nm
Boron	249.68
Boron	249.77
Silicon	250.69
Silicon	251.61
Silicon	288.16

58.2 For a more precise value when an element concentration is measurable, measure the transmittance of the analytical line using the microphotometer. Convert this value to direct intensity, using the emulsion calibration chart, and calculate the concentration of the element from a previously prepared calibration curve which relates intensity to concentration.

59. Reliability

59.1 The precision of a single determination at the 95 % confidence level is $\pm 2 \mu\text{g/g}$ for boron and $\pm 3 \mu\text{g/g}$ for silicon, determined at both the 5- $\mu\text{g/g}$ and 20- $\mu\text{g/g}$ levels.

DETERMINATION OF RUTHENIUM

60. Scope

60.1 Ruthenium can be determined by ICP-MS (see Test Method C 1287). The Atomic Absorption test method using MIBK extraction has been discontinued (see C 761–96). The Spectrographic determination of Ruthenium has been discontinued (see C 761–96).

DETERMINATION OF TITANIUM AND VANADIUM

61. Scope

61.1 Titanium and Vanadium can be determined by ICP-MS (see Test Method C 1287). They can also be determined by ICP-AES as described later in this document. The Spectrophotometric determination of these elements with BHPA-Chloroform extraction has been discontinued (see C 761–96).

SPECTROGRAPHIC DETERMINATION OF METALLIC IMPURITIES

62. Scope

62.1 The Spectrographic determination of metallic impurities with BHPA or Cupferrides extraction has been discontinued (see C 761–96). Most elements can be analyzed by

ICP-MS (see Test Method C 1287), or Atomic Absorption and ICP-AES (see further sections).

62.2 Arsenic can be analyzed with Test Method C 1219 or Test Method C 1287.

DETERMINATION OF TUNGSTEN

63. Scope

63.1 Tungsten can be determined by ICP-MS (see Test Method C 1287) or by ICP-AES as described later in this document. The Spectrophotometric determination has been discontinued (see C 761–96).

DETERMINATION OF THORIUM AND RARE EARTHS

64. Scope

64.1 Thorium and rare earths can be determined by ICP-MS (see Test Method C 1287). Thorium can also be determined by spectrophotometry. This test method is described below. Using a sample aliquot containing 0.5 g of uranium, the test method can detect 2 $\mu\text{g Th/g U}$. This range can easily be extended to a much lower level by use of a larger sample size.

65. Summary of Test Method

65.1 Thorium is separated from uranium by a rapid ion exchange procedure in which the uranium is adsorbed on a strongly basic anion exchange resin from 8 M HCl (48). The thorium-bearing effluent is treated directly with oxalic acid to complex any zirconium and with Arsenazo III to develop the blue thorium-Arsenazo III complex which has a molar absorptivity of 116 000 in about 5 M HCl solution (49, 50). The test method is nearly specific for thorium since the potential interferences of uranium, and up to about 200 μg zirconium, are eliminated by the standard procedure. Rare earths at levels about 50 times the thorium also interfere.

65.2 This test method can be adapted to handling a large volume of samples by reducing the sample aliquot to a quantity small enough to contain 0.1 g of uranium. Ten samples can be passed through the ion exchange column before it is necessary to elute the uranium. Under these conditions the limit of detection becomes 10 $\mu\text{g Th/g U}$, which is adequate for most purposes.

66. Apparatus

66.1 *Ion Exchange Columns*, Fig. 8.

66.2 *Spectrophotometer*, with 1-cm cells as described in Practice E 60.

66.3 *Platinum Dishes*, 100-mL.

67. Reagents

67.1 *Arsenazo III* [*o*-(1,8-dihydroxy-3,6-disulfo- naphthyl-ene - 2,7 - bisazo)-bisbenzenearsonic acid, disodium salt] Solution (0.2 %)—Dissolve 0.2 g of Arsenazo III in water, add 1 mL of 5 % sodium carbonate (Na_2CO_3) to the solution, and adjust the volume to 100 mL with distilled water.¹¹

¹¹ Arsenazo III is available from the J. T. Baker Chemical Co. as Item No. B577.

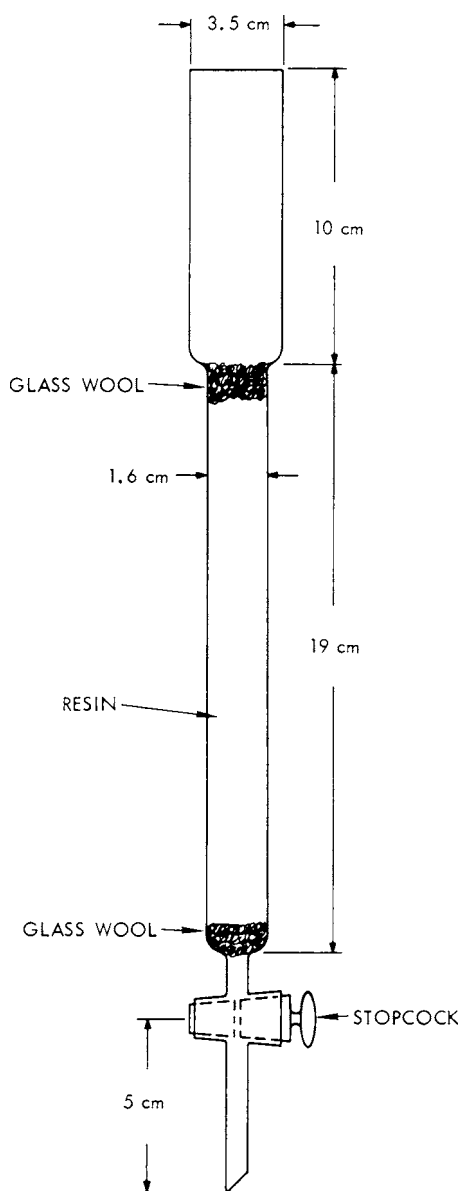

FIG. 8 Adsorption Column

67.2 *Dowex 1-X8* (50 to 100 mesh), a strongly basic anion exchange resin. Treat new resin with at least 100 mL of 8 M HCl before use, and discard the resin after it has been used three times.

67.3 *Oxalic Acid Solution (5 %)*—Dissolve 5 g of $H_2C_2O_4$ in distilled water and dilute to 100 mL.

67.4 *Thorium Standard*—Weigh 0.2393 g of thorium nitrate [$Th(NO_3)_4 \cdot 4H_2O$] into a 250-mL beaker and fume to dryness three times with 5-mL portions of concentrated HCl (sp gr 1.19). Dissolve the residue in 0.1 M HCl and dilute to 1 L with 0.1 M HCl to give a solution containing 100 μg Th/mL. Dilute an aliquot to the appropriate volume to give a solution containing 5 μg Th/mL.

68. Procedure

68.1 Measure a sample aliquot of hydrolyzed UF_6 containing no more than 0.5 g of uranium and up to 50 μg of thorium by weight or volume into a 100-mL platinum dish.

68.2 Fume the solution to dryness four times with 10-mL portions of concentrated HCl (sp gr 1.19) to remove fluoride.

68.3 Dissolve the residue in 2 to 3 mL of concentrated HCl (sp gr 1.19) using heat if necessary.

68.4 Dilute the solution to about 10 mL with 8 M HCl and transfer to the ion exchange column.

68.5 Rinse the beaker with a minimum quantity of 8 M HCl (about 5 mL), and add the rinse solution to the column.

68.6 Open the stopcock, and drain the column into a suitable graduated cylinder at a rate of 3 to 4 mL/min.

68.7 Discard the first 7 mL of effluent, and collect the remaining effluent in a 50-mL, volumetric flask.

68.8 Wash the resin with two 5-mL and two 10-mL portions of 8 M HCl; collect all the effluents in the 50-mL flask.

68.9 Add 1 mL of 5 % $H_2C_2O_4$ to the flask to complex any zirconium.

68.10 Add 2 mL of Arsenazo III solution to the flask, and dilute the solution to volume with distilled water and mix thoroughly.

68.11 Within 30 min, measure the absorbance of the solution in a 1-cm cell at 665 nm against a blank solution containing all reagents.

68.12 Determine the concentration of thorium from a calibration curve prepared previously as in the above procedure. This calibration curve is prepared from solutions having a concentration range from 0 to 100 μg Th/50 mL.

NOTE 10—It is necessary to run the calibration standards through the ion-exchange column.

68.13 Elute the uranium from the exchange column with 200 mL of 0.1 M HCl at the rate of 3.0 to 3.5 mL/min. Then, pass 50 mL of 8 M HCl through the column to prepare it for the next sample.

NOTE 11—The test method can be adapted to handling a large volume of samples by taking sample aliquots containing 0.1 g of uranium and eluting the uranium from the column after ten sample aliquots have been passed through the column. When the column is used in this manner, it should be washed with an extra 50 mL of 8 M HCl between successive samples.

69. Reliability

69.1 The precision at the 95 % confidence level in determining 200 μg Th/g U by the standard procedure is ± 5 %.

DETERMINATION OF MOLYBDENUM

70. Scope

70.1 Molybdenum can be determined by ICP-MS (see Test Method C 1287) or by ICP-AES as described later in this document. The Spectrophotometric determination using the thiocyanate complex has been discontinued (see C 761-96).

ATOMIC ABSORPTION DETERMINATION OF METALLIC IMPURITIES

71. Scope

71.1 A test method is presented for the analysis of 14 metallic elements in uranium compounds by atomic absorption spectroscopy (56, 57). The test method has been shown to be

applicable to the analysis of aluminum, cadmium, calcium, chromium, cobalt, copper, iron, lead, magnesium, manganese, nickel, potassium, sodium, and zinc.

72. Summary of Test Method

72.1 The uranium in a sample is separated by solvent extraction with tributylphosphate (TBP) from 6 to 8 *N* HNO₃ (58). The HNO₃ solution containing the elements to be determined is evaporated to dryness and the residue redissolved in 0.2 *N* HCl. Any or all of the elements can then be determined in this one solution by standard atomic-absorption spectrometry procedures with little or no matrix effects in the usual type of sample.

72.2 Direct atomic-absorption analysis of several elements in uranium solutions is sometimes satisfactory (59, 60).

72.3 The uranium is extracted with pure TBP from 6 *N* HNO₃. The aqueous layer is then washed with 20 % TBP in chloroform. A total of 99.9 % of the uranium is removed, leaving a nearly residue-free solution when the HNO₃ solution is evaporated to dryness. Since all atomic absorption analyses are then made in exactly the same medium, that is, 0.2 *N* HCl solution, standards preparation is simplified, and conditions for maximum precision and accuracy are ideal.

72.4 In relatively pure UF₆ that is usually analyzed by this test method, there is usually no problem with anionic interference. Fluoride can interfere with the extraction, but it is easily removed before the extraction by pyrohydrolysis or by fuming the sample with HNO₃. Sulfate and phosphate are possible interferences in the extraction, but they are rarely present in significant quantities.

72.5 Where more than one element is to be analyzed, the atomic absorption procedure requires substantially less labor per analysis than spectrophotometric methods. Furthermore, for some elements such as magnesium, potassium, and sodium, no satisfactory spectrophotometric methods are available. Compared to the carrier distillation spectrographic method, the atomic absorption procedure, though longer, provides better sensitivity and range, and much better precision and accuracy.

73. Apparatus

73.1 *Atomic Absorption Spectrophotometer*, as described in Proposed Recommended Practices for Atomic Absorption Spectrometry.

74. Reagents

74.1 *Carbon Tetrachloride, Reagent Grade*—Wash 1 L of CCl₄ with 100 mL of 0.1 *N* HNO₃ and then with 100 mL of deionized water.

NOTE 12—**Caution:** Carbon tetrachloride must be handled with due safety precautions. It should be handled in a hood to avoid breathing its vapor.

74.2 *Hexane, Reagent Grade*—Wash 1 L of C₆H₁₄ with 100 mL of 0.1 *N* HNO₃ and then with 100 mL of deionized water.

74.3 *Hydrochloric Acid, Purified*—Distill and determine the normality as for HNO₃.¹²

74.4 *Hydrochloric Acid (0.2 N)*—Prepare by appropriate dilution of purified HCl with deionized water.

74.5 *Lanthanum Chloride (LaCl₃), Purified (50 mg/mL)*—Transfer 200 mL of saturated lanthanum nitrate [La(NO₃)₃], 400 mL of 2.0 *N* aluminum nitrate [Al(NO₃)₃], and 300 mL of purified TBP to a 1-L separatory funnel. Shake the solution vigorously for 2 min to extract lanthanum. Discard the aqueous layer, and wash the TBP phase twice with 100 mL of deionized water. Discard these washings. Transfer the TBP phase to a 1-L beaker. Add about 500 mL of calcium-free acetone or ethanol and 50 mL of water. Distill NH₄OH into this solution until precipitation of lanthanum hydroxide [La(OH)₃] is complete. Filter the precipitate and wash with deionized water. Ignite the precipitate at 800°C to form lanthanum oxide (La₂O₃). Dissolve the La₂O₃ (58.64 g) in purified HCl, and dilute to 1 L with deionized water.

74.6 *Nitric Acid (HNO₃), Purified*—Distill approximately 1700 mL of concentrated HNO₃ (sp gr 1.42) into a 2-L plastic bottle containing 400 mL of deionized water. A quartz still is preferable for the distillation, but if one is not available, borosilicate glassware is satisfactory. Determine the specific gravity of the distilled HNO₃, and calculate the normality.¹²

74.7 *Nitric Acid (6.0 N)*—Prepare by appropriate dilution of purified HNO₃ with deionized water.

74.8 *Standard Stock Solution, 100 µg/mL of Each Element*—Prepare a stock solution containing all elements to be determined by dissolving 0.100 g ± 0.1 mg each of the pure metals in purified HNO₃ or HCl. Convert the nitrate solutions to chloride when feasible by digestion with HCl. Add lead as the nitrate. Dilute the stock solution to 1 L with 0.2 *N* HCl. After a preliminary analysis has been made on an unknown sample to determine the approximate concentration of impurities, dilute aliquots of the stock solution to give concentrations that bracket the sample.

74.9 *n-Tributylphosphate (TBP), Purified*—Wash 500 mL of purified TBP with at least four 500-mL portions of deionized water to remove sodium and orthophosphate.

NOTE 13—For determining low concentrations of sodium (for example, <5 µg/g U), special purification steps such as vacuum distillation in a quartz system may be required.

74.10 *Urano-Uranic Oxide (U₃O₈)*—Hydrolyze redistilled UF₆ in deionized water to form uranyl fluoride (UO₂F₂). Evaporate the solution to dryness in a platinum dish and pyrohydrolyze the residue at 900°C for 6 to 8 h with occasional mixing to form U₃O₈.

75. Procedure

75.1 Hydrolyze enough UF₆ to contain the desired amount of uranium (5 to 20 g) with deionized water.

75.2 Evaporate the solution to dryness under heat lamps, and convert the UO₂F₂ to U₃O₈ by pyrohydrolysis at 900°C for 45 min. (U₃O₈ produced in the gravimetric analysis of uranium in UF₆ is suitable.)

NOTE 14—If elements that form volatile fluorides are to be analyzed by atomic absorption, the UO₂F₂ solution should be digested with HNO₃ several times to remove fluoride and obtain a suitable UO₂(NO₃)₂ solution for the extraction.

¹² Alternatively, high purity/distilled acids may be purchased from a vendor.

75.3 Weigh enough U_3O_8 to give the desired weight of uranium (to the nearest milligram) into a platinum dish or a TFE-fluorocarbon beaker.

75.4 Dissolve the sample in purified concentrated HNO_3 (sp gr 1.42, 1 mL acid per gram of oxide), and evaporate the solution to near dryness.

NOTE 15—When uranium fluorides containing chromium are pyrohydrolyzed, a nitric acid-insoluble compound, probably $CrUO_4$, is formed. Consequently, samples to be analyzed for chromium must be fumed with perchloric acid ($HClO_4$) after dissolution with HNO_3 to dissolve this uranium-chromium compound. Add a few drops of 30 % hydrogen peroxide (H_2O_2) to reduce chromium (VI) to chromium (III) before extraction of the uranium.

75.5 Dissolve the residue in 6 N HNO_3 , and dilute the solution to 100 mL with 6 N HNO_3 .

NOTE 16—Blanks containing all reagents *must* be run through the entire procedure.

75.6 Transfer the sample solution containing up to 10 g of uranium to a 250-mL separatory funnel, using 6 N HNO_3 to rinse the beakers. Use a 500-mL separatory funnel for samples containing 10 to 20 g of uranium. (Plastic separatory funnels are preferred.)

75.7 Add 50 mL of purified TBP to the separatory funnel for each 4 g of uranium.

75.8 Shake the separatory funnel vigorously for 2 min to extract the uranium.

75.9 Allow the phases to separate completely (this requires about 15 min).

NOTE 17—When the extracted sample contains 15 to 20 g uranium, the density of the TBP phase is greater than the density of the aqueous phase. Add 50 mL hexane after the extraction to reduce the density of the TBP phase. (If the hexane were added before the extraction, the resulting TBP-hexane mixture would have a lower extraction efficiency.)

75.10 Transfer the aqueous phase to a second separatory funnel. Wash the TBP phase with two 30-mL portions of 6 N HNO_3 , and add the washings to the second separatory funnel.

75.11 Wash the aqueous phase with 50 mL of 20 % TBP in CCl_4 . After separation, drain off the organic phase.

75.12 Wash the aqueous phase twice with 25-mL portions of CCl_4 .

75.13 Transfer the aqueous phase to a TFE-fluorocarbon beaker or platinum dish, and evaporate the solution to dryness.

75.14 Dissolve the residue in 0.2 N HCl and dilute to a desired volume according to the following tabulation:

Impurity, $\mu\text{g/g U}$	Wt of Uranium, g	Volume, mL
0.1–0.5	20	10
0.5–1	20	25
1–5	10	25
5–50	10	50–100
>50	5	100

75.15 Determine the desired elements by standard atomic absorption techniques, comparing the sample measurements to those of known standards in the same concentration ranges.

NOTE 18—Samples to be analyzed for calcium or magnesium require the addition of lanthanum or strontium to eliminate suppression. Pipet an aliquot of the sample into a volumetric flask, and add sufficient lanthanum or strontium chloride to give 10 mg of lanthanum or strontium per millilitre. Dilute the solution to volume with 0.2 N HCl and analyze by comparison to known standards also containing lanthanum or strontium.

75.16 Table 5 gives the operating parameters for the atomic-absorption analysis of the elements, using an atomic-absorption spectrometer equipped with a Bolog burner for all elements except aluminum, which must be analyzed with the nitrous oxide burner. Adjust the burner settings for a maximum absorption with copper and leave at those settings for the rest of the analyses.

76. Reliability

76.1 At the 1 to 10 $\mu\text{g/g U}$ level, all the elements except aluminum can be determined with a precision of $\pm 10\%$ at the 95 % confidence interval. The precision for the aluminum analysis is $\pm 30\%$ at the 95 % confidence interval.

IMPURITY DETERMINATION BY SPARK SOURCE MASS SPECTROGRAPHY

77. Scope

77.1 The spark-source mass-spectrographic technique has been discontinued (see C 761–96).

DETERMINATION OF BORON-EQUIVALENT NEUTRON CROSS SECTION

78. Scope

78.1 The determination of boron equivalent neutron cross section can be found in Practice C 1233.

DETERMINATION OF URANIUM-233 ABUNDANCE BY THERMAL IONIZATION MASS SPECTROMETRY

79. Scope

79.1 The determination of U 233 has been discontinued (see C 761–96). U 233 analysis could be performed referring to Test Method C 1413. However, the method should be adapted for the determination of this isotope.

DETERMINATION OF URANIUM-232 BY ALPHA SPECTROMETRY

80. Scope

80.1 This test method is applicable to the determination of uranium-232 in uranyl fluoride solutions, in concentrations as low as 0.05 ppb^{232U/U}.

TABLE 5 Operating Parameters for the Atomic-Absorption Analysis of the Elements

Element	Concentration Range, $\mu\text{g/mL}$	Wavelength, nm	Recommended Flows	
			Fuel	Air
Al	10–200	309.27	>15 ^A	8 (N_2O)
Ca	0–20	422.67	$\approx 9^A$	7.5
Cd	0.5–5	228.80	9	9
Co	4–20	240.73	9	9
Cr	2–20	357.87	$\approx 9^A$	7.5
Cu	2–20	324.75	9	9
Fe	2–20	248.33	9	9
K	1–10	766.48	9	9
Mg	0–2	285.21	≈ 9	7.5
Mn	2–20	279.48	9	9
Na	0.3–3	589.00	9	9
Ni	2–25	232.00	9	9
Pb	0–40	217.00	9	9
Zn	0–5	213.86	9	9

^AFuel adjusted to maximum percentage of absorption.

81. Summary of Test Method

81.1 Uranyl fluoride solutions are evaporated to dryness, and the uranium is converted to the oxide. A weighed portion of the oxide is dissolved in HNO_3 and electroplated on a stainless steel disk. The alpha activities from ^{232}U with energies of 5.28 and 5.32 MeV and ^{238}Th with energies of 5.34 and 5.42 MeV are measured with a pulse height analyzer. The two ^{232}U energy peaks are summed and corrected for the unresolved ^{238}Th 5.34 MeV. The counts are converted to disintegration rate and divided by the specific alpha activity of ^{232}U to determine the weight of ^{232}U on the disk.

82. Apparatus

82.1 *Multiple-cell Electroplating Apparatus (26)* with four cells operating independently of each other and the current within each cell automatically controlled to 3 A at 32 V dc. The speed of the stirrers shown in Fig. 9 is 500 rpm.

82.2 *Silicon Surface Barrier Detector*, or equivalent.

82.3 *Multichannel Alpha Spectrometer* with surface-barrier detector.

83. Reagents

83.1 *Ammonium Oxalate Solution, (0.4 M)*—Dissolve 56.8 of $(\text{NH}_4)_2\text{C}_2\text{O}_4 \cdot \text{H}_2\text{O}$ in warm distilled water and dilute to 1 L.

83.2 *Gas Mixture*—Ionizing gas for Frisch grid ionization chamber; 90 % argon, 10 % methane.

83.3 *Plutonium Standard*— ^{238}Pu and ^{239}Pu , with an activity approximately 10 000 cpm, deposited on a 52-mm diameter stainless steel disk.

83.4 *Neptunium Standard*— ^{237}Np on a 25-mm diameter stainless steel disk for an alpha activity of 50 000 to 100 000 disintegrations per minute. The activity on the disk should be calibrated such that it is traceable to national or international standards, e.g., in the U.S., standards maintained by the National Institute of Standards and Technology (NIST).

84. Procedure

84.1 Sample Preparation:

84.1.1 Evaporate the uranyl fluoride (UO_2F_2) solution, obtained by hydrolysis of a UF_6 subsample, to dryness; ignite to U_3O_8 in a platinum dish; and weigh the oxide.

84.1.2 Dissolve a sample containing 25 mg of uranium in 1 mL of 8 N HNO_3 and dilute to 500 mL.

84.1.3 Place a nickel disk (Grade A, cold-rolled, smooth finish, 52-mm diameter) in the center depression of the electroplating cell base plate, and a rubber gasket on a polychlorotrifluoroethylene or glass cell stack. (High-luster 300 series stainless steel can be substituted for nickel.)



FIG. 9 Multiple-Cell Electroplating Apparatus

84.1.4 Place the cell stack and gasket, as a unit, on a nickel or stainless steel disk which serves as the bottom and cathode of the electroplating cell.

84.1.5 Fasten the cell stack to the base plate, making a leak-proof seal between the disk and the cell stack.

84.1.6 Add 10 mL of 0.4 M (NH₄)₂C₂O₄ solution to the cell, then add a volume of sample containing 0.5 mg of uranium.

84.1.7 Adjust the volume of the solution to 25 mL with distilled water.

84.1.8 Place the cell in a water bath, between 75 and 85°C, on the electroplating apparatus.

84.1.9 Turn on the electroplating apparatus, and lower the platinum anode into the solution until the anode is about 10 mm above the disk.

84.1.10 Add distilled water to replace the water evaporated during electroplating.

84.1.11 After 45 min, remove the cell from the electroplating apparatus, and quickly pour out the electrolyte.

84.1.12 Rinse the cell with approximately 15 mL of ethyl alcohol to dry the film.

84.1.13 Disassemble the cell stack, and heat the uranium on the disk in a furnace at 425°C for 10 min.

84.2 Counting:

84.2.1 Place the ²³⁸Pu and ²³⁹Pu standard in the surface barrier detector chamber under the active area of the detector.

84.2.2 Connect the surface-barrier detector through the preamplifier and amplifier to the analyzer.

84.2.3 Turn on the vacuum pump connected to the detector chamber, and pump the chamber to a pressure of approximately 15 μm.

84.2.4 Adjust the detector bias voltage to the voltage specified for the detector.

84.2.5 Adjust the amplifier to cover a spectrum area approximately 3.7 to 7.0 MeV, and measure the alpha emissions 10 min to determine the resolution at 5.14 and 5.48 MeV. The resolution must not exceed 0.050 MeV.

84.2.6 Turn the bias voltage to zero.

84.2.7 Close the vacuum line, vent the detector chamber, and remove the plutonium standard.

84.2.8 Place the neptunium standard under the detector; adjust the vacuum and bias voltage as in 84.2.3 and 84.2.4, and alpha count 20 min to determine the counter efficiency factor. The activity of the standard has been determined on a parallel-plate alpha counter of known counter efficiency.

84.2.9 Remove the neptunium standard as in 84.2.7.

84.2.10 Place the uranium sample under the detector; adjust the vacuum and bias voltage as in 84.2.3 and 84.2.4, and count the sample 40 min. Lower the counting time if the sample contains a significant amount of ²³²U.

84.2.11 Obtain the sum of all counts in the 5.3 MeV peak (which includes the ²³²U at 5.32 and 5.28 MeV plus the unresolved ²²⁸Th at 5.34 MeV). Also, determine the sum of the ²²⁸Th counts in the 5.42–MeV peak.

85. Calculation

85.1 Convert total counts to net ²³²U counts per minute as follows:

$$^{232}\text{C} = (C_{5,3} - 0.394C_{5,42})/t \quad (12)$$

where:

²³²C = net ²³²U counts per minute,

C_{5,3} = total counts in 5.32 and 5.27 MeV of ²³²U peak and 5.34–MeV peak of ²²⁸Th corrected for background,

C_{5,42} = ²²⁸Th counts in 5.42–MeV peak corrected for background,

t = time in minutes for C_{5,3} and C_{5,42}, and

0.394 = known ratio of ²²⁸Th counts at 5.34 MeV to counts at 5.42 MeV.

85.2 Determine the ²³²U disintegration rate of the sample as follows:

$$D = ^{232}\text{C}/E \quad (13)$$

where:

D = sample disintegrations per minute, and

E = counter efficiency obtained by dividing the net counting rate obtained on a neptunium standard by the known disintegration rate for the standard.

85.3 Calculate the amount of ²³²U in nanograms per gram of ²³⁵U as follows:

$$^{232}\text{U}/^{235}\text{U}, \text{ ng/g} = D/4.65 \times 10^4 WF \quad (14)$$

where:

D = sample disintegrations per minute,

4.65 × 10⁴ = alpha activity of ²³²U in disintegrations per minute per nanogram,

W = weight of sample aliquot counted, g U, and

F = weight fraction ²³⁵U in sample.

86. Reliability

86.1 A 95 % confidence limit of ±16 % for a single determination has been obtained by analyzing eight separate aliquots from a uranium solution containing 100 μg/g ²³²U/²³⁵U.

DETERMINATION OF FISSION PRODUCT ACTIVITY

87. Scope

87.1 The gamma activity of fission products can be determined using Test Method C 1295. The beta activity of fission products can be determined according to Test Method C 799 by beta counting after separation of uranium with TBP.

DETERMINATION OF PLUTONIUM BY ION EXCHANGE AND ALPHA COUNTING

88. Scope

88.1 This test method (66) provides for the efficient carrier-free separation of plutonium activity from uranium. The separated plutonium activity can then be determined by alpha counting. Plutonium alpha activities of 300 d-m/g of uranium can be detected, and at the 3000-d-m/g of uranium level the method has a precision of about 15 to 20 %.

89. Summary of Test Method

89.1 Plutonium is commonly separated from uranium and most other elements by precipitation with fluoride using lanthanum as a carrier (67). For uranium of high-specific alpha

activity (for example, more than 1 %²³⁴U or ²³³U in isotopic composition), this method does not give satisfactory separation from uranium alpha activity. When this precipitation procedure is combined with the anion exchange procedure described by Wish and Rowell (68), a complete separation from uranium activity is achieved, and the plutonium is provided in a carrier-free residue that gives excellent counting characteristics.

89.2 Since the method combines two separation processes, based on entirely different principles, elements interfering in one are not likely to interfere in the other. Elements that can be carried down with plutonium in the flocculent lanthanum fluoride precipitate include: barium, neptunium, and thorium. Uranium is not precipitated but is carried along mechanically.

89.3 Of these elements, only neptunium and uranium will absorb along with the plutonium from 12 M HCl on a strongly basic anion-exchange resin. Barium and thorium will not absorb. Of the absorbed elements, only the plutonium is reduced and removed with the eluting agent; that is, ammonium iodide and hydroxylamine hydrochloride in 12 M HCl.

89.4 Evaporation of this eluate with HNO₃ leaves behind a very small, adhesive residue, that is ideally suited to alpha counting.

90. Apparatus

90.1 *Ion-Exchange Column*—The bottom half of a 10-mL pipet serves satisfactorily for this purpose.

90.2 *Proportional Counter*.

90.3 *Motor-Driven Stirrer*, made from a platinum wire sealed in a glass rod.

91. Reagents

91.1 *Dowex-1, X-8*, 500 to 100 mesh.

91.2 *Hydroxylamine Hydrochloride* (4 M)—Prepare a 4 M solution of hydroxylamine hydrochloride (NH₂OH·HCl).

91.3 *Lanthanum Nitrate Solution* (0.05 M)—Prepare a 0.05 M solution of lanthanum nitrate (La(NO₃)₃).

91.4 *Nitric Acid-Hydrochloric Acid Wash Solution* (1 N HNO₃ and 5 N HF).

91.5 *Plutonium Nitrate [Pu(NO₃)₆] Standard Solution*, pure, of known alpha activity of about 6000 d·m/mL.

91.6 *Potassium Hydroxide* (KOH) 50 %, carbonate-free.

91.7 *Reducing Solution*—Concentrated HCl (sp gr 1.19), saturated with NH₂OH·HCl; the resulting solution is made 0.1 M with respect to ammonium iodide (NH₄I).

92. Procedure

92.1 Fume an aliquot containing up to 0.1 g of uranium with concentrated H₂SO₄ (sp gr 1.84) to remove the fluoride ion and nitrate ion.

92.2 Transfer the aliquot to a 15-mL centrifuge tube.

92.3 Add 2 mL of NH₂OH·HCl solution, and heat the solution for 20 min at 80°C.

92.4 Add 1 mL of the La(NO₃)₃ solution, and mix the plutonium solution thoroughly.

92.5 Add 1 mL of 1 + 1 HF and stir.

92.6 Centrifuge the mixture for 2 min, and decant the supernatant liquid. Wash the precipitate with 1 mL of

HNO₃-HF solution with the aid of the motor-driven stirrer. Then centrifuge the solution, decant the supernate, and repeat the washing process.

92.7 Add 1 mL of KOH solution, and wash the precipitate. Centrifuge the solution for 2 min, and decant the supernatant part. Wash the precipitate and centrifuge again with the caustic solution, and then wash once with water to remove excess KOH.

92.8 Dissolve the precipitate with 2 to 3 mL of concentrated HCl (sp gr 1.19) containing a trace of HNO₃ [one drop of concentrated HNO₃ (sp gr 1.42) per 15 mL of concentrated HCl (sp gr 1.19)].

92.9 Prepare an ion-exchange column with Dowex-1 by pouring enough resin slurry into the column to give a resin bed about 15 cm high. Pass 10 mL of concentrated HCl (sp gr 1.19) through the column.

92.10 Pass the solution of the dissolved precipitate through the ion-exchange column at 4 drops/min (a slight vacuum will be required to maintain this rate of flow). Wash the resin with 5 mL of concentrated HCl (sp gr 1.19).

92.11 Elute the absorbed plutonium with 10 mL of reducing solution.

92.12 Add 2 to 3 drops of concentrated HNO₃ (sp gr 1.42) to the eluate, and evaporate it to dryness. Dissolve the residue with 2 to 3 drops of concentrated HNO₃ (sp gr 1.42), and rinse the sides of the beaker with 1 mL of water.

92.13 Transfer the solution to a counting planchet and evaporate to near dryness. Rinse the beaker twice with 1 mL of water; transfer the washings to the planchet and evaporate to dryness.

92.14 Alpha count the residue on a proportional counter.

92.15 Convert the alpha counts to disintegrations using a geometry and recovery factor determined by analyzing known amounts of plutonium activity by the above procedure. Recoveries of 90 to 100 % of 600 dis/min of plutonium activity should be achieved.

DETERMINATION OF PLUTONIUM BY EXTRACTION AND ALPHA COUNTING

93. Scope

93.1 This thenoyltrifluoroacetone (TTA) test method covers the determination of total plutonium in UF₆. Plutonium can be quantitatively and selectively extracted from an aqueous solution into a TTA-xylene solution.

94. Summary of Test Method

94.1 Plutonium-bearing UF₆ is hydrolyzed using a nitric acid-aluminum nitrate solution. The plutonium is then reduced with hydroxylamine hydrochloride to Pu⁺³, oxidized to Pu⁺⁴ with sodium nitrite, and extracted into TTA. Removal from TTA is with nitric acid. The plutonium-bearing aqueous phase is then evaporated to dryness on appropriate surfaces for counting gross alpha. Counting rates are compared to those of known standards to determine total plutonium. A tracer may also be used to check the recovery rate after the extraction.²³⁶Pu has been found suitable.

95. Interferences

95.1 There is no appreciable interference due to uranium and thorium; however, neptunium is not quantitatively separated from the plutonium in the extraction procedure. If prepared sample disks have appreciable alpha counts, an alpha energy analysis should be performed and a neptunium correction applied when necessary. For samples counting near the detectability level, the alpha energy scan is useless since sensitivity is inadequate to distinguish between neptunium and plutonium.

96. Apparatus

96.1 *Alpha Counter* with a background counting rate of 5 cpm or less is recommended. Either a proportional counter or parallel-plate alpha counter is suitable.

96.2 *Alpha Energy Analyzer* is necessary for checking the selectivity and recovery rate of the extraction process.

96.3 *Equipment for Agitating Solutions* is desirable. A variable-speed laboratory shaker or a bank of extraction cells and stirrers will suffice.

97. Reagents

97.1 *Thenoyltrifluoroacetone (TTA) Solution (0.5 M)*—Dissolve 111 g of TTA in 1 L of xylene.

97.2 *Hydroxylamine Hydrochloride Solution (1M)*—Dissolve 69.5 g of $\text{NH}_2\text{OH}\cdot\text{HCl}$ in 1 L of water.

97.3 *Sodium Nitrite Solution (1M)*—Dissolve 69 g of NaNO_2 in 1 L of water (prepare daily).

97.4 *Aluminum Nitrate (2 M)*—Dissolve 187.5 g of $\text{Al}(\text{NO}_3)_3\cdot 9\text{H}_2\text{O}$ in 250 mL of 2 M HNO_3 .

97.5 *Nitric Acid (6 M)-Aluminum Nitrate (0.1 M) Solution*—Add 375.5 mL of HNO_3 and 37.51 g of $\text{Al}(\text{NO}_3)_3$ to 1 L of water.

98. Procedure

98.1 Hydrolysis:

98.1.1 Hydrolyze a sample aliquot containing 5 g of uranium as UF_6 using 250 mL of 6 M HNO_3 -0.1 M $\text{Al}(\text{NO}_3)_3$ solution.

98.1.2 Hydrolyze a standard of plutonium-free UF_6 with the above solution, using 50 mL of the hydrolyzing solution per gram of uranium.

98.2 Extraction:

98.2.1 Transfer duplicate 50-mL aliquots from the prepared sample solution to 150-mL beakers. (For each group of samples, prepare a blank and a spike solution from the plutonium-free uranium standard. The blank is a 50-mL aliquot of the uranium standard in a 150-mL beaker. The spike is a similar aliquot spiked with 2400-dpm plutonium.)

98.2.2 Evaporate sample, blank, and spike solutions to dryness slowly on a hot plate and treat identically throughout the remainder of the procedure.

98.2.3 Flame the solid residue to eliminate fluorides.

98.2.4 Use approximately 10 mL of 2 N HNO_3 to put the solid residue back in solution.

98.2.5 Add 4 mL of 2 M $\text{Al}(\text{NO}_3)_3$ -2 M HNO_3 .

98.2.6 Add 2 mL of 1 M $\text{NH}_2\text{OH}\cdot\text{HCl}$ solution.

98.2.7 Stir the solution and allow to stand in a water bath at 80°C for 5 min.

98.2.8 Remove the sample from the water bath, and add 8 mL of 1 M NaNO_2 solution cautiously. Stir the solution, allow to stand for 5 min, and then transfer to an extraction cell.

98.2.9 Add 20 mL of 0.5 M TTA solution in xylene, and stir the solution for 15 min.

98.2.10 Discard the aqueous phase.

98.2.11 Wash the organic phase four times with approximately 15 mL of 2 M HNO_3 . Perform the washings by adding wash solution, stirring a few seconds, and discarding the aqueous phase. As an alternative to the reextraction of Pu in the aqueous phase, a direct deposition of the organic phase may be performed.

98.2.12 Add 4 mL of 8 M HNO_3 to the organic phase. (8 M HNO_3 may be replaced with 0.6 M HF for extracting plutonium out of the organic phase.)

98.2.13 Stir the solution for 15 min.

98.2.14 Withdraw the aqueous phase containing plutonium.

98.2.15 Pipet a 1-mL aliquot of plutonium-bearing solution onto a stainless steel alpha-counting disk, and evaporate to dryness under a heat lamp. (Stainless steel disks may be replaced by stainless steel dishes.)

98.2.16 Heat the disk over open flame to red heat and cool.

98.3 Counting:

98.3.1 Count the sample, blank, and spike disks for gross alpha.

98.3.2 In case of doubt concerning selectivity of extraction, perform an alpha energy scan to assure that the sample count is due to plutonium.

99. Calculations

99.1 Since each sample aliquot contains 1 g of uranium, the following expressions hold:

$$\text{Pu alpha cpm/gU} = A_O/GF \times (S - B)/(A_S - B) \quad (15)$$

where:

A_O = alpha disintegrations per minute in spike aliquot,

GF = geometry factor,

A = alpha cpm from sample disk,

B = alpha cpm from blank disk, and

A_S = alpha cpm from spike aliquot disk.

99.2 Plutonium alpha activity in disintegrations per minute per gram of uranium may be obtained by multiplying the result in Eq 15 by a geometry factor that is found by counting a plutonium standard of known disintegration rate. With most plates, this factor is 2.

99.3 Calculate parts per billion plutonium as follows:

$$\text{ppb Pu} = ((\text{Pu alpha cpm})/\text{gU})/(136)/GF \quad (16)$$

where:

ppb Pu = parts per billion plutonium on a uranium basis, and

136 = specific activity for one nanogram of ^{239}Pu .

100. Reliability

100.1 The procedure as described has a 95 % symmetrical confidence level of ± 10 % at alpha rates greater than about 136 dpm/g uranium.

100.2 By using larger sample aliquots and plating more than 1 mL of extracted solution, concentrations as low as 8 dpm/g

of uranium may be measured to a 95 % symmetrical confidence interval of ± 20 % of the value.

DETERMINATION OF NEPTUNIUM BY EXTRACTION AND ALPHA COUNTING

101. Scope

101.1 The thenoyltrifluoroacetone (TTA) test method covers to the determination of ^{237}Np in UF_6 . Neptunium can be selectively extracted from an aqueous solution into a TTA-xylene solution, and a ^{239}Np tracer technique can be used to measure extraction losses; thereby, eliminating the need for a more laborious quantitative extraction.

102. Summary of Test Method

102.1 Neptunium-bearing UF_6 is hydrolyzed using a nitric acid-aluminum nitrate solution. The resulting solution is spiked with a ^{239}Np tracer, brought to dryness, and flamed to rid the residue of fluorides. Residue is dissolved with hydrochloric acid, the neptunium reduced to Np^{+4} , and extracted into TTA. Neptunium is recovered from TTA in nitric acid as the Np^{+5} ion. The neptunium-bearing solution is evaporated to dryness on appropriate counting disks, and the necessary counting is performed.

103. Interferences

103.1 There is no radiochemical interference of consequence. Uranium, thorium, and plutonium are essentially removed in the extraction procedure. An alpha energy scan is optional to preclude interference.

104. Apparatus

104.1 *Alpha Counter* with a background counting rate less than 5 cpm is recommended. Either a proportional counter or a parallel-plate alpha counter is suitable.

104.2 *Gamma Scintillation Spectrometer*, required for the ^{239}Np tracer. A single-channel analyzer is adequate, with a multichannel instrument being optional.

104.3 *Alpha Energy Analyzer*, optional for checking the selectivity of the extraction process.

104.4 *Equipment for Agitating Solutions*, desirable. Extraction cells or separatory funnels will suffice.

105. Reagents

105.1 *Hydrochloric Acid (1 M)*—Prepare a 1 M solution of hydrochloric acid (HCl).

105.2 *Nitric Acid (HNO_3) (6 M)*—*Aluminum Nitrate [$\text{Al}(\text{NO}_3)_3$] (0.1 M) Solution*.

105.3 *Reducing Solutions*—150 mL of 5 M hydroxylamine hydrochloride ($\text{NH}_2\text{OH}\cdot\text{HCl}$) + 250 mL of 2 M hydrochloric acid (HCl) + 100 mL of 1.5 M ferrous chloride (FeCl_2). The solution is unstable, therefore, store it in a dark bottle and prepare every two weeks.

105.4 *Thenoyltrifluoroacetone (TTA) (0.5 M)*—Dissolve 111 g of TTA in 1 L of xylene solution.

106. Procedure

106.1 *Preparation of ^{239}Np Tracer (see note below)*:

NOTE 19— ^{239}Np can also be obtained from a purchased ^{243}Am solution. Np and Am can be separated on a ion exchange resin.

106.1.1 Encapsulate aliquots of 100 mg normal or depleted U_3O_8 in high-silica ampules and expose for 10 min to a nominal neutron flux of $2 \times 10^{14}\text{n/cm}^2\cdot\text{s}$.

106.1.2 Break the ampules and put the contents in solution with 6 M HNO_3 .

106.1.3 The extraction procedure for ^{239}Np tracer is the same as that for extracting ^{237}Np from sample solutions (see 105.3).

106.1.4 With a ^{239}Np half-life of 2.3 days, the usable life of a batch of tracer is about 2 weeks. (The tracer technique gives greater accuracy and precision with a minimum of analytical effort; however, the analysis can be performed without ^{239}Np . If tracer is not used, ^{237}Np standards should be run through the extraction procedure to determine a loss correction and the procedural steps performed methodically to assure uniform losses.)

106.2 Preparation of Sample:

106.2.1 Hydrolyze a sample aliquot containing 5 g of uranium as UF_6 using 250 mL of 6 M HNO_3 -0.1 M $\text{Al}(\text{NO}_3)_3$ solution.

106.2.2 Transfer duplicate 50-mL aliquots from the hydrolyzed solution to 150-mL beakers.

106.2.3 Add 2 mL of tracer solution to each aliquot (adjust the concentration of ^{239}Np tracer solution by appropriate dilution to give about 1000 cpm/mL when the scintillation counter is accepting photons from the 0.28-MeV gamma peak).

106.3 TTA Extraction:

106.3.1 Bring the spiked sample aliquots to dryness slowly on a hot plate to prevent spattering.

106.3.2 Heat each residue over an open flame until it becomes burnt orange color to remove fluorides and nitrates.

106.3.3 Cool the residue and put in solution with approximately 30 mL of 1 M HCl.

106.3.4 Add approximately 15 mL of reducing solution, and allow the solution to digest for 5 to 10 min.

106.3.5 Transfer the sample to an extraction cell, add 15 mL of TTA-xylene, and stir the resulting mixture for 20 min. (Replace xylene by benzene if desired.)

106.3.6 Discard the aqueous phase.

106.3.7 Wash the organic phase three times with 1 M HCl. Wash by adding HCl, stir $\frac{1}{2}$ min, and discard the aqueous phase.

106.3.8 Add 5 to 10 mL of 8 M HNO_3 to the organic phase, and stir the resulting mixture for 20 min.

106.3.9 Withdraw the aqueous phase, containing neptunium, and bring to dryness on a hot plate.

106.3.10 Repeat 106.3.3 through 106.3.7.

106.3.11 Wash the organic phase twice as in 106.3.7 except with 0.05 M HNO_3 .

106.3.12 Add 4 mL of 8 M HNO_3 to the organic phase, and stir the resulting mixture for 20 min.

106.3.13 Withdraw the aqueous phase, containing neptunium.

106.4 Sample and Tracer Disk Preparation:

106.4.1 *Sample Disk*:

106.4.1.1 Pipet 2 mL of the sample solution onto a stainless steel disk and allow to dry under a heat lamp.

106.4.1.2 Heat the disk to red heat over an open flame and cool.

106.4.2 Tracer Disk:

106.4.2.1 Pipet 1 mL of tracer solution onto a stainless steel disk and allow to dry under a heat lamp.

106.4.2.2 Heat the disk to red heat over an open flame and cool.

106.5 Counting:

106.5.1 Count the sample disks to determine net alpha counts per minute.

106.5.2 Count the sample and tracer disks to determine net gamma activity (counts/min) due to the 0.28-MeV ²³⁹Np peak.

106.5.3 An alpha energy scan is optional to certify that all alpha activity is due to ²³⁷Np.

107. Calculations

107.1 Each sample aliquot contains 1 g of uranium. If *A* equals the net ²³⁷Np alpha count per minute on the sample disk, *B* equals the net gamma count of the ²³⁹Np spike, and *C* equals the net ²³⁹Np gamma count extracted; the following equation gives ²³⁷Np alpha concentration in sample.

$$^{237}\text{Np alpha cpm/gU} = AB/C \quad (17)$$

107.2 Neptunium alpha activity in disintegrations per minute per gram of uranium may be obtained by multiplying the result in Eq 17 by a geometry factor that is found by counting a neptunium standard of known disintegration rate. With most standard plates or disks, this factor is 2. Calculate as follows:

$$\text{ppm Np} = ((\text{Np alpha cpm})/\text{gU})/((1562)/(GF)) \quad (18)$$

where:

ppm Np = parts per million neptunium on a uranium basis,

1562 = specific activity for 1 µg of ²³⁷Np, and

GF = geometry factor.

108. Reliability

108.1 The procedure has a 95 % symmetrical confidence interval of ± 10 % at alpha rates greater than about 156 dpm/g of uranium.

108.2 At 16 dpm/g uranium, the confidence interval is ± 30 %.

108.3 The lower limit of detectability is about 4 dpm/g of uranium.

ATOMIC ABSORPTION DETERMINATION OF CHROMIUM SOLUBLE IN URANIUM HEXAFLUORIDE

109. Scope

109.1 A test method is presented for the determination of chromium, soluble in UF₆, in the concentrations of 0.2 to 100 µg/g (uranium basis).

110. Summary of Test Method

110.1 The UF₆ is filtered through a porous filter (see procedure on subsampling, Sections 6 to 9), and the filtered

sample is hydrolyzed in deionized water. The chromium in the hydrolyzed UF₆ solution is separated from the uranium, with or without prior concentration, with an *n*-tributyl phosphate (TBP)-xylene mixture, leaving the chromium in the aqueous phase. The chromium is then determined by atomic absorption spectroscopy after dilution to a standard volume. Combining atomic absorption spectroscopy with solvent extraction of the chromium has two advantages: (1) uranium matrix effects are eliminated from the atomic absorption spectrometry and (2) radioactivity contamination problems arising from aspirating uranium solutions are eliminated.

110.2 Two extraction techniques are presented. In Method A, a sample solution containing 1 g of uranium is used and does not include a concentration step prior to extraction. Therefore, the detection limit is not as low as Method B, that includes a 5-g uranium sample and a concentration step prior to the extraction. Method A, that has a detection limit of 2 µg/g (uranium basis), is the preferred method because of its simplicity. However, if a lower detection limit is required, Method B should be used. Method B has a detection limit of 0.2 µg/g (uranium basis).

110.3 Boric acid is used in both Method A and Method B to form a complex with the fluoride prior to the extraction. A TBP-xylene mixture is used in both methods to extract the uranium, leaving the chromium in the aqueous phase, in which the final atomic absorption determination is made.

111. Interferences

111.1 In relatively pure UF₆, that is normally analyzed by this method, there is usually no problem with interferences.

112. Apparatus

112.1 *Atomic Absorption Spectrophotometer*, as described in Proposed Recommended Practices for Atomic Absorption Spectrometry.

113. Reagents

113.1 *Boric Acid* (H₃BO₃), reagent grade.

113.2 *Boric Acid Solutions*, saturated. Prepare by dissolving reagent-grade boric acid in deionized water until an excess of boric acid crystals remains undissolved.

113.3 *Chromium, Stock Solution, 1000 µg/mL*—Dissolve 3.7349 g of potassium chromate (K₂CrO₄) in 1 L of deionized water or use commercially¹³ available standard solutions.

113.4 *n-Tributyl Phosphate*, purified.

113.5 *n-Tributyl Phosphate-Xylene Mixture (1 + 2)*—Mix 1 volume of TBP with 2 volumes of reagent-grade xylene.

113.6 *Xylene* (C₈H₁₀), reagent grade.

114. Procedure

114.1 *Method A*:

114.1.1 Hydrolyze the filtered UF₆ sample with chilled deionized water in accordance with 17.1 to 17.14.2.

114.1.2 Transfer an aliquot of the sample that contains 1 g of uranium to a 125-mL separatory funnel.

¹³ Fisher Scientific Co., 711 Forbes Ave., Pittsburgh, PA 15219 is a suggested vendor.

114.1.3 Add 10 mL of saturated boric acid solution and enough concentrated HNO₃ to make the solution 2.5 M in HNO₃.

114.1.4 Add 25 mL of the (1 + 2) TBP-xylene mixture and shake for 30 s.

114.1.5 Allow the layers to separate, and transfer the bottom (aqueous) layer to a second 125-mL separatory funnel.

114.1.6 Repeat 114.1.4 with the aqueous portion in the separatory funnel.

114.1.7 Allow the layers to separate and collect the aqueous layer in a 50-mL volumetric flask.

114.1.8 Dilute to volume with water.

114.2 *Method B:*

114.2.1 Hydrolyze the filtered UF₆ sample with chilled deionized water in accordance with 17.1 to 17.14.2.

114.2.2 Weigh 3 g of boric acid into a 100-mL beaker.

114.2.3 Transfer an aliquot of the sample that contains 5 g of uranium to the beaker, and concentrate the mixture to less than 15 mL on a hot plate.

114.2.4 Add 10 mL of concentrated HNO₃, and transfer with minimum water to a 125-mL separatory funnel.

114.2.5 Add 50 mL of the (1 + 2) TBP-xylene mixture and shake for 30 s.

114.2.6 Allow the layers to separate, and transfer the lower (aqueous) layer to a second 125-mL separatory funnel.

114.2.7 Repeat 114.2.5 with the aqueous portion. Allow the layers to separate.

114.2.8 Transfer the lower (aqueous) layer to a 25-mL volumetric flask, and dilute to volume with water.

114.3 Analyze the aqueous extract by atomic absorption as follows:

114.3.1 Prepare the instrument for chromium analysis as outlined in the instrument manufacturer's atomic absorption manual.

114.3.2 Zero the instrument with deionized water.

114.3.3 Calibrate the instrument by preparing standards from UO₂F₂ solutions that have been spiked with known amounts of chromium. The standards are then extracted as outlined above. (Calibration is performed each time samples are analyzed.)

114.3.4 Analyze the sample extracts. Determine the concentration of chromium in the extracts from the calibration.

115. Precision and Bias

115.1 The relative standard deviation of a single analysis by this test method is approximately 10 % at the 2-μg/g concentration level, and the bias is + 1.5 % (relative). (A minimum of ten replicate measurements were used to determine the standard deviation and the bias of the test method.)

ATOMIC ABSORPTION DETERMINATION OF CHROMIUM INSOLUBLE IN URANIUM HEXAFLUORIDE

116. Scope

116.1 A test method is presented for the determination of chromium, insoluble in UF₆, by atomic absorption spectroscopy. The detection limit achieved using this technique is

dependent upon the amount of sample filtered through the filter. A detection limit of 0.5 μg/g has been obtained using a 10-g sample.

117. Summary of Test Method

117.1 The liquid UF₆ sample is filtered through a porous nickel filter (see Sections 6 to 9), and both the filter and the residue are dissolved in dilute nitric acid for the analysis. The amount of UF₆ filtered is determined by the detection limit required. The usual sample will vary between 10 and 50 g. The dissolved solution is diluted so as to contain a final nickel concentration of 1 % and an ammonium chloride concentration of 2 %. The chromium is then determined by atomic absorption spectrophotometry.

117.2 In the atomic absorption analysis, nickel suppresses the chromium response. To minimize this effect, it is necessary to add ammonium chloride. To further compensate for this and other matrix effects, it is necessary to prepare standard chromium solutions that contain both 1 % nickel and 2 % ammonium chloride. The concentration range of the standards prepared should bracket the expected concentrations in the samples.

118. Interferences

118.1 The interference of nickel and other metallic elements is controlled by the addition of ammonium chloride to suppress ionization.

119. Apparatus

119.1 *Atomic Absorption Spectrophotometer*, as described in Proposed Recommended Practices for Atomic Absorption Spectrometry.

120. Reagents

120.1 *Ammonium Chloride Solution, 20 %*—Dissolve 200 g of ammonium chloride, reagent grade, in deionized water and dilute to 1 L.

120.2 *Chromium Standard Solutions*—Prepare 100-mL quantities of a 1 % nickel solution containing 50, 30, 20, 10 and 5 μg of chromium. Add 10 mL of the ammonium chloride stock solution to each standard solution before diluting to volume.

120.3 *Chromium Stock Solution, 1000 μg/mL*—Dissolve 3.7349 g of potassium chromate (K₂CrO₄) in 1 L of deionized water or use commercially¹⁴available standard solutions.

120.4 *Nickel Solution, 10 %*—Dissolve 100 g of spectrographically pure nickel powder in 500 mL of deionized water and 50 mL of concentrated HNO₃. Heat until dissolution is complete and dilute to 1 L with deionized water.

121. Procedure

121.1 Filter sufficient UF₆ to obtain the desired detection limit (see Sections 6 to 9).

NOTE 20—The detection limit of the atomic absorption technique is 0.05 μg chromium/mL in a 1 % nickel solution. When a 1-g filter is dissolved and diluted to 100 mL, the weight of chromium needed in the

¹⁴ Associated Electrical Industries slugs have been found satisfactory.

determination to report a positive value is in excess of 5 $\mu\text{g/g}$ uranium sample at this level would show 0.5 $\mu\text{g/g}$ chromium, while a 50-g uranium sample would show 0.1 $\mu\text{g/g}$ chromium.

121.2 Dissolve the filter and residue in a minimum amount of (1 + 1) HNO_3 (about 10 mL).

121.3 Transfer the solution to a 100-mL volumetric flask (for a 1-g filter), add 10 mL of the ammonium chloride solution, and dilute to volume with deionized water.

NOTE 21—For filters weighing other than 1 g, make appropriate dilution so that the final solution will contain 1% nickel and 2% ammonium chloride.

121.4 Analyze the diluted sample by atomic absorption as follows:

121.4.1 Prepare the instrument for chromium analysis as outlined in the instrument manufacturer's atomic absorption manual.

121.4.2 Zero the instrument with a blank 1% nickel solution which contains 2% ammonium chloride.

121.4.3 Determine the chromium by standard atomic absorption techniques, comparing the sample measurements to those of the prepared standards in the same concentration region.

122. Precision and Bias

122.1 The relative standard deviation of a single analysis using this test method is approximately 10%. (Ten replicate measurements were made to determine the standard deviation of the procedure. A bias could not be computed, since no certified standard was available.)

DETERMINATION OF TECHNETIUM-99 IN URANIUM HEXAFLUORIDE

123. Scope

123.1 Technetium can be determined by ICP-MS (see Test Method C 1287). The following test method uses extraction and beta counting.

124. Summary of Test Method

124.1 The sample, to which a nonradioactive rhenium carrier has been added, is dissolved in HNO_3 and the solution is evaporated almost to dryness at low temperature (do not boil). A solution of potassium carbonate (K_2CO_3) and hydrogen peroxide (H_2O_2) is added, and the technetium is extracted into methyl ethyl ketone. The ketone is evaporated, and the residue of perhenate and pertechnetate is dissolved in water. Stable cerium, cesium, ruthenium, and strontium are added to the residual solution to dilute any radioactive trace quantities of these elements that may precipitate with the ^{99}Tc . The technetium and rhenium are precipitated with tetraphenyl arsonium chloride, weighed in a tared stainless steel dish, and beta counted. The beta counting rate is corrected for the recovery indicated by the rhenium carrier, and compared to that of a ^{99}Tc standard.

125. Apparatus

125.1 *Automatic Low-level Beta Counter.*

125.2 *Counter Standard*, known activity of ^{90}Sr - ^{90}Y , or some other well-characterized beta standard.

125.3 *Centrifuge.*

125.4 *Stainless Steel Dish*, 25 mm in diameter and 6.4 mm deep.

125.5 *Separatory Funnel*, 250 mL.

126. Reagents

126.1 *Ammonium Hydroxide (NH_4OH)*, concentrated.

126.2 *Boric Acid Solution*, saturated.

126.3 *Ferric Nitrate Solution*—Dissolve 18 g of $\text{Fe}(\text{NO}_3)_3 \cdot 9\text{H}_2\text{O}$ in distilled water and dilute to 250 mL.

126.4 *Hydrochloric Acid (HCl)*, reagent grade, concentrated.

126.5 *Hydrogen Peroxide (H_2O_2)*, 30%.

126.6 *Methyl Ethyl Ketone*, reagent grade.

126.7 *Methyl Orange Indicator Solution.*

126.8 *Potassium Carbonate, 3 M*—Dissolve 414.6 g of K_2CO_3 in distilled water and dilute to 1 L.

126.9 *Potassium Perrhenate*—Dissolve 2 g of KReO_4 in distilled water and dilute to 1 L.

126.10 *Stable Solution of Cerium, Cesium, Ruthenium, and Strontium*—Dissolve 7.75 g of $\text{Ce}(\text{NO}_3)_3 \cdot 6\text{H}_2\text{O}$, 6.25 g of RuCl_3 , 7.50 g of $\text{SrCl}_2 \cdot 6\text{H}_2\text{O}$, and 2.75 g of CsNO_3 in distilled water and dilute to 1 L.

126.11 *Technetium Standard in a Basic Aqueous Solution.*

126.12 *Tetraphenyl Arsonium Chloride (TPA)*—Dissolve 4 g of $(\text{C}_6\text{H}_5)_4\text{AsCl}$ in distilled water and dilute to 250 mL.

127. Procedure

127.1 *Sample Preparation:*

127.1.1 *Hydrolyzed UO_2F_2 Sample Preparation:*

127.1.1.1 Pipet 3 mL of KReO_4 solution into a beaker.

NOTE 22—**Caution:** The final precipitate of $(\text{C}_6\text{H}_5)_4\text{AsReO}_4$ must not exceed 14 mg to prevent shielding of ^{99}Tc .

127.1.1.2 Pipet 10 mL of the sample into the same beaker.

127.1.1.3 To complex the fluorides present, add 3 mL of saturated boric acid solution per gram of UO_2F_2 .

127.1.1.4 Make basic by adding 10 mL of 3 M K_2CO_3 solution, and stir until the precipitate dissolves. (Uranyl hydroxide is soluble in K_2CO_3 .) Add 2 mL of 30% H_2O_2 to oxidize technetium to +7. (Technetium must be present as Tc (+7) before extracting into ketone (69).)

127.1.2 *Control Sample Preparation:*

127.1.2.1 Pipet 3 mL of KR_eO_4 solution into a beaker.

NOTE 23—**Caution:** The final precipitate of $(\text{C}_6\text{H}_5)_4\text{AsReO}_4$ must not exceed 14 mg to prevent shielding of ^{99}Tc .

127.1.2.2 Pipet 10 mL of a ^{99}Tc solution of known activity level (100 dis/min/mL) into the same beaker.

127.1.2.3 Make basic by adding 10 mL of 3 M K_2CO_3 solution. Add 2 mL of 30% H_2O_2 to oxidize the technetium to (+7) valence. (Technetium must be present as Tc (+7) before extracting into ketone.)

127.1.3 *Extraction:*

127.1.3.1 Transfer a sample in accordance with 127.1.1.1 and 127.1.2.1 to a separatory funnel, wash the beaker in accordance with 127.1.1.1 and 127.1.2.1 with approximately 10 mL of 3 M K_2CO_3 , and drain the washings into the separatory funnel.

127.1.3.2 Add approximately 50 mL of methyl ethyl ketone to the separatory funnel and shake for about 2 min. Release the pressure after several seconds of agitation.

127.1.3.3 Drain the aqueous phase into a salvage container, and save the ketone that contains the rhenium and technetium.

127.1.3.4 Wash the sides of the separatory funnel by shaking twice with 10-mL portions of 3 M K₂CO₃, and discard the washings.

127.1.3.5 Drain the ketone into a beaker.

127.1.3.6 Add 10 mL of distilled water to the same beaker in accordance with 127.1.3.5 and evaporate the ketone under heat lamps. (The water prevents the sample from going to dryness and the possible loss of Tc.)

127.1.4 *Precipitation:*

127.1.4.1 Transfer the solution to a 50-mL centrifuge tube. Wash the beaker with distilled water, and transfer the rinse solution to the tube.

127.1.4.2 Add three drops of concentrated HCl, five drops of the stable cerium, cesium, ruthenium, and strontium solution, and five drops of the ferric nitrate solution. Agitate slightly after each addition.

127.1.4.3 Precipitate Fe(OH)₃ by adding several drops of concentrated NH₄OH until the solution is basic to pH paper.

127.1.4.4 Filter the solution through No. 41 Whatman filter paper into another 50-mL centrifuge tube and discard the precipitate. (Technetium must be as Tc (+7) or else it will coprecipitate with the Fe(OH)₃.)

127.1.4.5 Add one drop of methyl orange indicator to the filtrate, and add HCl until the indicator turns red. Then add five extra drops of HCl.

127.1.4.6 Cool for 5 to 10 min in an ice bath, add 2 mL of TPA and stir (69).

127.1.4.7 Remove the solution from the ice bath, and centrifuge for 1 min at 3000 r/min.

127.1.4.8 Pour off the supernatant liquid. Wash the precipitate twice with approximately 10 mL of ice water.

127.1.4.9 Pour off the supernatant and dissolve the precipitate in 1 mL of acetone. Transfer the solution to a counting dish that has been weighed to ±0.1 mg.

127.1.4.10 Evaporate the precipitate to dryness under a heat lamp.

127.1.4.11 Weigh the dish, and calculate the net weight of the residual tetraphenyl arsonium perrhenate, (C₆H₅)₄AsReO₄.

127.1.4.12 Cover each dish with a layer of cellophane tape to prevent loss of the residue.

128. Counting

128.1 Beta count the counter standard until 30 000 counts are registered. Calculate the counting rate; it must be within ±2.5 % of the posted mean for the standard. (A typical value is 20 000 counts per minute (cpm).)

128.2 Beta count the sample and control sample.

128.3 Subtract the counter background (cpm) from both the sample and control sample counting rates to obtain the net cpm.

129. Calculations

129.1 Calculate rhenium carrier yield (*y*) for the sample and control sample as follows:

$$y = a/(b)(2.19) \quad (19)$$

where:

a = net sample weight in beta counting dish, mg, and

b = net weight of KReO₄ added, mg.

(If 1 mg of KReO₄ is precipitated with tetraphenyl arsonium chloride, 2.19 mg of (C₆H₅)₄AsReO₄ is formed.)

129.2 Calculate the geometry factor (*GF*) as follows:

$$GF = d/c \quad (20)$$

where:

d = disintegrations per minute (dpm) of ⁹⁹Tc control sample, and

c = net cpm of control sample corrected for yield.

129.3 Calculate the ⁹⁹Tc in the sample as follows:

$$\begin{aligned} \text{micrograms } ^{99}\text{Tc/grams sample} = \\ \frac{(s)(GF)/(y)}{(37\ 807)(\text{grams sample})} \end{aligned} \quad (21)$$

where:

s = net cpm of sample,

GF = geometry factor,

y = yield fraction of sample, and

37 807 = specific activity of ⁹⁹Tc in dpm/microgram.

130. Precision and Bias

130.1 The relative standard deviation of an analysis is 25 % of the value in the range 0.01 to 0.05 µg ⁹⁹Tc/g sample. A minimum of ten replicate measurements was performed.

131. Sensitivity

131.1 The lower limit of detection is 0.001 µg ⁹⁹Tc with the Omni/Guard Low Background beta counter.

METHOD FOR THE DETERMINATION OF GAMMA-ENERGY EMISSION RATE FROM FISSION PRODUCTS IN URANIUM HEXAFLUORIDE

132. Scope

132.1 This method has been discontinued. The gamma activity of fission products can be determined using Test Method C 1295. The beta activity of fission products can be determined according to Test Method C 799 by beta counting after separation of uranium with TBP.

DETERMINATION OF METALLIC IMPURITIES BY ICP-AES

133. Scope

133.1 This test method is applicable to the determination of metallic impurities in uranium hexafluoride.

133.2 The elements determined are aluminum (Al), barium (Ba), beryllium (Be), bismuth (Bi), calcium (Ca), cadmium (Cd), cobalt (Co), chromium (Cr), copper (Cu), iron (Fe), magnesium (Mg), manganese (Mn), sodium (Na), nickel (Ni),

lead (Pb), antimony (Sb), tin (Sn), vanadium (V), tungsten (W), zinc (Zn), and zirconium (Zr).

133.3 The detection limits range from 0.01 µg/gU to 0.6 µg/gU depending on the element.

133.4 This test method is also applicable to determination of metallic impurities in U₃O₈ and U-metal with no additional procedure changes.

134. Summary of Test Method

134.1 Uranium oxide, U₃O₈, generated in the pyrohydrolysis of uranium hexafluoride is dissolved in a solution of ammonium fluoride and nitric acid. The uranium is separated from the metallic impurities by solvent extraction using tri (2-ethylhexyl) phosphate diluted with heptane. The aqueous phase containing the metallic impurities is nebulized directly into the inductively coupled argon plasma and the metals are measured by emission spectroscopy (71, 72).

135. Interferences

135.1 Uranium is a spectral interference and must be separated from the elements of interest. A uranium concentration of <100 µg/mL in the analyte solution can be tolerated.

136. Instrumentation and Apparatus

136.1 Instrumentation:

136.1.1 *Inductively Coupled Plasma-Emission Spectrometer*—Direct reading (simultaneous) or scanning (sequential) with a spectral bandpass of 0.05 nm or less. Either pneumatic or ultrasonic aerosol generators may be used to introduce the sample solution to the plasma source. An interactive computer based data and control system may be used.

136.1.2 The nebulizer and spray chamber should be resistant to hydrofluoric acid. These should be made of TFE fluorocarbon or polypropylene. A TFE-fluorocarbon-lined sample introduction tube with a sapphire tip is required in the torch assembly.

136.2 Apparatus:

136.2.1 *Peristaltic pump*.

136.2.2 *Beakers and lids*, TFE-fluorocarbon, 50 mL.

136.2.3 *Sample analysis tubes*, graduated, plastic, 50 mL.

136.2.4 *Separatory funnels*, TFE-fluorocarbon, 125 mL.

137. Reagents

137.1 *Argon*—High purity gas derived from the head space gas over the liquid in a liquid argon cylinder is recommended.

137.2 *Ammonium Fluoride (1 % W/V)*—Dissolve 1.0 g of ammonium fluoride in 100 mL of water. Store in a plastic bottle.

137.3 *Nitric Acid (sp. gr. 1.42)*—Concentrated nitric acid (HNO₃).

137.4 *Nitric Acid (8M)*—Add 1 volume of concentrated HNO₃ to an equal volume of water.

137.5 *Nitric Acid (1.6M)*—Add 1 volume of concentrated HNO₃ to 9 volumes of water.

137.6 *Tri(2-ethylhexyl) phosphate [(C₈H₁₇O)₃PO]*—Technical grade (TEHP).

137.7 *Heptane [CH₃(CH₂)₅CH₃]*.

137.8 *TEHP-Heptane Solution (1:1 V/V), purified*—Add 25 mL TEHP to a 250 mL separatory funnel and dilute with 25 mL heptane. Add 75 mL of 8M HNO₃ to the funnel, stopper, and shake for 2 min. Discard the acid layer and retain the TEHP-heptane in the separatory funnel. This purification step is carried out immediately before use.

137.9 *Calibration Solutions*—Prepare several compatible multi-element standard solutions in 4M nitric acid by adding appropriate volumes of single element stock solutions prepared by dissolving metals or metal salts of high purity. Commercial stock solutions may be used but should be verified. Calibration solutions with Zr should contain 1 % hydrofluoric acid by volume. Element concentration range of the solution should be 1 to 100 µg/mL.

NOTE 24—To avoid precipitation of alkaline earth fluorides, do not mix multielement standard solutions with Zr solutions. Compatibility of mixing commercial stock solution should be verified.

137.10 *Uranium Oxide Standards*—U₃O₈ standards containing metallic impurities.

137.11 *Uranium Oxide (U₃O₈)*—High purity to be used as a blank. See Appendix X3 for preparation procedure.

138. Preparation of Apparatus

138.1 A set of suggested instrument operating parameters are given in Table 6. Operating parameters will vary with the type of instrument and the manufacturer's instructions should be followed.

138.2 A set of suggested analytical wavelengths is given in Table 7.

139. Calibration

139.1 Calibration:

139.1.1 Nebulize the multielement standard solutions, (see 137.9) to calibrate the instrument.

NOTE 25—The linear dynamic range should be established for each analytical channel and should cover the range expected in the samples.

139.1.2 Prepare calibration curves if automatic data processing equipment is not available.

140. Procedure

140.1 Sample Preparation:

140.1.1 Weigh a U₃O₈ sample containing 2 g of uranium to 0.001 g into a 50 mL TFE-fluorocarbon beaker.

NOTE 26—U₃O₈ sample from the pyrohydrolysis of UF₆ as described in 17.33.

TABLE 6 Suggested Instrument Operating Parameters for ICP-AES Analysis

Argon Gas Flows	Coolant 21 L/min Plasma 0.6 L/min Nebulizer 0.4 L/min
RF Power	Forward 1100 W Reverse <10 W
Vertical Observation Zone	16 mm above the load coil
Integration Time	2 × 7 s on-line 1 × 7 s on-background
Nebulizer	Fixed cross flow Solution uptake 1 mL/min
Peristaltic Pump	Solution uptake 1.1 mL/min

TABLE 7 Suggested Wavelengths for ICP Analysis

Element	Wavelength, nm	Alternate Wavelength, nm
Al	308.2	...
Ba	455.4	493.4
Be	313.0	...
Bi	223.1	...
Ca	393.3	317.9
Cd	228.8	226.5
Co	228.6	...
Cr	205.6	267.7
Cu	324.8	...
Fe	259.9	...
Mg	279.6	280.3
Mn	257.6	...
Mo	202.0	204.6
Na	589.0	...
Nb	316.3	...
Ni	231.6	...
Pb	220.4	...
Sb	217.6	...
Sn	190.0	...
Ta	222.2	228.9
Ti	334.9	...
V	292.4	...
W	207.9	224.9
Zn	213.9	...
Zr	343.8	339.2

140.1.2 Add 10 mL of concentrated HNO₃ and 3 mL of 1 % NH₄F solution to the sample.

140.1.3 Cover the beaker with a TFE-fluorocarbon lid and heat the sample at 100°C for 10 min. After the sample dissolves, cool the solution.

140.1.4 Add 10 mL of water and mix the solution. Transfer the sample to a 125 mL separatory funnel containing 50 mL of the purified TEHP-heptane solution. Wash the beaker with 1 to 2 mL of 8M HNO₃ and add the washings to the separatory funnel.

140.1.5 Stopper the separatory funnel and shake the funnel for 2 min. Allow the phases to separate.

140.1.6 Drain the aqueous phase into another 125 mL separatory funnel containing 50 mL of purified TEHP-heptane. Stopper and shake for 2 min. Allow the phases to separate.

140.1.7 Drain the aqueous phase into a graduated analysis tube and dilute to 40 mL with water. Cap the tube and mix thoroughly.

140.1.8 Run a series of U₃O₈ standards and a U₃O₈ blank using the above procedure.

140.2 Measurement:

140.2.1 Nebulize the extracted uranium blank and standards to verify chemical preparation and extraction efficiency and to establish a reagent blank.

140.2.2 Nebulize extracted sample solutions from 140.1.7.

141. Calculation

141.1 If automatic data processing is not available to calculate the metal concentrations on a uranium basis the calculation is as follows:

$$\text{Metal, } \mu\text{g/gU} = A \times 40/W(0.848) \quad (22)$$

where:

A = micrograms of metal per mL of the measured solution corrected for reagent blank,

W = weight of U₃O₈, in g.

142. Precision and Bias

142.1 *Precision*—The single operator and within laboratory precision of this method are shown in Table 8. Two precision estimates were made using the same U₃O₈ standard. The first estimate was based on eight separate determinations and the second estimate was based on five separate determinations.

142.2 *Bias*—A New Brunswick Laboratory reference material set (CRM No. 123, 18 Element Impurity Standard) was analyzed by this test method. Single analyses were made on CRM 123 (1-3) and duplicate analyses were made on CRM 123 (4-6). A comparison of the results to the reference values are shown in Table 9 and Table 10. Although the data are insufficient to establish an estimate of bias for the test method, the results compare very well with the reference values and fall within the range established by an inter-laboratory measurement program (73).

DETERMINATION OF MOLYBDENUM, NIOBIUM, TANTALUM, TITANIUM, AND TUNGSTEN BY ICP-AES

143. Scope

143.1 This test method is applicable to the determination of molybdenum, niobium, tantalum, titanium, and tungsten in uranium hexafluoride.

143.2 The limit of detection for each element is 0.1 μg/gU.

144. Summary of Test Method

144.1 Molybdenum, niobium, tantalum, titanium, and tungsten are separated from uranium by solvent extraction as their benzoylphenylhydroxylamine (BPHA) complexes into chloroform (17). The extract is evaporated to dryness and then wet ashed with nitric acid and sulfuric acid. The residue is ignited at 600°C and then dissolved in a mixture of hydrochloric and hydrofluoric acids and diluted with water. The solution is nebulized into an inductively coupled argon plasma and the metals are measured by emission spectroscopy (74, 71).

TABLE 8 Analysis of Mallinckrodt U₃O₈—Standard A by ICP-AES

Element	μg Element/g U				
	Certified Value	Mean and Standard Deviation			
		Run 1	Run 2		
Al	64	64	8	64	2
Ba	61	61	3	63	2
Be	4.9	4.9	0.4	5.4	0.2
Bi	4.9	4.9	0.3	4.5	0.4
Ca	53	53	3	59	2
Cd	0.6	0.6	0.1	0.7	0.2
Cr	47	47	3	50	3
Cu	7.8	7.8	0.9	8.9	1
Fe	43	43	2	48	2
Mg	10	10	0.8	12	2
Mn	5	4.9	0.5	5.2	0.4
Ni	69	69	4	75	4
Sn	30	28	6	26	3
Zn	13	13	3	19	3

TABLE 9 Analysis of NBL-CRM 123, U₃O₈ by ICP-AES

Element	Standard, µg Element/gU					
	123-1		123-2		123-3	
	Ref.	Found	Ref.	Found	Ref.	Found
Al	205	200	105	110	55	65
B	5.1	4.8	2.6	2.5	1.1	1.0
Cd	5.2	4.5	2.7	2.3	1.2	0.9
Ca	200	213	100	113	51	58
Cr	102	114	52	60	22	25
Cu	50	50	25	26	10.4	11
Fe	210	206	110	114	60	60
Pb	51	50	26	26	10.8	11
Mg	101	100	51	60	21	26
Mo	100	95	50	48	20	19
Ni	202	211	102	110	52	54
Na	400	362	200	187	100	99
Sn	51	50	26	26	11	10
V	50	48	25	24	10	9
Zn	202	223	102	116	52	58

TABLE 10 Analysis of NBL-CRM 123, U₃O₈ by ICP-AES

Element	Standard, µg Element/gU					
	123-4		123-5		123-6	
	Ref.	Found	Ref.	Found	Ref.	Found
Al	24	28	14	17	9	9
B	0.7	0.6	0.4	0.3	0.3	0.4
Cd	0.5	0.4	0.25	0.2	0.1	0.25
Ca	20	28	10	15	5	8
Cr	15	14	10	8	7	5
Cu	5	5	2.5	2.8	1	1
Fe	28	30	18	20	13	14
Pb	5	5	2.5	3	1	1.3
Mg	10	14	5	8	2	4
Mn	5	6	2.5	2.9	1	1
Ni	20	22	10	12	5	6
Na	30	43	20	19	10	12
Sn	5	7	2.5	2.5	1	1.5
V	5	4	2.5	1.8	1	0.4
Zn	20	22	10	12	5	6
Zr	20	24	10	12	5	7

145. Interferences

145.1 Uranium is a spectral interference and must be separated from the elements of interest. A uranium concentration of <100 µg/mL in the analyte solution can be tolerated.

146. Instrumentation and Apparatus

146.1 Instrumentation:

146.1.1 *Inductively Coupled Plasma-Emission Spectrometer*—Direct reading (simultaneous) or scanning (sequential) with a spectral bandpass of 0.05 nm or less. Either pneumatic or ultrasonic aerosol generators may be used to introduce the sample solution to the plasma source. An interactive computer based data and control system may be used.

146.2 Apparatus:

- 146.2.1 *Peristaltic pump*,
- 146.2.2 *Platinum dishes with lids*, 75 and 250 mL
- 146.2.3 *Separatory funnels with TFE-fluorocarbon stopcocks*, 250 mL
- 146.2.4 *Beakers and lids*, TFE-fluorocarbon, 250 mL
- 146.2.5 *Graduates*, plastic, 50 mL
- 146.2.6 *Sample analysis tubes*, graduated, plastic, 50 mL

146.2.7 *Automatic shaker with clamps*, to hold 250 mL separatory funnels.

147. Reagents

147.1 *Boric Acid Solution (10 %)*—Dissolve 100 g of boric acid, H₃BO₄, in 800 mL of hot water and dilute to one liter with water. Store this solution at 60°C.

147.2 *Ethyl Alcohol (C₂H₅OH)*, absolute.

147.3 *N-Phenylbenzohydroxamic Acid Solution (2 %)*—Dissolve 20 g n-phenylbenzohydroxamic acid (BPHA) in 1 L of ethyl alcohol.

147.4 *Chloroform (CHCl₃)*.

147.5 *Hydrochloric Acid (sp. gr. 1.19)*—Concentrated hydrochloric acid (HCl).

147.6 *Hydrofluoric Acid (48 %)*—Concentrated hydrofluoric acid (HF).

147.7 *Hydrofluoric Acid (2M)*—Add 83 mL of concentrated HF to 1 L with water. Store in a plastic bottle.

147.8 *Nitric Acid (sp. gr. 1.42)*—Concentrated nitric acid (HNO₃).

147.9 *Sulfuric Acid (sp. gr. 1.84)*—Concentrated sulfuric acid (H₂SO₄).

147.10 *Hydrochloric Acid—Hydrofluoric Acid Solution (1:5 V/V)*—Add one volume of concentrated hydrochloric acid (HCl) to five volumes of concentrated hydrofluoric acid (HF).

147.11 *Element Standard Stock Solutions (100µ g/mL)*—Dissolve 0.1000 g of high purity metal powder in 5 mL concentrated HF. Add concentrated HNO₃ dropwise to aid the dissolution. Dilute to 1.00 liter with 2M HF.

147.12 *Element Standard Solutions (10 µg/mL)*—Aliquot 100 mL of each standard stock solution into a one liter plastic volumetric flask and dilute to volume with 2M HF.

147.13 *Element Calibration Standards (0.1, 0.5, 1.0, and 5.0µ g/mL)*—Aliquot 1, 5, 10, and 50 mL of each element standard stock solutions into 4 one-liter plastic volumetric flasks. Add 25 mL of concentrated HNO₃ to each flask and dilute to volume with water.

147.14 *Uranium Standard Solution (100 g U/L)*—Dissolve 117.9 g of pure U₃O₈ with 100 mL of 8M HNO₃. Dilute to 1 L with water.

148. Preparation of Apparatus

148.1 A set of suggested instrument operating parameters are shown in Table 6. Operating parameters will vary with the type of instrument and the manufacturer's instructions should be followed.

148.2 A set of suggested analytical wavelengths are given in Table 7.

149. Calibration and Standardization

149.1 Uranium Calibration Standards:

149.1.1 Pipet two 50-mL aliquots of the 100 gU/L uranium standard solution into separate 250-mL TFE fluoro-carbon beakers.

149.1.2 Spike one uranium aliquot with 1 mL of the 10 µg/mL element standard solution, 146.12. The other uranium aliquot will be used as a blank.

149.1.3 Add 10 mL of concentrated HF to each solution.

149.1.4 Follow the procedure from 150.1.2 through 150.1.13.

149.2 *Calibration:*

149.2.1 Nebulize the multi-element standards 147.13 to calibrate the instrument.

NOTE 27—The linear dynamic range should be established for each analytical channel and should cover the range expected in the samples.

149.2.2 Prepare calibration curves if automatic data processing equipment is not available.

149.3 *Measurement:*

149.3.1 Nebulize the extracted uranium blank and standard to verify the chemical preparation, extraction and to establish a reagent blank.

149.3.2 Nebulize the extracted sample solutions.

150. Procedure

150.1 *Sample Preparation:*

150.1.1 Transfer an aliquot of UO₂F₂ solution containing 10 g of U to a 250 mL TFE fluorocarbon beaker.

NOTE 28—UF₆ sample hydrolyzed as described in 10.5.

150.1.2 Add 50 mL of 10 % boric acid solution to the beaker and mix thoroughly.

150.1.3 Transfer the sample solution to a 250 mL separatory funnel.

150.1.4 Add 5 mL of the 2 % BPHA-ethyl alcohol solution and mix. Allow the solution to stand for 10 min.

150.1.5 Add 20 mL of chloroform, stopper, and shake for 10 min using an automatic shaker.

150.1.6 Allow the layers to separate and drain the chloroform layer into a 75 mL platinum dish.

150.1.7 Evaporate the chloroform extract to dryness on a hot plate at about 80°C.

NOTE 29—Direct a gentle stream of air over the surface to aid evaporation and keep the solution from creeping.

150.1.8 Add 2 to 3 mL of concentrated HNO₃ to the residue. Wait until the residue turns black.

150.1.9 Add 0.5 mL of concentrated H₂SO₄ and evaporate to dryness.

150.1.10 Cover the platinum dish with a lid and ignite the residue at 600°C for 1 h.

150.1.11 Dissolve the residue in 1 mL the HCl-HF mixture by heating the solution gently.

150.1.12 Transfer the solution to a 50 mL analysis tube.

150.1.13 Add 1 mL of concentrated HNO₃ and dilute to 40 mL with water.

151. Calculation

151.1 If automatic data processing is not available, calculate the metal concentrations on a uranium basis. The calculation is as follows:

$$\text{Metal } \mu\text{g/gU} = \frac{A \times 40}{W} \quad (23)$$

where:

A = micrograms of metal per mL of the measured solution corrected for reagent blank.

W = weight of U in UO₂F₂ aliquot (147.1.1).

152. Precision and Bias

152.1 *Precision*—The single operator and within laboratory precision of this method is shown in Table 11. These estimates are based on four separate analyses on uranyl fluoride solutions containing 10 g of U spiked at two levels.

152.2 *Bias*—Since there is no accepted reference material for determining bias in these test methods for measuring Mo, Nb, Ta, Ti, and W in UF₆, no statement of bias is being made.

153. Keywords

153.1 analytical methods; mass spectrometry; radiochemistry; uranium hexafluoride

TABLE 11 Precision Estimates for ICP-AES Analysis

Concentration μ g/gU	Relative Standard Deviation, %				
	Mo	Nb	Ta	Ti	W
1.0	6.0	7.3	6.2	9.3	7.4
2.0	3.4	5.4	4.4	3.4	5.6

APPENDIX

(Nonmandatory Information)

X1. LIST OF ALTERNATIVE STAND ALONE ASTM TEST METHODS

C 1219 Arsenic in UF₆
 C 1287 Impurities in UO₂ by ICP-MS
 Elements measured include Li, Be, Mg, Al, Sc, Ti, V, Cr, Mn, Fe, Co, Ni, Cu, Zn, Ga, Ge, As, Se, Ru, Pd, Ag, Cd, In, Sn, Sb, Te, Cs, Ba, La, Ce, Pr, Nd, Sm, Eu, Gd, Tb, Dy, Ho, Er, Tm,

Yb, Lu, Hf, Ta, W, Rh, Os, Ir, Pt, Au, Hg, Tl, Pb, Bi, Th, Tc-99, B, Na, Si, P, K, and Ca

C 1295 Gamma Energy Emission from Fission Products in Uranium Hexafluoride

REFERENCES

- (1) *Uranium Hexafluoride: Handling Procedures and Container Criteria*, USAEC, August 1972 (ORO-651, Rev. 3), p. 21.
- (2) Wertz, R. J., *Sampling Influence on Uranium Hexafluoride Analysis*, Union Carbide Corp., Nuclear Division, Oak Ridge Gaseous Diffusion Plant, Oak Ridge, TN, Sept. 11, 1973 (K-L-6323).
- (3) "Subsampling Uranium Hexafluoride," *USAEC Selected Measurement Methods for Plutonium and Uranium in the Nuclear Fuel Cycle*, USAEC Division of Technical Information, 1963 (TID-7029).
- (4) Kienberger, C. A., *A Rapid and Precise Method for Determining Uranium in Uranium Hexafluoride*, Union Carbide Corp., Nuclear Division, Oak Ridge Gaseous Diffusion Plant, Oak Ridge, TN, July 6, 1955 (K-1199).
- (5) Petit, G. S., and Kienberger, C. A., *Preparation of Stoichiometric U₃O₈*, Union Carbide Corp., Nuclear Division, Oak Ridge Gaseous Diffusion Plant, Oak Ridge, TN, Nov. 30, 1960 (K-1424).
- (6) Voss, F. S., and Greene, R. E., *A Precise Potentiometric Titration Method for the Determination of Uranium*, Union Carbide Corp., Nuclear Division, Oak Ridge Gaseous Diffusion Plant, Oak Ridge, TN, Aug. 25, 1953 (K-1040).
- (7) Vita, O. A., Trivisonno, C. F., and Walker, C. R., *An Improved Titrimetric Method for the Precise Determination of Uranium*, Goodyear Atomic Corp., Portsmouth, OH, 1962 (GAT-471).
- (8) Hedge, W. D., *Empirical Cover-Gas and Air Buoyancy Correction for the Gravimetric Analysis of Uranium in Uranium Hexafluoride*, K-2051, Martin Marietta Energy Systems, Inc., May 1985.
- (9) Eberle, A. R., and Lerner, M. W., USAEC New Brunswick Laboratory, New Brunswick, NJ, March 1972, p. 5 (NBL-262).
- (10) Eberle, A. R., et al, USAEC New Brunswick Laboratory, New Brunswick, NJ, July 1970 (NBL-252).
- (11) Kauffman, G. F., and Tabor, C. D., "Isotopic Measurement of Uranium by Mass Spectrometry," *Proceedings of IAEA Symposium on Nuclear Material Management*, IARGA, Vienna, 1966.
- (12) Tabor, C. D., "Mass Spectrometric Determination of U-235 in Uranium Hexafluoride Using the Double-Standard Interpolative Technique," (TID-7029).
- (13) Tabor, C. D., "Mass Spectrometry for Uranium Isotopic Measurements," *IAEA, Rev. Ser.*, No. 5, 1960.
- (14) Kauffman, G. F., and Christopher, N. F., *Uranium Hexafluoride Isotopic Measurements Using an Interpolative Method*, Goodyear Atomic Corp., Portsmouth, OH Nov. 30, 1960 (GAT-291).
- (15) Kauffman, G. F., and Tabor, C. D., *Precision Mass Spectrometric Determination of Uranium Isotopic Composition*, Goodyear Atomic Corp., Portsmouth, OH, May 21, 1959 (GAT-T-664).
- (16) Smith, R. L., Shields, W. R., and Tabor, C. D., *An Interpolative Method of Assaying UF₆ with the Isotopic Mass Spectrometer*, Goodyear Atomic Corp., Portsmouth, OH, May 21, 1956 (GAT-171, Rev. 1).
- (17) Nier, A. O., "Mass Spectrometer for Isotopic and Gas Analysis," *Review of Scientific Instr.*, RSIN, 18, 1947, 398–411.
- (18) Langdon, A., and Kermicle, H. A., *An Automatic, Relative Mass Spectrometer for Uranium Isotopes*, Union Carbide Corp., Nuclear Division, Oak Ridge Gaseous Diffusion Plant, Oak Ridge, TN, May 20, 1963 (K-1444).
- (19) Langdon, A., and Hart, W. G., *A Sensitive Ratio Recorder for Mass Spectrometers*, Union Carbide Corp., Nuclear Division, Oak Ridge Gaseous Diffusion Plant, Oak Ridge, TN, March 18, 1959 (K-1292).
- (20) Jones, Ralph J., "Standard Reference Material," *USAEC Selected Measurement Methods for Plutonium and Uranium in the Nuclear Fuel Cycle* (TID-7029).
- (21) Lerner, M. W., *Colorimetric Determination of Traces of Bromine in Uranium Compounds*, New Brunswick Laboratory, New Brunswick, NJ, November 1958 (NBL-151).
- (22) Skvarla, J. E., *A Gas Analysis Mass Spectrometer*, Union Carbide Corp., Nuclear Division, Oak Ridge Gaseous Diffusion Plant, Oak Ridge, TN, Jan. 5, 1954 (K-1049).
- (23) Walker, C. R., Vita, O. A., and Sparks, R. W., *Microanalysis of Antimony, Iron, and Molybdenum in Nickel or Uranium by Atomic Absorption Spectroscopy*, Goodyear Atomic Corp., Portsmouth, OH, 1969 (GAT-T; 1479).
- (24) Southern, H. K., *The Determination of Forbidden Elements in X Compounds*, Imperial Chemical Industries, May 19, 1943 (Br-207-R/GC/1310).
- (25) Snell, F. D., and Snell, C. T., *Colorimetric Methods of Analysis*, Vol II-A, New York, Van Nostrand, 1959, pp. 570–586.
- (26) Rodden, C. J., ed., *Analytical Chemistry of the Manhattan Project, Division VIII-Vol I*, New York, McGraw-Hill, 1950, pp. 218–225.
- (27) Walker, C. R., *The Colorimetric Determination of Silicon or Phosphorous in Uranium Compounds*, Goodyear Atomic Corp., Portsmouth, OH, 1966 (GAT-T-1400).
- (28) Banks, C. V., and O'Laughlin, V. W., "Spectrophotometric Determination of Ruthenium with 1,10-phenanthroline," *Analytical Chemistry*, 29, p. 1412 (1957).
- (29) Vita, O. A., and Trivisonno, C. F., *Microdetermination of Ruthenium in Uranium Compounds*, Goodyear Atomic Corp., Portsmouth, OH, 1966 (GAT-T-1215, Rev. 1).
- (30) Rodden, C. J., *Current Procedures for the Analysis of UO₃, UF₄, and UF₆*, USAEC Division of Technical Information, February 1956 (TID-7003), pp. 115–117.
- (31) Rodden, C. J., *Current Procedures for the Analysis of UO₃, UF₄, and UF₆*, USAEC Division of Technical Information, TID-7003, February 1956, pp. 110–114.
- (32) Scribner, B. F., and Mullin, H. R., "Carrier-Distillation Method for Spectrographic Analysis and its Application to the Analysis of Uranium-Base Materials," *Journal of Research*, NBS, 1946, Vol 37, pp. 379–389.
- (33) Vogel, R. S., Novak, J. F., and Sheller, A. L., "A New Carrier Distillation System for the Spectrometric Analysis of Uranium Materials," *Process Development Quarterly Report*, Mallinckrodt Chemical Works, Uranium Division, Weldon Spring, Mo., Aug. 1, 1962 (MCW-1475), pp. 5–13.
- (34) Pepper, C. E., Pardi, A. J., and Atwell, M. G., "The Effects of Various Grades of Graphite Electrodes on the Carrier Distillation of Impurities in U₃O₈," *Applied Spectroscopy*, APSA, Vol 17, 1963, p. 114.
- (35) "Recommended Practices E 115, for Photographic Processing in Spectrochemical Analysis," *Methods for Emission Spectrochemical Analysis*, Fifth Edition, Am. Soc. Testing and Mats., 1968, pp. 131–139.
- (36) Rodden, C. J., *Analysis of Essential Nuclear Reactor Materials*, USAEC Division of Technical Information, March 1964, pp. 905–906 (LC 64-60035).
- (37) "Recommended Practice for Designation of Shapes and Sizes of Graphite Electrodes," Ref 38, E130-66, pp. 105–110.
- (38) Leslie, E. H., *Note on Improvements in Spectrochemical Techniques*, Union Carbide Corp., Nuclear Division, Oak Ridge Gaseous Diffusion Plant, Oak Ridge, TN, Dec. 28, 1948 (K-325).
- (39) Vita, O. A., Mullins, L. R., Jr., and Trivisonno, C. F., *The Colorimetric Micro-Determination of Titanium and Vanadium in Uranium Compounds Using Benzoylphenylhydroxylamine*, Goodyear Atomic Corp., Portsmouth, OH, 1963 (GAT-T-1085).
- (40) Ryan, D. E., "The Colorimetric Determination of Vanadium with Benzoylphenylhydroxylamine," *Analyst*, ALSTA, 1960, Vol 85, p. 569.
- (41) Ryan, D. E., "The Determination of Zirconium with Benzoylphenylhydroxylamine," *Canadian Journal of Chemistry*, CJCHA, Vol 38, p. 2488, 1960.
- (42) Langmyhr, F. J., and Hongslo, T., "Separation and Gravimetric Determination of Niobium, Tantalum and Titanium by Precipitation with *N*-Benzoyl-*N*-Phenylhydroxylamine," *Analytica Chimica Acta*, 1960, Vol 22, pp. 301–305.

- (43) Hillebrand, W. F., and Lundell, G. E. F., *Applied Inorganic Analysis*, 2nd Edition, New York, John Wiley and Sons, Inc., 1953, pp. 116–118.
- (44) Willard, H. H., and Diehl, H., *Advanced Quantitative Analysis*, New York, Van Nostrand, 1950, pp. 73–74.
- (45) Walker, C. R. and Trivisonno, C. F., *The Colorimetric Microdetermination of Tungsten in Uranium Compounds*, Goodyear Atomic Corp., Portsmouth, OH, July 24, 1963 (GAT-T-1120).
- (46) Gentry, C. H. R., and Sherrington, I. G., “The Photometric Determination of Tungsten,” *Analyst*, ALSTA, Vol 73, 1948, pp. 57–67.
- (47) Crouthamel, G. E., and Johnson, G. E., *Thiocyanate Spectrophotometric Determination of Molybdenum and Tungsten*, Argonne National Laboratory, Lemont, IL, February 1954 (ANL-5224).
- (48) Kraus, K. A., Moore, G. E., and Nelson, F., “Anion Exchange Studies. XXI. Th(IV) and U(VI) in Hydrochloric Acid. Separation of Thorium, Protactinium and Uranium,” *Journal of the American Chemical Society*, JACSA, Vol 78, 1956, p. 2692.
- (49) Nemodruk, A. A., and Kochetkova, N. E., “Photometric Study of the Reaction Between Thorium and Arsenazo III,” *Journal of Analytical Chemistry of the USSR (Eng. Trans)*, ZAKHA, Vol 17, 1962, p. 333.
- (50) Furtova, E. V., Sadova, G. F., Ivanova, V. N., and Zaikovskii, F. V., “Photometric Determination of Thorium in Natural Materials by Means of Arsenazo III,” *Journal of Analytical Chemistry of USSR*, Vol 19, pp. 82–84.
- (51) Kolthoff, I. M., and Elving, P. J., *Treatise on Analytical Chemistry, Part II*, New York, London, Interscience Publishers, 1963, Vol 8, pp. 40–41.
- (52) Wang, M. S., and Cave, W. T., “Arc Chamber for Spectral Excitation in Controlled Atmospheres,” *Applied Spectroscopy*, APSPA, Vol 18, No. 6, 1964, pp. 189–191.
- (53) Sandell, E. B., *Colorimetric Determination of Traces of Metals*, New York, Interscience, 1950, p. 457.
- (54) Rodden, C. J., *Analytical Chemistry of the Manhattan Project*, New York, McGraw-Hill, 1950, pp. 450–457.
- (55) Vita, O. A., “The Colorimetric Determination of Molybdenum,” *Determination of Trace Elements in Uranium Compounds—Specification Analyses*, Goodyear Atomic Corp., Portsmouth, OH, 1968 (GAT-507).
- (56) Walker, C. R., and Vita, O. A., “Determination of Impurities in Uranium Compounds by Atomic Absorption,” *Analytica Chimica Acta*, 1968, Vol 43, p. 27.
- (57) Jursik, M. L., *Application of Atomic Absorption to Determination of Al, Fe, and Ni in the Same Uranium-Base Sample*, National Lead Company of Ohio, Cincinnati, OH, Sept. 19, 1966 (NLCO-987, CONF-661023-1).
- (58) Wright, W. B., Jr., *Critical Literature Survey of Tributylphosphate as a Uranium Extractant*, Union Carbide Corp., Nuclear Division, Y-12 Plant, Oak Ridge, TN, Jan. 14, 1952 (Y-838).
- (59) Humphrey, J. R., *Analytical Chemistry*, ANCHA, Vol 37, 1965, pp. 1604–5.
- (60) Graff, R. L. and Mullin, H. R., New Brunswick Laboratory, “The Analysis of Uranium Solution by Atomic Absorption Spectrometry,” presented at the 10th Conference on Analytical Chemistry in Nuclear Technology, Gatlinburg, TN, Sept. 27–29, 1966 (CONF-660933).
- (61) Tingey, F. H., Balkovetz, et al, *Qualification of Umpire Laboratories for the Analysis of Uranium and Plutonium Materials Specifications, Report III. First Report on Uranium Hexafluoride*, Idaho Nuclear Corp., Idaho Falls, ID, August 1969.
- (62) Kienberger, C. A., and Flynn, A. R., *A Simplified Analytical Method for Separating Traces of Fission Products from Uranium and Thorium (UX₁)*, Union Carbide Corp., Nuclear Division, Oak Ridge Gaseous Diffusion Plant, Oak Ridge, TN, Dec. 2, 1953 (K-1078).
- (63) Borkowski, C. J., *Analytical Chemistry*, ANCHA, Vol 21, 1949, p. 348.
- (64) *High Pressure Ionization Chamber*, Drawings D-AWM-8796A-2, D-AWM-8797-2, D-AWM-8798-2, D-AWM-8799-2, D-AWM16614-2, D-AWM-16615-2, Union Carbide Corp., Nuclear Division, Oak Ridge Gaseous Diffusion Plant, Oak Ridge, TN (CAPE 1238).
- (65) Flynn, A. R., *Measuring Fission Product Activity in Uranium Containing U²³² Daughters*, Union Carbide Corp., Nuclear Division, Oak Ridge Gaseous Diffusion Plant, Oak Ridge, TN, Dec. 12, 1968 (K-1757).
- (66) Vita, O. A., and Trivisonno, C. F., *The Microdetermination of Plutonium in Uranium Compounds*, Goodyear Atomic Corp., Portsmouth, OH, 1967 (GAT-T-1481).
- (67) Seaborg, Glenn T., and Katz, Joseph J., *The Actinide Elements*, National Nuclear Energy Series, Div. IV, Vol 14A, New York, McGraw-Hill, 1954.
- (68) Wish, L., and Rowell, M., *Sequential Analysis of Tracer Amounts of Np, U, and Pu in Fission-Product Mixtures by Anion Exchange*, U. S. Naval Radiological Defense Laboratory, San Francisco, CA, Oct. 11, 1956 (USNRDL-TR-117).
- (69) Anders, Edward, *The Radiochemistry of Technetium* (Nuclear Science Series NAS-NS 3021). Subcommittee on Radiochemistry, National Academy of Sciences—National Research Council, Washington, DC, 1960.
- (70) Federal Register, Vol 36, FR 11877–11878, June 22, 1971.
- (71) Floyd, M. A., Morrow, R. W., and Farrar, R. B., “Inductively Coupled Plasma-Atomic Emission Spectroscopy: The Determination of Trace Impurities in Uranium Hexafluoride.” *Spectrochimica Acta*. Vol 288. Nos. 1/2, pp. 303–308, 1983.
- (72) Short, B. W., Spring, H. S., Grant, R. I., *Determination of Trace Impurities in Uranium Hexafluoride by Inductively Coupled Argon Plasma Spectrometer*, GAT-T-3184, Goodyear Atomic Corporation, Portsmouth, OH, 1983.
- (73) Santoliquido, P. M., *Preparation and Provisional Certification of NBI Spectrographic Impurity Standards CRM No. 123 (1-7) and CRM No. 124 (1-8)*, NBL-310, U.S. Department of Energy, Chicago Operations Office New Brunswick Laboratory, Argonne, IL, 1983.
- (74) Muzik, R. J., and Vita, O. A., “Spectrographic Microdetermination of Refractory Elements in Uranium,” *Anal. Chimica Acta*. 1971. Vol 000, pp. 331–340.

ASTM International takes no position respecting the validity of any patent rights asserted in connection with any item mentioned in this standard. Users of this standard are expressly advised that determination of the validity of any such patent rights, and the risk of infringement of such rights, are entirely their own responsibility.

This standard is subject to revision at any time by the responsible technical committee and must be reviewed every five years and if not revised, either reapproved or withdrawn. Your comments are invited either for revision of this standard or for additional standards and should be addressed to ASTM International Headquarters. Your comments will receive careful consideration at a meeting of the responsible technical committee, which you may attend. If you feel that your comments have not received a fair hearing you should make your views known to the ASTM Committee on Standards, at the address shown below.

This standard is copyrighted by ASTM International, 100 Barr Harbor Drive, PO Box C700, West Conshohocken, PA 19428-2959, United States. Individual reprints (single or multiple copies) of this standard may be obtained by contacting ASTM at the above address or at 610-832-9585 (phone), 610-832-9555 (fax), or service@astm.org (e-mail); or through the ASTM website (www.astm.org).