



Standard Test Method for Flexural Strength of Concrete (Using Simple Beam with Third-Point Loading)¹

This standard is issued under the fixed designation C 78; the number immediately following the designation indicates the year of original adoption or, in the case of revision, the year of last revision. A number in parentheses indicates the year of last reapproval. A superscript epsilon (ϵ) indicates an editorial change since the last revision or reapproval.

This standard has been approved for use by agencies of the Department of Defense.

1. Scope*

1.1 This test method covers the determination of the flexural strength of concrete by the use of a simple beam with third-point loading.

1.2 The values stated in inch-pound units are to be regarded as the standard. The SI equivalent of inch-pound units has been rounded where necessary for practical application.

1.3 *This standard does not purport to address all of the safety concerns, if any, associated with its use. It is the responsibility of the user of this standard to establish appropriate safety and health practices and determine the applicability of regulatory limitations prior to use.*

2. Referenced Documents

2.1 ASTM Standards:²

C 31/C 31M Practice for Making and Curing Concrete Test Specimens in the Field

C 42/C 42M Test Method for Obtaining and Testing Drilled Cores and Sawed Beams of Concrete

C 192/C 192M Practice for Making and Curing Concrete Test Specimens in the Laboratory

C 617 Practice for Capping Cylindrical Concrete Specimens

C 1077 Practice for Laboratories Testing Concrete and Concrete Aggregates for Use in Construction and Criteria for Laboratory Evaluation

E 4 Practices for Force Verification of Testing Machines

3. Significance and Use

3.1 This test method is used to determine the flexural strength of specimens prepared and cured in accordance with Test Methods C 42/C 42M or Practices C 31/C 31M or C 192/

C 192M. Results are calculated and reported as the modulus of rupture. The strength determined will vary where there are differences in specimen size, preparation, moisture condition, curing, or where the beam has been molded or sawed to size.

3.2 The results of this test method may be used to determine compliance with specifications or as a basis for proportioning, mixing and placement operations. It is used in testing concrete for the construction of slabs and pavements.

4. Apparatus

4.1 The testing machine shall conform to the requirements of the sections on Basis of Verification, Corrections, and Time Interval Between Verifications of Practices E 4. Hand operated testing machines having pumps that do not provide a continuous loading in one stroke are not permitted. Motorized pumps or hand operated positive displacement pumps having sufficient volume in one continuous stroke to complete a test without requiring replenishment are permitted and shall be capable of applying loads at a uniform rate without shock or interruption.

4.2 *Loading Apparatus*—The third point loading method shall be used in making flexure tests of concrete employing bearing blocks which will ensure that forces applied to the beam will be perpendicular to the face of the specimen and applied without eccentricity. A diagram of an apparatus that accomplishes this purpose is shown in Fig. 1.

4.2.1 All apparatus for making flexure tests of concrete shall be capable of maintaining the specified span length and distances between load-applying blocks and support blocks constant within ± 0.05 in. (± 1.3 mm).

4.2.2 The ratio of the horizontal distance between the point of application of the load and the point of application of the nearest reaction to the depth of the beam shall be 1.0 ± 0.03 .

4.2.3 If an apparatus similar to that illustrated in Fig. 1 is used: the load-applying and support blocks should not be more than $2\frac{1}{2}$ in. (64 mm) high, measured from the center or the axis of pivot, and should extend entirely across or beyond the full width of the specimen. Each case-hardened bearing surface in contact with the specimen shall not depart from a plane by more than 0.002 in. (0.05 mm) and shall be a portion of a cylinder, the axis of which is coincidental with either the axis of the rod or center of the ball, whichever the block is pivoted

¹ This test method is under the jurisdiction of ASTM Committee C09 on Concrete and Concrete Aggregates and is the direct responsibility of Subcommittee C09.61 on Testing for Strength.

Current edition approved Feb. 1, 2008. Published February 2008. Originally approved in 1930. Last previous edition approved in 2007 as C 78 – 07.

² For referenced ASTM standards, visit the ASTM website, www.astm.org, or contact ASTM Customer Service at service@astm.org. For *Annual Book of ASTM Standards* volume information, refer to the standard's Document Summary page on the ASTM website.

*A Summary of Changes section appears at the end of this standard.

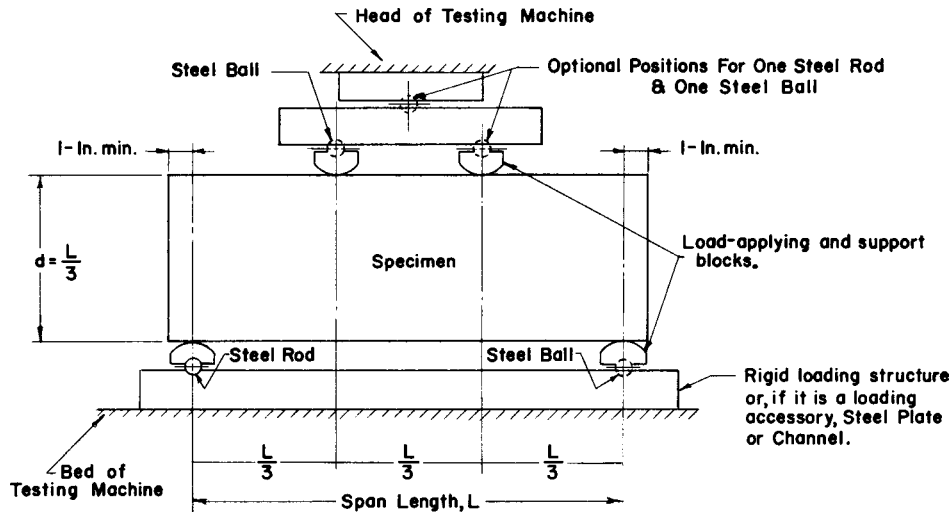

NOTE 1—This apparatus may be used inverted. If the testing machine applies force through a spherically seated head, the center pivot may be omitted, provided one load-applying block pivots on a rod and the other on a ball.

NOTE 2—1 in. = 25.4 mm.

FIG. 1 Diagrammatic View of a Suitable Apparatus for Flexure Test of Concrete by Third-Point Loading Method

upon. The angle subtended by the curved surface of each block should be at least 45° (0.79 rad). The load-applying and support blocks shall be maintained in a vertical position and in contact with the rod or ball by means of spring-loaded screws that hold them in contact with the pivot rod or ball. The uppermost bearing plate and center point ball in Fig. 1 may be omitted when a spherically seated bearing block is used, provided one rod and one ball are used as pivots for the upper load-applying blocks.

5. Testing

5.1 The test specimen shall conform to all requirements of Test Method C 42/C 42M or Practices C 31/C 31M or C 192/C 192M applicable to beam specimens and shall have a test span within 2 % of being three times its depth as tested. The sides of the specimen shall be at right angles with the top and bottom. All surfaces shall be smooth and free of scars, indentations, holes, or inscribed identification marks.

5.2 The individual who tests concrete beams for acceptance testing shall meet the concrete laboratory technician requirements of Practice C 1077 including Test Method C 78 as a relevant test.

6. Procedure

6.1 Flexural tests of moist-cured specimens shall be made as soon as practical after removal from moist storage. Surface drying of the specimen results in a reduction in the measured flexural strength.

6.2 When using molded specimens, turn the test specimen on its side with respect to its position as molded and center it on the support blocks. When using sawed specimens, position the specimen so that the tension face corresponds to the top or bottom of the specimen as cut from the parent material. Center the loading system in relation to the applied force. Bring the load-applying blocks in contact with the surface of the specimen at the third points and apply a load of between 3 and 6 %

of the estimated ultimate load. Using 0.004 in. (0.10 mm) and 0.015 in. (0.38 mm) leaf-type feeler gages, determine whether any gap between the specimen and the load-applying or support blocks is greater or less than each of the gages over a length of 1 in. (25 mm) or more. Grind, cap, or use leather shims on the specimen contact surface to eliminate any gap in excess of 0.004 in. (0.10 mm) in width. Leather shims shall be of uniform $\frac{1}{4}$ in. (6.4 mm) thickness, 1 to 2 in. (25 to 50 mm) width, and shall extend across the full width of the specimen. Gaps in excess of 0.015 in. (0.38 mm) shall be eliminated only by capping or grinding. Grinding of lateral surfaces should be minimized inasmuch as grinding may change the physical characteristics of the specimens. Capping shall be in accordance with the applicable sections of Practice C 617.

6.3 Load the specimen continuously and without shock. The load shall be applied at a constant rate to the breaking point. Apply the load at a rate that constantly increases the maximum stress on the tension face between 125 and 175 psi/min (0.86 and 1.21 MPa/min) until rupture occurs. The loading rate is calculated using the following equation:

$$r = Sbd^2/L \quad (1)$$

where:

r = loading rate, lb/min (N/min),

S = rate of increase in maximum stress on the tension face, psi/min (MPa/min),

b = average width of the specimen as oriented for testing, in. (mm),

d = average depth of the specimen as oriented for testing, in. (mm), and

L = span length, in (mm).

7. Measurement of Specimens After Test

7.1 To determine the dimensions of the specimen cross section for use in calculating modulus of rupture, take measurements across one of the fractured faces after testing. The

width and depth are measured with the specimen as oriented for testing. For each dimension, take one measurement at each edge and one at the center of the cross section. Use the three measurements for each direction to determine the average width and the average depth. Take all measurements to the nearest 0.05 in. (1 mm). If the fracture occurs at a capped section, include the cap thickness in the measurement.

8. Calculation

8.1 If the fracture initiates in the tension surface within the middle third of the span length, calculate the modulus of rupture as follows:

$$R = PL/bd^2 \quad (2)$$

where:

R = modulus of rupture, psi, or MPa,

P = maximum applied load indicated by the testing machine, lbf, or N,

L = span length, in., or mm,

b = average width of specimen, in., or mm, at the fracture, and

d = average depth of specimen, in., or mm, at the fracture.

NOTE 1—The weight of the beam is not included in the above calculation.

8.2 If the fracture occurs in the tension surface outside of the middle third of the span length by not more than 5 % of the span length, calculate the modulus of rupture as follows:

$$R = 3Pa/bd^2 \quad (3)$$

where:

a = average distance between line of fracture and the nearest support measured on the tension surface of the beam, in., (or mm).

NOTE 2—The weight of the beam is not included in the above calculation.

8.3 If the fracture occurs in the tension surface outside of the middle third of the span length by more than 5 % of the span length, discard the results of the test.

9. Report

9.1 Report the following information:

9.1.1 Identification number,

9.1.2 Average width to the nearest 0.05 in. (1 mm),

9.1.3 Average depth to the nearest 0.05 in. (1 mm),

9.1.4 Span length in inches (or millimeters),

9.1.5 Maximum applied load in pound-force (or newtons),

9.1.6 Modulus of rupture calculated to the nearest 5 psi (0.05 MPa),

9.1.7 Curing history and apparent moisture condition of the specimens at the time of test,

9.1.8 If specimens were capped, ground, or if leather shims were used,

9.1.9 Whether sawed or molded and defects in specimens, and

9.1.10 Age of specimens.

10. Precision and Bias

10.1 *Precision*—The coefficient of variation of test results has been observed to be dependent on the strength level of the beams.³ The single operator coefficient of variation has been found to be 5.7 %. Therefore, results of two properly conducted tests by the same operator on beams made from the same batch sample should not differ from each other by more than 16 %. The multilaboratory coefficient of variation has been found to be 7.0 %. Therefore, results of two different laboratories on beams made from the same batch sample should not differ from each other by more than 19 %.

10.2 *Bias*—Since there is no accepted standard for determining bias in this test method, no statement on bias is made.

11. Keywords

11.1 beams; concrete; flexural strength testing; modulus of rupture

³ See "Improved Concrete Quality Control Procedures Using Third Point Loading" by P. M. Carrasquillo and R. L. Carrasquillo, Research Report 119-1F, Project 3-9-87-1119, Center For Transportation Research, The University of Texas at Austin, November 1987, for possible guidance as to the relationship of strength and variability.

SUMMARY OF CHANGES

Committee C09 has identified the location of selected changes to this test method since the last issue, C 78 – 07, that may impact the use of this test method. (Approved February 1, 2008)

(1) Revised 5.2 and deleted Note 1.

Committee C09 has identified the location of selected changes to this test method since the last issue, C 78 – 02, that may impact the use of this test method. (Approved August 15, 2007)

(1) Revised 5.1.

(2) Revised 6.3.

(3) Revised 7.1.

ASTM International takes no position respecting the validity of any patent rights asserted in connection with any item mentioned in this standard. Users of this standard are expressly advised that determination of the validity of any such patent rights, and the risk of infringement of such rights, are entirely their own responsibility.

This standard is subject to revision at any time by the responsible technical committee and must be reviewed every five years and if not revised, either reapproved or withdrawn. Your comments are invited either for revision of this standard or for additional standards and should be addressed to ASTM International Headquarters. Your comments will receive careful consideration at a meeting of the responsible technical committee, which you may attend. If you feel that your comments have not received a fair hearing you should make your views known to the ASTM Committee on Standards, at the address shown below.

This standard is copyrighted by ASTM International, 100 Barr Harbor Drive, PO Box C700, West Conshohocken, PA 19428-2959, United States. Individual reprints (single or multiple copies) of this standard may be obtained by contacting ASTM at the above address or at 610-832-9585 (phone), 610-832-9555 (fax), or service@astm.org (e-mail); or through the ASTM website (www.astm.org).