



Standard Test Method of Measuring Thermal Expansion and Creep of Refractories Under Load¹

This standard is issued under the fixed designation C 832; the number immediately following the designation indicates the year of original adoption or, in the case of revision, the year of last revision. A number in parentheses indicates the year of last reapproval. A superscript epsilon (ϵ) indicates an editorial change since the last revision or reapproval.

1. Scope

1.1 This test method covers the procedure for measuring the linear change of refractory specimens that are subjected to compressive stress while being heated and while being held at elevated temperatures.

1.2 This test method does not apply to materials whose strength depends on pitch or carbonaceous bonds unless appropriate atmospheric control is used (see 7.3).

1.3 The values stated in inch-pound units are to be regarded as standard. The values given in parentheses are mathematical conversions to SI units that are provided for information only and are not considered standard.

1.4 *This standard does not purport to address all of the safety concerns, if any, associated with its use. It is the responsibility of the user of this standard to establish appropriate safety and health practices and determine the applicability of regulatory limitations prior to use.*

2. Referenced Documents

2.1 *ASTM Standards:*²

E 691 Practice for Conducting an Interlaboratory Study to Determine the Precision of a Test Method

3. Terminology

3.1 *Definitions of Terms Specific to This Standard:*

3.1.1 *maximum dilation*—the percent expansion where the thermal-expansion rate equals the creep-deformation rate. It can be used in estimating thermal-expansion relief when used in conjunction with the temperature at maximum dilation.

3.1.2 *temperature at maximum dilation*—in addition to estimating thermal-expansion relief, it can be used to rank products in terms of relative refractoriness. In general, the higher the temperature at maximum dilation, the more refractory the product and the better it is able to resist deformation at elevated temperatures.

¹ This test method is under the jurisdiction of ASTM Committee C08 on Refractories and is the direct responsibility of Subcommittee C08.01 on Strength. Current edition approved Dec. 1, 2005. Published December 2005. Originally approved in 1976. Last previous edition approved in 2000 as C 832 – 00.

² For referenced ASTM standards, visit the ASTM website, www.astm.org, or contact ASTM Customer Service at service@astm.org. For *Annual Book of ASTM Standards* volume information, refer to the standard's Document Summary page on the ASTM website.

3.1.3 *20 to 50 h creep*—the percent deformation between the 20 and 50 h can be used to rank products in terms of relative load bearing capacity at a particular temperature. Relative rankings of various products may differ at different temperatures.

4. Summary of Test Method

4.1 Test specimens sawed from samples of refractory brick or from prefabricated samples of monolithic refractories are placed in a furnace and subjected to a prescribed compressive stress. Sensors are positioned for continuously measuring the linear change of the specimens parallel to the direction of the compressive stress. The temperature and linear change of the specimens are continuously recorded while heating the furnace at a controlled rate for thermal expansion under load testing. The time and linear change of the specimens are also continuously recorded while at soak temperature for 20 to 50 h of creep testing.

4.2 The user should be aware that other mechanisms, besides those related to creep, may be activated. This is especially true as temperatures approach 1650°C. When other material responses are activated, such as corrosion, oxidation, sintering, etc., strong caution should be exercised when interpreting and identifying creep mechanisms.

4.3 Since materials tend to exhibit faster creep rates during the initial stage of deformation, the user should be cautioned when extrapolating measured creep rates beyond the normal 50 h test time. The material must be in the secondary creep stage in order to extrapolate to longer times.

5. Significance and Use

5.1 The thermal expansion under load and the 20 to 50 h creep properties of a refractory are useful in characterizing the load bearing capacity of a refractory that is uniformly heated. Directly applicable examples are blast furnace stoves and glass furnace checkers.

6. Interferences

6.1 *Chemical Interactions with Test Environment*—The test environment (vacuum, inert gas, ambient air, etc.), including moisture content (percent relative humidity), may have a strong influence on both creep strain rate and creep rupture life. In particular, refractories susceptible to slow crack growth or

oxidation will be strongly influenced by the test environment. Testing should be conducted in environments that are either representative of service conditions or inert to the refractories being tested depending on the performance being evaluated.

6.2 *Specimen Surface Preparation*—Surface preparation of specimens can introduce machining flaws that may affect the creep strain rate and creep rupture life. Machining damage imposed during specimen preparation will most likely result in premature failure of the specimen, but may also introduce flaws that can grow by slow crack growth. Surface preparation can also lead to residual stresses, which can be released during the test.

6.3 *Specimen/Extensometer Chemical Interactions*—If the strain measurement technique relies on physical contact between the extensometer components (contacting probes or optical method flags) and the specimen, then the flag attachment methods and extensometer contact materials must be chosen with care to ensure that no adverse chemical reactions occur during testing. This should not be a problem if the probe or specimen materials are mutually chemically inert. The user should also be aware that impurities or second phases in the probes and flags or specimens may be mutually chemically reactive and could influence the results.

6.4 *Temperature Variations*—Creep strain is related to temperature through an exponential function. Thus, fluctuations in test temperature or changes in temperature profile along the length of the specimen can cause fluctuations in strain measurements or changes in creep rate (see 7.1 and 7.2).

7. Apparatus

7.1 *Electrically Heated Furnace*, with a setting space sufficient to contain one or more specimens of the size specified in Section 8. The specimens should be equally heated on at least two opposite sides, and the temperature difference between

specimens in a multiple-position furnace and between the top and bottom ends of single specimens should be no more than 18°F (10°C). See Figs. 1-5 for sketches of five typical furnace arrangements.

7.2 *Temperature Controllers*, that control heating at a rate of $100 \pm 9^\circ\text{F/h}$ ($55 \pm 5^\circ\text{C/h}$) over the temperature range from 500 to 3000°F (260 to 1650°C) and can control soak temperatures within $\pm 9^\circ\text{F}$ ($\pm 5^\circ\text{C}$).

7.3 *Air Atmosphere*, unless otherwise specified. If pitch or carbonaceous-bonded materials are tested, specify the atmosphere used when reporting results.

7.4 *Linear Measuring Device*, that records the difference in length dimension of each specimen parallel to the direction of stress and yields the desired precision and reproducibility.

7.5 *Recorders*, that display linear change readings to ± 0.0005 in. (0.013 mm).

7.6 *Loading Devices*, that apply at least 100 psi (689 kPa) compressive stress within $\pm 1\%$, on a 1½ by 1½-in. (38 by 38-mm) cross section.

8. Specimen Preparation

8.1 Cut or form specimens nominally 1½ by 1½ by 4½ in. (38 by 38 by 114 mm) (Note 1) with the 4½-in. dimension perpendicular to the pressing direction of a brick, the ramming direction of a plastic, or the position of the vibrator used in forming a castable. The 4½-in. dimension may be parallel to the length or width of the original shape.

NOTE 1—Specimens of different geometry (for example, cylindrical) may be used upon agreement between the parties concerned.

8.2 Grind or sand both 1½ by 1½-in. (38 by 38-mm) surfaces so that they are nominally plane and perpendicular to the length dimension. The parallelness tolerance on the loading surfaces of the specimen is recommended to be within 0.001 in.

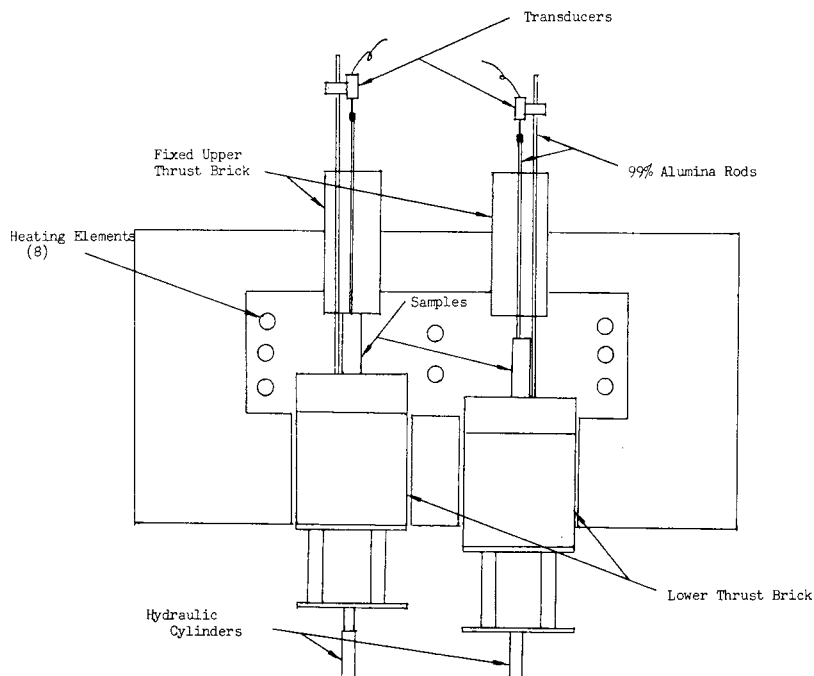

FIG. 1 Specimen Furnace Arrangement

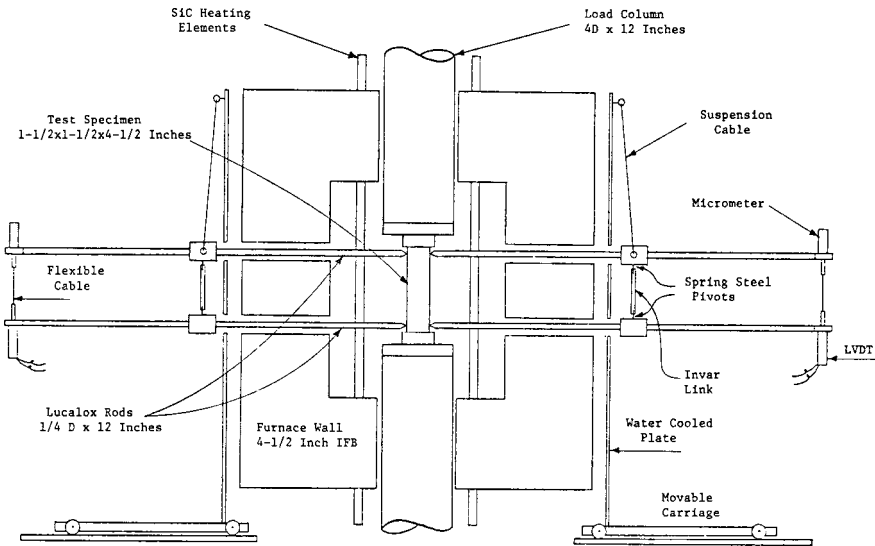

FIG. 2 Specimen Furnace Arrangement

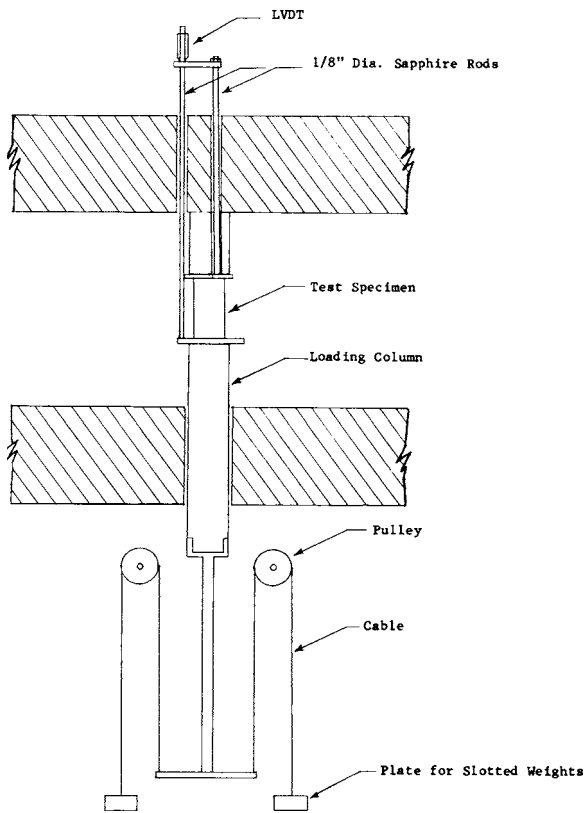

FIG. 3 Specimen Furnace Arrangement

(0.03 mm). Only the 1½ by 1½-in. (38 by 38-mm) and one 1½ by 4½-in. (38 by 114-mm) surfaces may be original.

8.3 Measure all dimensions to the nearest 0.001 in. (0.03 mm) as follows:

8.3.1 *Length*—Average five measurements which include four taken at ¼ in. (6 mm) on the diagonal from each corner and one at the center of the faces.

8.3.2 *Width and Depth*—Average three measurements which include one taken at the center of the faces and two from the quarter points.

8.3.3 Calculate the cross-sectional area of each specimen and use to determine the precise loading per specimen.

9. Calibration

9.1 Calibrate each loading and measuring position separately. Follow the procedure given in Section 10 and determine the “machine output” curves for each position using a specimen of known thermal expansion. Calibration shall be done on each new furnace and after replacement of any parts of the measuring or loading devices. Fused magnesium oxide (MgO) or isostatically pressed and fired MgO of 99 % minimum purity and 3.18 g/cm³ minimum bulk density is recommended for standardization. Volume stable 90 % plus aluminum oxide (Al₂O₃), fused silica (SiO₂), or sapphire may also be used if reliable thermal expansion data are available. Make these runs with the loading mechanism blocked so that the specimen is essentially under zero stress.

9.2 Make a minimum of three runs and record the measurements of linear change continuously with a computer/data acquisition system or on a strip chart or X-Y recorder or, if done manually, at 100°F (55°C) intervals up to 2000°F (1095°C) and 50°F (28°C) intervals above 2000°F while heating in accordance with 10.5. Reposition the specimen after each run to ensure that all random errors due to handling are repeated each time. To ensure that the error for these runs is no greater than ±0.05 % expansion at a probability level of 0.95, the standard deviation of the machine output cannot exceed 0.02 percentage points.

9.3 If MgO is chosen as the calibration standard, use the expansion data listed for MgO in Table 1.

9.4 Obtain correction factors at the selected temperature levels from the algebraic difference between the average machine output in percent and the applicable true-expansion percentage for the calibration standard. The algebraic sum of

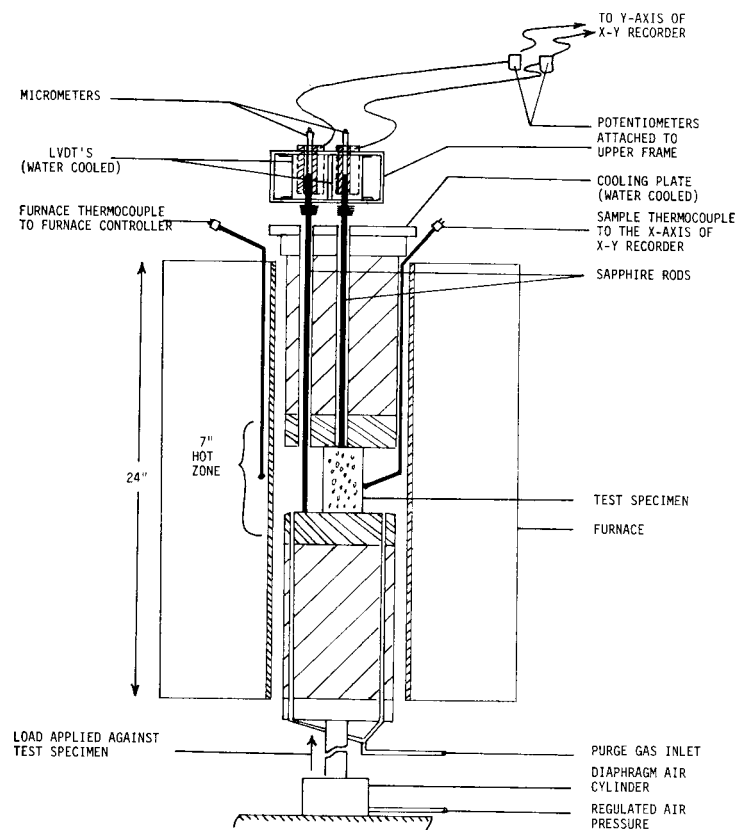

FIG. 4 Specimen Furnace Arrangement

the correction factors and the machine output of an unknown yields the expansion data in percent for the unknown.

10. Procedure

10.1 After leveling the hearth setters, place each specimen in the furnace with its longitudinal axis in alignment with the centerline of the loading device. To protect the bottom of the load plunger, place a 1/4-in. (6-mm) thick slab of alumina or silicon carbide on top of the specimen. A slab works best if it is larger than the specimen, such as one that is approximately equal in length and width to the cross section of the plunger. If chemical reaction between specimen and furnace loading parts is expected, use a piece of 1-mil (25.4- μ m) thick platinum foil between the top and bottom of the specimen and the furnace parts (Note 2). Do not use setting powder. The top of each specimen shall be level and parallel to the bottom setter.

NOTE 2—As testing temperatures approach 1650°C, spacers of Al₂O₃, SiC, or Pt may not be suitable due to chemical reaction with the specimen or creep of the spacer. Under these conditions, the measured dilation may be significantly affected.

10.2 Position linear measuring devices and check for freedom of movement of sensor rods, dials, plungers, linearly variable differential transformers (LVDTs), and operation of recording equipment.

10.3 Apply loads on each specimen in the amount necessary to provide the desired stress as determined by the specimen cross-sectional area. The stress level used must accompany test results. Use a stress of 25 psi (172 kPa) unless otherwise

specified. Stress levels other than 25 psi (172 kPa) may be used upon agreement between the interested parties.

10.4 Use a calibrated thermocouple, preferably connected to a program controller, for measuring and controlling furnace temperature. For accuracy in measuring specimen temperature, it is recommended that a grounded, insulated, and calibrated thermocouple be placed so that the hot junction is within 1/2 in. (6 mm) of the midpoint of every specimen (Note 3).

NOTE 3—Control of the temperature is essential for accurate results. It is recommended that access ports be provided to periodically check the temperature of each specimen with a calibrated thermocouple to ensure that the desired temperature is obtained throughout the test.

10.5 Heating control may be manual, but an electrically driven program controller is preferred. Heat the furnace at a rate of 100 \pm 9°F/h (55 \pm 5°C/h) to the desired soak temperature.

10.6 For thermal expansion under load testing, continuously record the measurements of linear change with a computer/data acquisition system or on a strip chart or X-Y recorder, or manually at intervals of 100°F (55°C) during heating. At temperatures above 2000°F (1095°C), take readings at 50°F (28°C) intervals.

10.7 Continue heating until one of the following occurs:

10.7.1 Linear thermal expansion ceases, and a maximum dilation level is identifiable, and 20 to 50 h creep testing is not desired, or

10.7.2 The specimen fails.

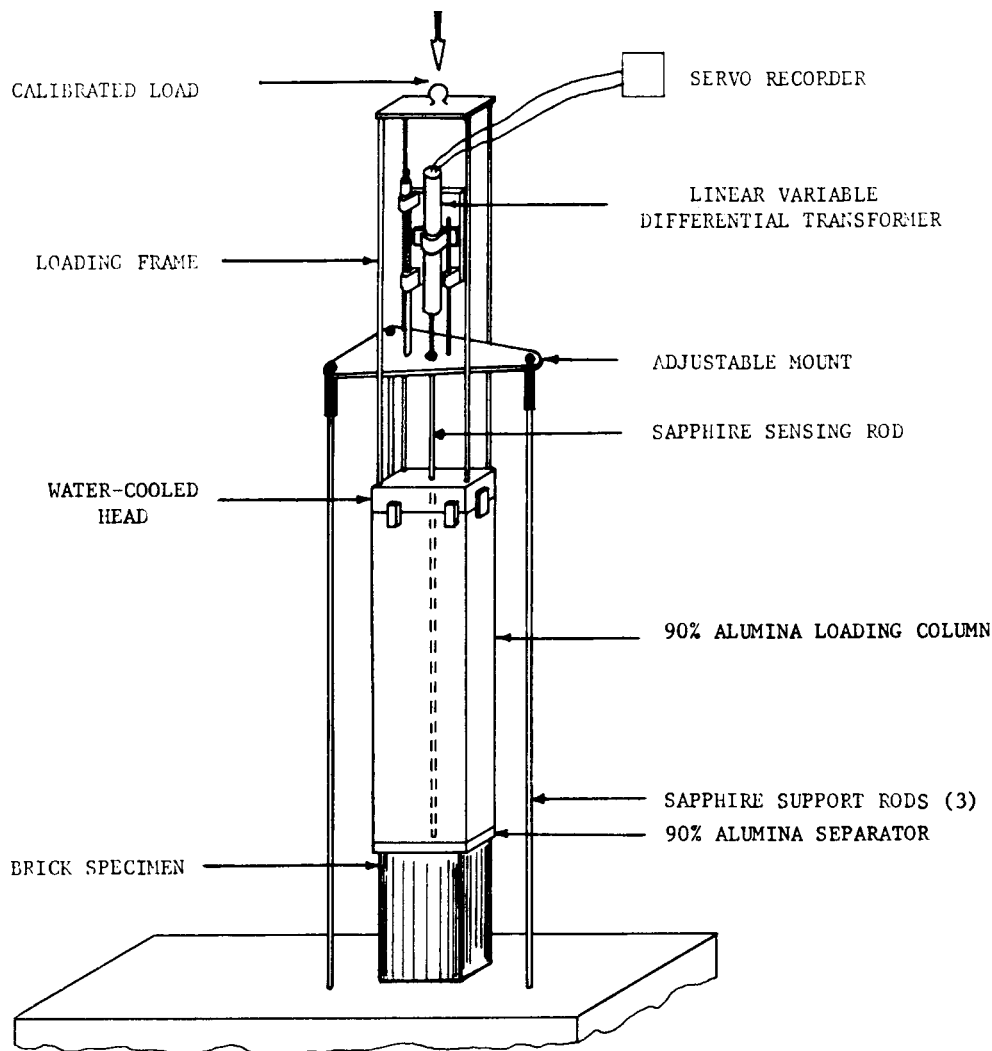

NOTE—This apparatus has been developed and patented by Bethlehem Steel Corporation as U.S. Patent No. 3.234.778. A free nonexclusive license to make, have made, and use this apparatus will be granted on request.

FIG. 5 Specimen Furnace Arrangement

10.8 For 20 to 50-h creep testing, hold the specimen at the desired soak temperature for 50 h. Continuously record the measurement of linear change with a computer/data acquisition system or on a strip chart or X-Y recorder, or manually at intervals of 5 h.

10.9 Convert linear measurements to percent and record to the nearest 0.001 %. Test at least two specimens. Each specimen is considered a test result and replicates must be tested in the same furnace.

11. Report

11.1 For the thermal expansion under load test, report the average and standard deviation for the temperature and linear change at the maximum level of expansion where the creep rate equals the expansion rate. This point is called the maximum dilation point. Report temperature to the nearest 9°F (5°C) and expansion to the nearest 0.001 %. Base results on at least two specimens.

11.2 For the 20 to 50 h creep test, report the average and standard deviation for the creep between 20 and 50 h. Base results on at least two specimens.

12. Precision and Bias

12.1 *Interlaboratory Data*—An interlaboratory round robin was conducted in 1983 in which four laboratories each tested two specimens from five different types of refractory materials. Each laboratory determined the maximum dilation as percent expansion, temperature of maximum dilation, and the 20 to 50 h creep percent. Each laboratory tested each specimen at a 28.6 psi (2 kg/cm² or 197 kPa) load. The components of variance from this study expressed as standard deviation and relative standard deviation are given in Table 2. Refer to Practice E 691 for calculation of components of variance.

12.2 *Precision*—On the basis of the components of variance given in Table 2, the precision and relative precision of each material at the 95 % probability level are given in Table 3 for all three properties.

TABLE 1 Thermal Expansion Data for MgO Standard

Mean Temperature		Linear Expansion, %
°F	°C	
200	95	0.06
300	150	0.13
400	205	0.20
500	260	0.27
600	315	0.35
700	370	0.43
800	425	0.51
900	480	0.58
1000	540	0.66
1100	595	0.74
1200	650	0.82
1300	705	0.91
1400	760	0.99
1500	815	1.07
1600	870	1.16
1700	925	1.24
1800	980	1.33
1900	1040	1.41
2000	1095	1.50
2100	1150	1.59
2200	1205	1.67
2300	1260	1.76
2400	1315	1.85
2500	1370	1.93
2600	1425	2.01

TABLE 2 Round-Robin Test Results^A

Brick Type	Test Temperature, °C	Average, \bar{X}	Standard Deviation		Relative Standard Deviation	
			S_r	S_R	% V_r	% V_R
<i>20 to 50 h Creep at 28.6 psi (197 kPa):</i>						
Super duty	1250	0.068	0.0160	0.019	23.6	27.9
60 % alumina	1350	0.189	0.0187	0.059	9.9	31.2
90 % magnesia	1350	0.713	0.0867	0.235	12.2	33.0
Silica	1500	0.124	0.0236	0.039	19.1	31.5
98 % magnesia	1500	0.064	0.0103	0.012	16.3	18.8
<i>Maximum Dilation—% Expansion:</i>						
Super duty	1250	0.633	0.054	0.067	8.5	10.6
60 % alumina	1350	0.625	0.078	0.081	12.5	13.0
90 % magnesia	1350	1.733	0.099	0.260	5.7	15.0
Silica	1500	1.215	0.103	0.103	8.4	8.5
98 % magnesia	1500	2.043	0.184	0.256	9.0	12.5
<i>Maximum Dilation—Temperature, °C:</i>						
Super duty	1250	1205	20.2	59.1	1.7	4.9
60 % alumina	1350	1292	35.6	35.6	2.8	2.8
90 % magnesia	1350					
Silica	1500	900.5	48.9	114.2	5.4	12.7
98 % magnesia	1500					

^A Refer to Practice E 691 for calculation of components of variance.

12.3 *Bias*—No justifiable statement of bias can be made since the true values for the maximum dilation point and 20 to 50 h creep of different refractories cannot be established by an accepted reference method.

13. Keywords

13.1 compressive stress; creep; elevated temperatures; linear change; refractories; thermal dilation; thermal expansion



TABLE 3 Precision Data

Brick Type	Precision		Relative Precision	
	Repeat- ability, <i>r</i>	Repro- ducibility, <i>R</i>	% <i>r</i>	% <i>R</i>
<i>20 to 50 h Creep:</i>				
Super Duty	0.045	0.054	66.8	78.9
60 % alumina	0.053	0.167	27.9	88.6
90 % magnesia	0.245	0.666	34.4	93.3
Silica	0.067	0.111	54.1	90.0
98 % magnesia	0.029	0.035	46.0	54.9
<i>Maximum Dilation—% Expansion:</i>				
Super Duty	0.152	0.191	24.0	30.2
60 % alumina	0.221	0.228	35.4	36.5
90 % magnesia	0.279	0.735	16.1	42.4
Silica	0.290	0.290	23.9	23.9
98 % magnesia	0.520	0.725	25.5	35.5
<i>Maximum Dilation—Temperature:</i>				
Super Duty	57.0	167.2	4.7	13.9
60 % alumina	100.8	100.8	7.8	7.8
90 % magnesia				
Silica	138.5	322.9	15.4	35.9
98 % magnesia ^A

^A 90 and 98 % magnesia maximum temperature = test temperature.

ASTM International takes no position respecting the validity of any patent rights asserted in connection with any item mentioned in this standard. Users of this standard are expressly advised that determination of the validity of any such patent rights, and the risk of infringement of such rights, are entirely their own responsibility.

This standard is subject to revision at any time by the responsible technical committee and must be reviewed every five years and if not revised, either reapproved or withdrawn. Your comments are invited either for revision of this standard or for additional standards and should be addressed to ASTM International Headquarters. Your comments will receive careful consideration at a meeting of the responsible technical committee, which you may attend. If you feel that your comments have not received a fair hearing you should make your views known to the ASTM Committee on Standards, at the address shown below.

This standard is copyrighted by ASTM International, 100 Barr Harbor Drive, PO Box C700, West Conshohocken, PA 19428-2959, United States. Individual reprints (single or multiple copies) of this standard may be obtained by contacting ASTM at the above address or at 610-832-9585 (phone), 610-832-9555 (fax), or service@astm.org (e-mail); or through the ASTM website (www.astm.org).