



# Standard Practice for Proportioning Grout Mixtures for Preplaced-Aggregate Concrete<sup>1</sup>

This standard is issued under the fixed designation C 938; the number immediately following the designation indicates the year of original adoption or, in the case of revision, the year of last revision. A number in parentheses indicates the year of last reapproval. A superscript epsilon ( $\epsilon$ ) indicates an editorial change since the last revision or reapproval.

*This standard has been approved for use by agencies of the Department of Defense.*

## 1. Scope

1.1 This practice describes the laboratory procedure for selecting proportions for grout mixtures required in the production of preplaced-aggregate (PA) concrete.

1.2 The values stated in SI units are to be regarded as the standard. The values given in parentheses are provided for information purposes only.

1.3 *This standard does not purport to address all of the safety concerns, if any, associated with its use. It is the responsibility of the user of this standard to establish appropriate safety and health practices and determine the applicability of regulatory limitations prior to use.*

## 2. Referenced Documents

### 2.1 ASTM Standards:

C 39/C 39M Test Method for Compressive Strength of Cylindrical Concrete Specimens<sup>2</sup>

C 109/C 109M Test Method for Compressive Strength of Hydraulic Cement Mortars (Using 2-in. or [50-mm] Cube Specimens)<sup>3</sup>

C 150 Specification for Portland Cement<sup>3</sup>

C 185 Test Method for Air Content of Hydraulic Cement Mortar<sup>3</sup>

C 192/C 192M Practice for Making and Curing Concrete Test Specimens in the Laboratory<sup>2</sup>

C 618 Specification for Coal Fly Ash and Raw or Calcined Natural Pozzolan for Use in Concrete<sup>2</sup>

C 637 Specification for Aggregates for Radiation-Shielding Concrete<sup>2</sup>

C 937 Specification for Grout Fluidifier for Preplaced-Aggregate Concrete<sup>2</sup>

C 939 Test Method for Flow of Grout for Preplaced-Aggregate Concrete (Flow-Cone Method)<sup>2</sup>

C 940 Test Method for Expansion and Bleeding of Freshly Mixed Grouts for Preplaced-Aggregate Concrete in the Laboratory<sup>2</sup>

C 941 Test Method for Water Retentivity of Grout Mixtures for Preplaced-Aggregate Concrete in the Laboratory<sup>2</sup>

C 942 Test Method for Compressive Strength of Grouts for Preplaced-Aggregate Concrete in the Laboratory<sup>2</sup>

C 943 Practice for Making Test Cylinders and Prisms for Determining Strength and Density of Preplaced-Aggregate Concrete in the Laboratory<sup>2</sup>

## 3. Summary of Practice

3.1 Grouts at fluid consistency are prepared from one or more mixtures of cement, pozzolan, fine aggregate, grout fluidifier, with or without other chemical admixtures, and water, and tested to determine:

3.1.1 The properties of the grout, and

3.1.2 The properties of PA concrete made with the grout when the grout is intended for such use.

3.2 The procedure and equipment required for mixing this grout are prescribed in this practice.

## 4. Significance and Use

4.1 This practice provides a standard procedure for selecting proportions for mixtures of grout to be used at fluid consistency in the production of PA concrete meeting applicable criteria for strength, density, and other properties.

4.2 This practice is also useful for determining the composition of grout mixed at fluid consistency and meeting specified requirements for filling voids, cavities, and spaces in rock, foundations, and concrete structures.

## 5. Apparatus

5.1 *Mixer*, constructed as shown in Fig. 1. The three mixer blades shall be made of steel plate, 3-mm (1/8-in.) thick, with a 100 by 125-mm (4 by 5-in.) elliptical shape. Each blade shall have two 25 by 75-mm (1 by 3-in.) slots centered on the major axis, and shall be welded to the shaft at an angle of approximately 23° with the horizontal in such a way as to force grout

<sup>1</sup> This practice is under the jurisdiction of ASTM Committee C09 on Concrete and Concrete Aggregates and is the direct responsibility of Subcommittee C09.41 on Concrete for Radiation Shielding.

Current edition approved Dec. 10, 2002. Published February 2003. Originally approved in 1982. Last previous edition approved in 1997 as C 938-97.

<sup>2</sup> *Annual Book of ASTM Standards*, Vol 04.02.

<sup>3</sup> *Annual Book of ASTM Standards*, Vol 04.01.

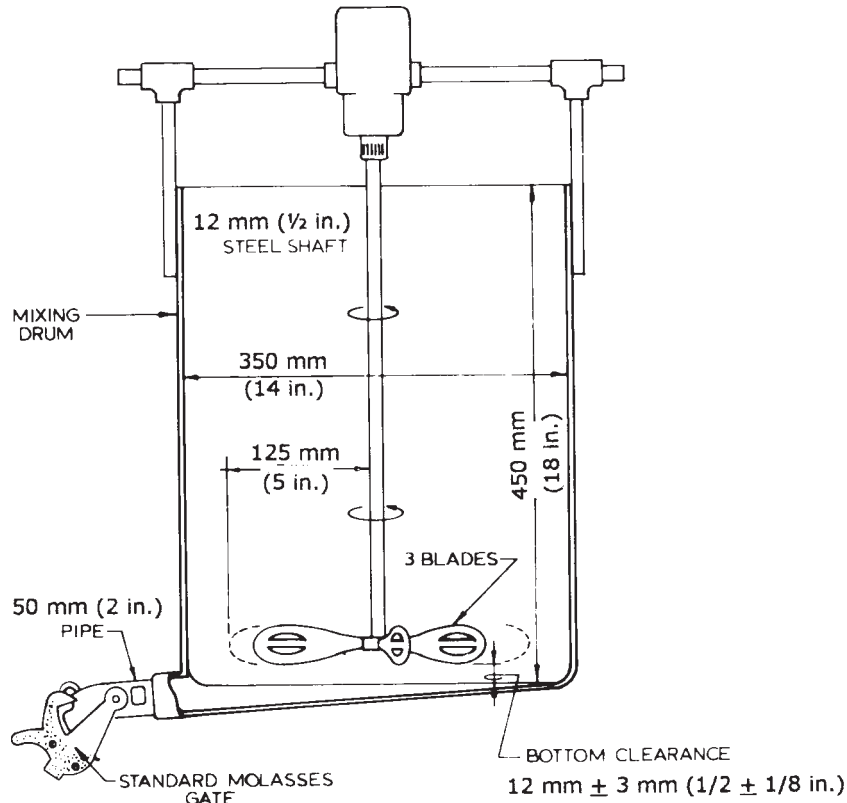

FIG. 1 Grout Mixer

to the bottom of the mixer during rotation. The mixer blades shall be powered to rotate at approximately 275 r/min under load.

5.2 *Scales or Balance*, accurate to within 0.3 % of the test mass at any point within range of use.

## 6. Materials

6.1 Materials for test purposes, except mixing water, shall meet the following requirements unless otherwise specified in project documents:

6.1.1 Portland cement, Specification C 150, nonair-entraining,

6.1.2 Pozzolan, if used, Specification C 618,

6.1.3 Fluidifier, Specification C 937, and

6.1.4 Fine aggregate, Specification C 637, Table number 2, Grading 1 for specific gravity under 3.0 and Grading 2 for specific activity 3.0 or heavier.

6.2 Where grout is being proportioned for use on a specific project, materials for test purposes shall be from and representative of the same source or type and description as will be used or is being considered for use on the project.

6.3 *Mixing water*, if clean and potable, is acceptable for normal test purposes.

## 7. Sampling

7.1 Samples of mixed grout for testing shall be representative of the batch from which they are drawn.

7.2 Agitation of the batch shall be continuous until all samples required from that batch have been drawn.

7.3 Grout in the mixer shall not be retempered by the addition of water. If mixing water is added in increments to adjust fluidity, a new batch shall be prepared for testing.

7.4 Samples shall be drawn for testing in the following order: (1) consistency, (2) expansion and bleeding, and (3), other requirements.

## 8. Conditioning

8.1 Maintain laboratory at and bring all grout materials to  $23.0 \pm 2.0^\circ\text{C}$  ( $73.5 \pm 3.5^\circ\text{F}$ ) unless otherwise specified.

## 9. Procedure

9.1 Prebatch grout ingredients by mass to provide a batch volume after mixing of approximately  $0.03 \text{ m}^3$  ( $1 \text{ ft}^3$ ).

9.2 The first trial mixture, unless otherwise specified, shall contain equal parts, by mass, of cementitious material and fine aggregate, fluidifier in amount 1 % mass of cementitious material, unless otherwise recommended by manufacturer, and sufficient water to produce a flow of  $21 \pm 2 \text{ s}$ . The cementitious material shall consist of two parts of portland cement to one part of pozzolan by mass.

9.3 In subsequent trial mixtures, the proportions of materials shall be varied as needed to satisfy design criteria. Adjusted mixtures may contain a cementitious ratio of portland cement to pozzolan other than as stipulated for the first trial mixture.

9.4 Dampen the inside of the mixer drum, turn the mixer on and charge the ingredients within 2 min in the following order: (1) water, (2) fluidifier, (3) pozzolan (if used), (4) portland

cement, and (5) fine aggregate. After all materials have been added, mix for 3 to 3¼ min.

9.5 Determine the following fluid grout properties in the order shown of each trial mixture:

Property	Test Method
Flow (time of efflux)	C 939
Expansion and bleeding	C 940
Water retentivity	C 941, if required
Unit mass	see 9.5.1
Other	as required

9.5.1 Determine the unit mass of the fluid grout using the measure described in the Apparatus section under “Measure” in Test Method C 185. Pour the grout into a container, tap the side lightly five times with a tapping stick as described in Test Method C 185, strike off, then measure mass.

9.6 Determine the following hardened grout and PA concrete properties:

Property	Test Method
Compressive strength of grout	C 942
Compressive strength of PA concrete	C 943, if required
Unit mass of grout	see 9.6.1
Unit mass of PA concrete	see 9.6.1, if required

9.6.1 To determine the unit mass of grout or PA concrete, measure mass of the specimen to an accuracy of at least one part in 250. Divide the masses by volumes determined as follows:

9.6.1.1 *Cubes*—Take two measurements of each dimension to nearest 0.25 mm (0.01 in.). Compute the volume from average measurements.

9.6.1.2 *PA Cylinders*—Take measurements of two diameters at right angles at approximate mid-height. Measure the length of the cylinder at opposite ends of a diameter. Make all measurements to nearest 0.25 mm (0.01 in.). Compute the volume from average measurements.

## 10. Report

10.1 For each mixture, including the final mixture, the following shall be reported:

10.1.1 A description of all materials used including type and alkali content of portland cement, type of pozzolan, source and name of fluidifier, and sieve analysis and specific gravity of fine and coarse aggregate.

10.2 For each trial mixture the following fluid grout properties shall be reported: (1) time of efflux, (2) expansion and free water, (3) water retentivity (if required), (4) and other specified data.

10.3 For final mixture(s) selected, the report shall include compressive strength of grout at ages of 7, 28, and 90 days, and unit mass unless otherwise required.

10.4 For PA concrete cylinders, the report shall include compressive strengths at ages of 7, 28, and 90 days, and unit mass unless otherwise required.

## 11. Keywords

11.1 concrete; grouts; pre-placed aggregate

*ASTM International takes no position respecting the validity of any patent rights asserted in connection with any item mentioned in this standard. Users of this standard are expressly advised that determination of the validity of any such patent rights, and the risk of infringement of such rights, are entirely their own responsibility.*

*This standard is subject to revision at any time by the responsible technical committee and must be reviewed every five years and if not revised, either reapproved or withdrawn. Your comments are invited either for revision of this standard or for additional standards and should be addressed to ASTM International Headquarters. Your comments will receive careful consideration at a meeting of the responsible technical committee, which you may attend. If you feel that your comments have not received a fair hearing you should make your views known to the ASTM Committee on Standards, at the address shown below.*

*This standard is copyrighted by ASTM International, 100 Barr Harbor Drive, PO Box C700, West Conshohocken, PA 19428-2959, United States. Individual reprints (single or multiple copies) of this standard may be obtained by contacting ASTM at the above address or at 610-832-9585 (phone), 610-832-9555 (fax), or service@astm.org (e-mail); or through the ASTM website (www.astm.org).*