



Standard Practice for Making Test Cylinders and Prisms for Determining Strength and Density of Preplaced-Aggregate Concrete in the Laboratory¹

This standard is issued under the fixed designation C 943; the number immediately following the designation indicates the year of original adoption or, in the case of revision, the year of last revision. A number in parentheses indicates the year of last reappraisal. A superscript epsilon (ϵ) indicates an editorial change since the last revision or reappraisal.

1. Scope

1.1 This practice covers procedures for making standard test cylinders used to determine the compressive strength and density of preplaced-aggregate (PA) concrete.

1.2 The values stated in SI units are to be regarded as the standard. The values given in parentheses are for information only.

1.3 *This standard does not purport to address all of the safety concerns, if any, associated with its use. It is the responsibility of the user of this standard to establish appropriate safety and health practices and determine the applicability of regulatory limitations prior to use.*

2. Referenced Documents

2.1 ASTM Standards:

C 192/C 192M Practice for Making and Curing Concrete Test Specimens in the Laboratory²

C 637 Specification for Aggregates for Radiation-Shielding Concrete²

C 937 Specification for Grout Fluidifier for Preplaced-Aggregate Concrete²

C 938 Practice for Proportioning Grout Mixtures for Preplaced-Aggregate Concrete²

C 939 Test Method for Flow of Grout for Preplaced-Aggregate Concrete (Flow Cone Method)²

C 940 Test Method for Expansion and Bleeding of Freshly Mixed Grouts for Preplaced-Aggregate Concrete in the Laboratory²

3. Summary of Practice

3.1 Coarse aggregate is placed in a standard cylinder mold having end plates to which pipe fittings have been attached. Grout is pumped into the mold until full. The test cylinder,

demolded after hardening, may be cured and used for determination of strength or cut into prisms for the determination of unit weight.

4. Significance and Use

4.1 This practice is used for making test cylinders or prisms of PA concrete. Cylinders are used for determining compressive strength and approximate density. Prisms, cut from cylinders, eliminate the surface effect and thus more accurately represent the actual density of PA concrete in place.

5. Apparatus

5.1 *Cylinder Molds* (Fig. 1), cast iron or steel, for making 150 by 300-mm (6 by 12-in.) cylinders. Base and top plates shall be arranged for tight assembly to the cylinder. All mating and inside surfaces shall be machined smooth such that the assembled mold will be essentially watertight. End plates shall be drilled and tapped at their centers for standard 19 mm ($\frac{3}{4}$ -in.) pipe nipples. The top end plate shall also be perforated, as shown in Fig. 2.

5.2 *Venting Fabric*, white cotton cloth, free of oil and grease.

5.3 *Grouting Apparatus* (Fig. 3), capable of delivering grout at a uniform rate of 1.4 to 2.8 L (0.05 to 0.10 ft³)/min at pressures up to 345 kPa (50 psi).

5.4 *Mallet*, with rubber or rawhide head weighing approximately $\frac{1}{4}$ kg ($\frac{1}{2}$ lb).

5.5 *Platform Scales*, accurate to within 0.3 % of the test load at any point within the range of use.

5.6 *Stop Watch*, least reading not more than 0.2 s.

5.7 *Flow Cone*—See Test Method C 939.

5.8 *Thermometer*, accurate to 0.5°C (1°F), for measuring ambient and grout temperatures.

6. Materials

6.1 *Coarse Aggregate*—Except when tests are made for specific projects, coarse aggregate shall conform to the requirements of Specification C 637, Table number 2, Coarse Aggregate, Grading 1, unless Grading 2 is specified.

¹ This practice is under the jurisdiction of ASTM Committee C09 on Concrete and Concrete Aggregates and is the direct responsibility of Subcommittee C09.41 on Concrete for Radiation Shielding.

Current edition approved Dec. 10, 2002. Published February 2003. Originally approved in 1980. Last previous edition approved in 1996 as C 943–96.

² *Annual Book of ASTM Standards*, Vol 04.02.

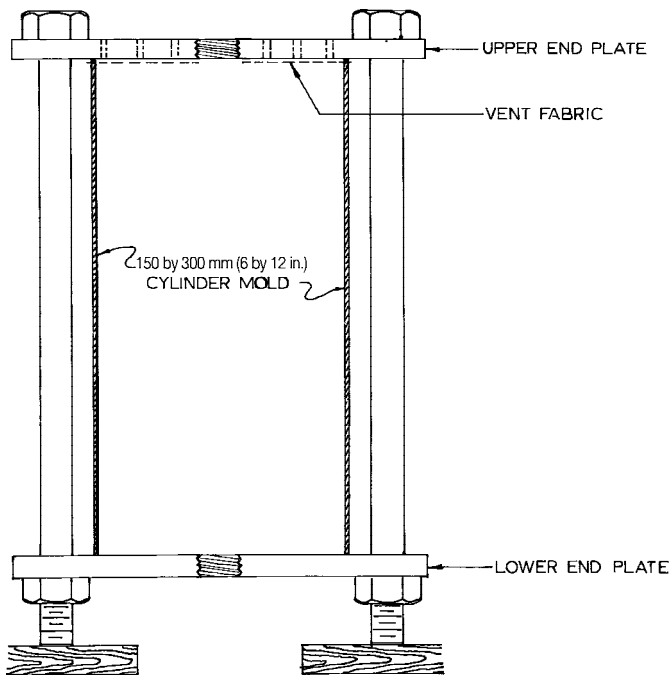

FIG. 1 Cylinder Mold Assembly Cross Section

6.2 *Grout*—Except when tests are made for specific projects, grout ingredients, proportioning, and mixing shall be in accordance with Practice C 938.

6.3 *Tests for Specific Projects*—When tests are to be made for specific projects, materials shall be representative of those in use or proposed for use in the work.

6.3.1 If not taken from project-mixed grout being used in the work, grout materials shall be mixed in the laboratory using the procedure described in Specification C 937.

7. Sampling

7.1 Coarse aggregate shall be representative of material used or to be used in the work or of that tested and stockpiled for test work.

7.2 Grout to be used in making PA concrete cylinders shall be typical of the batch from which it is drawn.

8. Preparation and Measurement of Prisms

8.1 When the determination of unit weight is required, prisms shall be cut from the central portions of the cylinders to dimensions as close as feasible to 101 by 101 by 254 mm (4 by 4 by 10 in.). Weigh the specimen to an accuracy of at least 1 part in 250. Compute the volume from the averages of two measurements of each dimension, taken to the nearest 0.25 mm (0.01 in.).

9. Procedure

9.1 Temperature:

9.1.1 When test cylinders are prepared in the laboratory, bring all materials to and maintain the laboratory in a temperature range of $23.0 \pm 2.0^\circ\text{C}$ ($73.5 \pm 3.5^\circ\text{F}$).

9.1.2 When test cylinders are prepared in the field, record ambient temperature in the vicinity of test operation.

9.2 Place each cylinder mold upright on its bottom plate on a firm, level surface.

9.3 Place the coarse aggregate in the mold in three approximately equal layers. Consolidate each layer by striking the mold ten times around its periphery with the mallet. When the mold has been filled, strike off the contents so that no aggregate particle projects above the plane of the top of the mold.

9.4 Place a single layer of venting fabric, in which a hole has been cut to match the 19-mm ($\frac{3}{4}$ -in.) hole in the top end plate, over the aggregate. Place the top plate on the mold, install bolts, and tighten. Attach the top and bottom valve assemblies and prepare to connect to hose from grout pump, as shown in Fig. 3.

9.5 Measure flow (Test Method C 939) and temperature of the representative sample of grout. Pour 800 ± 10 mL into a 1000-mL graduate for observation of expansion and bleeding, Test Method C 940.

9.6 If grout consistency is satisfactory, charge grout hopper and pump to waste until all water and diluted grout in the pump system has been expelled. Divert the grout flow to recirculation (to hopper) and make the connection to the bottom of the cylinder mold at valve 3, shown in Fig. 3.

9.7 With valves 2, 3, and 4 open, fill the cylinder slowly by partially closing bypass valve 1. When grout flows freely through upper plug valve 4, open bypass and close valves 2 and 4. Apply 70 to 100 kPa (10 to 15 psi) air pressure on the sample for 30 ± 5 s through air valve 5; then close valve 3. Move the grout supply line to succeeding cylinders in turn and repeat the above procedure for each.

9.7.1 The total elapsed time for intruding and pressurizing a cylinder mold shall be between $1\frac{1}{2}$ and 3 min.

9.7.2 Grout, if continually agitated, may be used for intruding PA cylinders for as long as 30 min after original mixing provided no additional water is added and fluidity remains under 35 s, flow cone, Test Method C 939.

9.8 After grout expansion is complete, as determined by observation of the specimen set aside for the purpose, 9.5, remove the upper valve assembly and install a pipe plug in the center hole of the upper plate. Using care to avoid jarring the specimen, invert the cylinder, remove valve 3 assembly, and install a pipe plug in the center hole of the lower plate. Carefully turn the assembly back to its original position. Clean valves and fittings immediately upon removal from end plates.

10. Handling and Curing

10.1 Do not disturb the specimen after removal of valve assemblies for at least 24 h. Then strip molds and cure cylinders in accordance with the section on Curing of Practice C 192/C 192M.

10.2 Protect field-made specimens during initial storage period in the molds from direct sunlight or freezing temperatures. When large amounts of pozzolan are used in the grout mixture or in cool curing conditions, delay stripping of cylinders to avoid damaging the specimens.

11. Report

11.1 Report the following information:

11.1.1 Identification of specimens, date cast, and whether done in laboratory or field.

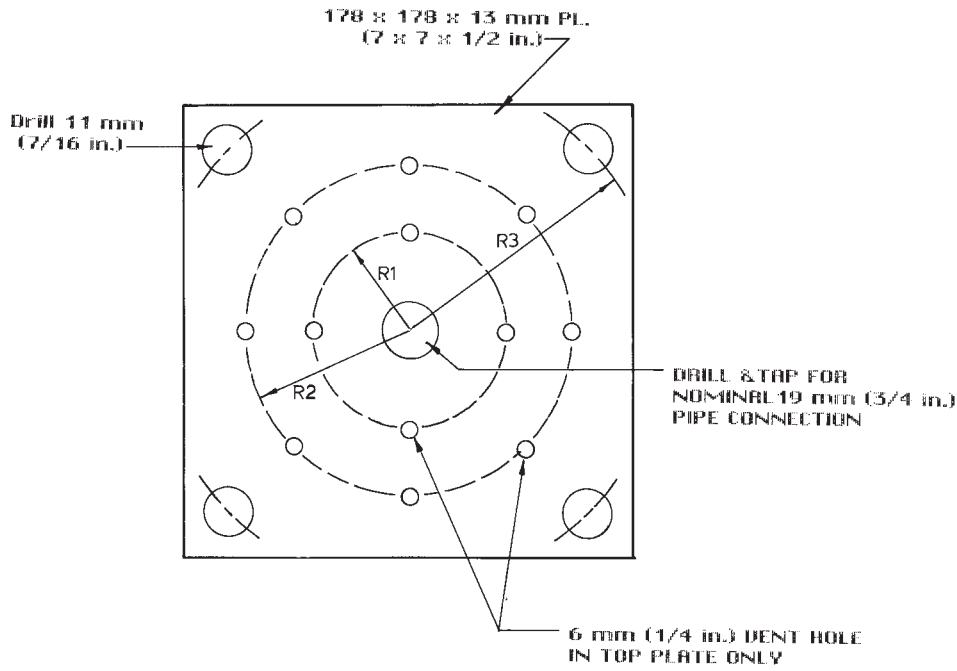

R1=38 mm (1 1/2 in.)
R2=64 mm (2 1/2 in.)
R3=101 mm (4 in.)

FIG. 2 End Plate Details

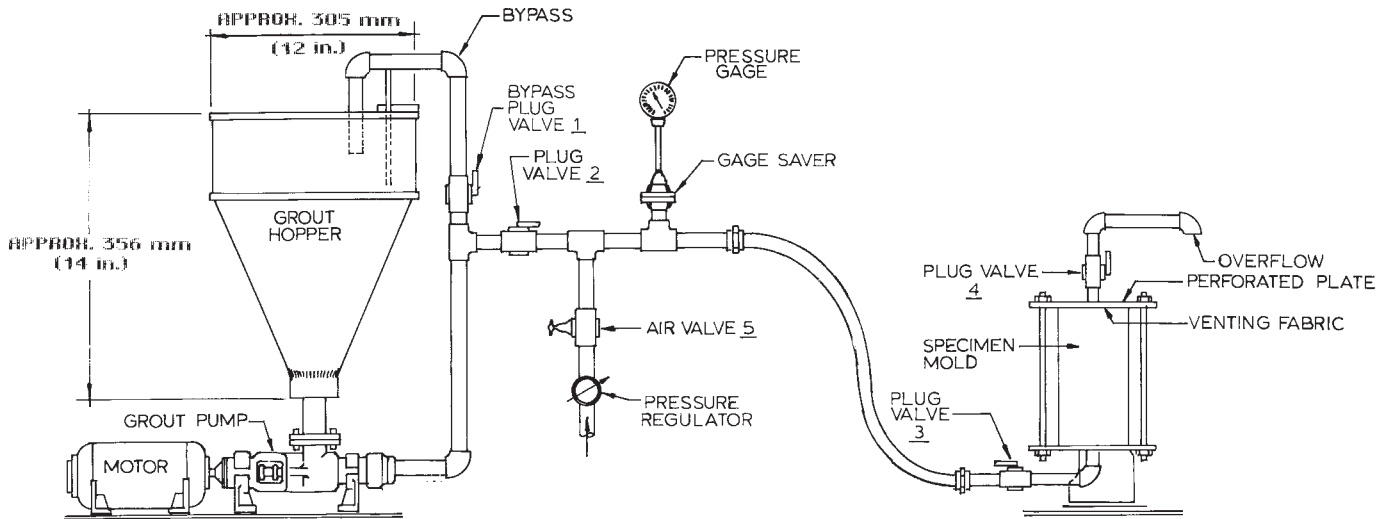

NOTE 1—Grout hose pipe and fittings 25 mm (1 in.) nominal.

FIG. 3 Typical Grouting Apparatus

- 11.1.2 Description of fine and coarse aggregate.
- 11.1.3 Identification of cementing materials and admixtures.
- 11.1.4 Description of grout including proportions, flow, temperature, expansion, and bleeding.
- 11.1.5 Temperatures at which the specimens were made and cured.

12. Keywords

- 12.1 cylinders; density; flow cone; grout; grouting apparatus; preplaced-aggregate; prisms; strength

ASTM International takes no position respecting the validity of any patent rights asserted in connection with any item mentioned in this standard. Users of this standard are expressly advised that determination of the validity of any such patent rights, and the risk of infringement of such rights, are entirely their own responsibility.

This standard is subject to revision at any time by the responsible technical committee and must be reviewed every five years and if not revised, either reapproved or withdrawn. Your comments are invited either for revision of this standard or for additional standards and should be addressed to ASTM International Headquarters. Your comments will receive careful consideration at a meeting of the responsible technical committee, which you may attend. If you feel that your comments have not received a fair hearing you should make your views known to the ASTM Committee on Standards, at the address shown below.

This standard is copyrighted by ASTM International, 100 Barr Harbor Drive, PO Box C700, West Conshohocken, PA 19428-2959, United States. Individual reprints (single or multiple copies) of this standard may be obtained by contacting ASTM at the above address or at 610-832-9585 (phone), 610-832-9555 (fax), or service@astm.org (e-mail); or through the ASTM website (www.astm.org).