



## Standard Test Method for Compression-Recovery of Tape Sealant<sup>1</sup>

This standard is issued under the fixed designation C 972; the number immediately following the designation indicates the year of original adoption or, in the case of revision, the year of last revision. A number in parentheses indicates the year of last reapproval. A superscript epsilon ( $\epsilon$ ) indicates an editorial change since the last revision or reapproval.

### 1. Scope

1.1 This test method describes a laboratory procedure for determining compression-recovery characteristics of tape sealant.

1.2 The values stated in SI units are to be regarded as the standard. The values given in parentheses are for information only.

1.3 *This standard does not purport to address all of the safety concerns, if any, associated with its use. It is the responsibility of the user of this standard to establish appropriate safety and health practices and determine the applicability of regulatory limitations prior to use.*

NOTE 1—There are no ISO standards similar or equivalent to this ASTM standard.

### 2. Referenced Documents

2.1 *ASTM Standards:*<sup>2</sup>

**C 717** Terminology of Building Seals and Sealants

### 3. Terminology

3.1 *Definitions*—For definitions of terms used in this test method, refer to Terminology **C 717**.

### 4. Significance and Use

4.1 Tape sealants are tacky, deformable solids used under compression between two or more surfaces of similar or dissimilar materials in a variety of sealing applications. This procedure presents an indication of the compression recovery characteristics of preformed tapes.

### 5. Apparatus

5.1 *Glass Plates*, two, each 6.35 by 76.2 by 76.2 mm (0.25 by 3 by 3 in.).

5.2 *Steel Panels*, two, cold-rolled, each 0.762 by 76.2 by 76.2 mm (0.03 by 3 by 3 in.).

NOTE 2—Substitutes such as aluminum, acrylic, acrylonitrile-butadiene-styrene (ABS), may be substituted for the plates (5.1) and panels (5.2).

5.3 *Compression Testing Machine*, with a cross-head speed of 50 mm (2 in.)/min and capable of stopping at specified settings.

NOTE 3—Load values may differ when determined on screw-type versus spring-type test machines due to a drift past the desired stop in the spring-type machine. It may be necessary to use shims to obtain the desired stop.

5.4 *Recorder*, for recording compression loads in newtons (or pounds-force).

5.5 *Stop Watch*, measuring in minutes and seconds.

5.6 *Gage or Rule*, capable of measuring tape thickness to 0.025 mm or 0.001 in.

### 6. Test Specimen and Sample

6.1 *Conditioning:*

6.1.1 Condition the specimens for 24 h at  $23 \pm 2^\circ\text{C}$  ( $73.4 \pm 3.6^\circ\text{F}$ ) and  $50 \pm 10\%$  relative humidity.

6.1.2 Other conditioning parameters may be included as desired.

6.2 Samples to be tested shall be taken from a roll or tape sealant after first removing and discarding approximately the first 0.6 m (2 ft) of the roll.

6.3 Tape sealant configuration should be approximately 9.53 by 9.53 by 76.2 mm (0.375 by 0.375 by 3 in.). The sample should be re-extruded rather than plied to conform to the specified size if the sample does not approximate these dimensions.

6.4 Total tape volume ( $V$ ) should be calculated (width by length by thickness) for determination of tape sealant compression index.

6.5 Prepare two test specimens for each sample as follows:

6.5.1 Do not clean or unnecessarily handle the surfaces of surface-treated or painted plate or panels.

6.5.2 Clean plates or panels with detergent or solvent, or both.

6.5.3 Place two 76.2 by 9.53 by 9.53-mm (3 by 0.375 by 0.375-in.) lengths of tape sealant on one of the plates or panels, as shown in **Fig. 1**, and remove the release paper. Place the second plate or panel over the tape sealant to complete the test specimen in accordance with **Fig. 1**.

<sup>1</sup> This test method is under the jurisdiction of ASTM Committee C24 on Building Seals and Sealants and is the direct responsibility of Subcommittee C24.20 on General Test Methods.

Current edition approved May 1, 2006. Published May 2006. Originally approved in 1982. Last previous edition approved in 2000 as C 972 – 00.

<sup>2</sup> For referenced ASTM standards, visit the ASTM website, [www.astm.org](http://www.astm.org), or contact ASTM Customer Service at [service@astm.org](mailto:service@astm.org). For *Annual Book of ASTM Standards* volume information, refer to the standard's Document Summary page on the ASTM website.

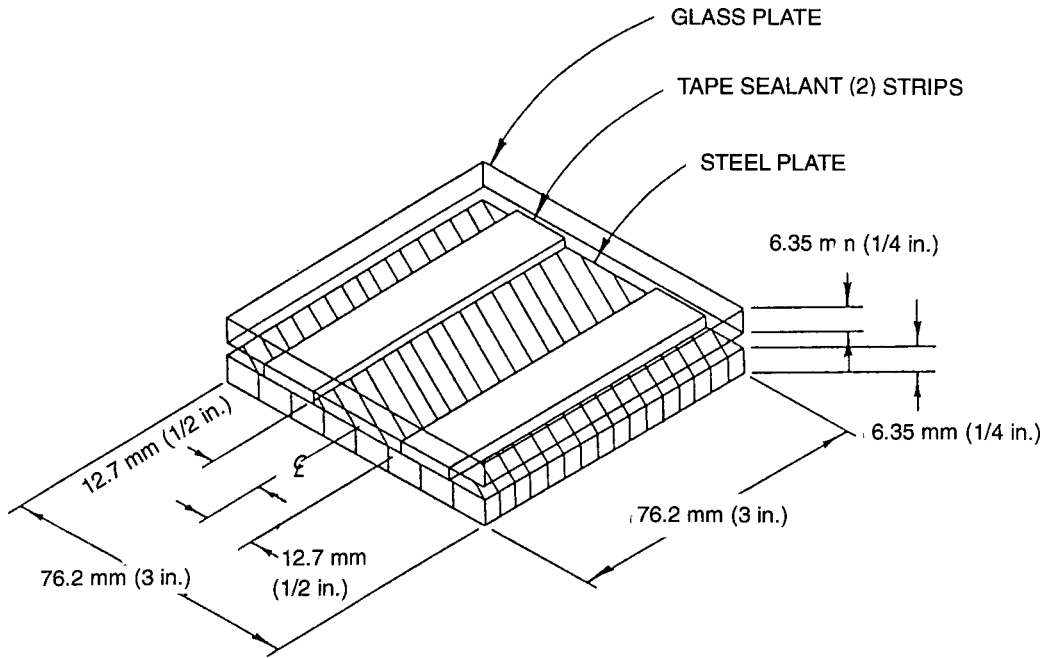

FIG. 1 Compression Recovery Test Sample

**7. Procedure**

7.1 Place the specimen in a laboratory press or equivalent equipment, and compress the specimen at 51 mm (2 in.)/min until the sealant tape thickness is 5.1 mm (0.20 in.). Maintain the compression mode for exactly 1 min, recording maximum compressive load in newtons or pounds force. At the end of 1 min, raise the press crosshead and remove the specimen, taking care not to disturb the specimen.

7.2 After removing the specimen from the press, measure and record the tape sealant thickness after 5 min and after 2 h.

**8. Calculations**

8.1 Calculate the compression load and recovery height for each specimen as follows:

$$R_1 = T_1 - 5.1 \text{ mm (0.200 in.)} \quad (1)$$

where:

$R_1$  = free recovery height after 5 min, and  
 $T_1$  = tape thickness after 5 min.

$$R_2 = T_2 - 5.1 \text{ mm (0.200 in.)} \quad (2)$$

where:

$R_2$  = free recovery height after 2 h, and  
 $T_2$  = tape thickness after 2 h.

$$P_c = P/V \quad (3)$$

where:

$P_c$  = tape compression index, N/mm<sup>3</sup>(lbf/in.<sup>3</sup>),  
 $P$  = maximum compression load, N (lbf), and  
 $V$  = total tape sealant volume, mm<sup>3</sup>(in.<sup>3</sup>).

**9. Report**

9.1 The report shall include the following:

- 9.1.1 Average recovery height after 5 min and after 2 h to the nearest 5.1 mm (0.001 in.),
- 9.1.2 Average tape sealant compression index in newtons per cubic millimetre (or pounds-force per cubic inch), and
- 9.1.3 Type of compression equipment used.

**10. Precision and Bias <sup>3</sup>**

10.1 Three laboratories were used in the force to compress testing and four laboratories were used for both recovery tests (5 min and 2 h).

10.2 *Repeatability I(r)*—The repeatability interval (within a given laboratory) for four materials tested by three (or four) laboratories is listed in Table 1 for each of the calculated values defined in Section 8.

10.3 *Reproducibility I(R)*—The reproducibility interval (between given laboratories) for four materials tested by three (or

<sup>3</sup> Supporting data are available from ASTM Headquarters. Request RR: C24-1008.

TABLE 1 Indexes of Precision

Source of Variability	Symbol	Force to Compress, N (lbf)	Recovery, 5 min, mm (in.)	Recovery, 2 h, mm (in.)
Repeatability (within laboratory)	$I(r)$	50.5 (11.34)	0.43 (0.017)	0.30 (0.012)
Reproducibility (between laboratories)	$I(R)$	443.0 (99.56)	0.76 (0.030)	0.76 (0.030)

four) laboratories is listed in **Table 1** for each of the calculated values defined in Section 8.

## 11. Keywords

### 11.1 compression; recovery; tape sealant

*ASTM International takes no position respecting the validity of any patent rights asserted in connection with any item mentioned in this standard. Users of this standard are expressly advised that determination of the validity of any such patent rights, and the risk of infringement of such rights, are entirely their own responsibility.*

*This standard is subject to revision at any time by the responsible technical committee and must be reviewed every five years and if not revised, either reapproved or withdrawn. Your comments are invited either for revision of this standard or for additional standards and should be addressed to ASTM International Headquarters. Your comments will receive careful consideration at a meeting of the responsible technical committee, which you may attend. If you feel that your comments have not received a fair hearing you should make your views known to the ASTM Committee on Standards, at the address shown below.*

*This standard is copyrighted by ASTM International, 100 Barr Harbor Drive, PO Box C700, West Conshohocken, PA 19428-2959, United States. Individual reprints (single or multiple copies) of this standard may be obtained by contacting ASTM at the above address or at 610-832-9585 (phone), 610-832-9555 (fax), or [service@astm.org](mailto:service@astm.org) (e-mail); or through the ASTM website ([www.astm.org](http://www.astm.org)).*