



Standard Test Method for Bond Strength of Mortar to Masonry Units¹

This standard is issued under the fixed designation C 952; the number immediately following the designation indicates the year of original adoption or, in the case of revision, the year of last revision. A number in parentheses indicates the year of last approval. A superscript epsilon (ϵ) indicates an editorial change since the last revision or reapproval.

This standard has been approved for use by agencies of the Department of Defense.

^e1 NOTE—Editorial changes were made throughout in December 2003.

1. Scope*

1.1 This test method provides two procedures for measuring bond strength of mortar to masonry units: a crossed brick couplet tensile test for evaluating mortar-brick bond strength and a stacked-bond, flexural test for evaluating mortar-concrete block bond strength.

1.2 *This standard does not purport to address the safety concerns, if any, associated with its use. It is the responsibility of the user of this standard to establish appropriate safety and health practices and determine the applicability of regulatory limitations prior to use.*

2. Referenced Documents

2.1 ASTM Standards:

- C 67 Test Methods of Sampling and Testing Brick and Structural Clay Tile²
- C 90 Specification for Loadbearing Concrete Masonry Units²
- C 129 Specification for Nonloadbearing Concrete Masonry Units²
- C 140 Test Methods of Sampling and Testing Concrete Masonry Units and Related Units²
- C 270 Specification for Mortar for Unit Masonry²
- C 780 Test Method for Preconstruction and Construction Evaluation of Mortars for Plain and Reinforced Unit Masonry²
- C 1072 Test Method for Measurement of Masonry Flexural Bond Strength²
- C 1357 Test Method for Evaluating Masonry Bond Strength²
- C 1437 Test Method For Flow of Hydraulic Cement Mortar³

¹ This test method is under the jurisdiction of ASTM Committee C15 on Manufactured Masonry Units and is the direct responsibility of Subcommittee C15.04 on Research. Committee E-6 maintains a continued interest in these practices and will make use of them in the future.

Current edition approved December 10, 2002. Published March 2003. Originally published as E 149 – 59 T. Redesignated C 952 – 76 in 1981. Last previous edition C 952 – 91 (1997).

² Annual Book of ASTM Standards, Vol 04.05.

³ Annual Book of ASTM Standards, Vol 04.01.

E 518 Test Methods for Flexural Bond Strength of Masonry²

3. Significance and Use

3.1 These procedures are useful for research into bond strength of masonry. They are not intended to predict the bond strength of commercial masonry construction. The bond strength in commercially built structures is determined by many factors beyond the characteristics of mortar, masonry units, and the procedures of this test method.

NOTE 1—The crossed-brick couplets method measures a direct tensile strength of the bond between the mortar and masonry unit. It does not determine the flexural strength of the unit mortar assembly. Other test methods may be more appropriate for determining the flexural bond strength between mortar and masonry units. These include, C 1072 Test Method for Measurement of Masonry Flexural Bond Strength, C 1357 Test Methods for Evaluating Masonry Bond Strength, and E 518 Test Methods for Flexural Bond Strength of Masonry.

PREPARATION AND TESTING OF FRESH MORTAR

4. Preparation of Mortar

4.1 Proportion mortar materials by weights equivalent to volume proportions to be used in prism construction. Use unit weights for individual materials as given in Specification C 270. Sand shall be permitted to be used in a damp loose condition, provided that moisture content of sand is determined with reference to the oven-dried condition and batch proportions are adjusted accordingly. Record weight of ingredients (including water) added to the batch of mortar.

4.2 Mix mortar in a mechanical paddle-type mortar mixer. Time periods referenced below are measured from when water and cementitious materials are combined.

4.2.1 Add an estimated amount of water to the mortar to achieve the desired consistency (Note 2). Mix mortar for three minutes and determine consistency. If the desired consistency is specified by flow determine it in accordance with Test Method C 1437. If the desired consistency is specified as initial cone penetration, determine it in accordance with Test Method C 780. Once consistency is recorded, return the material used to measure the consistency to the mixer. If the consistency is within the desired range, continue mixing the batch for an

*A Summary of Changes section appears at the end of this standard.

additional two minutes. If the consistency is less than the desired range, add water to the batch and mix for one minute and determine consistency. Once consistency is recorded, return the material used to measure consistency to the mixer. If the consistency is within the desired range, continue mixing the batch for one minute.

NOTE 2—Workable consistency of mortar for concrete masonry construction generally requires an initial cone penetration reading of 55 ± 5 mm or a flow of 125 ± 5 %. Workable consistency of mortar for clay masonry construction generally requires an initial cone penetration reading of 65 ± 5 mm or a flow of 135 ± 5 %. Optimum consistency for a specific mortar-unit combination may differ from these values.

4.2.2 If after the one-time addition of water the consistency is not in the desired range, discard the batch.

4.2.3 If the measured consistency exceeds the desired range at any time, discard the batch.

4.3 Immediately after mixing the mortar, determine its initial cone penetration in accordance with Test Method C 780. Determine the cone penetration of the mortar every 15 ± 5 minutes. If the cone penetration is less than 80 % of its initial value, discard the remaining portion of the mortar without constructing additional mortar joints.

PREPARATION AND TESTING OF BOND STRENGTH TEST SPECIMENS

5. Apparatus

5.1 *Miscellaneous*—Brass-covered mortar board 18 in. (457 mm) square, an 11-in. (279-mm) long mason’s trowel, laboratory trowel with straight edges, short handled spoon or scoop of $\frac{1}{4}$ -cup (0.5-dm^3) capacity, steel straightedge 10 in. (254 mm) long, metal mold $\frac{1}{2}$ in. (13 mm) deep with $3\frac{5}{8}$ -in. (92-mm) square opening beveled to slope of 0.08 (total 0.04), splash board (Fig. 1) with handle 20 in. (508 mm) long and 3 in. (76 mm) wide.

5.2 *Drop Hammer* for crossed-brick couplets (Fig. 2, Table 1).

5.3 *Drop Hammer* for block assemblies (Fig. 3).

5.4 *Loading Jigs* for crossed-brick couplets (Fig. 4).

5.5 *Frames* (Fig. 5) for testing block assemblies: upper frame fitted with ball bearing mounted 10 in. (254 mm) from vertical axis of specimen for eccentric application of vertical load. .

5.6 *Torque Wrench*.

6. Crossed-Brick Couplets

6.1 *Brick*—Test specimens consisting of crossed-brick couplets may be used to determine:

6.1.1 Bond between specified brick and a specified mortar,

6.1.2 Relative bond between different brick and a specified mortar, or

6.1.3 Relative bond between a specified brick and different mortars.

6.1.4 In each case, the initial rate of absorption of the brick shall be determined in accordance with Test Methods C 67. The brick used for couplets shall include the full range of absorption rates acceptable under the specifications.

6.2 *Construction of Test Specimens*:

6.2.1 Center the mold on the lower brick of the couplet and lightly mix a small quantity of mortar on the board by turning over with the spoon.

6.2.2 Half-fill the mold by sharply dashing into each corner and the center of the mold a small quantity of mortar from the half-filled spoon. Note the time at start of a 1-min interval. Apply additional mortar by heaping loosely with the spoon above the top of the mold. Strike off excess mortar with the straightedge, starting on a diagonal across the mold and working first to one corner and then to the opposite corner of the mold. Remove the mold from the mortar bed.

6.2.3 At the end of the 1-min time interval, place the upper brick on the mortar bed in a crosswise direction to the lower brick. Place the frame of the hammer on the top brick with the weight of the hammer held in the other hand. Drop the hammer in a frame a distance of $1\frac{1}{2}$ in. (38 mm).

6.2.4 Measure and record the extrusion of the mortar on the top surface of the lower brick. Cut away extruded mortar from all four edges of the mortar bed.

6.3 *Curing*—Promptly enclose the test specimen within an airtight covering. Keep covered for 7 days. Remove the cover and store until tested. Unless otherwise specified, the specimen shall be stored in laboratory air at a relative humidity of at least 50 %.

6.4 *Testing*—Center the specimen between the upper and lower tripods and place in the testing machine as shown in Fig. 6. Load the specimen at the rate of 600 lb (2.7 kN)/min or at a rate sufficient to cause failure in 1 to 2 min. Note and record maximum load and type of failure.

NOTE 3—The method of making the specimens typically produces a failure of the joint at the top of the mortar bed.



FIG. 1 Splash Board

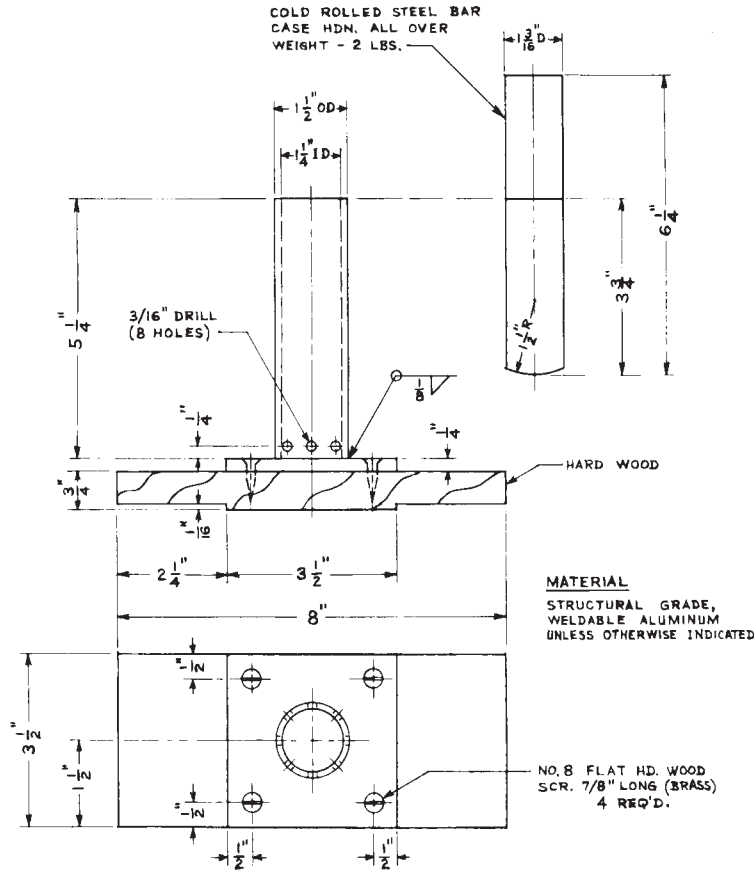

FIG. 2 Drop Hammer for Cross-Brick Couplets

TABLE 1 Metric Equivalents for Figs. 2, 3, 4, 5, and 6

Inch-Pound	Metric	Inch-Pound	Metric	Inch-Pound	Metric
1/16 in.	1.6 mm	1 3/4 in.	44 mm	5 in.	127 mm
1/8 in.	3 mm	1 7/8 in.	48 mm	5 1/4 in.	133 mm
3/16 in.	4.7 mm	2 in.	51 mm	5 3/4 in.	146 mm
1/4 in.	6.4 mm	2 1/8 in.	54 mm	6 in.	152 mm
5/16 in.	7.9 mm	2 1/4 in.	57 mm	6 1/4 in.	159 mm
7/16 in.	11 mm	2 3/8 in.	61 mm	7 1/2 in.	190 mm
1/2 in.	12.7 mm	2 1/2 in.	64 mm	8 in.	203 mm
5/8 in.	15.8 mm	2 5/8 in.	67 mm	8 1/2 in.	216 mm
3/4 in.	19 mm	3 in.	76 mm	9 3/4 in.	248 mm
7/8 in.	22 mm	3 1/8 in.	79 mm	10 3/4 in.	273 mm
1 in.	25 mm	3 1/4 in.	82 mm	16 in.	406 mm
1 1/8 in.	28 mm	3 1/2 in.	89 mm	16 1/2 in.	419 mm
1 1/16 in.	30 mm	3 5/8 in.	92 mm	18 3/4 in.	476 mm
1 1/4 in.	32 mm	3 3/4 in.	95 mm	28 in.	711 mm
1 3/8 in.	35 mm	4 in.	102 mm	2 lb	0.9 kg
1 1/2 in.	38 mm	4 3/4 in.	121 mm	3.5 lb	1.6 kg

NOTE 4—Reproducibility of test results may be improved by the insertion of strips of high-density insulation board interlayers between the test specimen and test apparatus.

6.5 Calculation—Calculate the maximum tensile bond strength as follows:

$$\text{Tensile bond strength, } T, \text{ psi (or N/m}^2\text{)} = A/B \quad (1)$$

where:

- A = total applied load, lbf (or N), and
- B = cross-sectional area in bond, in.²(or m²).

7. Concrete Masonry Unit Assemblies

7.1 Concrete Masonry Units—Concrete masonry units used in test specimens shall conform to Specification C 90 or C 129. The moisture content of the concrete masonry units shall be as specified. In the absence of any other specified moisture content, the concrete masonry units shall be conditioned to have a moisture content of between 25 % and 35 % of total absorption, as determined in accordance with Test Methods C 140.

7.2 Construction of Test Specimens:

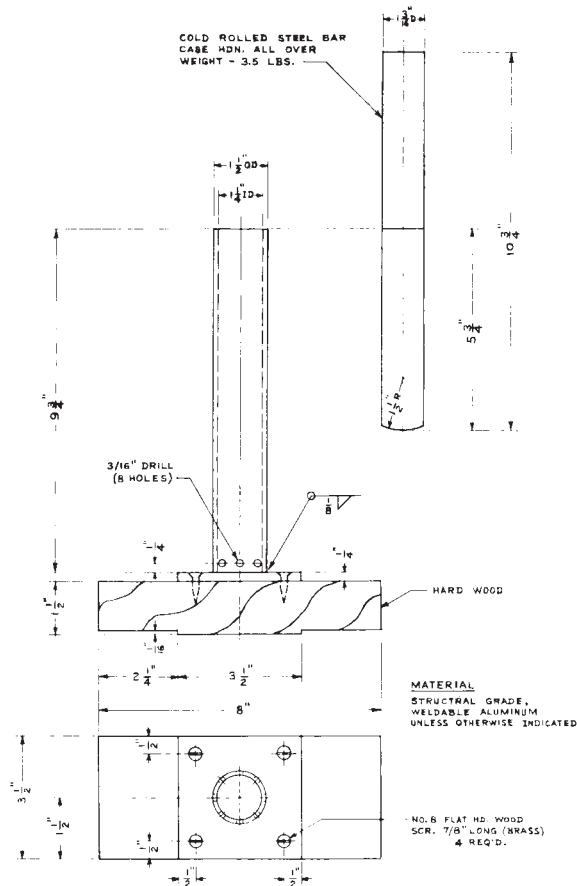

FIG. 3 Drop Hammer for Concrete Block Assemblies

7.2.1 Position the bottom concrete masonry unit of the assembly on a metal pallet with the thickest part of the face shells upwards. Lightly turn over and remix the mortar on the board with a mason's trowel.

7.2.2 With a mason's trowel and technique, apply mortar to the top of the face shell that will be in the compressive face of the specimen, when tested. The amount of mortar applied shall be sufficient to produce a bed joint of the desired thickness in the finished specimen (Note 5). In the absence of any specified thickness, the bed joints in the finished specimen shall be of a nominal $\frac{3}{8}$ -in. (9.5-mm) thickness.

NOTE 5—The consistency of the mortar, when made, and the amount of water used in the mortar shall have been adjusted to meet the requirements for the proper joint thickness of concrete masonry unit assemblies.

7.2.3 Hold the splash board along the top of the opposite face shell (the shell that will be in the tensile face of the specimen) and with the mason's trowel lightly loaded, sharply dash a thin bed of mortar on the top of this shell as shown in Fig. 7. Remove the splash board. Note the time for the start of a 1-min interval. Load the trowel and build up the mortar bed by gently rolling or dropping a sufficient amount of additional mortar.

7.2.4 At the end of the 1-min time interval, pick up and level the upper concrete masonry unit of the assembly on the mortar

beds by bringing the concrete masonry unit downward and forward to one end of the lower masonry unit. The upper concrete masonry unit shall be placed with the thin edge of the face shells in the mortar.

7.2.5 Immediately position the drop hammer frame at the center of the upper masonry unit, holding the weight of the hammer in the other hand. Drop the hammer in the tubular frame a distance of 4 in. (102 mm). Remove the drop hammer. No further adjustment of the top masonry unit on its bed shall be made.

7.2.6 Measure and record the extrusion of mortar from the faces of the specimen. Cut extruded mortar away with the mason's trowel. Tool the joints with a rounded iron.

7.3 *Curing*—Promptly enclose the specimen in an airtight covering. Keep covered for 7 days. Remove the cover and store until tested. Unless otherwise specified, the specimen shall be stored in laboratory air at a relative humidity of at least 50 %.

7.4 *Testing*—Clamp the specimen in the lower and upper test frames by tightening the screws of the test frames with a torque wrench (see Fig. 8). Center the ball bearing on the upper test frame in the testing machine. Apply a vertical load to the specimen at the rate of 600 lbf (2.7 kN)/min or at a rate sufficient to cause failure in 1 to 2 min.

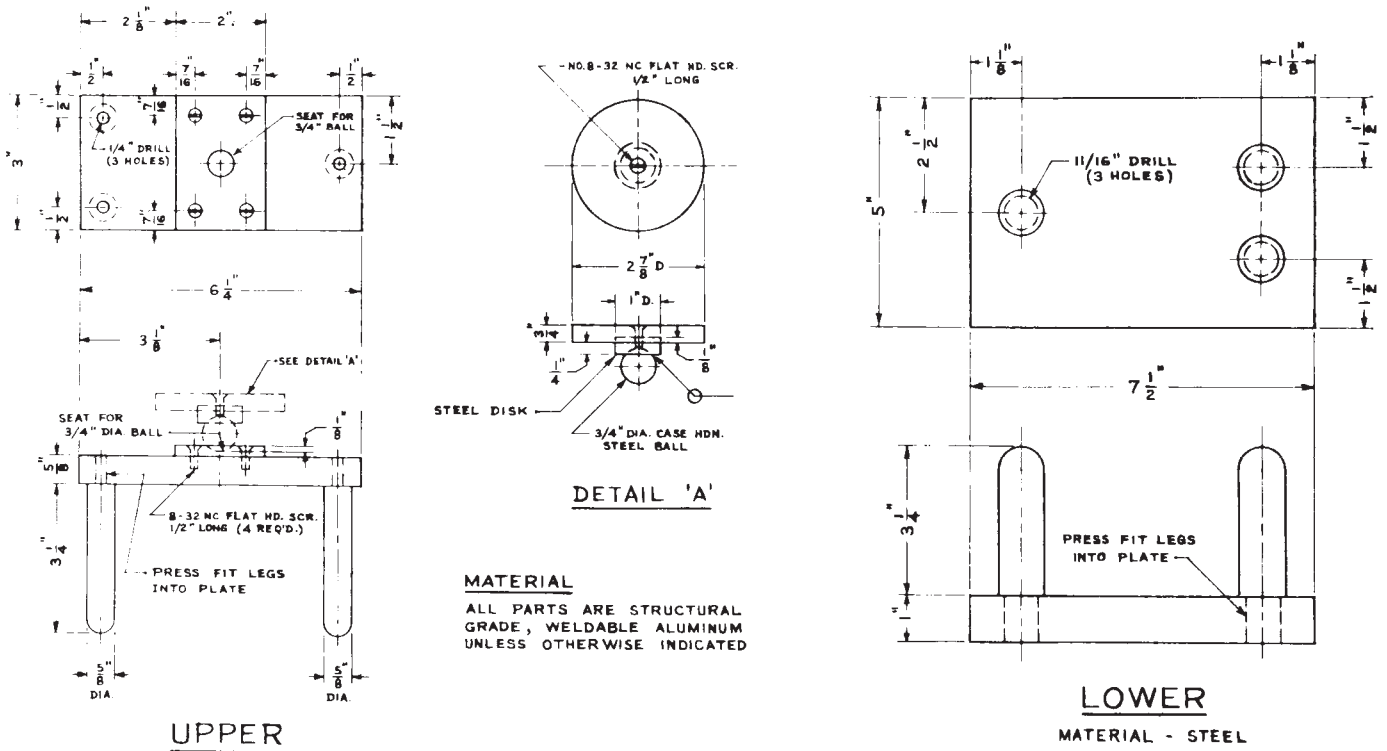

FIG. 4 Loading Jigs for Cross-Brick Couplets

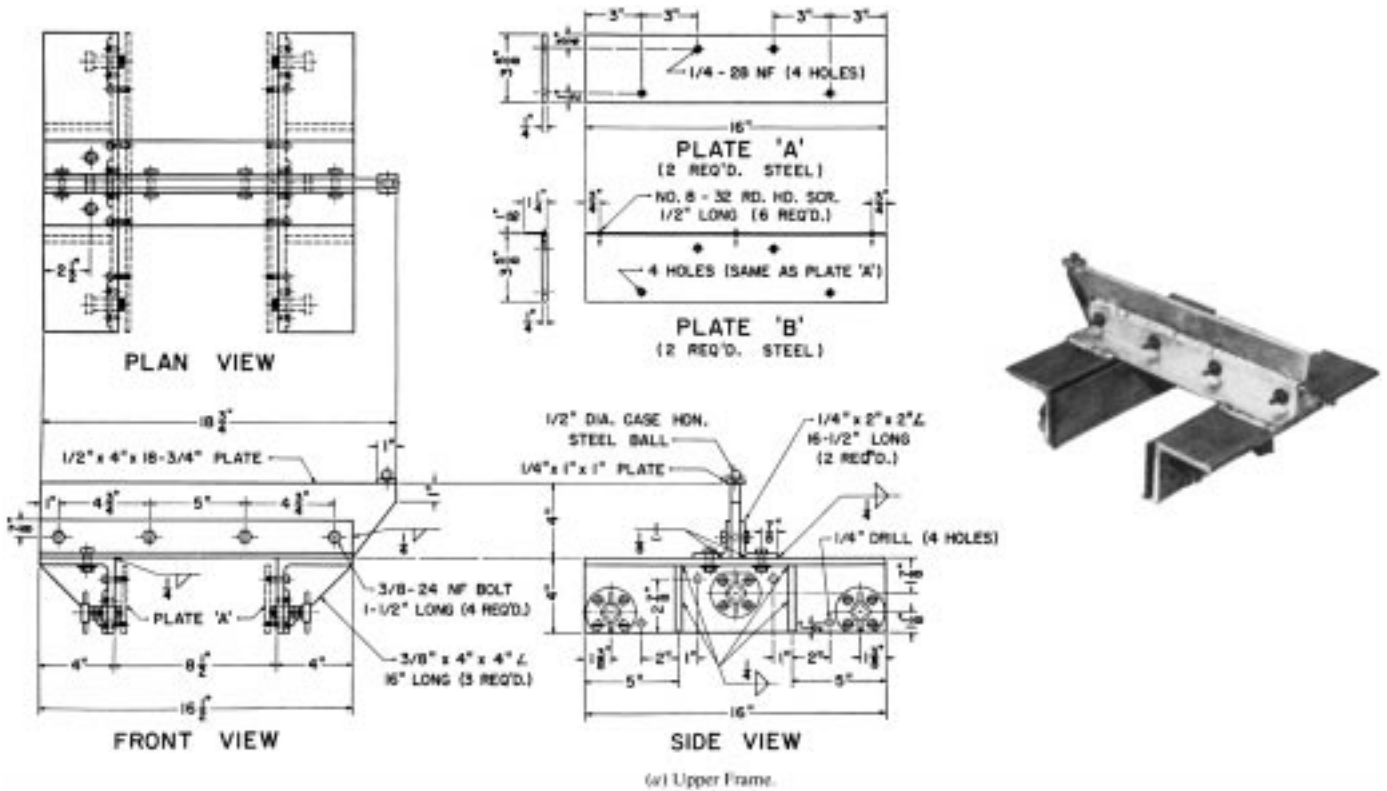

FIG. 5 Frames for Testing Concrete Block Assemblies

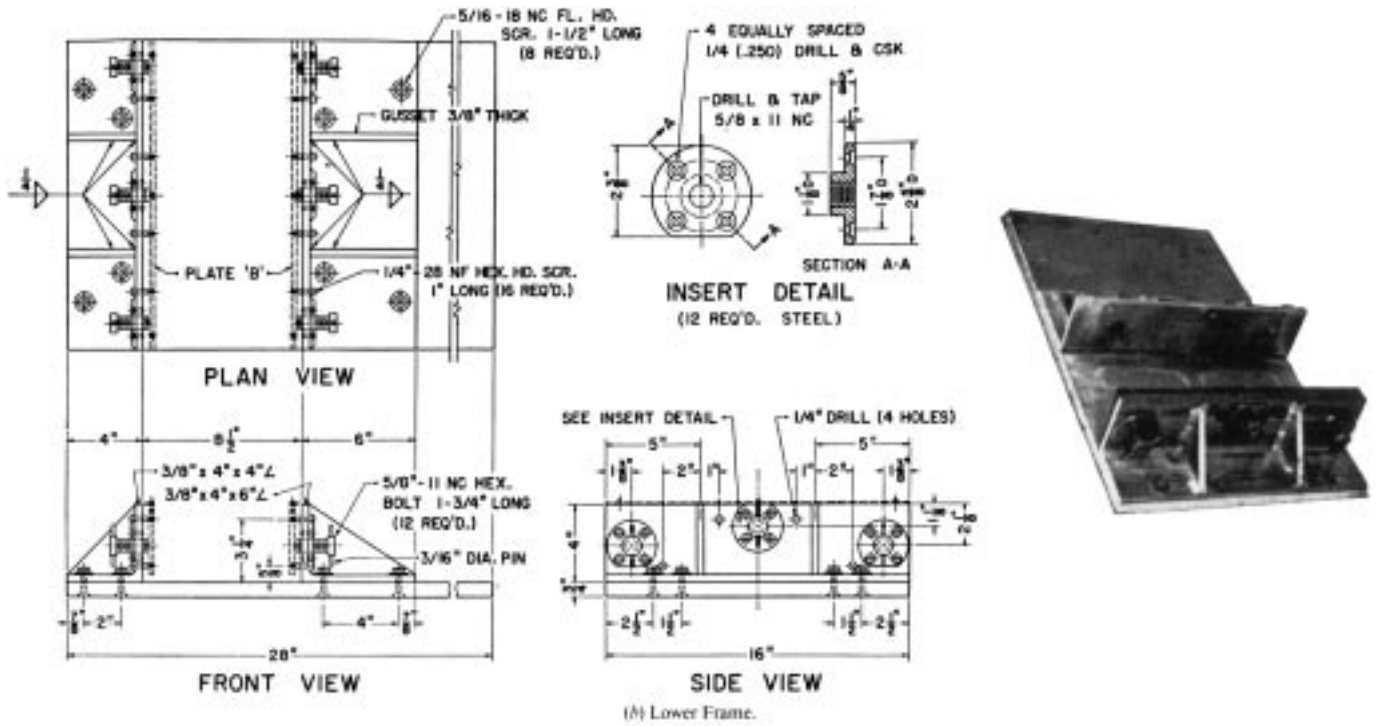

FIG. 5 Frames for Testing Concrete Block Assemblies (continued)



FIG. 6 Crossed-Brick Test Assembly Positioned in Testing Machine

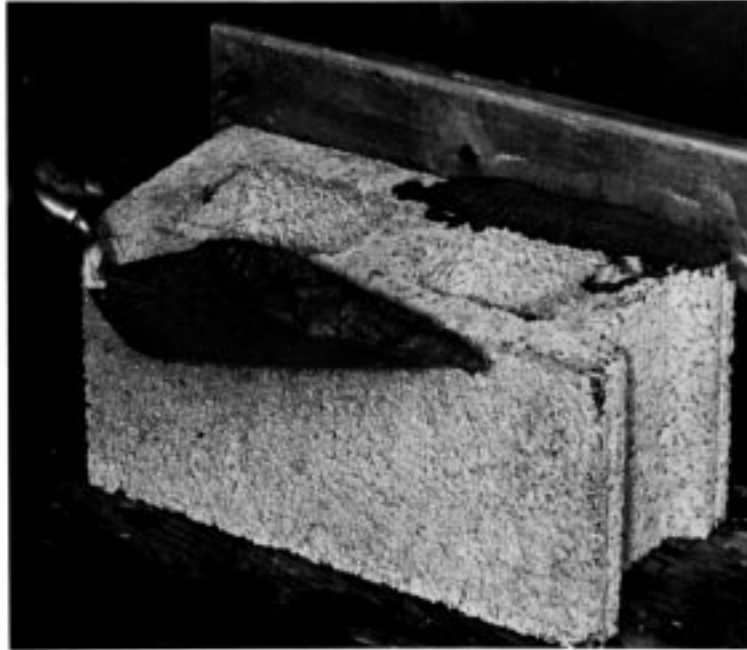

FIG. 7 Preparing Concrete Block Test Assembly



FIG. 8 Concrete Block Test Assembly Positioned in Testing Machine

7.5 Calculation—Calculate the maximum flexural bond strength of the section for the gross and the net section of the specimen, taken normal to the face shells, as follows:

$$\begin{aligned} f_g &= (xPc/I_g) - (P/A_g) \\ f_n &= (xPc/I_n) - (P/A_n) \end{aligned} \quad (2)$$

where:

f_g = flexural bond stress on gross area, psi (or N/m²)
 f_n = flexural bond stress on net area, psi (or N/m²),

x = lever arm of load about vertical axis of specimen, in. (or m),
 P = applied load, lbf (or N),
 c = distance from neutral axis to face of specimen, in. (or m),
 I_g = moment of inertia of gross section, in.⁴ (or m⁴),
 I_n = moment of inertia of net section, in.⁴ (or m⁴),
 b = length of masonry unit, in. (or m),
 d = width of masonry unit, in. (or m),

t = minimum thickness of face shell, in. (or m),
 A_g = gross area of section = bd , in.²(or m²), and
 A_n = net area of section = $2bt$, in.²(or m²).

8. Precision and Bias

8.1 Variability is a characteristic of tensile and flexural bond stresses. Round robin testing has not been performed on these

methods. Coefficients of variation of 15 to 35 % are commonplace in published investigations using the methods of this standard.

9. Keywords

9.1 bond; concrete masonry unit; crossed brick couplet; mortar; masonry

SUMMARY OF CHANGES

Committee C 12 has identified the location of selected changes to the standard since the C 952-91 (Reapproved 1998) version that may impact the use of this standard.

- (1) Section 2.1 was changed to add those standards that are now referenced by this standard and to eliminate those standards that are no longer referenced by this standard.
- (2) A note was added to Section 3 to direct the user to other test methods that may be more appropriate for their use.
- (3) The PREPARATION AND TESTING OF FRESH MORTAR section was modified by removing the old Sections 4 - 8 and replacing them with a new Section 4. All other sections and

notes were renumbered to reflect this change.

- (4) New Section 6.1.4 was modified.
- (5) New Sections 7.1, 7.2.1 and 7.2.4 were changed to reference 'masonry unit' instead of 'block'.
- (6) New Section 7.1 was changed to refer to Test Method C 140 for determining moisture content instead of Test Method C 427 for equivalent relative humidity.

ASTM International takes no position respecting the validity of any patent rights asserted in connection with any item mentioned in this standard. Users of this standard are expressly advised that determination of the validity of any such patent rights, and the risk of infringement of such rights, are entirely their own responsibility.

This standard is subject to revision at any time by the responsible technical committee and must be reviewed every five years and if not revised, either reapproved or withdrawn. Your comments are invited either for revision of this standard or for additional standards and should be addressed to ASTM International Headquarters. Your comments will receive careful consideration at a meeting of the responsible technical committee, which you may attend. If you feel that your comments have not received a fair hearing you should make your views known to the ASTM Committee on Standards, at the address shown below.

This standard is copyrighted by ASTM International, 100 Barr Harbor Drive, PO Box C700, West Conshohocken, PA 19428-2959, United States. Individual reprints (single or multiple copies) of this standard may be obtained by contacting ASTM at the above address or at 610-832-9585 (phone), 610-832-9555 (fax), or service@astm.org (e-mail); or through the ASTM website (www.astm.org).