

© British Standards Institution. No part of this publication may be photocopied or otherwise reproduced without the prior permission in writing of BSI

---

British Standard

# Testing concrete

Part 115. Specification for compression testing  
machines for concrete

---

Essais du béton

Partie 115. Machines d'essai en compression du béton. Spécifications

Prüfverfahren für Beton

Teil 115. Betondruckprüfmaschinen

## Foreword

This Part of ES 1881 revises clause 9 of BS 1881 : Part 115 : 1983, prepared under the direction of the Cement, Gypsum, Aggregates and Quarry Products Standards Committee, to clarify the use of the different methods for verifying the performance of compression testing machines and the frequency of checking parts of the machine. It supersedes BS 1881 : Part 115 : 1983 which is withdrawn.

This Part of BS 1881 gives specific requirements to enable compression testing machines to be used for testing concrete specimens. The requirements relate to control and measurement of the load, the geometry and hardness of the machine platens and the means of alignment that ensure correct load application.

In order to maintain its initially correct performance, annual checks are laid down for load verification by the methods in BS 1610 : Part 2 and for load application either by the proving device described in appendix A or by a comparative cube test. The comparative cube testing scheme provided by laboratories accredited by the British Calibration Service\* verifies the correctness of the whole testing procedure.

It should be possible to carry out all these checks when the machine undergoes an annual service. These checks will also be needed when a machine is moved to a new location or is subject to disturbance, major repairs or adjustments before it is used again to test concrete specimens.

Although the requirements relate mainly to machines used in the compressive strength test for concrete cubes many of the requirements are applicable to machines used in compression tests described in other Parts of BS 1881.

**Compliance with a British Standard does not of itself confer immunity from legal obligations.**

# Contents

	Page
<b>Foreword</b>	<b>Inside front cover</b>
<b>Committees responsible</b>	<b>Back cover</b>
<b>Specification</b>	
1 Scope	2
2 Definitions	2
3 General	2
4 Loading	2
5 Machine platens	2
6 Auxiliary platens	2
7 Spacing blocks	3
8 Location of specimen	3
9 Performance	3
<b>Appendix</b>	
A Proving device and proving procedure for concrete cube compression testing machines	5
<b>Figures</b>	
1 Gauging of cylinder	5
2 Auxiliary platen	6

# Specification

## 1 Scope

This Part of BS 1881 specifies the requirements, at manufacture, of machines used for the testing of concrete specimens in compression, and their subsequent verification. It mainly applies to the test for compressive strength of cubes but the principles and equipment are applicable to other forms of test using compression in other Parts of BS 1881.

**NOTE.** The titles of the publications referred to in this standard are listed on the inside back cover.

## 2 Definitions

For the purposes of this Part of BS 1881 the definitions given in BS 1610 : Parts 1 and 2 and BS 5328 apply.

## 3 General

Compression testing machines shall be related to the size of the specimen and the expected load, and shall comply with BS 1610 : Part 1 and clauses 4 to 9 of this Part of BS 1881.

## 4 Loading

### 4.1 Load control

The machine shall be capable of applying the load at the specified rate, uniformly, without shock, using manual or automatic control.

### 4.2 Load pacers

4.2.1 If the machine is not equipped with an automatic load control, a load pacer shall be fitted to enable the operator to manipulate the machine controls to maintain the specified rate.

4.2.2 If the pacer has a scale, this scale shall be basically linear such that 1 mm represents not more than 100 N/s. Over the operating range of the scale the accuracy shall be within  $\pm 5\%$ .

**NOTE.** The pacer may incorporate a scale with an indicator point or, alternatively, it may be, for example, a marked disc or pointer which rotates at the rate at which the load pointer should move on the load scales being used.

If the pacer is fitted with a variable speed control or has pre-set speeds, then once the variable speed control has been set, or a pre-set speed has been chosen, the pacer speed shall remain within  $\pm 5\%$  of the specified speed over the operating range.

### 4.3 Load scale indicators or digital displays

4.3.1 The machine shall be provided with the following.

- (a) Either easily read dials or scales which comply with BS 3693 : Part 2 or electrical load indicators with a visual display.

**NOTE.** The visual display may be supplemented by recording devices, e.g. punched tape or print-out recorders, that are calibrated to the same accuracy as the display.

- (b) A resettable device which registers the maximum load sustained by the specimen.

4.3.2 The machine scale range shall be chosen so that the specimens can be expected to fracture in that part of the range which is certified to be accurate to  $\pm 1\%$  or  $\pm 2\%$  of the indicated load (i.e. normally the upper four-fifths of the range).

**NOTE 1.** Machines accurate to  $\pm 1\%$  are preferred.

The grading of the machine in accordance with BS 1610 : Part 1 shall not be affected by variations in mains supply voltage or frequency of  $\pm 10\%$  from the nominal value supplied to the machine.

**NOTE 2.** Where electrical or other interference exists this may affect the accuracy of load indication, and special provisions to overcome this interference may be necessary.

### 4.4 Load verification

The machine scales or digital displays shall be verified at annual intervals and when a machine is moved to a new location or is subject to disturbance, major repairs or adjustments, in accordance with BS 1610 : Part 1, to ensure compliance with clauses 3 and 4 of this Part of BS 1881.

### 4.5 Means of applying the load

The machine shall apply the load to the specimen either in direct contact with the machine platens or spacing blocks, or with auxiliary platens interposed between each machine platen or spacing block and the specimen.

## 5 Machine platens

In order to avoid excessive platen deformation during loading, the machine platens shall be adequately supported over the area in contact with the specimens.

The platens shall be made of material which, when tested in accordance with BS 427, shall have a hardness value of at least 550HV 30. Also, the material shall not deform irreversibly when the machine is used.

The flatness tolerance (see BS 308 : Part 3) for the area of each platen in contact with the specimen or auxiliary platen shall be 0.03 mm. The contact areas of the platens shall be checked for flatness at annual intervals.

The  $R_a$  value for the surface texture of the contact area of each platen shall be between 0.4  $\mu\text{m}$  and 3.2  $\mu\text{m}$  when assessed in accordance with BS 1134 : Part 1.

**NOTE.** Roughness values of finishes produced by common manufacturing processes are given in table 1 of BS 1134 : Part 2 : 1972.

## 6 Auxiliary platens

The auxiliary platens shall be made of a material which, when tested in accordance with BS 427, shall have a hardness value of at least 550HV 30. Also, the material shall not deform irreversibly when the machine is used.

The distance between either pair of opposite edges of a square auxiliary platen, or the diameter of a circular platen, shall be the nominal size of the specimen (i.e. 100 mm or 150 mm)  $+0.2$  mm; the distance between the contact faces of the platen shall be at least 23 mm.

The flatness tolerance (see BS 308 : Part 3) for each contact face of the platens shall be 0.03  $\mu$ m.

The contact faces of the auxiliary platens shall be checked for flatness at annual intervals. If auxiliary platens, worn by direct contact with the test specimens, are resurfaced they shall then be checked for size, squareness, parallelism, flatness, surface texture and hardness to ensure compliance with this clause. If case hardened auxiliary platens are resurfaced they shall be re-hardened and checked for hardness before checking for the dimensional requirements of this clause.

The squareness tolerance (squareness 4 in table 9 of BS 308 : Part 3 : 1972) for each edge of the auxiliary platen with respect to the adjacent edge as datum shall be 0.2 mm.

The parallelism tolerance (parallelism 4 in table 8 of BS 308 : Part 3 : 1972) for one contact face of the auxiliary platen with respect to the other contact face as datum shall be 0.06 mm.

The  $R_a$  value for the surface texture of the contact faces of the auxiliary platen shall be between 0.4  $\mu$ m and 3.2  $\mu$ m when assessed in accordance with BS 1134 : Part 1.

NOTE. Roughness values of finishes produced by common manufacturing processes are given in table 1 of BS 1134 : Part 2 : 1972.

## 7 Spacing blocks

If it is required to reduce the distance between the machine platens, up to four spacing blocks shall be located either beneath or upon the lower machine platen. Spacing blocks shall be either circular or square in section and shall comply with the flatness and parallelism tolerances required for auxiliary platens (see clause 6).

Spacing blocks shall be positively located in the horizontal plane. The accuracy of their location and of the method of specimen location (see clause 8) shall be such that the maximum distance between the axis of a located specimen and the axis of a correctly located proving device (see A.1) is less than 1.0 mm.

Spacing blocks used

- (a) beneath the lower machine platen shall be nominally 220 mm in diameter or, if square, at least 210 mm x 210 mm;

- (b) upon the lower machine platen shall be at least as large as any auxiliary platen to be used and shall not be larger than the machine platen or less than 23 mm thick;
- (c) upon the lower machine platen and in contact with concrete specimens or proving devices shall be made of a material which, when tested in accordance with BS 427, shall have a hardness value of at least 550HV 30 and which will not deform irreversibly when the machine is used. They shall have an  $R_a$  value for the surface texture of the contact faces of between 0.4  $\mu$ m and 3.2  $\mu$ m when assessed in accordance with BS 1134 : Part 1 (see note to clause 6). The contact faces of these spacing blocks shall be checked for flatness at annual intervals.

## 8 Location of specimen

Provision shall be made for positive and accurate location in the horizontal plane of the specimen or auxiliary platen on the lower machine platen or spacing block. Positive location shall be provided by the use of pegs, jigs or dowelled joints. Visual location alone is unacceptable.

## 9 Performance

### 9.1 Requirements and verification

When testing concrete cubes or vertical cylinders in compression:

- (a) the component parts of the machine shall be aligned accurately;
- (b) the upper machine platen shall align freely with the upper face of a correctly located specimen or upper auxiliary platen as initial contact is made: and
- (c) the upper machine platen shall then be restrained from tilting with respect to the lower machine platen during loading.

Compliance with these requirements shall be checked on initial commissioning, after subsequent relocation or disturbance, and at annual intervals by either:

- (1) meeting the compliance requirements of A.3, A.4 and A.6 when the machine is assessed using the proving device and procedure given in appendix A: or
- (2) meeting the compliance requirements of the British Calibration Service publication 0407, 'Supplementary criteria for laboratory approval for comparative concrete cube testing', January 1981\* .

In the event of a dispute, compliance with the requirements in (a), (b) and (c) shall be checked by using the proving device and procedure given in appendix A.

\*It is intended that this method of test will be published, in due course, as BS 1881 'Testing concrete' Part 127 'Method for verifying the performance of compressive testing machines for concrete by comparative cube testing'.

### **9.2 Record of machine performance**

**A** record shall be kept giving the following details of the machine:

- (a) machine identification;
- (b) date of purchase;
- (c) date(s) of installation or re-installation;
- (d) dates of any maintenance; detailed notes should be kept of any maintenance that could affect the performance of the machine;
- (e) dates, methods and results of verification of the performance of the machine.

## Appendix

### Appendix A. Proving device and proving procedure for concrete cube compression testing machines

NOTE. These procedures are expected to be carried out by experts. They are included to give a standard form of proving device and procedure for those laboratories qualified to conduct the test.

#### A.1 The proving device

The proving device shall be a cylinder of steel 826M40, condition W, of BS 970 : Part 1. It shall be  $100 \pm 1$  mm in diameter and  $200 \pm 1$  mm high. The flatness tolerance (see BS 308 : Part 3) for the ends, shall be 0.03 mm but the surfaces shall not be convex. The parallelism tolerance (parallelism 4 in table 8 of BS 308 : Part 3 : 1972) shall be 0.06 mm. The squareness tolerance (see BS 308 : Part 3) of the cylinder with respect to one end as datum face shall be 0.03 mm. The roundness tolerance (b in table 4 of BS 308 : Part 3 : 1972) of the ends of the cylinder shall be 0.02 mm, and the whole cylinder shall be within a cylindricity tolerance of 0.04 mm (see BS 308 : Part 3). Centre holes of maximum size 15 mm diameter by 15 mm deep are permitted in the ends of the cylinder.

The device shall be gauged using matched temperature-compensated electrical resistance strain gauges. Four

complete bridges, each centred at one of the ends of a pair of orthogonal diameters half way up the cylinder shall be used. Each bridge shall consist of two elements measuring axial strain and two measuring circumferential strain as shown in figure 1. Each bridge shall be electrically and thermally balanced.

The device shall be supported in a carrying box by circumferential shoulders near the ends of the cylinder. The edge of each shoulder nearest the centre of the cylinder shall be not further than 15 mm from the nearest end of the cylinder. Vertical lines shall be inscribed on the cylinder walls so that they are visible outside the carrying case to indicate the position of the centre lines of the bridges. These lines shall not extend further than 20 mm from the lower end of the cylinder.

The device shall be used with a switch and balance unit which enables the outputs of each of the four bridges to be balanced in the unloaded condition and the bridge outputs to be selected thereafter by operation of a switch.

NOTE. Alternatively, simultaneous display of the four bridge outputs may be used if means are provided to enable the sensitivity of the four channels to be checked and, if necessary, equalized immediately prior to the taking of a series of readings.

The maximum limit of error for the strain-measuring equipment shall be  $\pm 0.1$  % or 5 microstrain, whichever is greater.

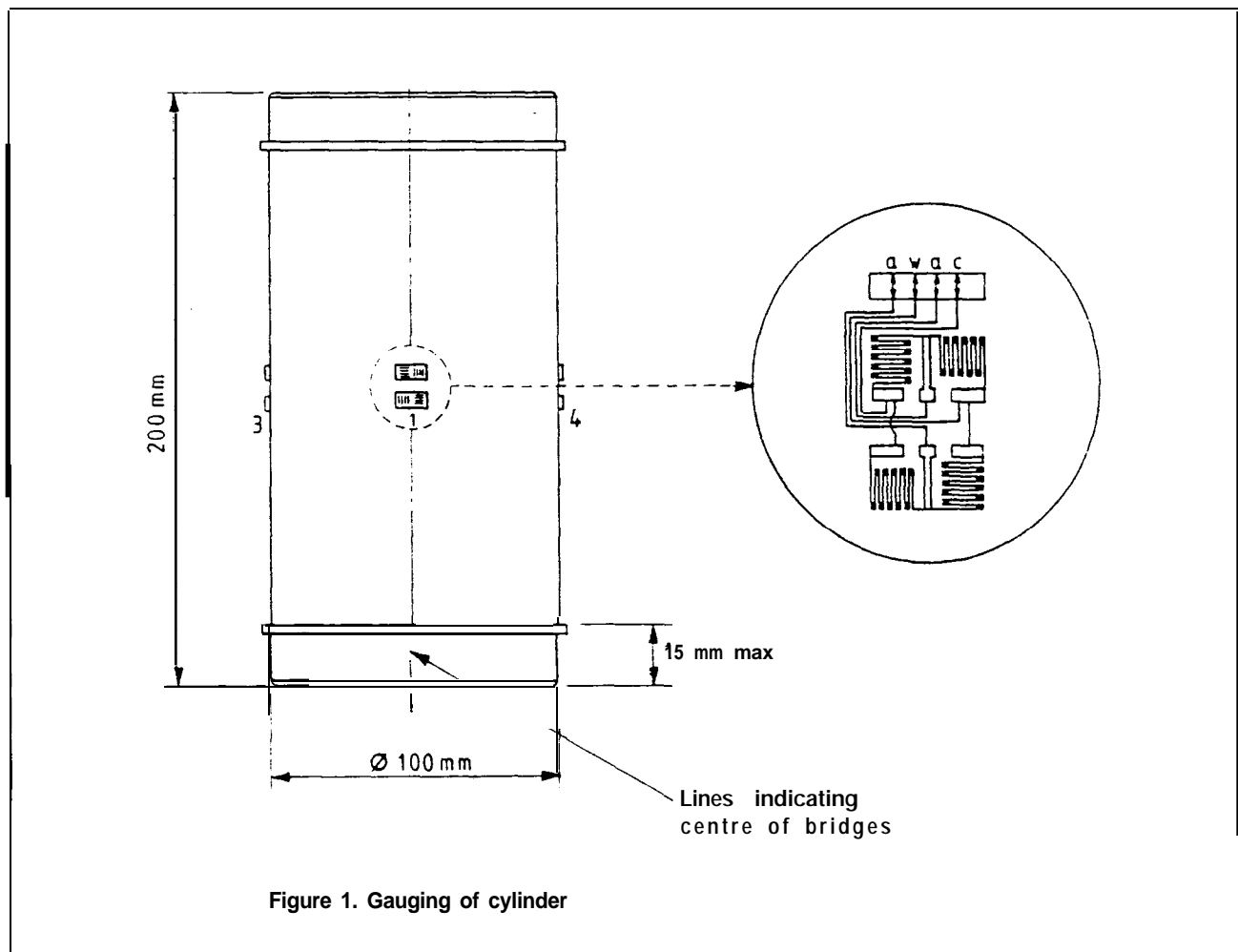

## A.2 Procedure for proving the self-alignment of the upper machine platen and the machine component parts

Locate a 150 mm square auxiliary platen which complies with clause 6 and is not convex, on the lower machine platen or spacing block and place the device centrally on it. Designating the mid-points of the edges of the auxiliary platen by A, B, C and D and the four bridge positions on the device by 1, 2, 3 and 4, position the device by eye as shown in figure 2.

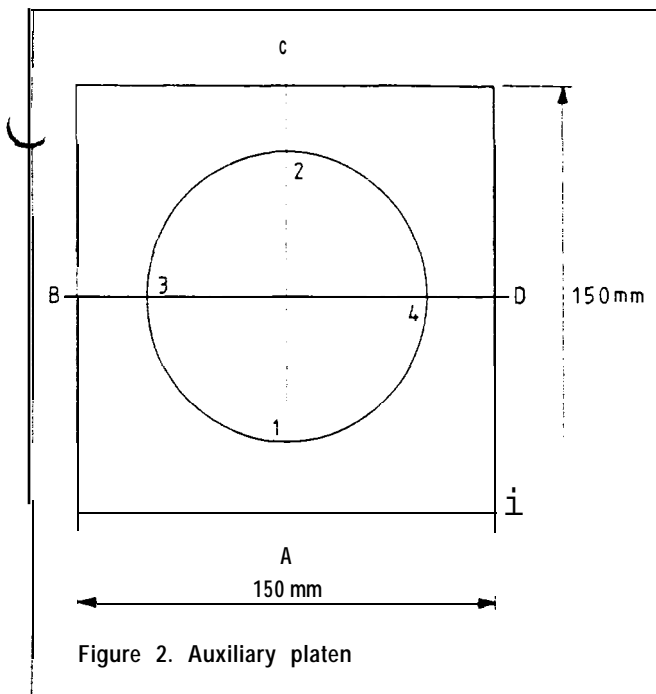

Figure 2. Auxiliary platen

Measure the distances from the centre of each top edge of the lower auxiliary platen to the nearest point on the bottom edge of the device and adjust the position of the device until the differences between pairs of measurements from opposite edges of the platen to the device do not exceed 0.10 mm.

**NOTE.** This may be conveniently achieved by fitting a stop to the edge of the platen and providing accurately machined spacers to centralize the device.

Operate the machine to bring the top of the device no closer than 5 mm to the upper machine platen and tilt the upper machine platen down towards A about axis BD either to its fullest extent or until it touches the device. Gently release the upper machine platen and operate the machine so that the upper machine platen aligns with the device. Increase smoothly the indicated load onto the device up to a nominal value of at least 200 kN. Hold the load constant and read the outputs of the four bridges. If the load exceeds 200 kN but does not exceed 220 kN before it can be held constant, do not reduce it before taking the readings. If the load exceeds 220 kN restart the test.

Use the mean  $e_m$  of the four bridge outputs  $e_1$ ,  $e_2$ ,  $e_3$  and  $e_4$  to calculate the strain ratio  $(e_n - e_m)/e_m$  for each bridge, where  $e_n$  is the strain at the bridge position under consideration.

Repeat the test; firstly with the upper machine platen tilted down towards C about an axis BD, secondly with the upper machine platen tilted down towards B about an axis AC and thirdly with the upper machine platen tilted down towards D about an axis AC.

If the device is correctly machined and gauged, the sensitivity of the four bridges will be equal. However, if this is in doubt, repeat the readings, first with bridge 1 adjacent to B, then with bridge 1 adjacent to C and finally with bridge 1 adjacent to D (see figure 2).

The readings so obtained, together with those obtained with bridge 1 opposite A, should be averaged to eliminate differences in bridge sensitivity on the device. This should be done for the readings on all four bridges.

## A.3 Self-alignment of the upper machine platen

Obtain the strain ratios at 200 kN for the four different directions of initial platen tilt and compare them. The difference between the highest and lowest values for any bridge shall not exceed 0.10.

## A.4 Alignment of the component parts of the machine

If the self-alignment is correct (see A.3), calculate the mean strain ratios for each of the four bridges. For each bridge this value shall lie within the range  $\pm 0.10$ .

## A.5 Procedure for proving restraint on movement of the upper platen

If the self-alignment and alignment are correct (see A.3 and A.4) displace the device by  $6 \pm 0.05$  mm from the central position along AC towards A. Without further adjustment of the upper machine platen, operate the machine to bring the device into contact with it and apply the load smoothly. Record the outputs of the four bridges at nominal loads of 200 kN and 2000 kN. If the machine capacity is less than 2000 kN, take readings at 200 kN and at maximum capacity. Take care to ensure that the output of each of the four bridges is read while the load is held constant. If either nominal load is exceeded, but not by more than 10 %, before it can be held constant do not reduce it before taking the readings. If either nominal load is exceeded by more than 10 %, restart the test.

Repeat these readings with the device, displaced  $6 \pm 0.05$  mm from the central position; firstly along AC towards C, secondly along BD towards B and thirdly



along BD towards D. Calculate the change in strain ratio per mm offset (1) for displacement along AC, (2) for displacement along BD for each load. If  $r_1$ ,  $r_2$ ,  $r_3$  and  $r_4$  represent strain ratios for bridges at positions A, C, B and D and  $a$ ,  $c$ ,  $b$  and  $d$  denote ratios for displacement towards A, C, B and D, respectively then for each load the value for displacement along AC is calculated as:

$$\frac{(r_1c - r_2c) - (r_1a - r_2a)}{24}$$

(1)

and for displacement along BD as:

$$\frac{(r_3d - r_4) - (r_3b - r_4)}{24} \quad (2)$$

#### A.6 Restraint on tilt of the upper platen

The change in strain ratio per mm offset in each of the two directions shall not exceed 0.06 at 200 kN or 0.04 at 2000 kN or at the maximum capacity of the machine if this is less than 2000 kN.

## **Publications referred to**

- BS 308 Engineering drawing practice  
Part 3 Geometrical tolerancing
- BS 427 Method for Vickers hardness test
- BS 970 Wrought steels for mechanical and allied engineering purposes  
Part 1 General inspection and testing procedures and specific requirements for carbon, carbon manganese, alloy and stainless steels
- BS 1134 Method for the assessment of surface texture  
Part 1 Method and instrumentation  
Part 2 General information *and* guidance
- BS 1610 Materials testing machines and force verification equipment  
Part 1 Specification for the grading of the forces applied by materials testing machines  
Part 2 Specification for the grading of equipment used for the verification of the forces applied by materials testing machines
- BS 3693 Recommendations for the design of scales and indexes  
Part 2 Indicating instruments to be read to 0.33 -1.25 per cent resolution
- BS 5328 Methods for specifying concrete, including ready-mixed concrete
- British Calibration Service publication 0407 'Supplementary criteria for laboratory approval for comparative concrete cube testing,  
January 1981

# BS 1881 : Part 115 : 1986

This British Standard, having been prepared under the direction of the Cement, Gypsum, Aggregates and Quarry Products Standards Committee, was published under the authority of the Board of BSI and comes into effect on 31 January 1986.

© British Standards Institution, 1986

First published January 1983

First revision January 1986

ISBN 0 580 14841 6

British Standards Institution

Incorporated by Royal Charter, BSI is the independent national body for the preparation of British Standards. It is the UK member of the International Organization for Standardization and UK sponsor of the British National Committee of the International Electrotechnical Commission.

Copyright

Users of British Standards are reminded that copyright subsists in all BSI publications. No part of this publication may be reproduced in any form without the prior permission in writing of BSI. This does not preclude the free use, in the course of implementing the standard, of necessary details such as symbols and size, type or grade designations. Enquiries should be addressed to the

Publications Manager, British Standards Institution, Linford Wood, Milton Keynes MK14 6LE. The number for telephone enquiries is 0908 320033 and for telex 825777.

Contract requirements

A British Standard does not purport to include all the necessary provisions of a contract. Users of British Standards are responsible for their correct application.

Revision of British Standards

British Standards are revised, when necessary, by the issue either of amendments or of revised editions. It is important that users of British Standards should ascertain that they are in possession of the latest amendments or editions. Information on all BSI publications is in the *BSI Catalogue*, supplemented each month by *BSI News* which is available to subscribing members of the Institution and gives details of new publications, revisions, amendments and withdrawn standards. Any person who, when making use of a British Standard, encounters an inaccuracy or ambiguity, is requested to notify BSI without delay in order that the matter may be investigated and appropriate action taken.

The following BSI references relate to the work on this standard: Committee reference CAB/4 Draft for comment 84/14810 DC

## Committees responsible for this British Standard

The preparation of this British Standard was entrusted by the Cement, Gypsum, Aggregates and Quarry Products Standards Committee (CAB/-) to Technical Committee CAB/4 upon which the following bodies were represented:

Association of Lightweight Aggregate Manufacturers  
Association of Metropolitan Authorities  
British Aggregate Construction Materials Industries  
British Civil Engineering Test Equipment Manufacturers' Association  
British Precast Concrete Federation  
British Ready Mixed Concrete Association  
Building Employers' Confederation  
Cement Admixtures Association  
Cement and Concrete Association  
Cement Makers' Federation  
Concrete Society  
County Surveyors' Society

Department of the Environment (Building Research Establishment)  
Department of the Environment (Property Services Agency)  
Department of Transport (Highways)  
Department of Transport (Transport and Road Research Laboratory)  
Electricity Supply Industry in England and Wales  
Federation of Civil Engineering Contractors  
Greater London Council  
Institute of Concrete Technology  
Institution of Civil Engineers  
Institution of Highways and Transportation  
Institution of Structural Engineers  
Institution of Water Engineers and Scientists  
Royal Institute of British Architects  
Royal Institution of Chartered Surveyors  
Sand and Gravel Association  
Society of Chemical Industry

## Amendments issued since publication

Amd. No.	Date of issue	Text affected

British Standards Institution . 2 Park Street London W1A 2BS . Telephone 01-629 9000 • Telex 266933