British Standard

Testing concrete

**Part 118. Method for determination
of flexural strength**

Essais du béton

Partie 118. Méthode de détermination de la résistance à la flexion

Prüfverfahren für Beton

Teil 118. Bestimmung der Biegefestigkeit

BSI

Contents

	Page		Page
Foreword	Inside front cover	4. Test specimens	1
Cooperating organizations	Back cover	5. Procedure	2
Method		6. Calculation and expression of results	3
1. Scope	1	7. Test report	3
2. Definitions	1	Figure	
3. Apparatus	1	1. Arrangement of loading of test piece (two-point loading)	2

Foreword

This Part of this standard, prepared under the direction of the Cement, Gypsum, Aggregates and Quarry Products Standards Committee, is a revision of clauses 4 and 5 of BS 1881 : Part 4 : 1970. Together with Parts 115, 116, 117, 119 and 120, this Part of BS 1881 supersedes BS 1881 : Part 4 : 1970, which is withdrawn.

The flexural strength test of beams incorporates ISO 4013 published by the International Organization for Standardization (ISO) with additional requirements for the testing machines, for the preparation of sawn beams

and in the procedure. The single, centre-point load method of test in ISO 4013 has been omitted as, in the UK, the two-point loading (third-point loading) is normally used and is preferred.

No estimate is given for repeatability or reproducibility in this Part of this British Standard. Reference should be made to BS 5497 : Part 1 for further information on the determination of repeatability and reproducibility. Compliance with a British Standard does not of itself confer immunity from legal obligations.



Amendment No. 1
published and effective from 31 July 1989
to BS 1881 : Part 118 : 1983

Testing concrete
Part 118. Method for determination
of flexural strength

Revised text

AMD 6095
July 1989

Clause 3.4.2

In line 1 delete the first sentence and substitute 'The machine grading shall comply with BS 1610 : Part 1.'

In line 5 delete 'for grade A or grade B respectively'.

AMD 6095
July 1989

Clause 3.4.3

In line 2 after 'BS 1610' insert ' : Part 1'.

AMD 6095
July 1989

Clause 3.5 Load verification

In line 2 delete 'method 3 of BS 1610' and substitute 'BS 1610 : Part 1'.

AMD 6095
July 1989

Publications referred to

Delete the entry for BS 1610 and substitute the following.

'BS 1610 Materials testing machines end force verification equipment
Part 1 Specification for the grading of the forces applied by materials testing machines'

blank



TESTING CONCRETE

SUMMARY OF PUBLISHED BRITISH STANDARDS

Due to the present restructuring of BS 1881 Methods of testing concrete and BS 4408 Recommendations for non-destructive methods of test for concrete, the following information has been published, to help keep readers up-to-date, with the situation so far. (February 1983).

BS 1881 : Part 1 : 1970	Method of sampling fresh concrete on site Method of mixing and sampling fresh concrete in the laboratory
BS 1881 : Part 2 : 1970	Slump test Compacting factor test 'V-B consistometer' test Method for determination of weight per cubic metre of fresh concrete Method for determination of air content of fresh concrete Analysis of fresh concrete
BS 1881 : Part 3 : 1970	Making and curing test cubes Making and curing no-fines test cubes Making and curing test beams Making and curing test cylinders Method for accelerating the curing of test specimens: 1) the 55°C method 2) the 82°C method
BS 1881 : Part 5 : 1970	Method for determination of the dynamic modulus of elasticity by an electrodynamic method Method for determination of changes in length of concrete prisms (initial drying shrinkage, drying shrinkage and wetting expansion) Method for determination of initial surface absorption
BS 1881 : Part 6 : 1971	Analysis of hardened concrete
BS 1881 : Part 114 : 1983	Method for determination of density of hardened concrete
BS 1881 : Part 115 : 1983	Specification for compression testing machines for concrete
BS 1881 : Part 116 : 1983	Method for determination of compressive strength of concrete cubes
BS 1881 : Part 117 : 1983	Method for determination of tensile splitting strength
BS 1881 : Part 118 : 1983	Method for determination of flexural strength
BS 1881 : Part 119 : 1983	Method for determination of compressive strength using portions of beams broken in flexure (equivalent cube method)
BS 1881 : Part 120 : 1983	Method for determination of the compressive strength of concrete cones
BS 1881 : Part 121 : 1983	Method for determination of static modulus of elasticity in compression
BS 1881 : Part 122 : 1983	Method for determination of water absorption
BS 4408 : Part 1 : 1969	Electromagnetic cover measuring devices
BS 4408 : Part 2 : 1969	Strain gauges for concrete investigations
BS 4408 : Part 3 : 1970	Gamma radiography of concrete
BS 4408 : Part 4 : 1971	Surface hardness methods of testing concrete
BS 4408 : Part 5 : 1974	Measurement of the velocity of ultrasonic pulses in concrete.

S

blank

British Standard

Testing concrete

Part 118. Method for determination of flexural strength

1. scope

This Part of this British Standard describes a method for the determination of the flexural strength of test specimens of hardened concrete by means of a constant moment in the centre zone using a two-point (or third-point) loading.

NOTE. The titles of the publications referred to in this Part of this standard are listed on the inside back cover.

2. Definitions

For the purposes of this Part of this British Standard the definitions given in BS 5328 apply.

3. Apparatus

3.1 General. The test shall be carried out using any reliable machine of sufficient capacity and capable of applying the loads continuously and vertically.

The device for applying the loads shall consist of two supporting rollers and two load-applying rollers (see figure 1).

NOTE. Although the test method describes a method of loading above the specimen on two inner rollers, the load can be applied by the supporting rollers. Also the upper and lower roller positions relative to each other may be reversed.

All rollers shall be manufactured from steel and shall have a circular cross-section with a diameter of 20 mm to 40 mm; they shall be at least 10 mm longer than the width of the test specimen.

All rollers except one shall be capable of rotating around their axes and of being inclined in a plane normal to the longitudinal axis of the test specimen.

The distance / between the outer rollers (i.e. the span) shall be equal to $3d$. The distance between the inner rollers shall be equal to d . The inner rollers shall be equally spaced between the outer rollers as shown in figure 1. All rollers shall be adjusted in their correct position with all distances having an accuracy of ± 1.0 mm.

3.2 Load control. The machine shall be capable of applying the load uniformly without shock using manual or automatic control at the rate given in clause 5 and in accordance with 3.3 to 3.5.

3.3 Load pacers. If the machine is not equipped with a device to maintain, automatically, the specified rate of increase of load on the specimen, a load pacer shall be fitted to enable the operator to manipulate the machine controls to maintain the specified rate.

If the pacer has a scale, this scale shall be basically linear such that 1 mm represents not more than 100 N/s.

Over the operating range of the scale the accuracy shall be within ± 5 %.

NOTE. The pacer may incorporate a scale with an indicator point, or, alternatively, it may be, for example, a marked disc or pointer which rotates at the rate at which the load pointer should move on the load scales being used.

If the pacer is fitted with a variable speed control or has pre-set speeds, then once the variable speed control has been set, or a pre-set speed has been chosen, the pacer speed shall remain within ± 5 % of the specified speed over the operating range.

3.4 Load scale indicators or digital displays

3.4.1 The machine shall be provided with either:

- (a) easily read dials or scales which comply with BS 3693 : Part 2; or
- (b) electrical load indicators, which shall include a visual display.

If electrical load indicators are supplemented by recording devices, e.g. punched tape or print-out recorders, these shall comply with the calibration requirements of BS 1610.

3.4.2 The machine shall be grade A or B of BS 1610. The machine scale range shall be chosen so that the specimens can be expected to fracture in that part of the range which is certified to be accurate to ± 1 % or ± 2 % of the indicated load for grade A or B respectively (i.e. normally the upper four-fifths of the range).

NOTE. Machines accurate to ± 1 % are preferred.

3.4.3 The grading of the machine in accordance with BS 1610 shall not be affected by variations in mains supply voltage or frequency of ± 10 % from the nominal value to the machine

NOTE. Where electrical or other interference exists, this may affect the accuracy of load indication, and special provisions to overcome this interference may be necessary.

3.4.4 The dial, scale or display shall have a resettable device which permits the recording of the maximum load sustained by the concrete specimen.

3.5 Load verification. The machine dials, scales or displays shall be verified in accordance with method 3 of BS 1610.

4. Test specimens

4.1 General. Test specimens shall be moulded concrete beams made, cured and stored in accordance with the relevant Parts of this standard, or sawn specimens of nominal depth d of 100 mm or 150 mm with a square cross-section and overall length of between $4d$ and $5d$. The ratio of d to the maximum size of aggregate shall be not less than three,

NOTE. The preferred size of test specimen is 150 mm x 150 mm x 750 mm long.

4.2 Preparation. Saw the specimens to the required dimensions by parallel saw cuts to full depth, to the tolerances given in 4.4. Grind flat any protruberances at the positions where the rollers make contact. On completion of these operations mark the specimen for later identification and submerge it in water at a temperature of 20 ± 2 °C for at least 48 h before testing.

4.3 Measurement of dimensions. Check nominal dimensions and take measured dimensions of each specimen in accordance with BS 1881 : Part 114.

4.4 Tolerances. Check each prepared specimen to ensure that it is accurate within the following limits.

(a) *Actual dimensions.* The actual dimensions d_1 and d_2 (see figure 1) shall be within $d \pm 1$ %.

NOTE. This tolerance should be considered in conjunction with those for flatness, squareness and parallelism.

(b) *Flatness.* The flatness tolerance (see BS 308 : Part 3) for the bearing surfaces at the 4 positions where the rollers of the testing machine make contact with the specimen shall be 0.25 mm wide.

(c) *Squareness.* The squareness tolerance (squareness 1 of BS 308 : Part 3) for each side face with respect to the original finished surface of the concrete as datum face shall be 2.0 mm wide.

(d) *Parallelism.* The parallelism tolerance (parallelism 4 of BS 308 : Part 3) for the bottom face with respect to the original finished surface of the concrete as datum face, and for one side face with respect to the other side face as datum face shall be 4.0 mm wide.

4.5 Mass and density. Weigh each specimen and determine the as-received or saturated density in accordance with BS 1881 : Part 114.

5. Procedure

Specimens stored in water shall be tested immediately on removal from the water whilst they are still wet. Specimens for testing at 24 h shall be tested in the moist condition. Specimens previously used for non-destructive tests shall not remain out of water for more than 15 min and shall be returned to water storage for at least 15 min before testing for flexural strength. If out of water more than 15 min the specimen shall be tested after a minimum of 12 h immersion in water.

Wipe clean the bearing surfaces of the supporting and loading rollers and wipe surface water and grit off the specimen.

Place the test specimen in the machine, correctly centred with the longitudinal axis of the specimen at right angles to the rollers. For moulded specimens, the mould-filling direction shall be normal to the direction of loading (see figure 1). Place sawn specimens in the machine so that the original finished surface is in tension. The original surface may not therefore be orientated with its position in the structure.

NOTE. If an alternative position is required, the fact that preliminary stress may be present in the surfaces due to sawing should be realized.

Do not use packing between the specimen and the rollers. Do not begin to apply the load until all loading and supporting rollers are in even contact with the test specimen.

Apply the load steadily and without shock at such a rate as to increase the stress at a rate of 0.06 ± 0.04 N/(mm².s).

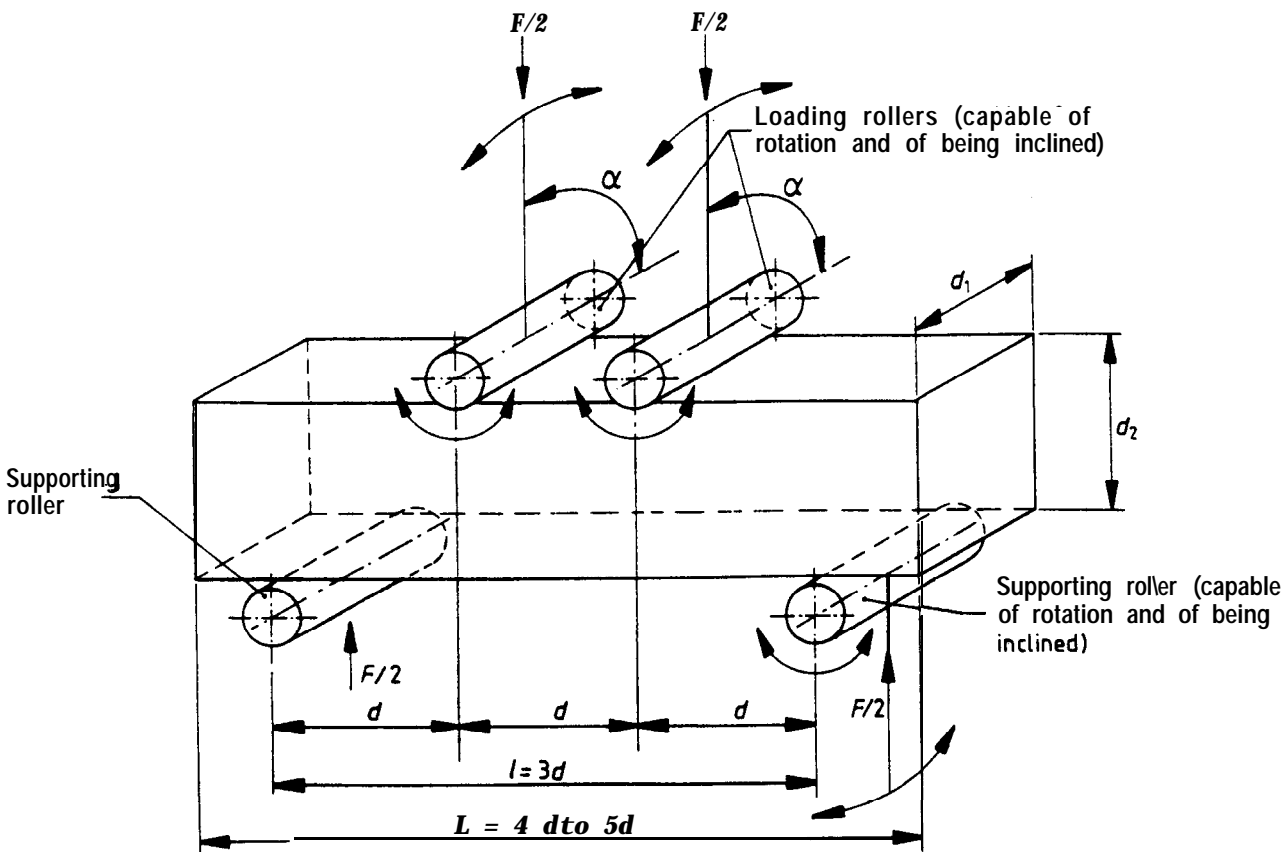

d = nominal cross-section dimension of the beam
 d_1, d_2 = actual dimensions.

Figure 1. Arrangement of loading of test piece (two-point loading)

Choose the lower loading rates for low strength concretes and the higher loading rates for high strength concretes. Once adjusted, maintain the rate of loading without change until failure occurs. Record the maximum load read on the scale as the breaking load.

NOTE. A rate of increase of stress of 0.06 N/(mm².s) is equivalent to a loading of 450 N/s for the 150 mm specimens and 200 N/s for 100 mm specimens.

Disregard failures outside the middle one-third of the distance between the supporting rollers.

6. Calculation and expression of results

The flexural strength f_{cf} (in N/mm²) is given by the equation

$$f_{cf} = \frac{F \times l}{d_1 \times d_2^2}$$

where

F is the breaking load (in N);

d_1 and d_2 are the lateral dimensions of the cross-section (in mm) (see figure 1);

l is the distance between the supporting rollers (in mm).

Express the flexural strength to the nearest 0.1 N/mm².

7. Test report

7.1 General. The report shall affirm that the tests were carried out in accordance with this Part of this standard. The report shall also state whether or not certificates of sampling, specimen preparation and curing are available. If available a copy of each certificate shall be provided.

7.2 Information to be provided by the producer of the test specimens

7.2.1 *Mandatory information.* The following information shall be provided by the producer of the test specimens for inclusion in the test report:

- (a) date, time and place of sampling and sample identity number;
- (b) time and place of making specimens;
- (c) number and nominal size of specimens;
- (d) method of compaction (hand or vibration) including type of equipment used;
- (e) identification numbers of specimens;

- (f) name of supplier of specimens;
- (g) required age of the specimens at the time of testing;
- (h) conditions of curing and storage.

7.2.2 *Optional information.* If requested the following information shall be provided by the producer of the test specimens in the test report:

- (a) name of project and place where concrete used;
- (b) name of supplier and source of concrete;
- (c) date and time of production of concrete or delivery to site;
- (d) specification of concrete mix (e.g. strength grade);
- (e) consistence of the sample;
- (f) air content of the sample (if air-entrained).

7.3 Information to be provided by the test laboratory.

The following information shall be provided by the test laboratory for inclusion in the test report:

- (a) identification of the specimen;
- (b) condition of specimen when received (include poor compaction, honeycombing or bad dimensions);
- (c) date of receipt of the specimen;
- (d) type and checked nominal or measured dimensions of the specimen;
- (e) any surface preparation;
- (f) conditions of curing or storage in the laboratory;
- (g) moisture condition at testing (saturated or moist);
- (h) date of test;
- (i) age of the specimen at the time of testing;
- (j) mass of the specimen (as-received or saturated);
- (k) density of the specimen (as-received or saturated, and the method of determining the volume);
- (l) maximum load at failure;
- (m) flexural strength;
- (n) rate of loading;
- (o) appearance of concrete and type of fracture if these are unusual;
- (p) orientation of sawn specimen to original surface;
- (q) certificate that the test has been carried out in accordance with this Part of this standard;
- (r) other remarks.

blank

Publications referred to

- BS 308 Engineering drawing practice
 Part 3 Geometrical tolerancing
- BS 1610 Methods for the load verification of testing machines
- BS 1881 Testing concrete
 Part 114 Method for determination of density of hardened concrete
- BS 3693 Recommendations for the design of scales and indexes
 Part 2 Indicating instruments to be read to 0.33- 1.25 per cent resolution
- BS 5328 Methods for specifying concrete, including ready-mixed concrete
- BS 5497* Precision of test methods
 Part 1 Guide for the determination of repeatability and reproducibility for a standard test method
- ISO 4013* Concrete – Determination of flexural strength of test specimens

*Referred to in the foreword only.



BS 1881 : Part 118 : 1983

This British Standard, having been prepared under the direction of the Cement, Gypsum, Aggregates and Quarry Products Standards Committee, was published under the authority of the Board of BSI and comes into effect on 31 January 1983.

© British Standards Institution, 1983

ISBN 0 580 12955 1

British Standards Institution incorporated by Royal Charter, BSI is the independent national body for the preparation of British Standards. It is the UK member of the International Organization for Standardization and UK sponsor of the British National Committee of the International Electrotechnical Commission.

Copyright

Users of British Standards are reminded that copyright subsists in all BSI publications. No part of this publication may be reproduced in any form without the prior permission in writing of BSI. This does not preclude the free use, in the course of implementing the standard, of necessary details such as symbols and size, type or grade designations. Enquiries should be addressed to the

Publications Manager, 101 Pentonville Road, London N1 9ND (Telephone 01-837 8801; Telex 23218).

Contract requirements

A British Standard does not purport to include all the necessary provisions of a contract. Users of British Standards are responsible for their correct application.

Revision of British Standards

British Standards are revised, when necessary, by the issue either of amendments or of revised editions. It is important that users of British Standards should ascertain that they are in possession of the latest amendments or editions. Information on all BSI publications is in the BS Yearbook, supplemented each month by *BSI News* which is available to subscribing members of the Institution and gives details of new publications, revisions, amendments and withdrawn standards. Any person who, when making use of a British Standard, encounters an inaccuracy or ambiguity, is requested to notify BSI without delay in order that the matter may be investigated and appropriate action taken.

The following BSI references relate to the work on this standard: Committee reference CAB/4 Draft for comment 80/14205 DC

Cooperating organizations

The Cement, Gypsum, Aggregates and Quarry Products Standards Committee, under whose direction this British Standard was prepared, consists of representatives from the following:

- Association of Consulting Engineers
- Association of County Councils
- Association of District Councils
- Association of Metropolitan Authorities
- Autoclaved Aerated Concrete Products Association
- *British Precast Concrete Federation Ltd.
- *British Quarrying and Slag Federation
- British Railways Board
- *British Ready Mixed Concrete Association
- British Steel Industry
- Cement Admixtures Association
- *Cement and Concrete Association
- *Cement Makers' Federation
- Chemical Industries Association
- *Concrete Society Limited
- *County Surveyors' Society
- *Department of the Environment (Building Research Establishment)
- *Department of the Environment (PSA)
- *Department of the Environment (Transport and Road Research Laboratory)
- *Department of Transport
- *Federation of Civil Engineering Contractors
- Gypsum Products Development Association

- Institute of Quarrying
- *Institution of Civil Engineers
- *Institution of Highway Engineers
- *Institution of Municipal Engineers
- Institution of Public Health Engineers
- *Institution of Structural Engineers
- *Institution of Water Engineers and Scientists
- *National Federation of Building Trades Employers
- Natural Environment Research Council (Institute of Geological Science)
- *Royal Institute of British Architects
- *Royal Institution of Chartered Surveyors
- Sand and Ballast Hauliers and Allied Trades Alliance
- *Sand and Gravel Association Limited
- *Society of Chemical Industry
- Stone Federation

The organizations marked with an asterisk in the above list, together with the following, were directly represented on the Technical Committee entrusted with the preparation of this British Standard:

- British Civil Engineering Test Equipment Manufacturers' Association
- Electricity Supply Industry in England and Wales
- Greater London Council
- Institute of Concrete Technology
- Coopted member

Amendments issued since publication

Amd. No.	Date of issue	Text affected

British Standards Institution . 2 Park Street London W1A 2BS . Telephone 01-629 9000 : Telex 266933