

Testing concrete

Part 208. Recommendations for the determination of the initial surface absorption of concrete

ICS 91.100.30

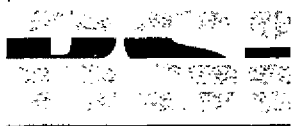

Committees responsible for this British Standard

The preparation of this British Standard was entrusted by Technical Committee B/517, Concrete, to Subcommittee B/517/1, Concrete production and testing, upon which the following bodies were represented:

Association of Lightweight Aggregate Manufacturers
 Association of Metropolitan Authorities
 British Aggregate Construction Materials Industries
 British Cement Association
 British Civil Engineering Test Equipment Manufacturers' Association
 British Precast Concrete Federation
 British Ready Mixed Concrete Association
 Building Employers' Confederation
 Cement Admixtures Association
 Cementitious Slag Makers' Association
 Concrete Society
 County Surveyors' Society
 Department of the Environment (Building Research Establishment)
 Department of the Environment
 Department of Transport (Highways Agency)
 Electricity Association
 Federation of Civil Engineering Contractors
 Federation of Piling Specialists
 Institute of Concrete Technology
 Institution of Civil Engineers
 Institution of Structural Engineers
 Institution of Water and Environmental Management
 National House-Building Council
 Quality Ash Association
 Sand and Gravel Association
 Society of Chemical Industry

This British Standard, having been prepared under the direction of the Sector Board for Building and Civil Engineering, was published under the authority of the Standards Board and comes into effect on 15 September 1996

© BSI 1996

Amendments issued since publication

Amd. No.	Date	Text affected

The following BSI references relate to the work on this standard:
 Committee reference B/517/1
 Draft for comment 95/106828 DC

ISBN 0 580 26201 4

Contents

	Page
Committees responsible	Inside front cover
Foreword	ii
Recommendations	
1 Scope	1
2 References	1
3 Definitions	1
4 Applications	1
5 Factors influencing the initial surface absorption of concrete	2
6 Apparatus	2
7 Calibration of apparatus	5
8 Procedure	5
9 Factors affecting test results	7
10 Precision	7
11 Test report	7
Tables	
1 Determination of period of movement	6
2 Correction factors to convert readings to an equivalent value at 20 °C	7
Figures	
1 Assembly of typical absorption apparatus	3
2 Typical cap suitable for clamping onto a smooth horizontal surface	4
3 Typical cap suitable for use on a vertical surface	4
List of references	Inside back cover

Foreword

This Part of BS 1881 has been prepared by Subcommittee B/517/1. It supersedes clause 6 of BS 1881 : Part 5 : 1970 which has been deleted. All aspects of testing concrete are included as Parts of BS 1881 from sampling fresh concrete to assessing concrete in structures. BS 1881 : Part 201 : 1986 *Guide to the use of non-destructive methods of test for hardened concrete* gives general guidance on the choice of non-destructive test methods and should be consulted for advice on methods which complement the measurement of initial surface absorption or are useful as alternatives.

In this Part of BS 1881, recommendations for surface absorption differ from those in clause 6 of BS 1881 : Part 5 : 1970 in the omission of the requirement for a measurement at 2 h after commencing the test since this is no longer regarded as providing useful additional information in practice. Recommendations on applications, factors influencing results and interpretation is also provided.

The method given in this standard provides a low pressure assessment of the water absorption of the concrete surface. Other tests currently under development involve higher pressures or surface drilling and the results from such tests will be governed by properties of the concrete not necessarily related to surface absorption.

Compliance with a British Standard does not of itself confer immunity from legal obligations.

Recommendations

1 Scope

This Part of BS 1881 gives recommendations for a method of determining the initial surface absorption of oven dried concrete, of concrete in the laboratory which cannot be oven dried and of site concrete. Recommendations are given on areas of application of this method and the interpretation of results.

2 References

2.1 Normative references

This Part of BS 1881 incorporates, by dated or undated reference, provisions from other publications. These normative references are made at the appropriate places in the text and the cited publications are listed on the inside back cover. For dated references, only the edition cited applies; any subsequent amendments to or revisions of the cited publication apply to this Part of BS 1881 only when incorporated in the reference by amendment or revision. For undated references, the latest edition of the cited publication applies, together with any amendments.

2.2 Informative references

This Part of BS 1881 refers to other publications that provide information or guidance. Editions of these publications current at the time of issue of this standard are listed on the inside back cover, but reference should be made to the latest editions.

3 Definitions

For the purposes of this Part of BS 1881 the definitions in BS 6100 : Part 6 : Section 6.2 apply together with the following:

3.1 location

Region of concrete that is being assessed and that, for practical purposes, is assumed to be of uniform quality.

3.2 initial surface absorption

Rate of flow of water into concrete per unit area at a stated interval from the start of the test and at a constant applied head.

3.3 surface zone

Zone of concrete immediately behind the surface.

NOTE. The thickness of the zone that influences the result of this test may range between a few millimetres and several centimetres depending on the nature and condition of the concrete.

4 Applications

4.1 General

This test method provides data for assessing the uniaxial water penetration characteristics of a concrete surface. The applied pressure of 200 mm head of water is worse than the severest weather exposure in the UK due to driving rain. The results may be considered to be related to the quality of finish and to the durability of the surface under the effects of natural weathering. The results are of little relevance to behaviour under higher water pressures, and cannot be used to assess the permeability of a body of concrete.

This test method can be applied to exposed aggregate or profiled surfaces provided that a watertight seal can be obtained with the apparatus. The test is not applicable to specimens or areas showing obvious porosity, honeycombing or cracking. Misleading results can be obtained when tests are performed on thin concrete sections through which water could penetrate during the test. Tests should not be repeated at positions within an area affected by previous tests.

4.2 Quality control

4.2.1 Precast concrete

The test is most reliably applied to precast concrete units which can be tested under standardized dry conditions. Results obtained may be compared with predetermined acceptance limits.

4.2.2 Cast stone

Details of recommended acceptance requirements for cast stone are given in BS 1217 on the basis of results obtained by this method.

4.2.3 In situ concrete

It is difficult to achieve standardized drying conditions for in situ concrete although generalized classification limits relating to surface weathering characteristics have been proposed which can be applied to in situ test results. The method has been successfully used on this basis to assess compliance with specifications for weathering performance¹⁾.

Combinations of initial surface absorption and cover to reinforcement have been proposed²⁾.

4.3 Comparability surveys

Since it is sensitive to surface finish as well as to the quality of the concrete in the surface zone, the test provides a means of comparative assessment of these characteristics. With careful interpretation, the test may usefully be applied to in situ concrete

¹⁾ *Permeability testing of site concrete — A review of methods and experience.* Concrete Society Technical Report 31

²⁾ Levitt, M. The ISAT for limit state design for durability. *Concrete*. Vol 19, No.7, p 29. July 1985.

construction.

5 Factors influencing the initial surface absorption of concrete

Guidance concerning their influence upon the interpretation of results in practical circumstances is given in clause 9. All the following factors affect the surface absorption of concrete:

- a) moisture conditions;
- b) concrete mix;
- c) aggregate;
- d) surface finish and type;
- e) curing;
- f) age of concrete;
- g) cracking (visible cracks should be avoided);
- h) water type;
- i) temperature.

Although impurities in the water can influence the rate of absorption, this effect may be disregarded provided that the water is of potable quality. However, distilled or de-ionized water shall be used for calibrating the capillary tube (see 7.2).

6 Apparatus

6.1 Test assembly, comprises a watertight cap which is sealed to the concrete surface and connected by means of flexible tubes to a reservoir and a capillary tube with a scale. A control tap is fitted to the connection between the reservoir and cap. A typical test assembly is illustrated in figure 1.

6.2 Cap, of any suitable rigid non-corrodible impermeable material providing a minimum area of water contact with the surface to be tested of 5000 mm².

NOTE. It is useful for the cap to be made of a transparent material such as a clear acrylic, polyester or epoxy resin (reinforced if necessary) as this allows the operator to observe the filling of the cap with water and the displacement of the air.

An inlet and an outlet tube are fixed into the cap, the former connecting to the reservoir and the latter to the capillary tube. The outlet is so positioned that it is at the highest part of the cap to allow all trapped air to escape.

A suitable cap for clamping onto horizontal concrete specimens with a relatively smooth surface as illustrated in figure 2. This has a soft elastomeric gasket to provide a watertight seal. It is possible for the gasket to be glued to the surface of smooth dry laboratory specimens. In cases where either the surface of the concrete is not smooth, or the cap cannot be clamped onto the surface to be tested, the cap should have a knife edge for contact with the concrete. Recommendations for fixing the cap to the test surface is given in 8.2. A suitable cap for testing vertical or sloping surfaces or soffits is illustrated in figure 3.

6.3 Connections

6.3.1 Inlet. The inlet tube to the cap is connected to the reservoir by a flexible tube of sufficient length to enable a head of water between 180 mm and 220 mm above the surface of the concrete under test to be maintained, and is fitted with a tap.

6.3.2 Outlet. The outlet tube from the cap is connected to the capillary tube by a flexible tube of sufficient length to enable the capillary tube to be set horizontally at a head of water between 180 mm and 220 mm above the surface of the concrete under test.

6.4 Reservoir, of glass or plastics material of about 100 mm diameter.

6.5 Capillary tube and scale. A length of precision bore glass capillary tubing at least 200 mm long and with a bore of 0.4 mm to 1.0 mm radius, determined as described in 7.2, is fixed to a scale calibrated by the procedure described in 7.3.

NOTE. The length of capillary tubing necessary to accommodate the full range of possible initial surface absorption values indicated in table 1 will depend upon the radius of the capillary bore and the cap size. The scale is marked in divisions as described in 7.3.

For a cap of the minimum dimensions given in 6.2, a capillary bore of 0.4 mm radius and concrete of high initial absorption, the length required would exceed 1 m. To limit the length of tube to a convenient value, a combination of cap size and capillary bore should be chosen to accommodate the range of initial surface absorptions anticipated. The more permeable the concrete, the larger the bore or the length needs to be. The capillary tube protrudes beyond one end of the scale for connection to the outlet of the cap.

6.6 Stands and clamps, to support the reservoir and capillary tube and scale, allowing for adjustments within the ranges given in 6.3.

6.7 Stop watch or clock, accurate to 0.5 s.

6.8 Measuring cylinder, of 10 ml capacity conforming to BS 604.

6.9 Thermometers, accurate to the nearest 0.2 °C, suitable for measuring the temperature of the water and of the concrete surface.

6.10 Drying oven, ventilated, in which the temperature is controlled at $(105 \pm 5) ^\circ\text{C}$.

6.11 Cooling cabinet, dry airtight vessel of sufficient capacity to contain the specimens to be tested.

6.12 Balance, of appropriate capacity to weigh the specimens to the accuracy required by 8.1.2.

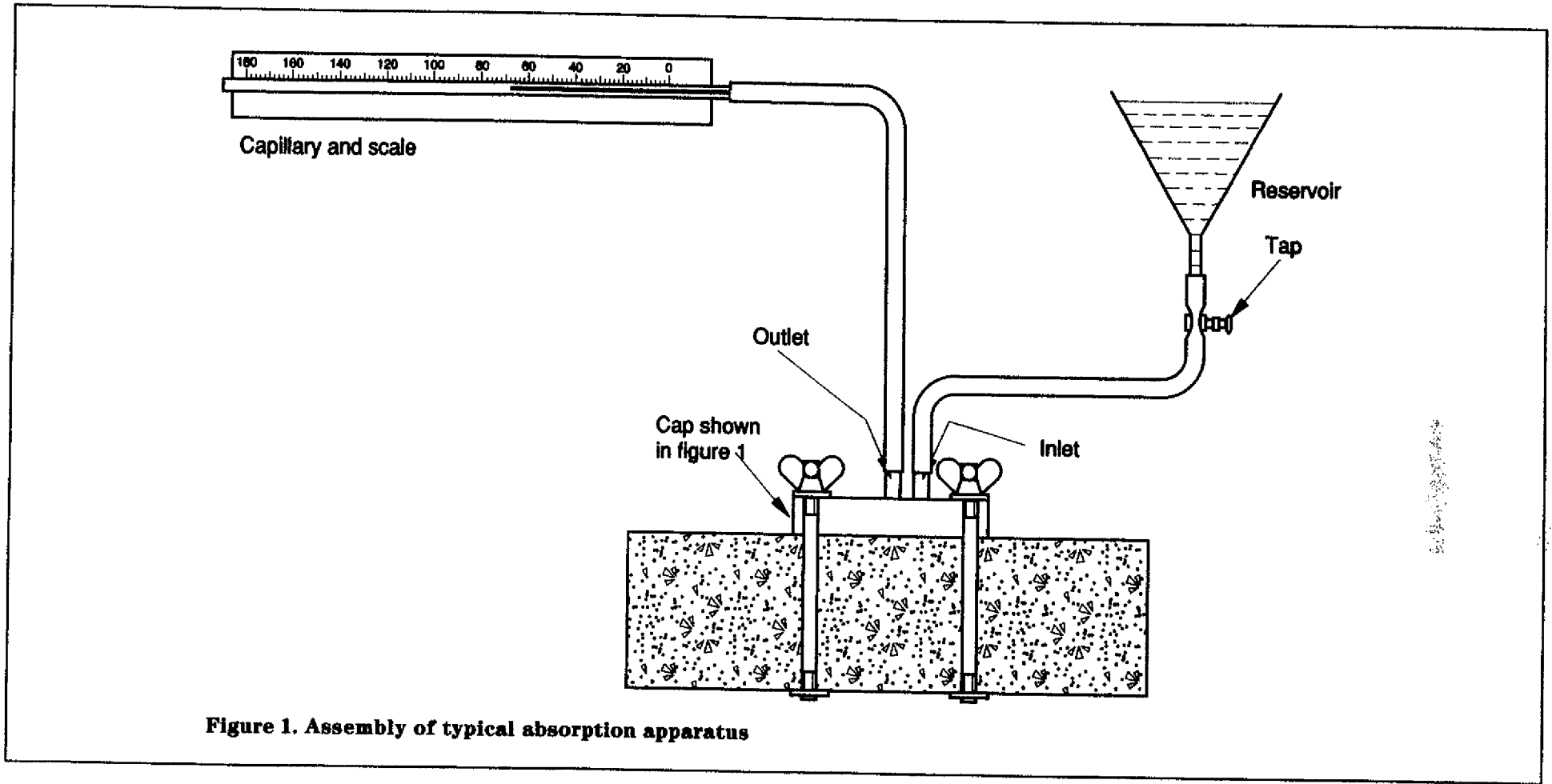
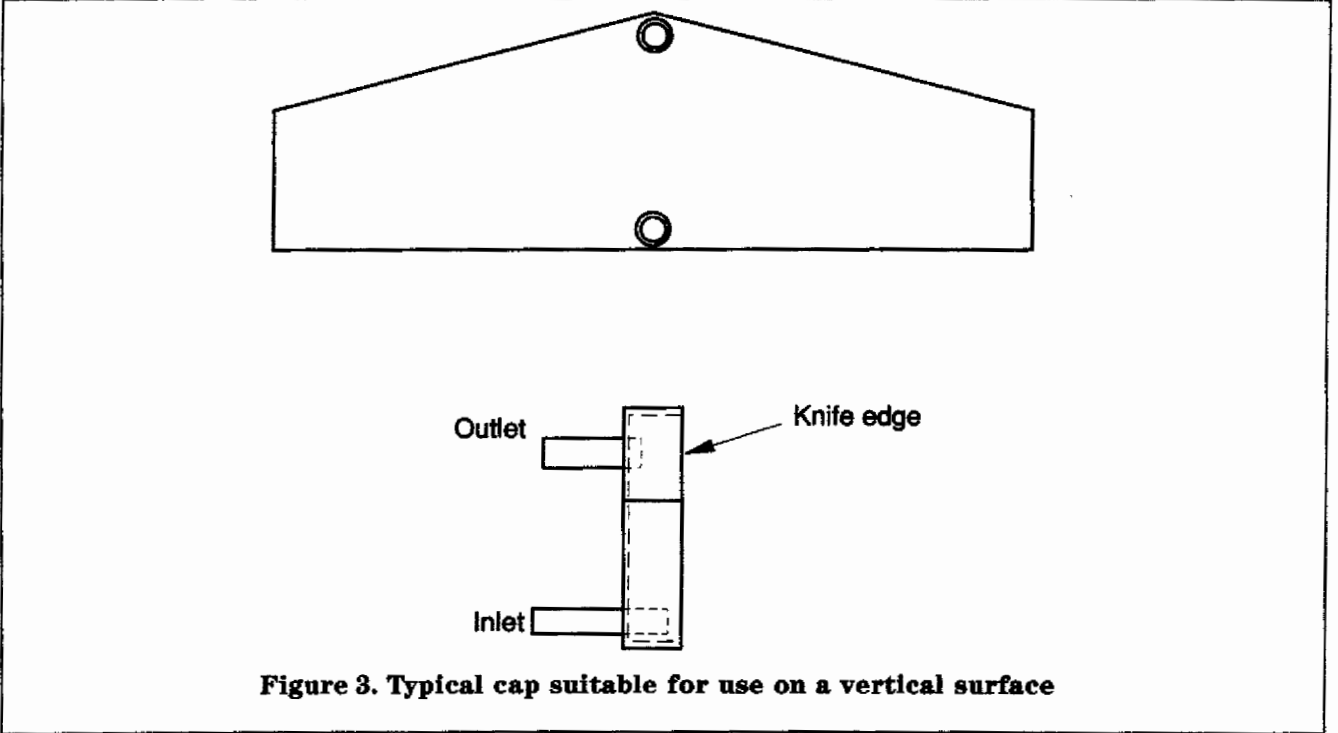
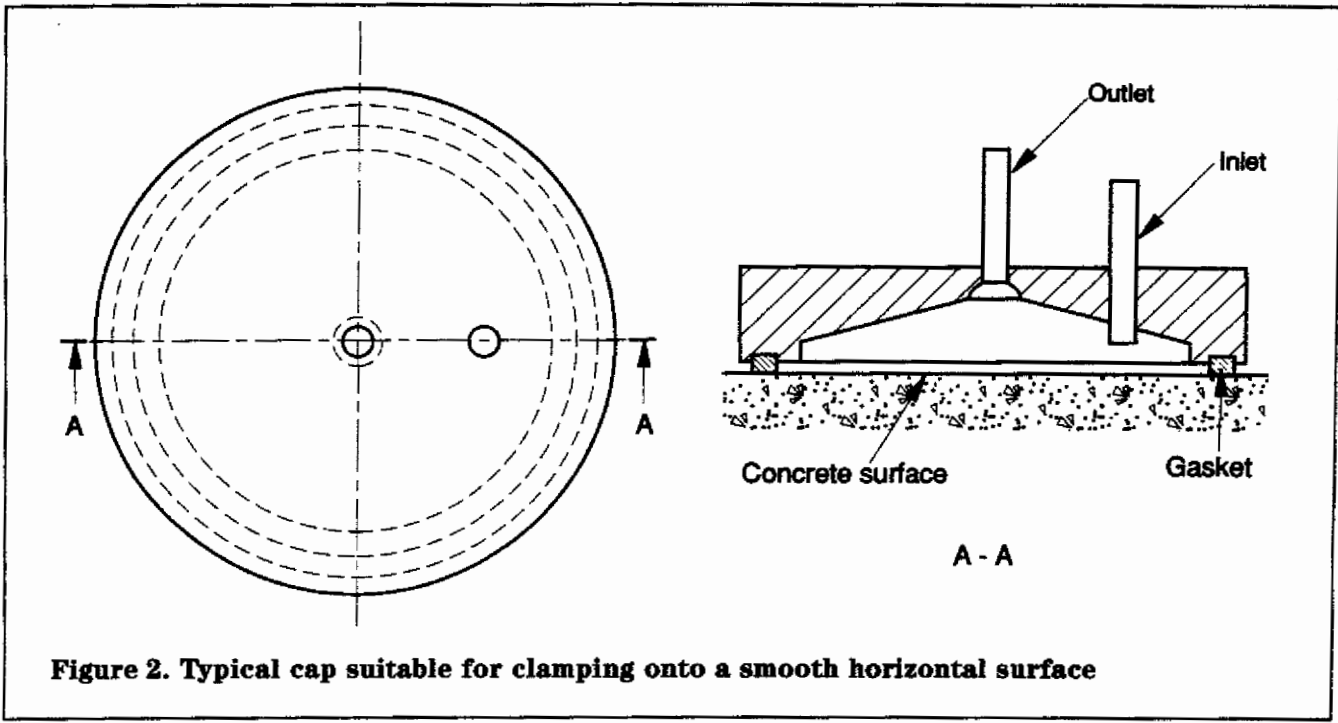

Figure 1. Assembly of typical absorption apparatus



7 Calibration of apparatus

7.1 General

The calibration of the capillary tube is arranged so that the movement of water along it during 1 min, as read directly from the scale, equals the initial surface absorption in $\text{ml}/(\text{m}^2\text{-s})$ at a constant head and temperature during the test.

7.2 Radius of bore of capillary tube

Measure the length of the capillary tube (6.5) and record it to the nearest millimetre. Flush the tube through with soap solution, followed by at least 25 ml of distilled or de-ionized water. Clamp the tube horizontally and connect it to the reservoir (6.4) by means of the flexible tube (6.3.1) fitted with a tap. Fix the reservoir such that a head of water of (200 ± 5) mm is maintained during the course of the calibration.

Close the tap and fill the reservoir with distilled or de-ionized water to the specified level. Determine the temperature of the water using the thermometer (6.9) and ensure that this is within 1°C of ambient. Open the tap and, when a steady discharge occurs, place the measuring cylinder (6.8) under the open end and begin to collect the water. Record in seconds the time required to collect 10 ml of water.

Repeat this procedure twice more and calculate the mean of the three times.

Calculate the bore radius of the capillary tube, r , in millimetres, from the following equation:

$$r^4 = \frac{KL}{t}$$

where

- L is the length of the capillary tube (in millimetres);
- t is the mean time to collect 10 ml of water (in seconds);
- K is a coefficient incorporating the viscosity of water and the geometry of the apparatus obtained from the values below using linear interpolation between adjacent values.

Water temperature ($^\circ\text{C}$):	10	15	20	25	30
Factor K :	0.0167	0.0145	0.0128	0.0114	0.0100

7.3 Capillary scale

From the dimensions of the cap, taking account of the seal geometry, calculate the area of contact of the water with the specimen, A_1 , and record this in mm^2 . Calculate the area of the bore of the capillary, A_2 , in mm^2 using the value of r calculated as described in 7.2 from:

$$A_2 = \pi r^2$$

Prepare a scale to mount behind the capillary tube marked off with at least 180 divisions, spaced $6 \times 10^{-4} A_1/A_2$ mm apart. Each such division will then represent 0.01 units of $\text{ml}/(\text{m}^2\text{-s})$.

8 Procedure

8.1 Selection and recommended preparation of specimens

8.1.1 Number of specimens

Test at least three separate specimens or locations selected to be representative of the concrete under examination and suitable for test with the cap and clamping system to be used. Areas exhibiting surface cracking should normally be avoided. Mould oil or curing membranes may affect the results as can the procedures needed to remove them.

8.1.2 Oven dried specimens

Dry the specimen in the oven (6.10) at $(105 \pm 5)^\circ\text{C}$ until constant mass is achieved, i.e. not more than 0.1 % weight change over any 24 h drying period. When the specimen has reached constant mass, place it in the cooling cabinet (6.11) and allow the temperature in the cabinet to fall to within 2°C of that of the room. Leave each specimen in the cabinet until required for testing. Concrete made with high alumina cement should not be conditioned by oven drying.

8.1.3 Non-oven dried specimens

8.1.3.1 Conditioning for laboratory testing

Allow the concrete unit or specimen to remain in the laboratory for a minimum period of 48 h at a temperature of $(20 \pm 2)^\circ\text{C}$ before testing.

8.1.3.2 Conditions for site testing

Protect the surface to be tested from water for a period of at least 48 h prior to the test. Do not allow contact between the protective material and the surface to be tested. Protect the surface from direct sunlight for at least 12 h prior to and during the test.

8.2 Fixing the cap

Slightly grease the gasket where it is made of a solid elastomer. Foamed elastomeric gaskets may or may not need greasing.

In the case of knife edged caps, form a seal round the outside of the cap to prevent any loss of water from under the knife edge. A variety of materials can be used, and should be firmly applied to the concrete and the edges of the cap to build a wall capable of withstanding the water pressure. One of the best materials is modelling clay into which enough grease can be kneaded to enable it to 'wet' glass or metal. The colour may be selected to match the concrete.

A gentle application of heat to the test surface helps to remove residual moisture and may assist in the adhesion of the sealing compound. If this procedure is adopted it should be stated in the report.

Clamp the cap into position or fix into place and test by blowing gently down one of the tubes whilst closing the other. Leakage may occur in the course of a test under site conditions due to movement of the seal and can be detected by applying a small amount of soap solution to the outside of the joint. Carefully examine the sealing of the cap throughout each test and if any signs of leakage are observed discontinue the test.

8.3 Assembling the apparatus

Set up the reservoir so that when it is filled (see 8.5) a head of 180 mm to 220 mm of water is applied to the surface of the concrete.

NOTE. For non-horizontal surfaces measure the head of water from mid-height of the concrete under the cap.

Connect the reservoir to the inlet of the cap with the flexible tubing, which has the tap fitted to it.

Support the capillary tube, calibrated as described in clause 7, horizontally just below the level of the surface of the water in the reservoir.

8.4 Temperature of water

In laboratory tests maintain the temperature of the water at $(20 \pm 2) ^\circ\text{C}$.

In site tests no limits can be laid down, but take precautions to avoid undue fluctuations in the temperature of the water during the test.

8.5 Starting the test

Measure and report the temperature of the concrete surface adjacent to the cap to the nearest $1 ^\circ\text{C}$.

Close the tap from the reservoir and fill the reservoir with water. Start the test by opening the tap to allow the water to run into the cap and record this start time. Flush all air from the cap through the capillary tube, assisted if necessary, by sharply pinching the flexible tubing. Replenish the reservoir to maintain the head of 180 mm to 220 mm of water and raise one end of the capillary tube just above the water level to prevent further outflow. Take care at all times to ensure that the reservoir does not empty itself.

8.6 Readings

Take readings normally after the following intervals from the start of the test:

- 10 min;
- 30 min; and
- 1 h.

As the test proceeds, the moisture content of the concrete will increase and capillary pores within the concrete adjacent to the test area become water filled. The rate of surface absorption will normally diminish as the duration of the test increases.

Just before the specified intervals lower the capillary tube so that water runs in to fill it completely and then fix it in a horizontal position at the same level as the surface of the water in the reservoir.

At each of the specified test intervals close the tap to allow water to flow back along the capillary tube. When the meniscus reaches the scale start the stop watch. After 5 s note the number of scale divisions the meniscus has moved and, by reference to table 1, determine the period during which movement is to be measured.

Table 1. Determination of period of movement

Number of scale divisions moved in 5 s	Period during which movement is measured
< 3	2 min
3 to 9	1 min
10 to 30	30 s
> 30	Record initial surface absorption as more than 3.60 ml/(m ² .s)

NOTE. 1 division = 0.01 unit (see 7.3).

Record the number of scale divisions moved during the period selected from table 1. When readings are taken over a 2 min or 30 s period, multiply the number of divisions by 0.5 or 2 respectively to convert the reading to a 1 min period. Record the actual or equivalent number of scale units traversed per min, which is 0.01 times the number of divisions, as the initial surface absorption in ml/(m².s) for that particular test interval. If the movement over the 5 s period exceeds 30 scale divisions record the initial surface absorption as more than 3.60 ml/(m².s).

If the reading taken 10 min after the start of the test is below 0.05 ml/(m².s), stop the test and record the result with the comment 'concrete too impermeable to be sensitive to a longer term test'. Similarly, where the 10 min reading is above 3.60 ml/(m².s), stop the test and record the result with the comment 'concrete too permeable to be within the sensitivity of the test method'.

Between test intervals leave the tap open and maintain the level of the water in the reservoir at the specified head. The capillary tube may be tilted or raised a little to prevent overflow of the water.

9 Factors affecting test results

9.1 General

Detailed interpretation of results will depend upon the purpose and circumstances of use of the test, but the factors influencing results which are described in clause 5 should be given due consideration. Interpretation can be assisted by the recommendations given in the following clauses which is based on experience of using the method in the United Kingdom.

9.2 Sensitivity to initial moisture condition of non-oven dried specimens

Experience suggests that provided the conditioning has been carried out as described in 8.1.3, then sensitivity to residual moisture is not high in relation to the influence of other factors. The effect of such moisture will decrease as the duration of the test increases.

9.3 Variability of concrete

The results reflect the variability, which may be considerable, of the condition of the surface and of concrete properties in the surface zone. Concrete subjected to site or laboratory conditioning is likely to yield more variable results than oven dried concrete. Oven drying may cause changes in the cement paste structure and can give different results from 'naturally dry' concretes.

9.4 Period of test

In some instances, such as assessment of potential weathering characteristics or protection afforded to embedded steel, broad conclusions based on results of 10 min tests may be considered adequate. However, the effects of moisture condition indicated in 9.2 should not be overlooked. When the test area has been heated (see 8.2) reliance upon 10 min values may not be justified.

9.5 Temperature of the concrete

Major variations in the surface temperature of the concrete, from the 20 °C value for which the equipment has been calibrated, are likely to influence results significantly owing to changes in viscosity of the water. The correction factors given in table 2 should be used to convert site results to an equivalent 20 °C value.

Table 2. Correction factors to convert readings to an equivalent value at 20 °C

Concrete surface temperature °C	Multiply by
5	1.5
10	1.3
15	1.1
20	1.0
25	0.9
30	0.8

10 Precision

It is not possible to give precision data as trials have not been carried out according to procedures given in this standard.

11 Test report

The following information should be included in the test report on each specimen or each location:

- a) date, time and place of test;
- b) age of concrete under test (if known);
- c) identification and description of test specimen or element;
- d) location within the element, where applicable;
- e) positions tested, where applicable (with sketches);
- f) detailed description of the surface of the concrete;
- g) orientation of the test surface (horizontal, vertical or other direction);
- h) description of the conditioning prior to test (including surface heat treatment);
- i) method of sealing the cap;
- j) area of water contact of the cap, dimensions of the cap and length of the capillary;
- k) temperature of the concrete surface;
- l) all initial surface absorption test results in ml/(m².s) as obtained in 8.6;
- m) results corrected to equivalent 20 °C values (see 9.5).

List of references (see clause 2)

Normative references

BSI publications

BRITISH STANDARDS INSTITUTION, London

BS 604 : 1982	<i>Specification for graduated glass measuring cylinders</i>
BS 1217 : 1986	<i>Specification for cast stone</i>
BS 1881	<i>Testing concrete</i>
BS 1881 : Part 201 : 1990 ¹⁾	<i>Guide to the use of non-destructive methods of test for hardened concrete</i>
BS 6100 :	<i>Glossary of building and civil engineering terms</i>
BS 6100 : Part 6	<i>Concrete and plaster</i>
BS 6100 : Part 6 : Section 6.2 : 1986	<i>Concrete</i>

Other publications

'Permeability testing of site concrete – A review of methods and experience'. Concrete Society Report, 1988.

¹⁾ Referred to in the foreword only.



5

BSI — British Standards Institution

BSI is the independent national body responsible for preparing British Standards. It presents the UK view on standards in Europe and at the international level. It is incorporated by Royal Charter.

Contract requirements

A British Standard does not purport to include all the necessary provisions of a contract. Users of British Standards are responsible for their correct application.

Revisions

British Standards are updated by amendment or revision. Users of British Standards should make sure that they possess the latest amendments or editions.

It is the constant aim of BSI to improve the quality of our products and services. We would be grateful if anyone finding an inaccuracy or ambiguity while using this British Standard would inform the Secretary of the responsible technical committee, the identity of which can be found on the inside front cover. Tel: 0181 996 9000; Fax: 0181 996 7400.

BSI offers members an individual updating service called PLUS which ensures that subscribers automatically receive the latest editions of standards.

Buying standards

Orders for all BSI, international and foreign standards publications should be addressed to Customer Services, Sales Department at Chiswick: Tel: 0181 996 7000; Fax: 0181 996 7001.

In response to orders for international standards, it is BSI policy to supply the BSI implementation of those that have been published as British Standards, unless otherwise requested.

Information on standards

BSI provides a wide range of information on national, European and international standards through its Library, the Standardline Database, the BSI Information Technology Service (BITS) and its Technical Help to Exporters Service. Contact the Information Department at Chiswick: Tel: 0181 996 7111; Fax: 0181 996 7048.

Subscribing members of BSI are kept up to date with standards developments and receive substantial discounts on the purchase price of standards. For details of these and other benefits contact Customer Services, Membership at Chiswick: Tel: 0181 996 7002; Fax: 0181 996 7001.

Copyright

Copyright subsists in all BSI publications. BSI also holds the copyright, in the UK, of the publications of the international standardization bodies. Except as permitted under the Copyright, Designs and Patents Act 1988 no extract may be reproduced, stored in a retrieval system or transmitted in any form or by any means – electronic, photocopying, recording or otherwise – without prior written permission from BSI.

This does not preclude the free use, in the course of implementing the standard, of necessary details such as symbols, and size, type or grade designations. If these details are to be used for any other purpose than implementation then the prior written permission of BSI must be obtained.

If permission is granted, the terms may include royalty payments or a licensing agreement. Details and advice can be obtained from the Copyright Manager, BSI, 389 Chiswick High Road, London W4 4AL.

MEMORANDUM

DATE:

TO:



007