

Steel, concrete and composite bridges —

Part 4: Code of practice for design of concrete bridges

UDC 624.21.01:624.012.4:624.014.2 [006.76 (083.75)]

NO COPYING WITHOUT BSI PERMISSION EXCEPT AS PERMITTED BY COPYRIGHT LAW



Committees responsible for this British Standard

The preparation of this British Standard was entrusted by the Civil Engineering and Building Structures Standards Policy Committee (CSB/-) to Technical Committee CSB/30 upon which the following bodies were represented:

Association of Consulting Engineers
 Association of County Councils
 British Constructional Steelwork Association
 British Precast Concrete Federation Ltd.
 British Railways Board
 British Steel Industry
 Cement and Concrete Association
 Concrete Society
 Constructional Steel Research and Development Organisation
 Department of the Environment (Building Research Establishment)
 Department of the Environment (Transport and Road Research Laboratory)
 Department of Transport
 Federation of Civil Engineering Contractors
 Greater London Council
 Institution of Civil Engineers
 Institution of Highways and Transportation
 Institution of Structural Engineers
 London Transport Executive
 Ministry of Defence
 Sand and Gravel Association Limited
 Scottish Development Department
 Welding Institute

The following was also represented in the drafting of the standard, through subcommittees and panels:

Coopted member

This British Standard, having been prepared under the direction of the Civil Engineering and Building Structures Standards Policy Committee, was published under the authority of the Board of BSI and comes into effect on 29 June 1990

© BSI 03-2000

First published June 1978
 Second edition June 1984
 Third edition June 1990

The following BSI references relate to the work on this standard:
 Committee reference CSB/59
 Draft for comment 88/11190 DC

ISBN 0 580 18442 0

Amendments issued since publication

Amd. No.	Date of issue	Comments

Contents

		Page
Committees responsible		Inside front cover
Foreword		x
1	Scope	1
2	Definitions and symbols	1
2.1.1	General	1
2.1.2	Partial load factors	1
2.1.3	Materials	1
2.2	Symbols	1
3	Limit state philosophy	5
3.1	General	5
3.2	Serviceability limit state	5
3.3	Ultimate limit state	5
4	Design: general	5
4.1	Limit state requirements	5
4.1.1	Serviceability limit states	5
4.1.1.1	Cracking	5
4.1.1.2	Vibration	6
4.1.1.3	Stress limitations	6
4.1.2	Ultimate limit states	6
4.1.2.1	Rupture or instability	6
4.1.2.2	Vibration	6
4.1.3	Other considerations	8
4.1.3.1	Deflections	8
4.1.3.2	Fatigue	8
4.1.3.3	Durability	8
4.2	Loads, load combinations and partial factors γ_{fL} and γ_{f3}	8
4.2.1	Loads	8
4.2.2	Serviceability limit state	8
4.2.3	Ultimate limit state	9
4.2.4	Deflection	9
4.3	Properties of materials	9
4.3.1	General	9
4.3.2	Material properties	9
4.3.2.1	Concrete	9
4.3.2.2	Reinforcement and prestressing steel	10
4.3.3	Values of γ_m	10
4.3.3.1	General	10
4.3.3.2	Serviceability limit state	10
4.3.3.3	Ultimate limit state	10
4.3.3.4	Fatigue	10
4.4	Analysis of structure	10
4.4.1	General	10
4.4.2	Analysis for serviceability limit state	10
4.4.2.1	General	10
4.4.2.2	Methods of analysis and their requirements	11
4.4.3	Analysis for ultimate limit state	11

	Page	
4.4.3.1	General	11
4.4.3.2	Methods of analysis and their requirements	11
4.5	Analysis of section	11
4.5.1	Serviceability limit state	11
4.5.2	Ultimate limit state	11
4.6	Deflection	11
4.7	Fatigue	11
4.8	Combined global and local effects	14
4.8.1	General	14
4.8.2	Analysis of structure	14
4.8.3	Analysis of section	14
5	Design and detailing: reinforced concrete	14
5.1	General	14
5.1.1	Introduction	14
5.1.2	Limit state design of reinforced concrete	14
5.1.2.1	Basis of design	14
5.1.2.2	Durability	14
5.1.2.3	Other limit states and considerations	14
5.1.3	Loads	14
5.1.4	Strength of materials	14
5.1.4.1	Definition of strengths	14
5.1.4.2	Characteristic strength of concrete	14
5.1.4.3	Characteristic strength of reinforcement	15
5.2	Structures and structural frames	15
5.2.1	Analysis of structures	15
5.2.2	Redistribution of moments	15
5.3	Beams	16
5.3.1	General	16
5.3.1.1	Effective span	16
5.3.1.2	Effective width of flanged beams	16
5.3.1.3	Slenderness limits for beams	16
5.3.2	Resistance moment of beams	16
5.3.2.1	Analysis of sections	16
5.3.2.2	Design charts	17
5.3.2.3	Design formulae	17
5.3.3	Shear resistance of beams	18
5.3.3.1	Shear stress	18
5.3.3.2	Shear reinforcement	18
5.3.3.3	Enhanced shear strength of sections close to supports	19
5.3.3.4	Bottom loaded beams	19
5.3.4	Torsion	19
5.3.4.1	General	19
5.3.4.2	Torsionless systems	19
5.3.4.3	Stresses and reinforcement	19
5.3.4.4	Treatment of various cross sections	19
5.3.4.5	Detailing	20
5.3.5	Longitudinal shear	21
5.3.6	Deflection in beams	21
5.3.7	Crack control in beams	21

	Page	
5.4	Slabs	21
5.4.1	Moments and shear forces in slabs	21
5.4.2	Resistance moments of slabs	21
5.4.3	Resistance to in-plane forces	21
5.4.4	Shear resistance of slabs	21
5.4.4.1	Shear stress in solid slabs: general	21
5.4.4.2	Shear stresses in solid slabs under concentrated loads (including wheel loads)	21
5.4.4.3	Shear in voided slabs	24
5.4.5	Deflection of slabs	24
5.4.6	Crack control in slabs	24
5.5	Columns	24
5.5.1	General	24
5.5.1.1	Definitions	24
5.5.1.2	Effective height of a column	24
5.5.1.3	Slenderness limits for columns	24
5.5.1.4	Assessment of strength	25
5.5.2	Moments and forces in columns	25
5.5.3	Short columns subject to axial load and bending about the minor axis	25
5.5.3.1	General	25
5.5.3.2	Analysis of sections	25
5.5.3.3	Design charts for rectangular and circular columns	25
5.5.3.4	Design formulae for rectangular columns	27
5.5.3.5	Simplified design formulae for rectangular columns	27
5.5.4	Short columns subject to axial load and either bending about the major axis or biaxial bending	27
5.5.5	Slender columns	28
5.5.5.1	General	28
5.5.5.2	Slender columns bent about a minor axis	28
5.5.5.3	Slender columns bent about a major axis	29
5.5.5.4	Slender columns bent about both axes	29
5.5.6	Shear resistance of columns	29
5.5.7	Crack control in columns	29
5.6	Reinforced concrete walls	29
5.6.1	General	29
5.6.1.1	Definition	29
5.6.1.2	Limits to slenderness	30
5.6.2	Forces and moments in reinforced concrete walls	30
5.6.3	Short reinforced walls resisting moments and axial forces	30
5.6.4	Slender reinforced walls	30
5.6.5	Shear resistance of reinforced walls	30
5.6.6	Deflection of reinforced walls	30
5.6.7	Crack control in reinforced walls	30
5.7	Bases	30
5.7.1	General	30
5.7.2	Moments and forces in bases	31
5.7.3	Design of bases	31
5.7.3.1	Resistance to bending	31

	Page	
5.7.3.2	Shear	31
5.7.3.3	Bond and anchorage	31
5.7.4	Deflection of bases	31
5.7.5	Crack control in bases	31
5.8	Considerations affecting design details	32
5.8.1	Constructional details	32
5.8.1.1	Sizes of members	32
5.8.1.2	Accuracy of position of reinforcement	32
5.8.1.3	Construction joints	32
5.8.1.4	Movement joints	32
5.8.2	Concrete cover to reinforcement	32
5.8.3	Reinforcement: general considerations	32
5.8.3.1	Groups of bars	32
5.8.3.2	Bar schedule dimensions	32
5.8.4	Minimum areas of reinforcement in members	33
5.8.4.1	Minimum area of main reinforcement	33
5.8.4.2	Minimum area of secondary reinforcement	33
5.8.4.3	Minimum area of links	33
5.8.5	Maximum areas of reinforcement in members	35
5.8.6	Bond anchorage and bearing	35
5.8.6.1	Geometrical classification of deformed bars	35
5.8.6.2	Local bond	35
5.8.6.3	Anchorage bond	35
5.8.6.4	Effective perimeter of a bar or group of bars	35
5.8.6.5	Anchorage of links	36
5.8.6.6	Laps and joints	36
5.8.6.7	Lap lengths	36
5.8.6.8	Hooks and bends	36
5.8.6.9	Bearing stress inside bends	36
5.8.7	Curtailement and anchorage of reinforcement	37
5.8.8	Spacing of reinforcement	37
5.8.8.1	Minimum distance between bars	37
5.8.8.2	Maximum distance between bars in tension	38
5.8.9	Shrinkage and temperature reinforcement	39
5.8.10	Arrangement of reinforcement in skew slabs	39
5.8.10.1	General	39
5.8.10.2	Solid slabs	39
5.8.10.3	Voided slabs	39
5.8.10.4	Solid composite slabs	39
5.9	Additional considerations in the use of lightweight aggregate concrete	39
5.9.1	General	39
5.9.2	Durability	40
5.9.3	Characteristic strength	40
5.9.4	Shear resistance of beams	40
5.9.5	Torsional resistance of slabs	40
5.9.6	Deflection of beams	40
5.9.7	Shear resistance of slabs	40
5.9.8	Deflection of slabs	40

	Page	
5.9.9	Columns	40
5.9.9.1	General	40
5.9.9.2	Short columns	40
5.9.9.3	Slender columns	40
5.9.10	Local bond, anchorage bond and laps	40
5.9.11	Bearing stress inside bends	41
6	Design and detailing: prestressed concrete	41
6.1	General	41
6.1.1	Introduction	41
6.1.2	Limit state design of prestressed concrete	41
6.1.2.1	Basis of design	41
6.1.2.2	Durability	41
6.1.2.3	Other limit states and considerations	41
6.1.3	Loads	41
6.1.4	Strength of materials	41
6.1.4.1	Definition of strengths	41
6.1.4.2	Characteristic strength of concrete	41
6.1.4.3	Characteristic strength of prestressing tendons	41
6.2	Structures and structural frames	42
6.2.1	Analysis of structures	42
6.2.2	Redistribution of moments	42
6.3	Beams	42
6.3.1	General	42
6.3.1.1	Definitions	42
6.3.1.2	Slender beams	42
6.3.2	Serviceability limit state: flexure	42
6.3.2.1	Section analysis	42
6.3.2.2	Concrete compressive stress limitations	43
6.3.2.3	Steel stress limitations	43
6.3.2.4	Cracking	43
6.3.3	Ultimate limit state: flexure	45
6.3.3.1	Section analysis	45
6.3.3.2	Design charts	46
6.3.3.3	Design formula	46
6.3.3.4	Non-rectangular sections	46
6.3.4	Shear resistance of beams	46
6.3.4.1	General	46
6.3.4.2	Sections uncracked in flexure	46
6.3.4.3	Sections cracked in flexure	47
6.3.4.4	Shear reinforcement	48
6.3.4.5	Maximum shear force	49
6.3.4.6	Segmental construction	49
6.3.5	Torsional resistance of beams	49
6.3.5.1	General	49
6.3.5.2	Stresses and reinforcement	49
6.3.5.3	Segmental construction	50
6.3.5.4	Other design methods	50
6.3.6	Longitudinal shear	50
6.3.7	Deflection of beams	50

	Page	
6.3.7.1	Class 1 and class 2 members	50
6.3.7.2	Class 3 members	50
6.4	Slabs	50
6.5	Columns	50
6.6	Tension members	50
6.7	Prestressing requirements	50
6.7.1	Maximum initial prestress	50
6.7.2	Loss of prestress, other than friction losses	51
6.7.2.1	General	51
6.7.2.2	Loss of prestress due to relaxation of steel	51
6.7.2.3	Loss of prestress due to elastic deformation of the concrete	51
6.7.2.4	Loss of prestress due to shrinkage of the concrete	51
6.7.2.5	Loss of prestress due to creep of the concrete	51
6.7.2.6	Loss of prestress during anchorage	52
6.7.2.7	Losses of prestress due to steam curing	52
6.7.3	Loss of prestress due to friction	52
6.7.3.1	General	52
6.7.3.2	Friction in the jack and anchorage	52
6.7.3.3	Friction in the duct due to unintentional variation from the specified profile	52
6.7.3.4	Friction in the duct due to curvature of the tendon	53
6.7.3.5	Friction in circular construction	53
6.7.3.6	Lubricants	53
6.7.4	Transmission length in pre-tensioned members	53
6.7.5	End blocks	54
6.8	Considerations affecting design details	55
6.8.1	General	55
6.8.2	Cover to prestressing tendons	55
6.8.2.1	General	55
6.8.2.2	Pre-tensioned tendons	55
6.8.2.3	Tendons in ducts	55
6.8.3	Spacing of prestressing tendons	55
6.8.3.1	General	55
6.8.3.2	Pre-tensioned tendons	55
6.8.3.3	Tendons in ducts	55
6.8.4	Longitudinal reinforcement in prestressed concrete beams	55
6.8.5	Links in prestressed concrete beams	55
6.8.6	Shock loading	56
6.8.7	Deflected tendons	56
6.8.7.1	Pre-tensioned tendons	56
6.8.7.2	Post-tensioned tendons	56
7	Design and detailing: precast, composite and plain concrete construction	56
7.1	General	56
7.1.1	Introduction	56
7.1.2	Limit state design	56
7.1.2.1	Basis of design	56
7.1.2.2	Handling stresses	56
7.1.2.3	Connections and joints	56

	Page	
7.2	Precast concrete construction	56
7.2.1	Framed structures and continuous beams	56
7.2.2	Other precast members	56
7.2.3	Supports for precast members	56
7.2.3.1	Concrete corbels	56
7.2.3.2	Width of supports for precast units	57
7.2.3.3	Bearing stresses	57
7.2.3.4	Horizontal forces or rotations at bearings	57
7.2.4	Joints between precast members	58
7.2.4.1	General	58
7.2.4.2	Halving joint	58
7.3	Structural connections between units	58
7.3.1	General	58
7.3.1.1	Structural requirements of connections	58
7.3.1.2	Design method	58
7.3.1.3	Considerations affecting design details	59
7.3.1.4	Factors affecting design and construction	59
7.3.2	Continuity of reinforcement	60
7.3.2.1	General	60
7.3.2.2	Sleeving	60
7.3.2.3	Threading	60
7.3.2.4	Welding of bars	60
7.3.3	Other types of connection	60
7.4	Composite concrete construction	60
7.4.1	General	60
7.4.2	Ultimate limit state	61
7.4.2.1	General	61
7.4.2.2	Vertical shear	61
7.4.2.3	Longitudinal shear	61
7.4.3	Serviceability limit state	62
7.4.3.1	General	62
7.4.3.2	Compression in the concrete	62
7.4.3.3	Tension in the concrete	62
7.4.3.4	Differential shrinkage	63
7.4.3.5	Continuity in composite construction	63
7.5	Plain concrete walls and abutments	64
7.5.1	General	64
7.5.2	Moments and forces in walls and abutments	64
7.5.3	Eccentricity in the plane of the wall or abutment	64
7.5.4	Eccentricity at right-angles to walls of abutments	64
7.5.5	Analysis of section	64
7.5.6	Shear	65
7.5.7	Bearing	65
7.5.8	Deflection of plain concrete walls or abutments	65
7.5.9	Shrinkage and temperature reinforcement	65
7.5.10	Stress limitations for serviceability limit state	65
Appendix A Methods of compliance with serviceability criteria by direct calculation		66
Appendix B Elastic deformation of concrete		69

	Page
Appendix C Shrinkage and creep	69
Appendix D Cover and spacing of curved tendons in ducts for prestressed concrete	75
<hr/>	
Figure 1 — Short term design stress-strain curve for normal weight concrete	12
Figure 2 — Short term design stress-strain curve for reinforcement	13
Figure 3 — Short term design stress-strain curve for normal and for low relaxation products	13
Figure 4 — <i>Figure deleted</i>	13
Figure 5 — Parameters for shear stress in solid slabs under concentrated load	23
Figure 6 — Openings in slabs	24
Figure 6a — Bearing stress	57
Figure 7 — Halving joint (diagrammatic only)	59
Figure 8 — Potential shear planes	62
Figure 9 — Coefficient k_L (environmental conditions)	70
Figure 10 — Coefficient k_m [hardening (maturity) at the age of loading]	70
Figure 11 — Coefficient k_c (composition of the concrete)	70
Figure 12 — Coefficient k_e (effective thickness)	71
Figure 13 — Coefficient k_j (variation as a function of time)	71
Figure 14 — Coefficient k_L (environment)	72
Figure 15 — Coefficient k_e (effective thickness)	72
Figure 16 — Relaxation coefficient	73
Figure 17 — Coefficient ϕ_2	74
Figure 18 — Coefficient ϕ_3	75
Figure 19 — Coefficient ϕ_4	75
<hr/>	
Table 1 — Design crack widths	7
Table 2 — Stress limitations for the serviceability limit state	8
Table 3 — Modulus of elasticity of concrete under short term loading	9
Table 4 — Values of γ_m for the serviceability stress limitations	10
Table 5 — Strength of concrete	15
Table 6 — Strength of reinforcement	15
Table 7 — Form and area of shear reinforcement in beams	18
Table 8 — Ultimate shear stress in concrete, v_c	18
Table 9 — Values of ξ_s	18
Table 10 — Ultimate torsion shear stress	21
Table 11 — Effective height, l_e , for columns	26
Table 12 — Relationship of N/N_{uz} to α_n	28
Table 13 — Nominal cover to reinforcement under particular conditions of exposure	34
Table 14 — Ultimate local bond stresses	35
Table 15 — Ultimate anchorage bond stresses	37
Table 16 — Reduction factor for effective perimeter of a group of bars	37
Table 17 — Ultimate shear stress, v_c , in lightweight aggregate concrete beams without shear reinforcement	40
Table 18 — Maximum value of shear stress in lightweight aggregate concrete beams	40
Table 19 — Ultimate torsion shear stress in lightweight aggregate concrete beams	40
Table 20 — Strength of concrete	43

	Page
Table 22 — Compressive stresses in concrete for serviceability limit states	43
Table 23 — Allowable compressive stresses at transfer	43
Table 24 — Flexural tensile stresses for class 2 members: serviceability limit state: cracking	44
Table 25 — Hypothetical flexural tensile stresses for class 3 members	45
Table 26 — Depth factor for tensile stresses for class 3 members	45
Table 27 — Conditions at the ultimate limit state for rectangular beams with pre-tensioned tendons, or with post-tensioned tendons having effective bond	47
Table 28 — Maximum shear stress	49
Table 29 — Shrinkage of concrete	51
Table 30 — Design bursting tensile forces in end blocks	54
Table 31 — Ultimate longitudinal shear stress, v_1 , and values of k_1 for composite members	63
Table 32 — Flexural tensile stresses in in situ concrete	63
Table 33 — Values of ρ_0 for calculation of shrinkage curvatures	67
Table 34 — Values of K_1 for various bending moment diagrams	68
Table 35 — Modulus of elasticity	69
Table 36 — Minimum cover to ducts perpendicular to plane of curvature	76
Table 37 — Minimum distance between centre lines of ducts in plane of curvature	77
Publications referred to	Inside back cover

Foreword

This Part of BS 5400 has been prepared under the direction of the Civil Engineering and Building Structures Standards Committee. It supersedes BS 5400-4:1984 which is withdrawn.

This edition introduces technical changes but does not constitute a full review or revision of the standard, which will be undertaken in due course. Changes from the 1984 edition are indicated by a sideline in the margin.

BS 5400 is a document combining codes of practice to cover the design and construction of steel, concrete and composite bridges and specifications for loads, materials and workmanship. It comprises the following Parts and Sections:

- *Part 1: General statement;*
- *Part 2: Specification for loads;*
- *Part 3: Code of practice for design of steel bridges;*
- *Part 4: Code of practice for design of concrete bridges;*
- *Part 5: Code of practice for design of composite bridges;*
- *Part 6: Specification for materials and workmanship, steel;*
- *Part 7: Specification for materials and workmanship, concrete, reinforcement and prestressing tendons;*
- *Part 8: Recommendations for materials and workmanship, concrete reinforcement and prestressing tendons;*
- *Part 9: Bridge bearings;*
- *Section 9.1: Code of practice for design of bridge bearings;*
- *Section 9.2: Specification for materials, manufacture and installation of bridge bearings;*
- *Part 10: Code of practice for fatigue.*

A British Standard does not purport to include all the necessary provisions of a contract. Users of British Standards are responsible for their correct application.

Compliance with a British Standard does not of itself confer immunity from legal obligations.

Summary of pages

This document comprises a front cover, an inside front cover, pages i to x, pages 1 to 78, an inside back cover and a back cover.

This standard has been updated (see copyright date) and may have had amendments incorporated. This will be indicated in the amendment table on the inside front cover.

1 Scope

This Part of BS 5400 gives recommendations for the design of concrete bridges. It contains much in common with BS 8110 which deals with the structural use of concrete.

After stating the objectives and requirements of design, particular recommendations are given for reinforced concrete, prestressed concrete and composite concrete construction.

Structural elements included are beams, slabs, columns and walls, bases, tension members and connections between precast concrete members.

NOTE The titles of the publications referred to in this British Standard are listed on the inside back cover.

2 Definitions and symbols

2.1 Definitions

2.1.1

general

for the purposes of this Part of BS 5400 the definitions given in Part 1 apply

all formulae are based on SI units in newtons and millimetres unless otherwise stated

2.1.2

partial load factors

for the sake of clarity the factors that together comprise the partial safety factor for loads are restated as follows

design loads, Q^* , are the loads obtained by multiplying the nominal loads, Q_k , by γ_{fL} , the partial safety factor for loads. γ_{fL} is a function of two individual factors, γ_{f1} and γ_{f2} , which take account of the following:

- γ_{f1} possible unfavourable deviations of the loads from their nominal values;
- γ_{f2} reduced probability that various loadings acting together will all attain their nominal values simultaneously.

the relevant values of the function γ_{fL} ($= \gamma_{f1} \cdot \gamma_{f2}$) are given in Part 2

the design load effects, S^* , should be obtained from the design loads by the relation:

$$S^* = \gamma_{f3} (\text{effects of } Q^*)$$

where

- γ_{f3} is a factor that takes account of inaccurate assessment of the effects of loading, unforeseen stress distribution in the structure and variations in dimensional accuracy achieved in construction.

the values of γ_{f3} are given in clause 4

2.1.3

Materials

2.1.3.1

characteristic strength

unless otherwise stated, that value of the cube strength of concrete, f_{cu} , the yield or proof strength of reinforcement, f_y , or the breaking load of a prestressing tendon, f_{pu} , below which not more than 5 % of all possible test results may be expected to fall

2.1.3.2

characteristic stress

that value of stress at the assumed limit of linearity on the stress-strain curve for the material

2.2 Symbols. The symbols used in this Part of BS 5400 are as follows.

A_c	area of concrete
A_{cf}	area of effective concrete flange
A_{con}	contact area
A_{cor}	area of core of the concrete section
A_e	area of fully anchored reinforcement per unit length crossing the shear plane
A_o	area enclosed by the median wall line
A_{ps}	area of prestressing tendons in the tension zone
A_s	area of tension reinforcement
A'_s	area of compression reinforcement
A'_{s1}	area of compression reinforcement in the more highly compressed face
A_{s2}	area of reinforcement in other face
A_{sa}	area of longitudinal tensile reinforcement
A_{sc}	area of longitudinal reinforcement (for columns)
A_{sL}	cross-sectional area of one bar of longitudinal reinforcement provided for torsion
A_{st}	cross-sectional area of one leg of a closed link
A_{sup}	supporting area
A_{sv}	cross-sectional area of the legs of a link
A_t	area of transverse reinforcement
a	deflection
a'	distance from compression face to point at which the crack width is being calculated
a_b	centre-to-centre distance between bars

a_{cent}	distance of the centroid of the concrete flange from the centroid of the composite section	E_{28}	secant modulus of elasticity of the concrete at the age of 28 days
a_{cr}	distance from the point (crack) considered to the surface of nearest longitudinal bar	e	base of Napierian logarithms
a_e	modular ratio at first introduction of stress	e	eccentricity
a_s	distance of the centroid of the steel from the centroid of the net concrete section	e_x	resultant eccentricity of load at right-angles to plane of wall
a_v	distance between the line of action or point of application of the load and the critical section or supporting member	F_{bst}	tensile bursting force
b	width or breadth of section	F_{bt}	tensile force due to ultimate loads in a bar or group of bars
b_a	average breadth of section excluding the compression flange	F_{h}	maximum horizontal ultimate load
b_c	breadth of compression face	F_v	maximum vertical ultimate load
b_{col}	width of column	f	stress
b_s	width of section containing effective reinforcement for punching shear	f_{bs}	local bond stress
b_t	breadth of section at level of tension reinforcement	f_c	a constant stress in the concrete
b_w	breadth of web or rib of a member	f_{cav}	average compressive stress in the flexural compressive zone
c_{nom}	nominal cover	f_{ci}	concrete strength at (initial) transfer
D_c	density of lightweight aggregate concrete at time of test	f_{cj}	stress in concrete at application of an increment of stress at time j
d	effective depth to tension reinforcement	f_{co}	stress in concrete at the level of the tendon due to initial prestress and dead load
d'	depth of compression reinforcement	f_{cp}	compressive stress at the centroidal axis due to prestress
d_c	depth of concrete in compression	f_{cu}	characteristic concrete cube strength
d_e	effective depth for a solid slab or rectangular beam; otherwise the overall depth of the compression flange	f_{pb}	tensile stress in tendons at (beam) failure
d_o	depth to additional reinforcement to resist horizontal loading	f_{pe}	effective prestress (in tendon)
d_t	effective depth from the extreme compression fibre to either the longitudinal bars around which the stirrups pass or the centroid of the tendons, whichever is the greater	f_{pt}	stress due to prestress
d_2	depth from the surface to the reinforcement in the other face	f_{pu}	characteristic strength of prestressing tendons
E_c	static secant modulus of elasticity of concrete	f_{s2}	stress in reinforcement in other face
E_{cf}	modulus of elasticity of flange concrete	f_t	maximum principal tensile stress
E_{cq}	dynamic tangent modulus of elasticity of concrete	f_y	characteristic strength of reinforcement
E_s	modulus of elasticity of steel	f_{yc}	design strength of longitudinal steel in compression
$(EI)_c$	flexural rigidity of the column cross section	f_{yL}	characteristic strength of longitudinal reinforcement
		f_{yv}	characteristic strength of link reinforcement
		h	overall depth (thickness) of section (in plane of bending)
		h_{agg}	maximum size of aggregate
		h_e	effective thickness
		h_f	thickness of flange

h_{\max}	larger dimension of section	l_0	clear height of column between end restraints
h_{\min}	smaller dimension of section	l_{sb}	length of straight reinforcement beyond the intersection with the link
h_{wo}	wall thickness where the stress is determined	l_t	transmission length
h_x	overall depth of the cross section in the plane of bending M_{iy}	M	bending moment due to ultimate loads
h_y	overall depth of the cross section in the plane of bending M_{ix}	M_a	increased moment in column
I	second moment of area	M_{cr}	cracking moment at the section considered
i	radius of gyration	M_{cs}	hogging restraint moment at an internal support of a continuous composite beam and slab section due to differential shrinkage
j	age at application of increment of stress	M_g	moment due to permanent loads
j_i	age of first loading	M_i	maximum initial moment in a column due to ultimate loads
j_m	number of days during which hardening takes place at $T^\circ\text{C}$	M_{ix}	initial moment about the major axis of a slender column due to ultimate loads
j_∞	age at the end of the life of the structure	M_{iy}	initial moment about the minor axis of a slender column due to ultimate loads
K	a factor depending on the type of duct or sheath used	M_q	moment due to live loads
K_1	depends on the shape of the bending moment diagram	M_{tx}	total moment about the major axis of a slender column due to ultimate loads
k	a constant (with appropriate subscripts)	M_{ty}	total moment about the minor axis of a slender column due to ultimate loads
k_c	depends on the composition of the concrete	M_u	ultimate resistance moment
k_e	depends on the effective thickness of the member	M_{ux}	ultimate moment capacity in a short column assuming ultimate axial load and bending about the major axis only
k_j	covers the development of the deferred deformation with time	M_{uy}	ultimate moment capacity in a short column assuming ultimate axial load and bending about the minor axis only
k_L	depends on environmental conditions	M_x, M_y	moments about the major and minor axes of a short column due to ultimate loads
k_m	depends on the hardening (maturity) of the concrete at the age of loading	M_0	moment necessary to produce zero stress in the concrete at the depth d
k_{mi}	coefficient k_m for age at first loading	M_1	smaller initial end moment due to ultimate loads (assumed negative if the column is bent in double curvature)
k_r	depends on grade of reinforcement	M_2	larger initial end moment due to ultimate loads (assumed positive)
k_t	depends on the type of tendon	N	ultimate axial load at section considered
k_1	depends on the concrete bond across the shear plane	N_u	ultimate resistance axial load
k_2	depends on the geometric ratio of longitudinal reinforcement	N_{uz}	axial loading capacity of a column ignoring all bending
L_s	length of shear plane	n_w	ultimate axial load per unit length of wall
l	distance from face of support at the end of a cantilever, or effective span of a member	P_f	effective prestressing force after all losses
l_e	effective height of a column or wall		
l_{ex}	effective height for bending about the major axis		
l_{ey}	effective height for bending about the minor axis		

P_h	horizontal component of the prestressing force after all losses	v_t	torsional shear stress
P_k	basic load in tendon	v_{tmin}	minimum ultimate torsional shear stress for which reinforcement is required
P_o	prestressing force in the tendon at the jacking end (or at tangent point near jacking end)	v_{tu}	ultimate torsional shear stress
P_x	prestressing force at distance x from jack	x	neutral axis depth
Q^*	design load	x_1	smaller centre line dimension of a link
Q_k	nominal load	y	distance of the fibre considered in the plane of bending from the centroid of the concrete section
r	internal radius of bend	y_o	half the side of end block
r_{ps}	radius of curvature of a tendon	y_{po}	half the side of loaded area
r_b	radius of curvature of a beam at mid span or, for cantilevers, at the support section	y_1	larger centre line dimension of a link
r_{cs}	shrinkage radius of curvature	z	lever arm
r_x	radius of curvature of a member at point x	α	orientation of the reinforcement in the transverse direction
S^*	design load effects	α_e	modular ratio
s_L	spacing of longitudinal reinforcement	α_n	coefficient as a function of column axial load
s_v	spacing of links along the member	α_1	angle between the axis of the design moment and the direction of the tensile reinforcement
T	torsional moment due to ultimate loads	α_2	angle of friction at the joint
T	temperature (in degrees Celsius)	β_{cc}	ratio of total creep to elastic deformation
t	time	$\gamma_{f1}, \gamma_{f2}, \gamma_{f3}$	partial load factors
u	perimeter	γ_{fL}	product of γ_{f1}, γ_{f2}
u_s	effective perimeter of tension reinforcement	γ_m	partial safety factor for strength
V	shear force due to ultimate loads	Δ_{cc}	concrete creep deformation
V_c	ultimate shear resistance of concrete	Δ_{cct}	creep strain
V_{co}	ultimate shear resistance of a section uncracked in flexure	Δ_{cs}	concrete shrinkage deformation
V_{cr}	ultimate shear resistance of a section cracked in flexure	Δ_{cst}	shrinkage at time t
V_l	longitudinal shear force due to ultimate load	$\Delta_{f\infty}$	change in stress in concrete due to creep at time t_∞
V_{ux}	ultimate shear capacity of a section for the x-x axis	Δ_p	loss of prestress due to shrinkage and creep
V_{uy}	ultimate shear capacity of a section for the y-y axis	δ_m	degree of hardening at moment of loading
V_x	applied shear due to ultimate loads for the x-x axis	ϵ	strain
V_y	applied shear due to ultimate loads for the y-y axis	ϵ_{c1}	creep strain in concrete at the level of the tendon at time of loading
v	shear stress	ϵ_{c2}	creep strain in concrete at the centroid of the section at time of loading
v_c	ultimate shear stress in concrete	ϵ_{cs}	free shrinkage strain
v_l	ultimate longitudinal shear stress per unit area of contact surface	ϵ_{diff}	differential shrinkage strain
		ϵ_m	average strain

ϵ_s	strain in tension reinforcement
ϵ_1	strain at level considered
η	relaxation coefficient
θ_s	angle between the compression face and the tension reinforcement
λ_w	coefficient for walls dependent upon concrete used
μ	coefficient of friction
ξ	depth factor
ρ	geometrical ratio of reinforcement, is equal to A_s/bd
ρ_o	coefficient which depends upon the percentage of tension and compression steel in the section
ΣA_{sv}	area of shear reinforcement
Σbd	area of the critical section
Σu_s	sum of the effective perimeters of the tension reinforcement
Φ	size (nominal diameter) of bar or tendon
ϕ	creep coefficient
ϕ_{ti}	creep coefficient at time t for load applied at time i
ϕ_1	creep coefficient for prestressed construction
ϕ_2	creep reduction coefficient for axially loaded symmetrically reinforced concrete members
ϕ_3	creep reduction coefficient for axially loaded singly reinforced concrete members
ϕ_4	creep reduction coefficient for symmetrically reinforced concrete members subjected to bending moment
ϕ_5	creep reduction coefficient for singly reinforced concrete members subjected to bending moment

3 Limit state philosophy

3.1 General. The limit states of 4.1.1 and 4.1.2 should be considered in the design so as to ensure an adequate degree of safety and serviceability. The usual approach will be to design on the basis of the limit state expected to be most critical and then to check that the remaining limit states will not be reached and that all other requirements will be met.

Consideration of other factors, such as deflection, fatigue and durability, might need to be made as referred to in 4.1.3.

3.2 Serviceability limit state. The design should be such that the structure will not suffer local damage which would shorten its intended life or incur excessive maintenance costs. In particular, calculated crack widths should not exceed those permitted in 4.1.1.1.

3.3 Ultimate limit state. The strength of the structure should be sufficient to withstand the design loads, taking due account of the possibility of overturning or buckling. The assessment should ensure that collapse will not occur as a result of rupture of one or more critical sections, by overturning or by buckling caused by elastic or plastic instability, having due regard to the effects of sway when appropriate.

4 Design: general

4.1 Limit state requirements

4.1.1 Serviceability limit states

4.1.1.1 Cracking. Cracking of concrete should not adversely affect the appearance or durability of the structure. The Engineer should satisfy himself that any cracking will not be excessive, having regard to the requirements of the particular structure and the conditions of exposure. In the absence of special investigations, the following limits should be adopted.

a) *Reinforced concrete.* Design crack widths, as calculated in accordance with 5.8.8.2, should not exceed the values given in Table 1 under the loading given in 4.2.2.

b) *Prestressed concrete structures or elements.* These are classified by reference to flexural tensile limitations. The categories are as follows:

class 1: no tensile stress permitted;

class 2: tensile stresses permitted, in accordance with Table 24, but no visible cracking;

class 3: tensile stress permitted, in accordance with Table 25, but with design crack widths limited to the values of Table 1.

A structure may not have a unique classification and reference should be made to the appropriate bridge authority for its requirements.

Recommendations for load combinations appropriate to particular categories are given in 4.2.2.

4.1.1.2 Vibration. The dynamic effects of standard highway or railway loading on commonly occurring types of bridges are deemed to be covered in the allowance for impact which is included in the nominal live load; the requirements of Part 2 need only be applied to foot-bridges or to the structural components of bridges whose prime function is to carry footway loading.

4.1.1.3 Stress limitations. To prevent unacceptable deformations occurring, compressive stresses in concrete and stresses in steel should be calculated by linear elastic analysis for load combinations 1 to 5 in any of the following applications:

- a) for all prestressed concrete construction;
- b) for all composite concrete construction (see 7.4);
- c) where the effects of differential settlement, temperature difference, and creep and shrinkage of concrete are not considered at the ultimate limit state;
- d) where a plastic method (see 4.4.3.1) or redistribution of moments (see 5.2.2) are used for the analysis of the structure at the ultimate limit state;
- e) under global and local direct and bending effects where these are considered separately at the ultimate limit state.

For reinforced and prestressed concrete, the compressive and tensile stress limitations are summarized in Table 2.

4.1.2 Ultimate limit states

4.1.2.1 Rupture or instability. The assessment of the structure under the design loads appropriate to this limit state should ensure that prior collapse does not occur as a result of rupture of one or more critical sections, buckling caused by elastic or plastic instability, or overturning.

The effects of creep and shrinkage of concrete, temperature difference and differential settlement need not be considered at the ultimate limit state provided that these effects have been included in the appropriate load combinations to check the stress limitations given in 4.1.1.3 for the serviceability limit state.

4.1.2.2 Vibration. The criterion for vibration at the serviceability limit state is deemed to satisfy this clause.

Table 1 — Design crack widths

Environment	Examples	Design crack width
<p><i>Extreme</i></p> <p>Concrete surfaces exposed to: abrasive action by sea water or water with a pH \leq 4.5</p>	<p>Marine structures</p> <p>Parts of structure in contact with moorland water</p>	<p>mm</p> <p>0.10</p>
<p><i>Very severe</i></p> <p>Concrete surfaces directly affected by: de-icing salts or sea water spray</p>	<p>Walls and structure supports adjacent to the carriageway</p> <p>Parapet edge beams</p> <p>Concrete adjacent to the sea</p>	0.15
<p><i>Severe</i></p> <p>Concrete surfaces exposed to: driving rain or alternate wetting and drying</p>	<p>Wall and structure supports remote from the carriageway</p> <p>Bridge deck soffits</p> <p>Buried parts of structures</p>	0.25
<p><i>Moderate</i></p> <p>Concrete surfaces above ground level <i>and</i> fully sheltered against all of the following: rain, de-icing salts, sea water spray</p> <p>Concrete surfaces permanently saturated by water with a pH $>$ 4.5</p>	<p>Surface protected by bridge deck water-proofing or by permanent formwork</p> <p>Interior surface of pedestrian subways, voided superstructures or cellular abutments</p> <p>Concrete permanently under water</p>	0.25

Table 2 — Stress limitations for the serviceability limit state

Material	Type of stress under design loading	Type of construction	
		Reinforced concrete	Prestressed concrete
Concrete	Triangular or near triangular compressive stress distribution (e.g. due to bending)	$0.50f_{cu}$	$0.40f_{cu}$
	Uniform or near uniform compressive stress distribution (e.g. due to axial loading)	$0.38f_{cu}$	$0.30f_{cu}$
Reinforcement	Compression } Tension }	$0.75f_y$	Not applicable
Prestressing tendons	Tension	Not applicable	Deemed to be satisfied by 6.7.1

NOTE See 7.3.3 for limiting flexural stresses in joints for post-tensioned segmental construction.

4.1.3 Other considerations

4.1.3.1 Deflections. The deflection of the structure, or any part of it, should not be such as to affect adversely the appearance or efficiency of the structure.

The appearance and function of concrete superstructures are normally unaffected although calculations may be required in the following circumstances:

- where minimum specified clearances may be violated;
- where drainage difficulties might ensue;
- where the method of construction may require careful control of profile, e.g. at discontinuities in serial construction, and where decks comprise abutting prestressed concrete beams.

4.1.3.2 Fatigue. The fatigue life of all bridges should comply with the recommendations of Part 10 (but see also 4.7).

4.1.3.3 Durability. The recommendations in this code regarding concrete cover to the reinforcement and acceptable crack widths (see 4.1.1.1) in association with the cement contents given in Part 8 are intended to meet the durability requirements of almost all structures. Where more severe environments are encountered, however, additional precautions may be necessary, and specialist literature should be consulted.

4.2 Loads, load combinations and partial factors γ_{fL} and γ_{f3}

4.2.1 Loads. The nominal values of loads (and imposed deformations) are given in Part 2.

Creep and shrinkage of concrete and prestress (including secondary effects in statically indeterminate structures) are load effects associated with the nature of the structural material being used; where they occur, they should be regarded as permanent loads.

4.2.2 Serviceability limit state. For the limitations given in 4.1.1.1 a) for reinforced concrete, load combination 1 only should be considered. Where type HB loading is to be taken into account, only 25 units should be considered. The type HA wheel load need not be considered except for cantilever slabs and the top flanges in beam-and-slab, voided slab and box-beam construction.

For the limitations given in 4.1.1.1 b) for prestressed concrete, the load combinations considered for the appropriate category should be as follows:

- class 1 under load combination 1 (as modified in the preceding paragraph), except that live loading may be ignored for lightly trafficked highway bridges and railway bridges where the live loading is controlled; and
- class 2 or class 3 for load combinations 2 to 5.

For the stress limitations given in 4.1.1.3, load combinations 1 to 5 should be considered.

The values of the partial safety factor, γ_{fL} , for the individual loading comprising combinations 1 to 5 are given in Part 2. The value of γ_{fL} for creep and shrinkage of concrete and for prestress (including secondary effects in statically indeterminate structures) should be taken as 1.0.

The value of γ_{f3} should be taken as 1.0.

4.2.3 Ultimate limit state. To check the recommendations of 4.1.2, load combinations 1 to 5 should be considered.

The values of the partial safety factor, γ_{FL} , for the individual loadings comprising combinations 1 to 5 are given in Part 2. The values of γ_{FL} for the effects of shrinkage and, where relevant, of creep should be taken as 1.2. In calculating the resistance of members to vertical shear and torsion, γ_{FL} for the prestressing force should be taken as 1.15 where it adversely affects the resistance and 0.87 in other cases. In calculating secondary effects in statically indeterminate structures, γ_{FL} for the prestressing force may be taken as 1.0.

The value of γ_{f3} should be taken as 1.10, except that where plastic methods (see 4.4.3.1) are used for the analysis of the structure, γ_{f3} should be taken as 1.15.

4.2.4 Deflection. Minimum specified clearances should be maintained under the action of load combination 1.

The appearance and drainage characteristics of the structure should be considered under the action of permanent loads only.

The values of γ_{FL} for the individual loads and the value of γ_{f3} should be those appropriate to the serviceability limit state.

4.3 Properties of materials

4.3.1 General. The characteristic strengths of materials are given in 5.1.4 and 6.1.4. In general, in analysing a structure to determine load effects, the material properties appropriate to the characteristic strength should be used, irrespective of the limit state being considered.

For the analysis of sections, the material properties to be used for the individual limit states are as follows.

- a) Serviceability limit state. The characteristic stresses, which should be taken as $0.75f_y$ for reinforcement, $0.5f_{cu}$ for concrete in compression and $0.56\sqrt{f_{cu}}$ for tension in concrete for prestressed concrete.
- b) Ultimate limit state. The characteristic strengths given in 4.3.2.

The appropriate γ_m values are given in 4.3.3.

4.3.2 Material properties

4.3.2.1 Concrete. In assessing the strength of sections at the ultimate limit state, the design stress-strain curve for normal weight concrete may be taken from Figure 1, using the value of γ_m for concrete given in 4.3.3.3.

The modulus of elasticity to be used for elastic analysis should be appropriate to the cube strength of the concrete at the age considered and in the absence of special investigations should be obtained as follows.

- a) *Analysis of structure.* To determine the effects of permanent and short term loading: the appropriate value given in Table 3.

To determine the effects of imposed deformations and for the calculation of deflections: an appropriate intermediate value between that given in Table 3 and half that value.

- b) *Analysis of section.* To determine crack widths and stresses due to the effects of permanent and short term loading and imposed deformations: an appropriate intermediate value between that given in Table 3 and half that value.

The appropriate intermediate value of the modulus of elasticity mentioned in a) and b) should reflect the proportion of permanent and short term effects in the combination.

Where a more precise elastic analysis for permanent loads is appropriate, the effects of creep and shrinkage should be assessed more accurately. Information on creep and shrinkage, based on CEB/FIP International Recommendations, is given in Appendix C.

Further information on the elastic deformation of concrete is given in Appendix B.

Table 3 — Modulus of elasticity of concrete under short term loading

Characteristic strength (or cube strength of concrete at the age considered)	Modulus of elasticity of concrete, E_c
N/mm ²	kN/mm ²
20	25
25	26
30	28
40	31
50	34
60	36

The effect of creep under long term loading is normally allowed for by using half the values in Table 3 for the modulus of elasticity.

For lightweight concrete having an air dry density between 1 400 kg/m³ and 2 300 kg/m³, the values given in Table 3 should be multiplied by $(D_c/2\ 300)^2$ where D_c is the density of the lightweight aggregate concrete in kg/m³. Alternatively, the value of the elastic modulus for a specific strength may be obtained from tests.

For elastic analysis, Poisson's ratio may be taken as 0.2. The coefficient of thermal expansion may be taken as $12 \times 10^{-6}/^{\circ}\text{C}$ for normal weight concrete. For lightweight concrete and limestone aggregate concrete, the values can be as low as $7 \times 10^{-6}/^{\circ}\text{C}$ and $9 \times 10^{-6}/^{\circ}\text{C}$ respectively.

4.3.2.2 Reinforcement and prestressing steel. The design stress-strain curves may be taken as follows:

- for reinforcement, from Figure 2, using the value of γ_m given in 4.3.3;
- for prestressing steel, from Figure 2, using the value of γ_m given in 4.3.3.

For reinforcement, the modulus of elasticity may be taken as 200 kN/mm^2 for both short and long term loading. For prestressing steel, the short and long term modulus may be taken from Figure 3 or Figure 4 as the appropriate tangent modulus at zero load.

4.3.3 Values of γ_m

4.3.3.1 General. For the analysis of sections, the values of γ_m are summarized in 4.3.3.2 to 4.3.3.4.

4.3.3.2 Serviceability limit state. The values of γ_m applied to the characteristic stresses defined in 4.3.1 are given in Table 4 and have been allowed for in deriving the compressive and tensile stresses given in Table 2 and Table 24.

The higher values for prestressed concrete arise because the whole concrete cross section is normally in compression and therefore creep will be greater than in reinforced concrete. Similarly in reinforced concrete creep will be greater where the compressive stress distribution is uniform over the whole cross section.

4.3.3.3 Ultimate limit state. For both reinforced concrete and prestressed concrete, the values of γ_m applied to the characteristic strengths (see 4.3.1) are 1.50 for concrete and 1.15 for reinforcement and prestressing tendons.

4.3.3.4 Fatigue. For reinforced concrete, the value of γ_m applied to the stress range limitations given in 4.7 for reinforcement is 1.00.

4.4 Analysis of structure

4.4.1 General. The requirements of methods of analysis appropriate to the determination of the distribution of forces and deformations which are to be used in ascertaining that the limit state criteria are satisfied are described in Part 1. The effects of shear lag on the analysis of the structure may be neglected, except for cable-stayed superstructures.

4.4.2 Analysis for serviceability limit state

4.4.2.1 General. Elastic methods of analysis should be used to determine internal forces and deformations. The flexural stiffness constants (second moment of area) for sections of discrete members or unit widths of slab elements may be based on any of the following.

- Concrete section.** The entire member cross section, ignoring the presence of reinforcement.
- Gross transformed section.** The entire member cross section including the reinforcement, transformed on the basis of modular ratio.
- Net transformed section.** The area of the cross section which is in compression together with the tensile reinforcement, transformed on the basis of modular ratio.

Table 4 — Values of γ_m for the serviceability stress limitations

Material	Type of stress	Type of construction	
		Reinforced concrete	Prestressed concrete
Concrete	Triangular or near-triangular compressive stress distribution (e.g. due to bending)	1.00	1.25
	Uniform or near-uniform compressive stress distribution (e.g. due to axial loading)	1.33	1.67
	Tension	Not applicable	1.25 pre-tensioned 1.55 post-tensioned
Reinforcement	Compression } Tension }	1.00	Not applicable
Prestressing tendons	Tension	Not applicable	Not required

A consistent approach should be used which reflects the different behaviour of various parts of the structure.

Axial, torsional and shearing stiffness constants, when required by the method of analysis, should be based on the concrete section and used with a) or b). Moduli of elasticity and shear moduli values should be appropriate to the characteristic strength of the concrete.

4.4.2.2 Methods of analysis and their requirements. The method of analysis should ideally take account of all the significant aspects of behaviour of a structure governing its response to loads and imposed deformations.

4.4.3 Analysis for ultimate limit state

4.4.3.1 General. Elastic methods may be used to determine the distribution of forces and deformations throughout the structure. Stiffness constants should be based on the section properties as used for the analysis of the structure at the serviceability limit state (see 4.4.2.1). However, plastic methods of analysis (e.g. plastic hinge methods for beams, or yield line methods for slabs) may be used where such methods can be shown adequately to model the combined local and global effects of all loads due to combinations 1 to 5 as given in Part 2. The use of such methods should be agreed with the relevant bridge authority.

4.4.3.2 Methods of analysis and their requirements. The application of elastic methods of analysis in association with the design loads for the ultimate limit state in general leads to safe lower bound solutions; these may be refined, and made less conservative, by reference to test results or specialist literature. For longitudinal members load effects due to restraint of torsional and distortional warping may be neglected.

When treating local effects, elastic methods may be applied to derive the in-plane forces and moments due to out-of-plane loading; alternatively, yield line methods may be used for the local wheel loads. The section should then be detailed according to clauses 5, 6 and 7, as appropriate.

4.5 Analysis of section

4.5.1 Serviceability limit state. At any section, an elastic analysis should be carried out to satisfy recommendations of 4.1.1. In-plane shear flexibility in concrete flanges (shear lag effects) should be allowed for. This may be done by taking an effective width of flange (see 5.3.1.2).

4.5.2 Ultimate limit state. The strength of critical sections should be assessed in accordance with clause 5, 6 or 7 to satisfy the recommendations of 4.1.2. In-plane shear flexibility in concrete flanges (shear lag effects) may be ignored.

4.6 Deflection. Deflection should be calculated for the most unfavourable distributions of loading for the member (or strip of slab) and may be derived from an elastic analysis of the structure. The material properties, stiffness constants and calculation of deflections may be based on the information given in 4.3.2.1 or in Appendix A.

4.7 Fatigue. The effect of repeated live loading on the fatigue strength of a bridge should be considered in respect of reinforcing bars that have been subjected to welding; details of compliance criteria are given in Part 10.

Welding may be used to connect bars subjected to fatigue loading provided that:

- a) the connection is made to standard workmanship levels as given in Part 7;
- b) the welded bar is not part of a deck slab spanning between longitudinal and/or transverse members and subjected to the effect of concentrated wheel loads in a traffic lane;
- c) the detail has an acceptable fatigue life determined in accordance with Part 10;
- d) lap welding is not used.

For unwelded reinforcing bars, the stress range under load combinations 1 to 5 for the serviceability limit state should be limited to 325 N/mm² for grade 460 bars and to 265 N/mm² for grade 250 bars.

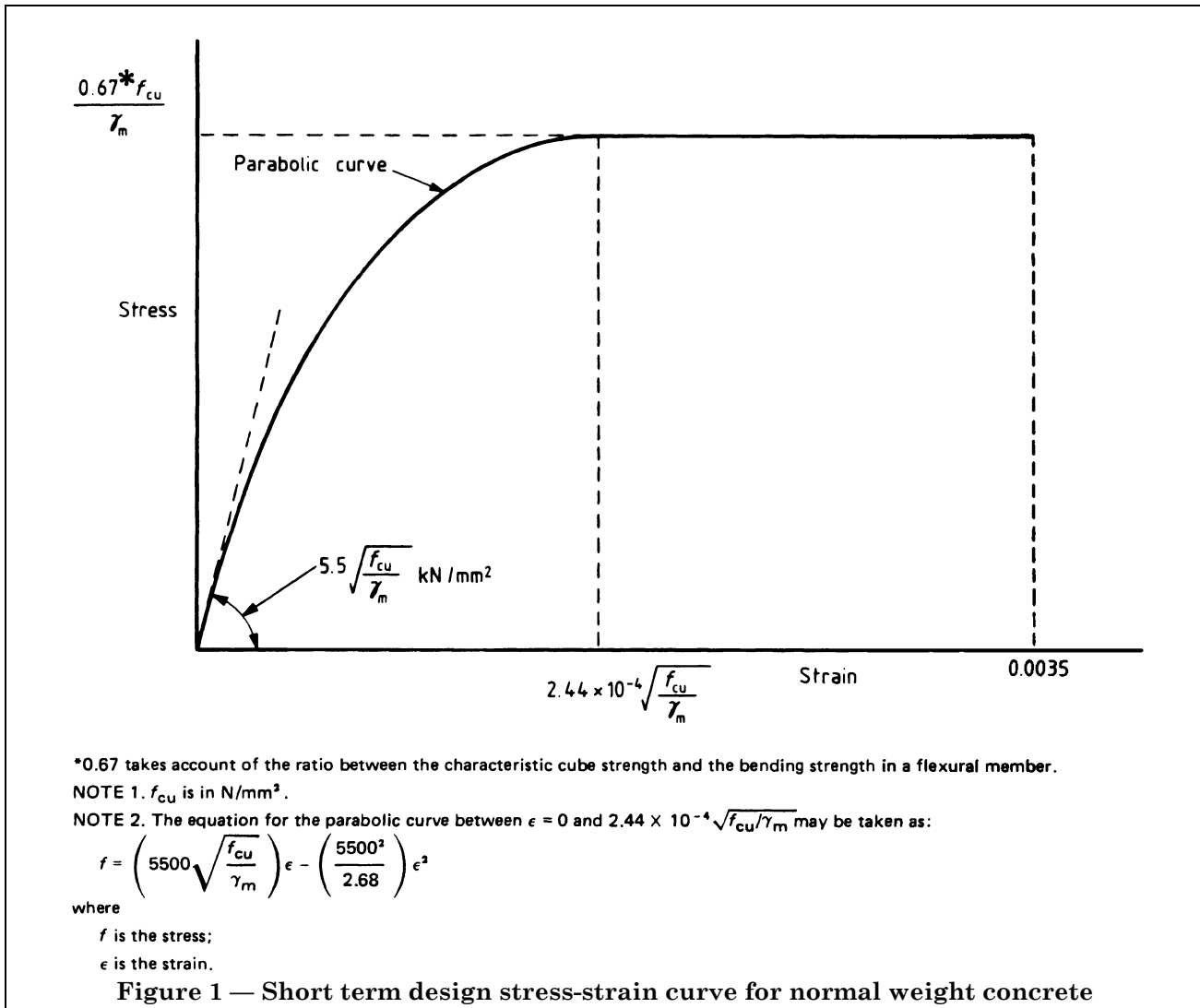

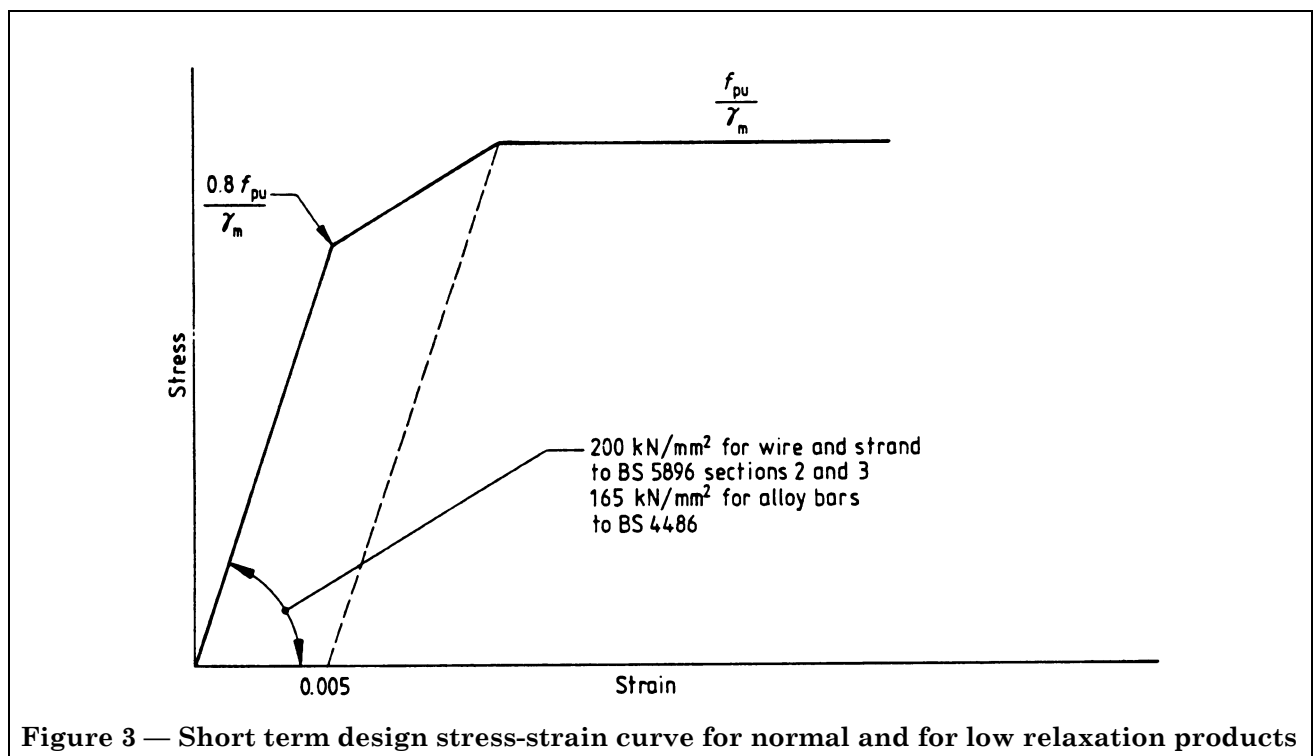
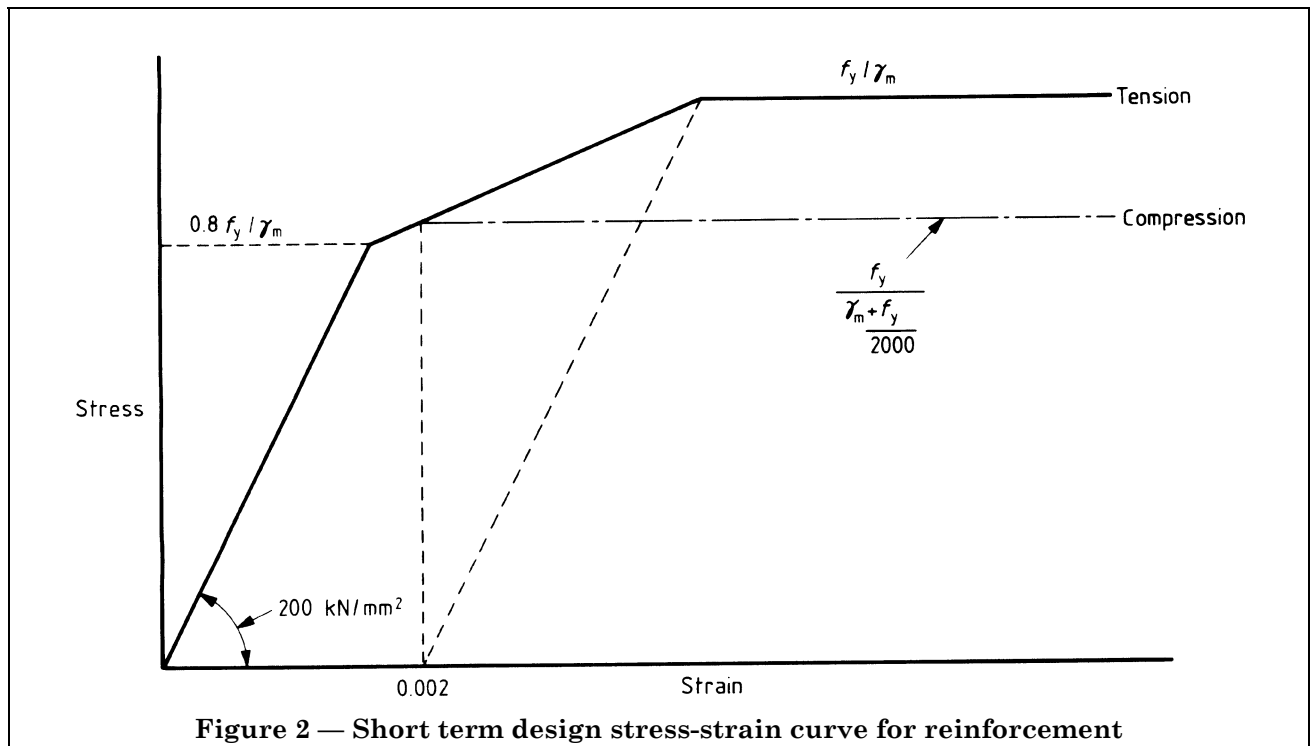
Figure 4 — *Figure deleted*

4.8 Combined global and local effects

4.8.1 General. In addition to the design of individual primary and secondary elements to resist loading applied directly to them, it is also necessary to consider the loading combination that produces the most adverse effects due to global and local loading where these coexist in an element.

4.8.2 Analysis of structure. Analysis of the structure may be accomplished either by one overall analysis (e.g. using finite elements) or by separate analyses for global and local effects. In the latter case the forces and moments acting on the element from global and local effects should be combined as appropriate.

4.8.3 Analysis of section. Section analysis for the combined global and local effects should be carried out in accordance with 4.5 to satisfy the recommendations of 4.1.

a) Serviceability limit state

1) For reinforced concrete elements, the total crack width due to combined global and local effects should be determined in accordance with 5.8.8.2.

2) For prestressed concrete elements, coexistent stresses, acting in the direction of prestress, may be added algebraically in checking the stress limitations.

b) *Ultimate limit state.* The resistance of the section to direct and flexural effects should be derived from the direct strain due to global effects combined with the flexural strain due to local effects. However, in the case of a deck slab the resistance to combined global and local effects is deemed to be satisfactory if each of these effects is considered separately.

5 Design and detailing: reinforced concrete

5.1 General

5.1.1 Introduction. This clause gives methods of analysis and design which will in general ensure that, for reinforced concrete structures, the recommendations set out in 4.1.1 and 4.1.2 are met. Other methods may be used provided they can be shown to be satisfactory for the type of structure or member considered. In certain cases the assumptions made in this clause may be inappropriate and the Engineer should adopt a more suitable method having regard to the nature of the structure in question.

5.1.2 Limit state design of reinforced concrete

5.1.2.1 Basis of design. Clause 5 follows the limit state philosophy set out in clauses 3 and 4 but, as it is not possible to assume that a particular limit will always be the critical one, design methods are given for both the ultimate and the serviceability limit states.

In general, the design of reinforced concrete members is controlled by the ultimate limit state, but the limitations on crack width and, where applicable, stresses at the serviceability limit state given in 4.1.1.3 should also be met.

Where a plastic method or redistribution of moments is used for the analysis of the structure at the ultimate limit state, or where critical parts of the structure are subjected to the “extreme” or “very severe” category of exposure, the design is likely to be controlled by the serviceability limit state of cracking.

5.1.2.2 Durability. In 5.8.2 guidance is given on the nominal cover to reinforcement that should be provided to ensure durability.

5.1.2.3 Other limit states and considerations. Clause 5 does not make recommendations concerning “vibration” or “other limit states” and, for these and other considerations, reference should be made to 4.1.1.2 and 4.1.3.

5.1.3 Loads. In clause 5 the design load effects (see 2.1) for the ultimate and serviceability limit states are referred to as “ultimate loads” and “service loads” respectively.

The values of the “ultimate loads” and “service loads” to be used in design are derived from Part 2 and 4.2.

In clause 5, when analysing sections, the terms “strength”, “resistance” and “capacity” are used to describe the design strength of the section.

5.1.4 Strength of materials

5.1.4.1 Definition of strengths. In clause 5 the design strengths of materials for the ultimate limit state are expressed in all the tables and equations in terms of the “characteristic strength” of the material. Unless specifically stated otherwise, all equations, figures and tables include allowances for γ_m , the partial safety factor for material strength.

5.1.4.2 Characteristic strength of concrete. The characteristic cube strengths of concrete are given in Part 7, and those which may be specified for reinforced concrete are quoted in Table 5, together with their related cube strengths at other ages. The values given in Table 5 do not include any allowance for γ_m .

Design should be based on the characteristic strength.

5.1.4.3 Characteristic strength of reinforcement. The characteristic strengths of reinforcement are given in the appropriate British Standards and are quoted in Table 6.

The values given in Table 6 do not include any allowance for γ_m .

5.2 Structures and structural frames

5.2.1 Analysis of structures. Structures should be analysed in accordance with the recommendations of 4.4.

5.2.2 Redistribution of moments. Redistribution of moments obtained by rigorous elastic analysis under the ultimate limit state may be carried out provided the following conditions are met.

- a) Checks are made to ensure that adequate rotation capacity exists at sections where moments are reduced, making reference to appropriate test data.

In the absence of a special investigation, the plastic rotation capacity may be taken as the lesser of:

$$1) 0.008 + 0.035 \left(0.5 - \frac{d_c}{d_e} \right)$$

or

$$2) \frac{0.6\Phi}{d - d_c}$$

but not less than 0 or more than 0.015

where

d_c is the calculated depth of concrete in compression at the ultimate limit state;

d_c is the effective depth for a solid slab or rectangular beam, otherwise the overall depth of the compression flange;

ϕ is the diameter of the smallest tensile reinforcing bar;

d is the effective depth to tension reinforcement.

Table 5 — Strength of concrete

Grade	Characteristic strength, f_{cu} N/mm ²	Cube strength at an age of				
		7 days N/mm ²	2 months ^a N/mm ²	3 months ^a N/mm ²	6 months ^a N/mm ²	1 Year ^a N/mm ²
25	25.0	16.5	27.5	29	30	31
30	30.0	20	33	35	36	37
40	40.0	28	44	45.5	47.5	50
50	50.0	36	54	55.5	57.5	60

^a Increased strengths at these ages should be used only if the Engineer is satisfied that the materials used are capable of producing these higher strengths.

Table 6 — Strength of reinforcement

Designation	Nominal sizes mm	Characteristic strength, f_y N/mm ²
Grade 250 (BS 4449)	8, 10, 12, and 16	250
Grade 460 (BS 4449)	All sizes	460
Cold reduced steel wire (BS 4482)	Up to and including 12	485

- b) Proper account is taken of changes in transverse moments, transverse deflections and transverse shears consequent on redistribution of longitudinal moments by means of a special investigation based on a non-linear analysis.
- c) Shears and reactions used in design are taken as those calculated either prior to redistribution or after redistribution, whichever is greater.
- d) The depth of the members of elements considered is less than 1 200 mm.

5.3 Beams

5.3.1 General

5.3.1.1 Effective span. The effective span of a simply supported member should be taken as the smaller of:

- a) the distance between the centres of bearings or other supports; or
- b) the clear distance between supports plus the effective depth.

The effective span of a member framing into supporting members should be taken as the distance between the shear centres of the supporting member.

The effective span of a continuous member should be taken as the distance between centres of supports except where, in the case of beams on wide columns, the effect of column width is included in the analysis.

The effective length of a cantilever should be taken as its length from the face of the support plus half its effective depth except where it is an extension of a continuous beam when the length to the centre of the support should be used.

5.3.1.2 Effective width of flanged beams. In analysing structures, the full width of flanges may be taken as effective.

In analysing sections at the serviceability limit state, and in the absence of any more accurate determination (such as that given in Part 3), the effective flange width should be taken as the width of the web plus one-tenth of the distance between the points of zero moment (or the actual width of the outstand if this is less) on each side of the web. For a continuous beam the points of zero moment may be taken to be at a distance of 0.15 times the effective span from the support.

In analysing sections at the ultimate limit state the full width of the flanges may be taken as effective.

5.3.1.3 Slenderness limits for beams. To ensure lateral stability, a simply supported or continuous beam should be so proportioned that the clear distance between lateral restraints does not exceed $60b_c$ or $250b_c^2/d$, whichever is the lesser,

where

- d is the effective depth to tension reinforcement;
- b_c is the breadth of the compression face of the beam midway between restraints.

For cantilevers with lateral restraint provided only at the support, the clear distance from the end of the cantilever to the face of the support should not exceed $25b_c$ or $100b_c^2/d$, whichever is the lesser.

5.3.2 Resistance moment of beams

5.3.2.1 Analysis of sections. When analysing a cross section to determine its ultimate moment of resistance the following assumptions should be made.

- a) The strain distribution in the concrete in compression and the strains in the reinforcement, whether in tension or compression, are derived from the assumption that plane sections remain plane.
- b) The stresses in the concrete in compression are either derived from the stress-strain curve in Figure 1 with $\gamma_m = 1.5$ or, in the case of rectangular sections and in flanged, ribbed and voided sections where the neutral axis lies within the flange, the compressive stress may be taken as equal to $0.4f_{cu}$ over the whole compression zone. In both cases the strain at the outermost compression fibre at failure is taken as 0.0035.
- c) The tensile strength of the concrete is ignored.
- d) The stresses in the reinforcement are derived from the stress-strain curves in Figure 2 with $\gamma_m = 1.15$.

In addition, if the ultimate moment of resistance, calculated in accordance with this clause, is less than 1.15 times the required value, the section should be proportioned such that the strain at the centroid of the tensile reinforcement is not less than:

$$0.002 + \frac{f_y}{E_s \gamma_m}$$

where E_s is the modulus of elasticity of the steel.

As an alternative, the strains in the concrete and the reinforcement, due to the application of ultimate loads, may be calculated using the following assumptions.

- e) The strain distribution in the concrete in compression and the strains in the reinforcement, whether in tension or compression, are derived from the assumption that plane sections remain plane.

f) The stresses in the concrete in compression are derived from the stress-strain curve given in Figure 1, with $\gamma_m = 1.5$.

g) The tensile strength of the concrete is ignored.

h) The stresses in the reinforcement are derived from the stress-strain curves in Figure 2 with $\gamma_m = 1.15$.

In using the alternative method of analysis, the calculated strain due to the application of ultimate loads at the outermost compression fibre of the concrete should not exceed 0.0035 and the strain at the centroid of the tensile reinforcement should be not less than $0.002 + f_y/(\gamma_m)$ except where the requirement for the calculated strain in the concrete, due to the application of 1.15 times the ultimate loads, can be satisfied.

In the analysis of a cross section of a beam that has to resist a small axial thrust, the effect of the ultimate axial force may be ignored if it does not exceed $0.1f_{cu}$ times the cross-sectional area.

5.3.2.2 Design charts. The design charts that form Part 3 of BS 8110 include charts, based on Figure 1, Figure 2 and the assumptions in 5.3.2.1, which may be used for the design of beams reinforced in tension only or in tension and compression.

5.3.2.3 Design formulae. Provided that the amount of redistribution of the elastic ultimate moments has been less than 10 %, the following formulae may be used to calculate the ultimate moment of resistance of a solid slab or rectangular beam, or of a flanged beam, ribbed slab or voided slab when the neutral axis lies within the flange.

For sections without compression reinforcement the ultimate moment of resistance may be taken as the lesser of the values obtained from equations 1 and 2. Equations 3 and 4 may be used for sections with compression reinforcement.

A rectangular stress block of maximum depth $0.5d$ and a uniform compression stress of $0.4f_{cu}$ has been assumed.

$$M_u = (0.87f_y) A_s z \quad \text{equation 1}$$

$$M_u = 0.15f_{cu} b d^2 \quad \text{equation 2}$$

$$M_u = 0.15f_{cu} b d^2 + 0.72f_y A'_s (d - d') \quad \text{equation 3}$$

$$(0.87 f_y) A_s = 0.2f_{cu} b d + 0.72f_y A'_s \quad \text{equation 4}$$

where

M_u is the ultimate resistance moment;

A_s is the area of tension reinforcement;

A'_s is the area of compression reinforcement;

b is the width of the section;

d is the effective depth to the tension reinforcement;

d' is the depth to the compression reinforcement;

f_y is the characteristic strength of the reinforcement;

z is the lever arm;

f_{cu} is the characteristic strength of the concrete.

When d'/d is greater than 0.2, equation 3 should not be used and the resistance moment should be calculated with the aid of 5.3.2.1.

The term $0.72f_y$ in equations 3 and 4 is a simplification of the equation:

$$\frac{f_y}{\gamma_m + f_y/2000} \text{ shown on Figure 2.}$$

The lever arm, z , in equation 1 may be calculated from the equation:

$$z = \left(1 - \frac{1.1f_y A_s}{f_{cu} b d}\right) d \quad \text{equation 5}$$

The value z should not be taken as greater than $0.95d$.

The ultimate resistance moment of a flanged beam may be taken as the lesser of the values given by equations 6 and 7, where h_f is the thickness of the flange.

$$M_u = (0.87f_y) A_s \left(d - \frac{h_f}{2}\right) \quad \text{equation 6}$$

$$M_u = 0.4f_{cu} b h_f \left(d - \frac{h_f}{2}\right) \quad \text{equation 7}$$

Where it is necessary for the resistance moment to exceed the value given by equation 7, the section should be analysed in accordance with 5.3.2.1.

5.3.3 Shear resistance of beams

5.3.3.1 Shear stress. The shear stress, v , at any cross section should be calculated from:

$$v = \frac{V}{bd} \quad \text{equation 8}$$

where

- V is the shear force due to ultimate loads;
- b is the breadth of the section which, for a flanged beam, should be taken as the rib width;
- d is the effective depth to tension reinforcement.

In no case should v exceed $0.75\sqrt{f_{cu}}$ or 4.75 N/mm^2 , whichever is the lesser, whatever shear reinforcement is provided.

5.3.3.2 Shear reinforcement. Shear reinforcement should be provided as given in Table 7.

Table 7 — Form and area of shear reinforcement in beams

Value of v (N/mm^2)	Area of vertical shear reinforcement to be provided (mm^2)
$v \leq \xi_s v_c$	$A_{sv} \geq 0.4 b s_v / 0.87 f_{yv}$
$v > \xi_s v_c$	$A_{sv} \geq b s_v (v + 0.4 - \xi_s v_c) / 0.87 f_{yv}$

In Table 7:

- v is the shear stress;
- ξ_s is the depth factor (see Table 9);
- v_c is the ultimate shear stress in concrete (see Table 8);
- A_{sv} is the cross-sectional area of all the legs of the links at a particular cross section;
- s_v is the spacing of the links along the member;
- f_{yv} is the characteristic strength of link reinforcement but not greater than 460 N/mm^2 .

Where links combined with bent-up bars are used for shear reinforcement, not more than 50 % of the shear force $(v + 0.4 - \xi_s v_c)bd$ should be resisted by bent-up bars. These bars should be assumed to form the tension members of one or more single systems of lattice girders in which the concrete forms the compression members. The maximum stress in any bar should be taken as $0.87 f_y$. The shear resistance at any vertical section should be taken as the sum of the vertical components of the tension and compression forces cut by the section. Bars should be checked for anchorage (see 5.8.6.3) and bearing (see 5.8.6.8).

Table 8 — Ultimate shear stress in concrete, v_c

$\frac{100A_s}{bd}$	Concrete grade			
	20	25	30	40 or more
	N/mm^2	N/mm^2	N/mm^2	N/mm^2
≤ 0.15	0.31	0.34	0.36	0.39
0.25	0.37	0.40	0.42	0.47
0.50	0.47	0.50	0.53	0.59
1.00	0.59	0.63	0.67	0.74
2.00	0.74	0.80	0.85	0.93
≥ 3.00	0.85	0.91	0.97	1.06

NOTE $b = b_s$ for punching shear cases (see Figure 5).

Table 8 is derived from the following relationship:

$$v_c = \frac{0.27}{\gamma_m} \left(\frac{100A_s}{b_w d} \right)^{1/3} (f_{cu})^{1/3}$$

where γ_m is taken as 1.25 and f_{cu} should not exceed 40.

The term A_s in Table 8 is that area of longitudinal reinforcement which continues at least a distance equal to the effective depth beyond the section being considered, except at supports where the full area of tension reinforcement may be used provided the recommendations of 5.8.7 are met.

Where both top and bottom reinforcement is provided the area of A_s used should be that which is in tension under the loading which produces the shear force being considered.

Table 9 — Values of ξ_s

Effective depth, d	ξ_s
2 000 or more	0.70
1 500	0.75
1 000	0.85
500	1.00
400	1.05
300	1.15
250	1.20
200	1.25
150	1.35
≤ 100	1.50

Table 9 is derived from the following relationship:

$$\xi_s = (500/d)^{1/4} \text{ or } 0.70, \text{ whichever is the greater.}$$

The spacing of the legs of links, in the direction of the span and at right-angles to it, should not exceed $0.75d$.

At any cross section additional longitudinal reinforcement, A_{sa} , is required in the tensile zone (in excess of that required to resist bonding) such that:

$$A_{sa} \geq \frac{V}{2(0.87f_y)}$$

where

A_{sa} is the area of effectively anchored additional longitudinal tensile reinforcement (see 5.8.7);

f_y is the characteristic strength of the reinforcement;

V is the shear force due to ultimate loads at the point considered.

5.3.3.3 Enhanced shear strength of sections close to supports. An enhancement of shear strength may be allowed for sections within a distance $a_v < 2d$ from the face of a support, front edge of a rigid bearing or centre line of a flexible bearing.

This enhancement should take the form of an increase in the allowable shear stress, $\xi_s v_c$ to $\xi_s v_c \times 2d/a_v$, but should not exceed $0.75\sqrt{f_{cu}}$ or 4.75 N/mm^2 , whichever is the lesser.

Where this enhancement is used the main reinforcement at the section considered should continue to the support and be provided with an anchorage equivalent to 20 times the bar size.

5.3.3.4 Bottom loaded beams. Where load is applied near the bottom of a section, sufficient vertical reinforcement to carry the load to the top of the section should be provided in addition to any reinforcement required to resist shear.

5.3.4 Torsion

5.3.4.1 General. Torsion does not usually decide the dimension of members, therefore torsion design should be carried out as a check, after the flexural design. This is particularly relevant to some members in which the maximum torsional moment does not occur under the same loading as the maximum flexural moment. In such circumstances reinforcement in excess of that required for flexure and other forces may be used in torsion.

5.3.4.2 Torsionless systems. In general, where the torsional resistance or stiffness of members has not been taken into account in the analysis of the structure, no specific calculations for torsion will be necessary, adequate control of any torsional cracking being provided by the required nominal shear reinforcement. However, in applying this clause it is essential that sound engineering judgement has shown that torsion plays only a minor role in the behaviour of the structure, otherwise torsional stiffness should be used in analysis.

5.3.4.3 Stresses and reinforcement. Where torsion in a section increases substantially the shear stresses, the torsional shear stress should be calculated assuming a plastic stress distribution.

Where the torsional shear stress, v_t , exceeds the value v_{tmin} from Table 10, reinforcement should be provided. In no case should the sum of the shear stresses resulting from shear force and torsion ($v + v_t$) exceed the value of the ultimate shear stress, v_{tu} , from Table 10 nor, in the case of small sections ($y_1 < 550 \text{ mm}$), should the torsional shear stress, v_t , exceed $v_{tu}y_1/550$, where y_1 is the larger centre line dimension of a link.

Torsion reinforcement should consist of rectangular closed links in accordance with 5.8.6.5 together with longitudinal reinforcement.

It should be calculated assuming that the closed links form a thin-walled tube, the shear stresses in which are balanced by longitudinal and transverse forces provided by the resistance of the reinforcement.

This reinforcement is additional to any requirements for shear or bending.

5.3.4.4 Treatment of various cross sections

a) *Box sections.* The torsional shear stress should be calculated as:

$$v_t = \frac{T}{2h_{wo}A_o} \quad \text{equation 9}$$

where

h_{wo} is the wall thickness where the stress is determined;

A_o is the area enclosed by the median wall line.

Torsion reinforcement should be provided such that:

$$\frac{A_{st}}{s_v} \geq \frac{T}{2A_o(0.87f_{yv})} \quad \text{equation 10}$$

$$\frac{A_{sL}}{s_L} \geq \frac{A_{st}}{s_v} \left(\frac{f_{yv}}{f_{yL}} \right) \quad \text{equation 11}$$

where

- T is the torsional moment due to the ultimate loads;
- A_{st} is the area of one leg of a closed link at a section;
- A_{sL} is the area of one bar of longitudinal reinforcement;
- f_{yv} is the characteristic strength of the links;
- f_{yL} is the characteristic strength of the longitudinal reinforcement;
- s_v is the spacing of the links along the member;
- s_L is the spacing of the longitudinal reinforcement.

In equations 10 and 11, f_{yv} and f_{yL} should not be taken as greater than 460 N/mm².

b) *Rectangular sections.* The torsional stresses should be calculated from the equation:

$$v_t = \frac{2T}{h_{min}^2 \left(h_{max} - \frac{h_{min}}{3} \right)} \quad \text{equation 9(a)}$$

where

- h_{min} is the smaller dimension of the section;
- h_{max} is the larger dimension of the section.

Torsion reinforcement should be provided such that:

$$\frac{A_{st}}{s_v} \geq \frac{T}{1.6x_1y_1(0.87f_{yv})} \quad \text{equation 10(a)}$$

where

- x_1 is the smaller centre line dimension of the links;
- y_1 is the larger centre line dimension of the links;

and A_{sL} satisfies equation 11 with the value of A_{st} calculated as in equation 10(a).

c) T , L and I sections. Such sections should be divided into component rectangles for purposes of torsional design. This should be done in such a way as to maximize the function $\Sigma(h_{max}h_{min}^3)$, where h_{max} and h_{min} are the larger and smaller dimensions of each component rectangle. Each rectangle should then be considered subject to a torque:

$$\frac{T(h_{max}h_{min}^3)}{\Sigma(h_{max}h_{min}^3)}$$

Reinforcement should be so detailed as to tie the individual rectangles together. Where the torsional shear stress in a minor rectangle is less than v_{tmin} , no torsion reinforcement need be provided in that rectangle.

5.3.4.5 Detailing. Care should be taken in detailing to prevent the diagonal compressive forces in adjacent faces of a beam spalling the section corner. The closed links should be detailed to have minimum cover, and a pitch less than the smallest of $(x_1 + y_1)/4$, 16 longitudinal corner bar diameters or 300 mm. The longitudinal reinforcement should be positioned uniformly and such that there is a bar at each corner of the links. The diameter of the corner bars should be not less than the diameter of the links.

In detailing the longitudinal reinforcement to cater for torsional stresses account may be taken of those areas of the cross section subjected to simultaneous flexural compressive stresses, and a lesser amount of reinforcement provided. The reduction in the amount of reinforcement in the compressive zone may be taken as:

Reduction of steel area =

$$\frac{f_{cav} (\text{Area of section subject to flexural compression})}{0.87f_{yL}}$$

where f_{cav} is the average compressive stress in the flexural compressive zone.

In the case of beams, the depth of the compression zone used to calculate the area of section subject to flexural compression should be taken as twice the cover to the closed links.

The area of either the links or the longitudinal reinforcement may be reduced by 20 % provided that the product

$$\frac{A_{st}}{s_v} \times \frac{A_{sL}}{s_L}$$

remains unchanged.

Table 10 — Ultimate torsion shear stress

	Concrete grade			
	20	25	30	40 or more
v_{tmin}	N/mm ² 0.30	N/mm ² 0.33	N/mm ² 0.37	N/mm ² 0.42
v_{tu}	3.35	3.75	4.10	4.75

5.3.5 Longitudinal shear. For flanged beams, the longitudinal shear resistance across vertical sections of the flange which may be critical should be checked in accordance with 7.4.2.3.

5.3.6 Deflection in beams. Deflections may be calculated in accordance with clause 4.

5.3.7 Crack control in beams. Flexural cracking in beams should be controlled by checking crack widths in accordance with 5.8.8.2.

5.4 Slabs

5.4.1 Moments and shear forces in slabs.

Moments and shear forces in slab bridges and in the top slabs of beam and slab, voided slab and box beam bridges may be obtained from a general elastic analysis, or such particular elastic analyses as those due to Westergaard or Pucher; alternatively, Johansen's yield line method may be used to obtain required ultimate moments of resistance provided that the recommendations of 4.4.3.1 are met.

The effective spans should be in accordance with 5.3.1.1.

5.4.2 Resistance moments of slabs. The ultimate resistance moment in a reinforcement direction may be determined by the methods given in 5.3.2. If reinforcement is being provided to resist a combination of two bending moments and a twisting moment at a point in a slab, allowance should be made for the fact that the principal moment and reinforcement directions do not generally coincide. Allowance can be made by calculating moments of resistance in the reinforcement directions, such that adequate strength is provided in all directions.

In voided slabs, the stresses in the transverse flexural reinforcement due to transverse shear effects should be calculated by an appropriate analysis (e.g. an analysis based on the assumption that the transverse section acts as a Vierendeel frame).

5.4.3 Resistance to in-plane forces. If reinforcement is to be provided to resist a combination of in-plane direct and shear forces at a point in a slab, allowance should be made for the fact that the principal stress and reinforcement directions do not generally coincide. Such allowance can be made by calculating required forces in the reinforcement directions, such that adequate strength is provided in all directions.

5.4.4 Shear resistance of slabs

5.4.4.1 Shear stress in solid slabs: general. The shear stress, v , at any cross section in a solid slab, should be calculated from:

$$v = \frac{V}{bd} \quad \text{equation 12}$$

where

- V is the shear force due to ultimate loads;
- b is the width of slab under consideration;
- d is the effective depth to tension reinforcement.

No shear reinforcement is required when the stress, v , is less than $\xi_s v_c$, where ξ_s has the value shown in Table 9 and v_c is obtained from Table 8.

The shear stress, v , in a solid slab less than 200 mm thick should not exceed $\xi_s v_c$.

In solid slabs at least 200 mm thick, when v is greater than $\xi_s v_c$, shear reinforcement should be provided as for a beam (see 5.3.3.2) except that the space between links may be increased to d .

The maximum shear stress due to ultimate loads should not exceed the appropriate value given in 5.3.3.1 for a beam.

5.4.4.2 Shear stresses in solid slabs under concentrated loads (including wheel loads). When considering this clause the dispersal of wheel loads allowed in Part 2 should be taken to the top surface of the concrete slab only and not down to the neutral axis.

The critical section for calculating shear should be taken on a perimeter $1.5d$ from the boundary of the loaded area, as shown in Figure 5(a) where d is the effective depth to the flexural tension reinforcement. Where concentrated loads occur on a cantilever slab or near unsupported edges, the relevant portions of the critical section should be taken as the worst case from (a), (b) or (c) of Figure 5. For a group of concentrated loads, adjacent loaded areas should be considered singly and in combination using the preceding recommendations.

No shear reinforcement is required when the ultimate shear force, V , due to concentrated loads, is less than the ultimate shear resistance of the concrete, V_c , at the critical section, as given in Figure 5.

The overall ultimate shear resistance at the critical section should be taken as the sum of the shear resistances of each portion of the critical section. The value of $100A_s/(b_s d)$ to be used in Table 8 for each portion should be derived by considering the effectively anchored flexural tensile reinforcement associated with each portion as shown in Figure 5.

In solid slabs at least 200 mm thick, where V lies between V_c and the maximum shear resistance based on that allowed for a beam in 5.3.3.1, an area of shear reinforcement should be provided on the critical perimeter and a similar amount on a parallel perimeter at a distance of $0.75d$ inside it, such that:

$$0.4 \Sigma bd \leq \Sigma A_{sv} (0.87f_{yv}) \geq V - c \quad \text{equation 13}$$

where

Σbd is the area of the critical section;

ΣA_{sv} is the area of shear reinforcement;

f_{yv} is the characteristic strength of the shear reinforcement, which should be taken as not greater than 460 N/mm^2 .

	(a) Load at middle of slab	(b) Load at edge of slab	(c) Load at corner of cantilever slab	
Critical section for calculating shear resistance V_c [Critical sections (a), (b) and (c)(i) are assumed to have squared corners for rectangular and circular loaded areas]			(i)	(ii)
Idealized mode of failure (only tension reinforcement shown)				
Parameters used to derive v_c from Table 8 for each portion of critical section NOTE A_s should include only tensile reinforcement which is effectively anchored				<p>The ratio of reinforcement $\frac{100 A_s}{b_s d}$ should be taken as the average of the ratios of reinforcement in the two directions</p>
Shear resistance V_c at critical section	$\Sigma \xi_s v_c b d$ for 4 critical portions	$0.8 \Sigma \xi_s v_c b d$ for 3 critical portions	$0.8 \Sigma \xi_s v_c b d$ for 2 critical portions	$\frac{[\xi_{sx} + \xi_{sy}]}{2} \cdot v_c b \frac{[d_x + d_y]}{2}$

Figure 5 — Parameters for shear in solid slabs under concentrated loads

The overall ultimate shear resistance should be calculated on perimeters progressively $0.75d$ out from the critical perimeter and, if the resistance continues to be exceeded, further shear reinforcement should be provided on each perimeter in accordance with equation 13, substituting the appropriate values for V and Σbd . Shear reinforcement should be considered effective only in those places where the slab depth is greater than or equal to 200 mm. Shear reinforcement may be in the form of vertical or inclined links anchored at both ends by passing round the main reinforcement. Links should be spaced no further apart than $0.75d$ and, if inclined links are used, the area of shear reinforcement should be adjusted to give the equivalent shear resistance.

When openings in slabs and footings (see Figure 6) are located at a distance less than $6d$ from the edge of a concentrated load or reaction, then that part of the periphery of the critical section which is enclosed by radial projections of the openings to the centroid of the loaded area should be considered ineffective.

Where one hole is adjacent to the column and its greatest width is less than one-quarter of the column side or one-half of the slab depth, whichever is the lesser, its presence may be ignored.

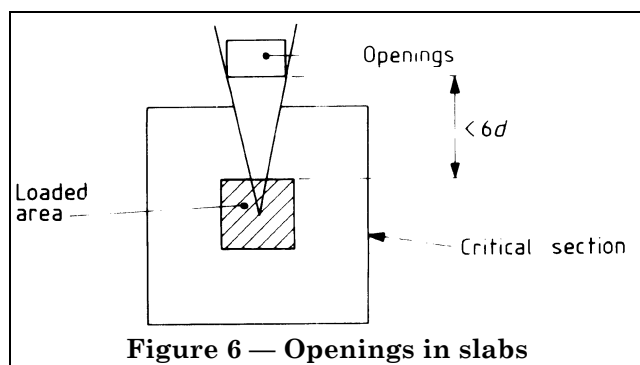

Figure 6 — Openings in slabs

5.4.4.3 Shear in voided slabs. The longitudinal ribs between the voids should be designed as beams (see 5.3.3) for the shear forces in the longitudinal direction including any shear due to torsional effects.

The top and bottom flanges should be designed as solid slabs (see 5.4.4.1), each to carry a part of the global transverse shear forces and any shear forces due to torsional effects proportional to the flange thicknesses. The top flange of a rectangular voided slab should be designed to resist the punching effect due to wheel loads (see 5.4.4.2). Where wheel loads may punch through the slab as a whole, this should also be checked.

5.4.5 Deflection of slabs. Deflections may be calculated in accordance With clause 4.

5.4.6 Crack control in slabs. Cracking in slabs should be checked in accordance with 5.8.8.2.

5.5 Columns

5.5.1 General

5.5.1.1 Definitions. A reinforced concrete column is a compression member whose greater lateral dimension is less than or equal to four times its lesser lateral dimension, and in which the reinforcement is taken into account when considering its strength.

A column should be considered as short if the ratio l_e/h in each plane of buckling is less than 12, where:

- l_e is the effective height in the plane of buckling under consideration;
- h is the depth of the cross section in the plane of buckling under consideration.

It should otherwise be considered as slender.

5.5.1.2 Effective height of a column. The effective height, l_e , in a given plane may be obtained from Table 11 where l_o is the clear height between end restraints.

The values given in Table 11 are based on the following assumptions:

- a) rotational restraint is at least $4(EI)_c/l_o$ for cases 1, 2 and 4 to 6 and $8(EI)_c/l_o$ for case 7, $(EI)_c$ being the flexural rigidity of the column cross section;
- b) lateral and rotational rigidity of elastomeric bearings are zero.

Where a more accurate evaluation of the effective height is required or where the end stiffness values are less than those values given in a), the effective heights should be derived from first principles.

The accommodation of movements and the method of articulation chosen for the bridge will influence the degree of restraint developed for columns. These factors should be assessed as accurately as possible using engineering principles based on elastic theory and taking into account all relevant factors such as foundation flexibility, type of bearings, articulation system, etc.

5.5.1.3 Slenderness limits for columns. In each plane of buckling, the ratio l_e/h should not exceed 40, except that where the column is not restrained in position at one end, the ratio l_e/h should not exceed 30; l_e and h are as defined in 5.5.1.1.

5.5.1.4 Assessment of strength. Subclauses 5.5.2 to 5.5.7 give methods, for assessing the strength of columns at the ultimate limit state, which are based on a number of assumptions. These methods may be used provided the assumptions are realized for the case being considered and the effective height is determined accurately. In addition, for columns subject to applied bending moments the serviceability limit state for cracking given in 4.1.1.1 a) should be met.

5.5.2 Moments and forces in columns. The moments, shear forces and axial forces in a column should be determined in accordance with 4.4, except that if the column is slender the moments induced by deflection should be considered. An allowance for these additional moments is made in the design recommendations for slender columns which follow, and the bases or other members connected to the ends of such columns should also be designed to resist these additional moments.

In columns with end moments it is generally necessary to consider the maximum and minimum ratios of moment to axial load in designing reinforcement areas and concrete sections.

5.5.3 Short columns subject to axial load and bending about the minor axis

5.5.3.1 General. A short column should be designed for the ultimate limit state in accordance with the following recommendations provided that the moment at any cross section has been increased by that moment produced by considering the ultimate axial load as acting at an eccentricity equal to 0.05 times the overall depth of the cross section in the plane of bending, but not more than 20 mm. This is a nominal allowance for eccentricity due to construction tolerances.

5.5.3.2 Analysis of sections. When analysing a column cross section to determine its ultimate resistance to moment and axial load, the following assumptions should be made.

- a) The strain distribution in the concrete in compression and the compressive and tensile strains in the reinforcement are derived from the assumption that plane sections remain plane.
- b) The stresses in the concrete in compression are either derived from the stress-strain curve in Figure 1 with $\gamma_m = 1.50$, or taken as equal to $0.4f_{cu}$ over the whole compression zone where this is rectangular or circular. In both cases, the concrete strain at the outermost compression fibre at failure is taken as 0.0035.
- c) The tensile strength of the concrete is ignored.
- d) The stresses in the reinforcement are derived from the stress-strain curves in Figure 2 with $\gamma_m = 1.15$.

For rectangular and circular columns the following design methods, based on the preceding assumptions, may be used. For other column shapes, design methods should be derived from first principles using the preceding assumptions.

5.5.3.3 Design charts for rectangular and circular columns. The design charts that form Part 3 of BS 8110 include charts (based on Figure 1 and Figure 2 and the assumptions in 5.5.3.2) which may be used for the design of rectangular and circular column sections having a symmetrical arrangement of reinforcement.

Table 11 — Effective height, l_e , for columns

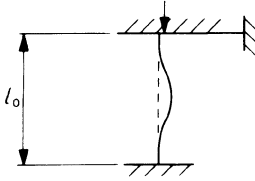
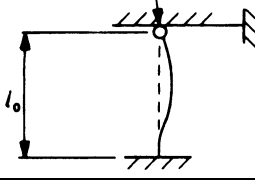
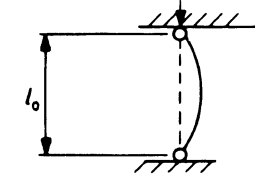
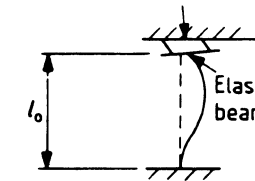
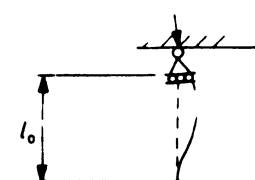
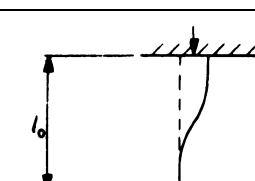
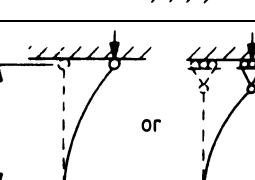
Case	Idealized column and buckling mode	Restraints			Effective height, l_e
		Location	Position	Rotation	
1		Top	Full	Full ^a	0.70 l_0
		Bottom	Full	Full ^a	
2		Top	Full	None	0.85 l_0
		Bottom	Full	Full ^a	
3		Top	Full	None	1.0 l_0
		Bottom	Full	None	
4		Top	None ^a	None ^a	1.3 l_0
		Bottom	Full	Full ^a	
5		Top	None	None	1.4 l_0
		Bottom	Full	Full ^a	
6		Top	None	Full ^a	1.5 l_0
		Bottom	Full	Full ^a	
7		Top	None	None	2.3 l_0
		Bottom	Full	Full ^a	

^a Assumed value (see 5.5.1.2).

5.5.3.4 Design formulae for rectangular columns.

The following formulae (based on a concrete stress of $0.4f_{cu}$ over the whole compression zone and the assumptions in 5.5.3.2) may be used for the design of a rectangular column having longitudinal reinforcement in the two faces parallel to the axis of bending, whether that reinforcement is symmetrical or not. Both the ultimate axial load, N , and the ultimate moment, M , should not exceed the values of N_u and M_u given by equations 14 and 15 for the appropriate value of d_c .

$$N_u = 0.4f_{cu}bd_c + f_{yc}A'_{s1} + f_{s2}A_{s2} \quad \text{equation 14}$$

$$M_u = 0.2f_{cu}bd_c(h - d_c) + f_{yc}A'_{s1}\left(\frac{h}{2} - d'\right) - f_{s2}A_{s2}\left(\frac{h}{2} - d_2\right) \quad \text{equation 15}$$

where

N is the ultimate axial load applied on the section considered;

M is the moment applied about the axis considered due to ultimate loads including the nominal allowance for construction tolerances (see 5.5.3);

N_u and M_u are the ultimate axial load and bending capacities of the section for the particular value of d_c assumed;

f_{cu} is the characteristic cube strength of the concrete;

b is the breadth of the section;

d_c is the depth of concrete in compression assumed subject to a minimum value of $2d'$;

f_{yc} is the design compressive strength of the reinforcement (in N/mm^2), taken as:

$$\frac{f_y}{\gamma_m + \frac{f_y}{2000}} ;$$

A'_{s1} is the area of compression reinforcement in the more highly compressed face;

f_{s2} is the stress in the reinforcement in the other face, derived from Figure 2 and taken as negative if tensile;

A_{s2} is the area of reinforcement in the other face which may be considered as being:

- 1) in compression,
- 2) inactive, or
- 3) in tension,

as the resultant eccentricity of load increases and d_c decreases from h to $2d'$;

h is the overall depth of the section in the plane of bending;

d' is the depth from the surface to the reinforcement in the more highly compressed face;

d_2 is the depth from the surface to the reinforcement in the other face.

5.5.3.5 Simplified design formulae for rectangular columns. The following simplified formulae may be used, as appropriate, for the design of rectangular column having longitudinal reinforcement in the two faces parallel to the axis of bending, whether that reinforcement is symmetrical or not.

a) Where the resultant eccentricity, $e = M/N$, does not exceed $(h/2 - d')$ and where the ultimate axial load, N , does not exceed $0.45f_{cu}b(h - 2e)$, only nominal reinforcement is required (see 5.8.4.1 for minimum provision of longitudinal reinforcement), where M , N , h , d' , f_{cu} and b are as defined in 5.5.3.4.

b) Where the resultant eccentricity is not less than $(h/2 - d_2)$ the axial load may be ignored and the column section designed to resist an increased moment:

$$M_a = M + N\left(\frac{h}{2} - d_2\right)$$

where M , N , h and d_2 are as defined in 5.5.3.4.

The area of tension reinforcement necessary to provide resistance to this increased moment may be reduced by the amount $N/0.87f_y$.

5.5.4 Short columns subject to axial load and either bending about the major axis or biaxial bending. The moment about each axis due to ultimate loads should be increased by that moment produced by considering the ultimate axial load as acting at an eccentricity equal to 0.03 times the overall depth of the cross section in the appropriate plane of bending, but not more than 20 mm. This is a nominal allowance for eccentricity due to construction tolerances.

For square, rectangular and circular columns having a symmetrical arrangement of reinforcement about each axis, the section may be analysed for axial load and bending about each axis in accordance with any one of the methods of design given in 5.5.3.2, 5.5.3.3 or 5.5.3.4 such that:

$$\left(\frac{M_x}{M_{ux}}\right)^{\alpha_n} + \left(\frac{M_y}{M_{uy}}\right)^{\alpha_n} \leq 1.0 \quad \text{equation 16}$$

where

M_x and M_y are the moments about the major x-x axis and minor y-y axis respectively due to ultimate loads, including the nominal allowance for construction tolerances given in the preceding paragraph;

M_{ux} is the ultimate moment capacity about the major x-x axis assuming an ultimate axial load capacity, N_u , not less than the value of the ultimate axial load, N ;

M_{uy} is the ultimate moment capacity about the minor y-y axis assuming an ultimate axial load capacity, N_u , not less than the value of the ultimate axial load, N ;

α_n is related to N/N_{uz} as given in Table 12, where N_{uz} is the axial loading capacity of a column ignoring all bending, taken as:

$$N_{uz} = 0.45f_{cu}A_c + f_{yc}A_{sc} \quad \text{equation 17}$$

where

f_{cu} and f_{yc} are as defined in 5.5.3.4;

A_c is the area of concrete;

A_{sc} is the area of longitudinal reinforcement.

For other column sections, design should be in accordance with 5.5.3.2.

Table 12 — Relationship of N/N_{uz} to α_n

N/N_{uz}	α_n
≤ 0.2	1.0
0.4	1.33
0.6	1.67
≥ 0.8	2.0

5.5.5 Slender columns

5.5.5.1 General. A cross section of a slender column may be designed by the methods given for a short column (see 5.5.3 and 5.5.4) but, in the design, account should be taken of the additional moments induced in the column by its deflection. For slender columns of constant rectangular or circular cross section having a symmetrical arrangement of reinforcement, the column should be designed to resist the ultimate axial load, N , together with the moments M_{tx} and M_{ty} derived in accordance with 5.5.5.4. Alternatively, the simplified formulae given in 5.5.5.2 and 5.5.5.3 may be used where appropriate; in this case the moment due to ultimate loads need not be increased by the nominal allowance for construction tolerances given in 5.5.3. It will be sufficient to limit the minimum value of moment to not less than the nominal allowance given in 5.5.3.

5.5.5.2 Slender columns bent about a minor axis. A slender column of constant cross section bent about the minor y-y axis should be designed for its ultimate axial load, N , together with the moment M_{ty} given by:

$$M_{ty} = M_{iy} + \frac{Nh_x}{1750} \left(\frac{l_e}{h_x}\right)^2 \left(1 - \frac{0.0035l_e}{h_x}\right) \quad \text{equation 18}$$

where

M_{iy} is the initial moment due to ultimate loads, but not less than that corresponding to the nominal allowance for construction tolerances as given in 5.5.3;

h_x is the overall depth of the cross section in the plane of bending M_{iy} ;

l_e is the effective height either in the plane of bending or in the plane at right-angles, whichever is greater.

For a column fixed in position at both ends where no transverse loads occur in its height the value of M_{iy} may be reduced to:

$$M_{iy} = 0.4M_1 + 0.6M_2 \quad \text{equation 19}$$

where

M_1 is the smaller initial end moment due to ultimate loads (assumed negative if the column is bent in double curvature);

M_2 is the larger initial end moment due to ultimate loads (assumed positive).

In no case, however, should M_{iy} be taken as less than $0.4M_2$ or such that M_{ty} is less than M_2 .

5.5.5.3 Slender columns bent about a major axis.

When the overall depth of its cross section, h_y , is less than three times the width, h_x , a slender column bent about the major x-x axis should be designed for its ultimate axial load, N , together with the moment M_{tx} given by:

$$M_{tx} = M_{ix} + \frac{Nh_y}{1750} \left(\frac{l_e}{h_x} \right)^2 \left(1 - \frac{0.0035l_e}{h_x} \right) \quad \text{equation 20}$$

where

- l_e and h_x are as defined in 5.5.5.2;
- M_{ix} is the initial moment due to ultimate loads, but not less than that corresponding to the nominal allowance for construction tolerances as given in 5.5.3;
- h_y is the overall depth of the cross section in the plane of bending M_{ix} .

Where h_y is equal to or greater than three times h_x , the column should be considered as biaxially loaded with a nominal initial moment about the minor axis.

5.5.5.4 Slender columns bent about both axes. A slender column bent about both axes should be designed for its ultimate axial load, N , together with the moments M_{tx} about its major axis and M_{ty} about its minor axis, given by:

$$M_{tx} = M_{ix} + \frac{Nh_y}{1750} \left(\frac{l_{ex}}{h_y} \right)^2 \left(1 - \frac{0.0035l_{ex}}{h_y} \right) \quad \text{equation 21}$$

$$M_{ty} = M_{iy} + \frac{Nh_x}{1750} \left(\frac{l_{ey}}{h_x} \right)^2 \left(1 - \frac{0.0035l_{ey}}{h_x} \right) \quad \text{equation 22}$$

where

- h_x and h_y are as defined in 5.5.5.2 and 5.5.5.3 respectively;
- M_{ix} is the initial moment due to ultimate loads about the x-x axis, including the nominal allowance for construction tolerances (see 5.5.4);
- M_{iy} is the initial moment due to ultimate loads about the y-y axis, including the nominal allowance for construction tolerances (see 5.5.4);
- l_{ex} is the effective height in respect of bending about the major axis;
- l_{ey} is the effective height in respect of bending about the minor axis.

5.5.6 Shear resistance of columns. A column subject to uniaxial shear due to ultimate loads should be designed in accordance with 5.3.3 except that the ultimate shear stress, $\xi_s v_c$, obtained from Table 8 and Table 9 may be multiplied by:

$$1 + \frac{0.05N}{A_c}$$

where

N is the ultimate axial load (in newtons);

A_c is the area of the entire concrete section (in mm²).

A column subject to biaxial shear due to ultimate loads should be designed such that:

$$\frac{V_x}{V_{ux}} + \frac{V_y}{V_{uy}} \leq 1.0$$

where

V_x and V_y are the applied shears due to ultimate loads for the x-x axis and y-y axis respectively;

V_{ux} and V_{uy} are the corresponding ultimate shear capacities of the concrete and link reinforcement for the x-x and y-y axis respectively derived in accordance with this clause.

5.5.7 Crack control in columns. A column subjected to bending should be considered as a beam for the purpose of crack control (see 5.8.8.2).

5.6 Reinforced concrete walls**5.6.1 General**

5.6.1.1 Definition. A reinforced wall is a vertical load-bearing concrete member whose greater lateral dimension is more than four times its lesser lateral dimension, and in which the reinforcement is taken into account when considering its strength.

Retaining walls, wing walls, abutments, piers and other similar elements subjected principally to bending moments, and where the ultimate axial load is less than $0.1 f_{cu} A_c$, should be treated as cantilever slabs and designed in accordance with 5.4. In other cases, this clause applies.

A reinforced wall should be considered as either short or slender. In a similar manner to columns, a wall may be considered as short where the ratio of its effective height to its thickness does not exceed 12. It should otherwise be considered as slender.

5.6.1.2 Limits to slenderness. The slenderness ratio is the ratio of the effective height of the wall to its thickness. The effective height should be obtained from Table 11. When the wall is restrained in position at both ends and the reinforcement complies with the recommendations of 5.8.4, the slenderness ratio should not exceed 40 unless more than 1 % of vertical reinforcement is provided, when the slenderness ratio may be up to 45.

When the wall is not restrained in position at one end the slenderness ratio should not exceed 30.

5.6.2 Forces and moments in reinforced concrete walls. Forces and moments should be calculated in accordance with 4.4 except that, if the wall is slender, the moments induced by deflection should also be considered. The distribution of axial and horizontal forces along a wall from the loads on the superstructure should be determined by analysis and their points of application decided by the nature and location of the bearings. For walls fixed to the deck, the moments should similarly be determined by elastic analysis.

The moment/unit length in the direction at right-angles to a wall should be taken as not less than $0.05n_w h$, where n_w is the ultimate axial load per unit length and h is the thickness of the wall. Moments in the plane of a wall can be calculated from statics for the most severe positioning of the relevant loads.

Where the axial load is non-uniform, consideration should be given to deep beam effects and the distribution of axial loads per unit length of wall.

It will generally be necessary to consider the maximum and minimum ratios of moment to axial load in designing reinforcement areas and concrete sections.

5.6.3 Short reinforced walls resisting moments and axial forces. The cross section of the various portions of the wall should be designed to resist the appropriate ultimate axial load and the transverse moment per unit length calculated in accordance with 5.6.2. The assumptions made when analysing beam sections (see 5.3.2.1) apply and also when the wall is subject to significant bending only in the plane of the wall.

When the wall is subjected to significant bending both in the plane of the wall and at right-angles to it, consideration should be given first to bending in the plane of the wall in order to establish a distribution of tension and compression along the length of the wall. The resulting tension and compression should then be combined with the compression due to the ultimate axial load to determine the combined axial load per unit length of wall. This may be done by an elastic analysis assuming a linear distribution along the wall.

The bending moment at right-angles to the wall should then be considered and the section checked for this moment and the resulting compression or tension per unit length at various points along the wall length, using the assumptions of 5.3.2.1.

5.6.4 Slender reinforced walls. The distribution of axial load along a slender reinforced wall should be determined as for a short wall. The critical portion of wall should then be considered as a slender column of unit width and designed as such in accordance with 5.5.5.

5.6.5 Shear resistance of reinforced walls. A wall subject to uniaxial shear due to ultimate loads should be designed in accordance with 5.4.4.1 except that the ultimate shear stress, $\xi_s v_c$, obtained from Table 9 and Table 8 may be multiplied by:

$$1 + \frac{0.05N}{A_c}$$

where

N is the ultimate axial load (in newtons);

A_c is the area of the entire concrete section (in mm^2).

A wall subject to biaxial shear due to ultimate loads should be designed such that:

$$\frac{V_x}{V_{ux}} + \frac{V_y}{V_{uy}} \leq 1.0$$

where

V_x and V_y are the applied shears due to ultimate loads for the x-x axis and y-y axis respectively;

V_{ux} and V_{uy} are the corresponding ultimate shear capacities of the concrete and link reinforcement for the x-x axis and y-y axis respectively, derived in accordance with this clause.

5.6.6 Deflection of reinforced walls. The deflection of a reinforced concrete wall will be within acceptable limits if the recommendations given in 5.6.1 to 5.6.5 have been followed.

5.6.7 Crack control in reinforced walls. Where walls are subject to bending, design crack widths should be calculated in accordance with 5.8.8.2.

5.7 Bases

5.7.1 General. Where pockets are left for precast members allowance should be made, when computing the flexural and shear strength of base sections, for the effects of these pockets unless they are to be subsequently grouted up using a cement mortar of compressive strength not less than that of the concrete in the base.

5.7.2 Moments and forces in bases. Except where the reactions to the applied loads and moments are derived by more accurate methods, e.g. an elastic analysis of a pile group or the application of established principles of soil mechanics, the following assumptions should be made.

- a) Where the base is axially loaded, the reactions to ultimate loads are uniformly distributed per unit area or per pile.
- b) Where the base is eccentrically loaded, the reactions vary linearly across the base. For columns and walls restrained in direction at the base, the moment transferred to the base should be obtained from 5.5.

The critical section in the design of an isolated base may be taken as the face of the column or wall.

The moment at any vertical section passing completely across a base should be taken as that due to all external ultimate loads and reactions on one side of that section. No redistribution of moments should be made.

5.7.3 Design of bases

5.7.3.1 Resistance to bending. Bases should be designed as “beam-and-slab” or “flat-slab” as appropriate. Beam-and-slab bases should be designed in accordance with 5.3.

Flat-slab sections should be designed to resist the total moments and shears at the sections considered.

Where the width of the section considered is less than or equal to $1.5(b_{\text{col}} + 3d)$, where b_{col} is the width of the column and d is the effective depth, to the tension reinforcement, of the base, reinforcement should be distributed evenly across the width of the section considered. For greater widths, two-thirds of the area of reinforcement should be concentrated on a width of $(b_{\text{col}} + 3d)$ centred on the column.

Pile caps may be designed either by bending theory or by truss analogy taking the apex of the truss at the centre of the loaded area and the corners of the base of the truss at the intersections of the centre lines of the piles with the tensile reinforcement.

In pile caps designed as beams the reinforcement should be uniformly distributed across any given section. In pile caps designed by truss analogy 80 % of the reinforcement should be concentrated in strips linking the pile heads and the remainder uniformly distributed throughout the pile cap.

5.7.3.2 Shear. The design shear is the algebraic sum of all ultimate vertical loads acting on one side of or outside the periphery of the critical section. The shear strength of flat-slab bases in the vicinity of concentrated loads is governed by the more severe of the following two conditions.

- a) Shear along a vertical section extending across the full width of the base, at a distance equal to the effective depth from the face of the loaded area. The recommendations of 5.4.4.1 apply.
- b) Punching shear around the loaded area, where the recommendations of 5.4.4.2 apply.

The shear strength of pile caps is governed by the more severe of the following two conditions.

- 1) Shear along any vertical section extending across the full width of the cap. The recommendations of 5.4.4.1 apply except that over portions of the section where the flexural reinforcement is fully anchored by passing across the head of a pile, the allowable ultimate shear stress may be increased to $(2d/a_v) \xi_s v_c$ where

- a_v is the distance between the face of the column or wall and the critical section;
- d is the effective depth, to tension reinforcement, of the section.

Where a_v is taken to be the distance between the face of the column or wall and the nearer edge of the piles it should be increased by 20 % of the pile diameter. In applying the recommendations of 5.4.4.1 the allowable ultimate shear stress should be taken as the average over the whole section.

- 2) Punching shear around loaded areas, where the recommendations of 5.4.4.2 apply.

5.7.3.3 Bond and anchorage. The recommendations of 5.8.6 apply to reinforcement in bases. The critical sections for local bond are:

- a) the critical sections described in 5.8.6.2;
- b) sections at which the depth changes or any reinforcement stops;
- c) in the vicinity of piles, where all the bending reinforcement required to resist the pile load should be continued to the pile centre line and provided with an anchorage beyond the centre line of 20 bar diameters.

5.7.4 Deflection of bases. The deflection of bases need not be considered.

5.7.5 Crack control in bases. The recommendations of 5.8.8.2 apply as appropriate depending on the type of base and treatment of design (see 5.7.3.1).

5.8 Considerations affecting design details

5.8.1 *Constructional details*

5.8.1.1 *Sizes of members.* When deciding on the nominal overall size of a reinforced concrete member regard should be given to the principles of dimensional coordination. It should be borne in mind that absolute accuracy exists only in theory and that tolerable degrees of inaccuracy have to be accepted in practice. The degree of tolerance should be as large as possible, without rendering the finished structure or any part of it unacceptable for the purpose for which it was intended.

5.8.1.2 *Accuracy of position of reinforcement.* In all normal cases the design may be based on the assumption that the reinforcement is in its nominal position. However, when reinforcement is located in relation to more than one face of a member (e.g. a link in a beam in which the nominal cover for all sides is given) the actual concrete cover on one side may be greater and can be derived from a consideration of:

- a) dimensions and spacing of cover blocks, spacers and/or chairs (including the compressibility of these items and the surfaces they bear on);
- b) stiffness, straightness, and accuracy of cutting, bending and fixing of bars or reinforcement cage;
- c) accuracy of formwork both in dimension and plane (this includes permanent forms such as blinding or brickwork);
- d) the size of the structural part and the relative size of bars or reinforcement cage.

In certain cases where bars or reinforcement cages are positioned accurately on one face of a structural member, this may affect the position of highly stressed reinforcement at the opposite face of the member. The consequent possible reduction in effective depth to this reinforcement may exceed the percentage allowed for in the values of the partial safety factors. In the design of a particularly critical member, therefore, appropriate adjustment to the effective depth assumed may be necessary.

5.8.1.3 *Construction joints.* When it is necessary to indicate construction joints on a drawing, careful consideration should be given to their exact location. Construction joints should generally be at right-angles to the direction of the member and should take due account of the shear and other stresses. If special preparation of the joint faces is required it should be specified.

5.8.1.4 *Movement joints.* The location of all movement joints should be clearly indicated on the drawings both for the individual members and for the structure as a whole. In general, movement joints in the structure should pass through the whole structure in one plane. Reference should be made to the relevant bridge authority regarding requirements for the design of joints.

5.8.2 *Concrete cover to reinforcement.* “Nominal” cover is that dimension used in design and indicated on the drawings.

The nominal cover should be not less than the size of the bar or maximum aggregate size, plus 5 mm; in the case of a bundle of bars (see 5.8.8.1), it should be equal to or greater than the size of a single bar of equivalent area plus 5 mm.

The cover to reinforcement should also be determined by considerations of durability under the envisaged conditions of exposure. The nominal cover of dense natural aggregate concrete to all reinforcement, including links, to be shown on the drawings should be not less than the value given in Table 13 for particular grades of concrete and conditions of exposure. In addition, it may be necessary to specify concrete mix details to provide the required durability (see Part 8).

Where a surface treatment such as bush hammering cuts into the face of the concrete, the expected depth of treatment should be added to the nominal cover.

Special care should be exercised for conditions of extreme exposure or where lightweight or porous aggregates are used (see 5.9.2).

5.8.3 *Reinforcement: general considerations*

5.8.3.1 *Groups of bars.* Subject to the reductions in bond stress, bars may be arranged as pairs in contact or in groups of three or four bars bundled in contact.

Bars in a bundle should terminate at different points spaced at least 40 times the bar size apart except for bundles stopping at a support. Laps to one bar at a time in a bundle of three may be made, but they should be so staggered that in any cross section there are no more than four bars in a bundle.

Bundles should not be used in a member without links.

5.8.3.2 *Bar schedule dimensions.* The dimensions of bars shown on the schedule should be the nominal dimensions in accordance with the drawings. In other respects the guidance given in the technical provisions of BS 4466 should be followed.

5.8.4 Minimum areas of reinforcement in members

5.8.4.1 Minimum area of main reinforcement. The area of tension reinforcement in a beam or slab should be not less than 0.15 % of $b_a d$ when using grade 460 reinforcement, or 0.25 % of $b_a d$ when grade 250 reinforcement is used,

where

- b_a is the breadth of section, or average breadth excluding the compression flange for non-rectangular sections;
- d is the effective depth to tension reinforcement.

The minimum number of longitudinal bars provided in a column should be four in rectangular columns and six in circular columns and their size should be not less than 12 mm. The total cross-sectional area of these bars should be not less than 1 % of the cross section of the column or $0.15N/f_y$, whichever is the lesser, where N is the ultimate axial load and f_y is the characteristic strength of the reinforcement.

A wall cannot be considered as a reinforced concrete wall unless the percentage of vertical reinforcement provided is at least 0.4 % of the gross cross-sectional area of the concrete. This vertical reinforcement may be in one or two layers.

5.8.4.2 Minimum area of secondary reinforcement. In the predominantly tensile area of a solid slab or wall the minimum area of secondary reinforcement should be not less than 0.12 % of $b_t d$ when using grade 460 reinforcement, or 0.15 % of $b_t d$ when grade 250 reinforcement is used.

In a solid slab or wall where the main reinforcement is used to resist compression, the area of secondary reinforcement provided should be at least 0.12 % of $b_t d$ in the case of grade 460 reinforcement and 0.15 % of $b_t d$ in the case of grade 250 reinforcement. The diameter should be not less than one-quarter of the size of the vertical bars with horizontal spacing not exceeding 300 mm. This secondary reinforcement should be divided between faces in proportion to the amount of main reinforcement.

In beams where the depth of the side face exceeds 600 mm, longitudinal reinforcement should be provided having an area of at least 0.05 % of $b_t d$ on each face with a spacing not exceeding 300 mm,

- b_t is the breadth of the section;
- d is the effective depth to tension reinforcement.

In a voided slab the amount of transverse reinforcement should exceed the lesser of the following:

- a) in the bottom, or predominantly tensile, flange either $1\,500\text{ mm}^2/\text{m}$ or 1 % of the minimum flange section;
- b) in the top, or predominantly compressive, flange either $1\,000\text{ mm}^2/\text{m}$ or 0.7 % of the minimum flange section.

Additional reinforcement may be required in beams, slabs and walls to control early shrinkage and thermal cracking (see also 5.8.9).

5.8.4.3 Minimum area of links. When, in a beam or column, part or all of the main reinforcement is required to resist compression, links or ties at least one-quarter the size of the largest compression bar should be provided at a maximum spacing of 12 times the size of the smallest compression bar. Links should be so arranged that every corner and alternate bar or group in an outer layer of reinforcement is supported by a link passing round the bar and having an included angle of not more than 135° . All other bars or groups within a compression zone should be within 150 mm of a restrained bar. For circular columns, where the longitudinal reinforcement is located round the periphery of a circle, adequate lateral support is provided by a circular tie passing round the bars or groups.

When the designed percentage of reinforcement in the compression face of a wall or slab exceeds 1 %, links at least 6 mm or one-quarter of the size of the largest compression bar, whichever is the greater, should be provided through the thickness of the member. The spacing of these links should not exceed twice the member thickness in either of the two principal directions of the member and be not greater than 16 times the bar size in the direction of the compressive force.

In all beams shear reinforcement should be provided throughout the span to meet the recommendations given in 5.3.3.

The spacing of links should not exceed 0.75 times the effective depth of the beam, nor should the lateral spacing of the individual legs of the links exceed this figure. Links should enclose all tension reinforcement.

Table 13 — Nominal cover to reinforcement under particular conditions of exposure

Environment	Examples	Nominal cover ^a (mm)			
		Concrete grade			
		25	30	40	50 and over
<i>Extreme</i> Concrete surfaces exposed to: abrasive action by sea water or water with a pH \leq 4.5	Marine structures Parts of structure in contact with moorland water	b	b	65 ^c	55
<i>Very severe</i> Concrete surfaces directly affected by: de-icing salts or sea water spray	Walls and structure supports adjacent to the carriageway Parapet edge beams Concrete adjacent to the sea	b	d	50 ^c	40
<i>Severe</i> Concrete surfaces exposed to: driving rain or alternate wetting and drying	Wall and structure supports remote from the carriageway Bridge deck soffits Buried parts of structures	b	45 ^c	35	30
<i>Moderate</i> Concrete surfaces above ground level and fully sheltered against all of the following: rain, de-icing salts, sea water spray Concrete surfaces permanently saturated by water with a pH $>$ 4.5	Surface protected by bridge deck water-proofing or by permanent formwork Interior surface of pedestrian subways, voided superstructures or cellular abutments Concrete permanently under water	45	35	30	25
^a Actual cover may be up to 5 mm less than nominal cover (see Part 7).					
^b Concrete grade not permitted.					
^c Air entrained concrete should be specified where the surface is liable to freezing whilst wet (see Part 7).					
^d For parapet beams only grade 30 concrete is permitted provided it is air entrained and the nominal cover is 60 mm.					

5.8.5 Maximum areas of reinforcement in

members. In a beam or slab, neither the area of tension reinforcement nor the area of compression reinforcement should exceed 4 % of the gross cross-sectional area of the concrete.

In a column, the percentage of longitudinal reinforcement should not exceed 6 in vertically cast columns or 8 in horizontally cast columns, except that at laps in both types of column the percentage may be 10.

In a wall, the area of vertical reinforcement should not exceed 4 % of the gross cross-sectional area of the concrete.

5.8.6 Bond anchorage and bearing

5.8.6.1 Geometrical classification of deformed bars. For the purposes of this code there are two types of deformed bar, as follows.

Type 1. A plain square twisted bar or a plain chamfered square twisted bar, each with a pitch of twist not greater than 18 times the nominal size of the bar.

Type 2. A bar with transverse ribs with a substantially uniform spacing not greater than 0.8Φ (and continuous helical ribs where present), having a mean area of ribs (per unit length) above the core of the bar projected on a plane normal to the axis of the bar, of not less than $0.15\Phi \text{ mm}^2/\text{mm}$ where Φ is the size (nominal diameter) of the bar.

Other bars may be classified as types 1 or 2 from the results of the performance tests described in Part 7.

5.8.6.2 Local bond. To prevent local bond failure caused by large changes in tension over short lengths of reinforcement, the local bond stress, f_{bs} , obtained from equation 23 should not exceed the appropriate value obtained from Table 14.

$$f_{bs} = \frac{V \pm (M/d) \tan \theta_s}{\Sigma u_s d} \quad \text{equation 23}$$

which becomes

$$f_{bs} = \frac{V}{\Sigma u_s d}$$

when the bars are parallel to the compression face,

where

- V is the shear force due to ultimate loads;
- Σu_s is the sum of the effective perimeters of the tension reinforcement (see 5.8.6.4);
- d is the effective depth to tension reinforcement;
- M is the moment at the section due to ultimate loads;
- θ_s is the angle between the compression face of the section and the tension reinforcement.

In equation 23 the negative sign should be used when the moment is increasing numerically in the same direction as the effective depth of the section.

Critical sections for local bond occur at the ends of simply supported members, at points where tension bars stop and at points of contraflexure. However, points where tension bars stop and points of contraflexure need not be considered if the anchorage bond stresses in the continuing bars do not exceed 0.8 times the value in 5.8.6.3.

5.8.6.3 Anchorage bond. To prevent bond failure the tension or compression in any bar at any section due to ultimate loads should be developed on each side of the section by an appropriate embedment length or other end anchorage. The anchorage bond stress, assumed to be constant over the effective anchorage length, taken as the force in the bar divided by the product of the effective anchorage length and the effective perimeter of the bar or group of bars (see 5.8.6.4), should not exceed the appropriate value obtained from Table 15.

Table 14 — Ultimate local bond stresses

Bar type	Concrete grade			
	20	25	30	40 or more
	N/mm ²	N/mm ²	N/mm ²	N/mm ²
Plain bars	1.7	2.0	2.2	2.7
Deformed bars, type 1	2.1	2.5	2.8	3.4
Deformed bars, type 2	2.6	2.9	3.3	4.0

5.8.6.4 Effective perimeter of a bar or group of bars. The effective perimeter of a single bar may be taken as 3.14 times its nominal size. The effective perimeter of a group of bars (see 5.8.3.1) should be taken as the sum of the effective perimeters of the individual bars multiplied by the appropriate reduction factor given in Table 16.

5.8.6.5 Anchorage of links. A link may be considered to be fully anchored if it passes round another bar of at least its own size through an angle of 90° and continues beyond for a minimum length of eight times its own size, or through 180° and continues for a minimum length of four times its own size. In no case should the radius of any bend in the link be less than twice the radius of the test bend guaranteed by the manufacturer of the bar.

5.8.6.6 Laps and joints. Continuity of reinforcement may be achieved by a connection using any of the following jointing methods:

- a) lapping bars;
- b) butt welding (see 4.7);
- c) sleeving (see 7.3.2.2);
- d) threading of bars, parallel threads (see 7.3.2.3);
- e) threading of bars, tapered threads.

Such connections should occur, if possible, away from points of high stress and should be staggered appropriately.

The use of the jointing methods given in c) and d) and any other method not listed should be verified by test evidence.

In the tests the following criteria should be satisfied.

- a) When a test is made on a representative gauge length assembly comprising reinforcement of the size, grade and profile to be used and a coupler of the precise type to be used, the permanent elongation after loading to $0.6f_y$ should not exceed 0.1 mm.
- b) The design ultimate strength of the coupled bar should exceed the specified characteristic strength by the percentage specified in clause 10 of BS 4449:1988.

5.8.6.7 Lap lengths. When bars are lapped, the length of the lap should at least equal the anchorage length (derived from 5.8.6.3) required to develop the stress in the smaller of the two bars lapped. The length of the lap provided, however, should neither be less than 25 times the smaller bar size plus 150 mm in tension reinforcement nor be less than 20 times the smaller bar size plus 150 mm in compression reinforcement.

The lap length calculated in the preceding paragraph should be increased by a factor of 1.4 if any of the following conditions apply:

- a) the nominal cover to the lapped bars from the top of the section as intended to be cast is less than twice the bar size;
- b) the clear distance between the lap and another pair of lapped bars is less than 150 mm;
- c) a corner bar is being lapped and the nominal cover to either face is less than twice the bar size.

Where conditions a) and b) or conditions a) and c) apply the lap length should be increased by a factor of 2.0.

5.8.6.8 Hooks and bends. Hooks, bends and other reinforcement anchorages should be of such form, dimension and arrangement as to avoid overstressing the concrete. Hooks and bends should be in accordance with BS 4466.

The effective anchorage length of a hook or bend should be measured from the start of the bend to a point four times the bar size beyond the end of the bend, and may be taken as the lesser of 24 times the bar size or:

- a) for a hook, eight times the internal radius of the hook;
- b) for a 90° bend, four times the internal radius of the bend.

In no case should the radius of any bend be less than twice the radius of the test bend guaranteed by the manufacturer of the bar and, in addition, it should be sufficient to ensure that the bearing stress at the mid-point of the curve does not exceed the value given in 5.8.6.9.

When a hooked bar is used at a support, the beginning of the hook should be at least four times the bar size inside the face of the support.

5.8.6.9 Bearing stress inside bends. The bearing stress inside a bend, in a bar which does not extend or is not assumed to be stressed beyond a point four times the bar size past the end of the bend, need not be checked.

Table 15 — Ultimate anchorage bond stresses

Bar type	Concrete grade			
	20	25	30	40 or more
Plain bars in tension	N/mm ² 1.2	N/mm ² 1.4	N/mm ² 1.5	N/mm ² 1.9
Plain bars in compression	1.5	1.7	1.9	2.3
Deformed bars, type 1 in tension	1.7	1.9	2.2	2.6
Deformed bars, type 1 in compression	2.1	2.4	2.7	3.2
Deformed bars, type 2 in tension	2.2	2.5	2.8	3.3
Deformed bars, type 2 in compression	2.7	3.1	3.5	4.1

Table 16 — Reduction factor for effective perimeter of a group of bars

Number of bars in a group	Reduction factor
2	0.8
3	0.6
4	0.4

The bearing stress inside a bend in any other bar should be calculated from the equation:

$$\text{Bearing stress} = \frac{F_{bt}}{r\Phi}$$

where

F_{bt} is the tensile force due to ultimate loads in a bar or group of bars;

r is the internal radius of the bend;

Φ is the size of the bar or, in a bundle, the size of a bar of equivalent area.

The stress should not exceed $1.5f_{cu}/(1 + 2\Phi/\alpha_b)$ where α_b for a particular bar or group of bars in contact should be taken as the centre-to-centre distance between bars or groups of bars perpendicular to the plane of the bend; for a bar or group of bars adjacent to the face of the member, α_b should be taken as the cover plus Φ .

5.8.7 Curtailment and anchorage of reinforcement

In any member subject to bending every bar should extend, except at end supports, beyond the point at which it is no longer needed, for a distance equal to the effective depth of the member or 12 times the size of the bar, whichever is greater. A point at which reinforcement is no longer required is where the resistance moment of the section, considering only the continuing bars, is equal to the required moment.

In addition, reinforcement should not be stopped in a tension zone unless one of the following conditions is satisfied:

- the bars extend an anchorage length appropriate to their design strength ($0.87f_y$) from the point at which they are no longer required to resist bending; or
- the shear capacity at the section where the reinforcement stops is greater than twice the shear force actually present; or
- the continuing bars at the section where the reinforcement stops provide double the area required to resist the moment at that section.

One or other of these conditions should be satisfied for all arrangements of ultimate load considered.

At a simply supported end of a member each tension bar should be anchored by one of the following:

- an effective anchorage equivalent to 12 times the bar size beyond the centre line of the support; no bend or hook should begin before the centre of the support;
- an effective anchorage equivalent to 12 times the bar size plus $d/2$ from the face of the support, where d is the effective depth to tension reinforcement of the member; no bend should begin before $d/2$ from the face of the support.

5.8.8 Spacing of reinforcement

5.8.8.1 Minimum distance between bars. These recommendations are not related to bar sizes but when a bar exceeds the maximum size of coarse aggregate by more than 5 mm, a spacing smaller than the bar size should generally be avoided. A pair of bars in contact or a bundle of three or four bars in contact should be considered as a single bar of equivalent area when assessing size.

The spacing of bars should be suitable for the proper compaction of concrete and when an internal vibrator is likely to be used sufficient space should be left between reinforcement to enable the vibrator to be inserted.

Minimum reinforcement spacing is best determined by experience or proper works tests, but in the absence of better information the following may be used as a guide.

a) *Individual bars.* Except where bars form part of a pair or bundle [see b) and c)] the clear distance between bars should be not less than $h_{agg} + 5$ mm, where h_{agg} is the maximum size of the coarse aggregate. Where there are two or more rows:

- 1) the gaps between corresponding bars in each row should be in line;
- 2) the clear distance between rows should be not less than h_{agg} , except for precast members where it should be not less than $0.67h_{agg}$.

b) *Pairs of bars.* Bars may be arranged in pairs either touching or closer than in a), in which case:

- 1) the gaps between corresponding pairs in each row should be in line and of width not less than $h_{agg} + 5$ mm;
- 2) when the bars forming the pairs are one above the other, the clear distance between rows should be not less than h_{agg} , except for precast members where it should be not less than $0.67h_{agg}$;
- 3) when the bars forming the pair are side by side, the clear distance between rows should be not less than $h_{agg} + 5$ mm.

c) *Bundled bars.* Horizontal and vertical distances between bundles should be not less than $h_{agg} + 15$ mm and gaps between rows of bundles should be vertically in line.

5.8.8.2 Maximum distance between bars in tension.

The maximum spacing should be not greater than 300 mm and be such that the crack widths calculated using equations 24 and 26 as appropriate do not exceed the limits laid down in 4.1.1.1 under the design loadings given in 4.2.2.

a) For solid rectangular sections, stems of T beams and other solid sections shaped without re-entrant angles, the design crack widths at the surface (or, where the cover to the outermost bar is greater than c_{nom} , on a surface at a distance c_{nom} from the outermost bar) should be calculated from the following equation:

$$\text{Design crack width} = \frac{3a_{cr}\epsilon_m}{1 + 2(a_{cr} - c_{nom})/(h - d_c)} \quad \text{equation 24}$$

where

a_{cr} is the distance from the point (crack) considered to the surface of the nearest bar which controls the crack width;

c_{nom} is the required nominal cover to the outermost reinforcement given in Table 13; where the cover shown on the drawing is greater than the value given in Table 13, the latter value may be used;

d_c is the depth of the concrete in compression (if $d_c = 0$ the crack widths should be calculated using equation 26);

h is the overall depth of the section;

ϵ_m is the calculated strain at the level where cracking is being considered, allowing for the stiffening effect of the concrete in the tension zone; a negative value of ϵ_m indicates that the section is uncracked. The value of ϵ_m should be obtained from the equation:

$$\epsilon_m = \epsilon_1 - \left[\frac{3.8b_t h (a' - d_c)}{\epsilon_s A_s (h - d_c)} \right] \left[\left(1 - \frac{M_q}{M_g} \right) 10^{-9} \right] \quad \text{equation 25}$$

but not greater than ϵ_1

where

ϵ_1 is the calculated strain at the level where cracking is being considered, ignoring the stiffening effect of the concrete in the tension zone;

b_t is the width of the section at the level of the centroid of the tension steel;

a' is the distance from the compression face to the point at which the crack width is being calculated;

M_g is the moment at the section considered due to permanent loads;

M_q is the moment at the section considered due to live loads;

ϵ_s is the calculated strain in the tension reinforcement, ignoring the stiffening effect of the concrete in the tension zone;

A_s is the area of tension reinforcement.

Where the axis of the design moment and the direction of the tensile reinforcement resisting that moment are not normal to each other (e.g. in a skew slab), A_s should be taken as:

$$A_s = \Sigma (A_t \cos^4 \alpha_1)$$

where

A_t is the area of reinforcement in a particular direction;

α_1 is the angle between the axis of the design moment and the direction of the tensile reinforcement, A_t , resisting that moment.

b) For flanges in overall tension, including tensile zones of box beams and voided slabs, the design crack width at the surface (or at a distance c_{nom} from the outermost bar) should be calculated from the following equation:

$$\text{Design crack width} = 3a_{\text{cr}}\varepsilon_m \quad \text{equation 26}$$

where ε_m is obtained from equation 25.

c) Where global and local effects are calculated separately (see 4.8.3) the value of ε_m may be obtained by algebraic addition of the strains calculated separately. The design crack width should then be calculated in accordance with b) but may, in the case of a deck slab where a global compression is being combined with a local moment, be obtained using a), calculating d_c on the basis of the local moment only.

d) The spacing of transverse bars in slabs with circular voids should not exceed twice the minimum flange thickness.

5.8.9 Shrinkage and temperature reinforcement.

To prevent excessive cracking due to shrinkage and thermal movement, reinforcement should be provided in the direction of any restraint to such movements. In the absence of any more accurate determination, the area of reinforcement, A_s , parallel to the direction of each restraint, should be such that:

$$A_s \geq k_r (A_c - 0.5A_{\text{cor}})$$

where

k_r is 0.005 for grade 460 reinforcement and 0.006 for grade 250 reinforcement;

A_c is the area of the gross concrete section at right-angles to the direction of the restraint;

A_{cor} is the area of the core of the concrete section, A_c , i.e. that portion of the section more than 250 mm away from all concrete surfaces.

Shrinkage and temperature reinforcement should be distributed uniformly around the perimeter of the concrete section and spaced at not more than 150 mm.

Reinforcement that is present for other purposes may be taken into account for the purpose of this clause.

5.8.10 Arrangement of reinforcement in skew slabs

5.8.10.1 General. In all types of skew slab for which the moments and torsions have been determined by an elastic analysis, the reinforcement or prestressing tendons should be aligned as close as is practicable to the principal moment directions. In general, an orthogonal arrangement is recommended.

5.8.10.2 Solid slabs. Only for combinations of large skew angle and low ratio of skew breadth to skew span is it preferable to place reinforcement in directions perpendicular and parallel to the free edges. Usually it is more efficient to place reinforcement parallel and perpendicular to the supports, preferably in combination with bands of reinforcement positioned adjacent and parallel to the free edges.

Special attention should be given to the provision of adequate anchorage of bars meeting the free edge at an angle.

An alternative, but less efficient method, is to fan out the longitudinal steel from perpendicular to the supports to parallel to the free edge at the edge.

5.8.10.3 Voided slabs. The longitudinal steel will generally be placed parallel to the voids and it is recommended that the transverse steel be placed orthogonal to this steel.

5.8.10.4 Solid composite slabs. The longitudinal steel will generally be in the form of prestressing tendons in the precast units which are parallel to the free edges. Ideally, the transverse reinforcement should be placed at right-angles to the free edge, since this is the most efficient arrangement; however, in practice, the transverse reinforcement may frequently have to be placed at a different angle or parallel to the supports.

5.9 Additional considerations in the use of lightweight aggregate concrete

5.9.1 General. Lightweight aggregate concrete may generally be designed in accordance with the recommendations of clause 4 and of 5.1 to 5.8; 5.9.2 to 5.9.11 relate specifically to reinforced lightweight aggregate concrete of grade 25 or above. Only the recommendations of 7.5 (plain concrete walls) apply to concretes below grade 25.

In considering lightweight aggregate concrete, the properties for any particular type of aggregate can be established far more accurately than for most naturally occurring materials and the Engineer should therefore obtain specific data direct from the aggregate producer in preference to using tabulated values taken from codes of practice or British Standard specifications.

All the properties of lightweight aggregate concrete to be used in design should be supported by appropriate test data.

5.9.2 Durability. The minimum cement contents given in Part 8 apply to lightweight aggregate concrete.

For durability, the cover to reinforcement should be 10 mm greater than the values given in Table 13.

5.9.3 Characteristic strength. Values of characteristic strength of lightweight aggregate concretes may be taken from Table 5. When all aggregate in the concrete is sintered pulverized fuel ash, the related cube strength at other ages may be obtained from Table 5. These values apply to most other types of aggregate but reference should be made to the producer of the particular material under consideration. With some aggregates used in rich mixes, there may be little increase in strength beyond that attained at 28 days.

5.9.4 Shear resistance of beams. The shear resistance and shear reinforcement for lightweight aggregate concrete beams should be established in accordance with 5.3.3.1 and 5.3.3.2, except that Table 17 should be used in place of Table 8 and the maximum value of the shear stress, v , should be limited to the values given in Table 18.

Table 17 — Ultimate shear stress, v_c , in lightweight aggregate concrete beams without shear reinforcement

$\frac{100A_s}{bd}$	Concrete grade		
	25	30	40 or more
	N/mm ²	N/mm ²	N/mm ²
≤ 0.25	0.28	0.28	0.28
0.50	0.40	0.44	0.44
1.00	0.52	0.56	0.60
2.00	0.68	0.72	0.76
≥ 3.00	0.72	0.76	0.80

Table 18 — Maximum value of shear stress in lightweight aggregate concrete beams

Concrete grade		
25	30	40 or more
N/mm ²	N/mm ²	N/mm ²
3.00	3.28	3.80

5.9.5 Torsional resistance of slabs. The torsional resistance and reinforcement for lightweight aggregate concrete beams should be established in accordance with 5.3.4, except that Table 19 should be used in place of Table 10.

5.9.6 Deflection of beams. Deflection of lightweight aggregate concrete beams may be calculated using a value of E_c as described in 4.3.2.1.

Table 19 — Ultimate torsion shear stress in lightweight aggregate concrete beams

	Concrete grade		
	25	30	40 or more
	N/mm ²	N/mm ²	N/mm ²
v_{tmin}	0.26	0.30	0.34
v_{tu}	3.00	3.28	3.80

5.9.7 Shear resistance of slabs. The shear resistance and reinforcement or lightweight aggregate concrete slabs should be established in accordance with 5.4.4, except that Table 17 should be used in place of Table 8 and the maximum shear stress, v , should be limited to the values given in Table 18.

5.9.8 Deflection of slabs. Deflection of lightweight aggregate concrete slabs may be calculated using a value of E_c as described in 4.3.2.1.

5.9.9 Columns

5.9.9.1 General. The recommendations of 5.5 apply to lightweight aggregate concrete columns subject to the conditions in 5.9.9.2 and 5.9.9.3.

5.9.9.2 Short columns. In 5.5.1.1, the ratio of effective height, l_e , to thickness, h , for a short column should not exceed 10.

5.9.9.3 Slender columns. In 5.5.5, the divisor 1 750 in equations 18, 20, 21 and 22 should be replaced by the divisor 1 200.

5.9.10 Local bond, anchorage bond and laps.

Local bond stress, anchorage bond stress and lap lengths in reinforcement for lightweight aggregate concrete members should be established in accordance with 5.8.6, except that the bond stresses for plain and deformed bars should not exceed 50 % and 80 % respectively of those given in Table 14 and Table 15.

For foamed slag or similar aggregates it may be necessary to ensure that bond stresses are kept well below the maximum values in the preceding paragraph for reinforcement that is in a horizontal position during casting and values should be obtained from test data.

5.9.11 Bearing stress inside bends. The recommendations of 5.8.6.9 apply to lightweight aggregate concrete, except that the bearing stress should not exceed:

$$\frac{f_{cu}}{1 + \frac{2\Phi}{a_b}}$$

6 Design and detailing: prestressed concrete

6.1 General

6.1.1 Introduction. This clause gives methods of analysis and design which will in general ensure that, for prestressed concrete construction of classes 1, 2 and 3 as defined in 4.1.1.1, the recommendations set out in clause 4 are met. Other methods may be used provided they can be shown to be satisfactory for the type of structure or member considered. In certain cases the assumptions made in this clause may be inappropriate and the Engineer should adopt a more suitable method having regard to the nature of the structure in question.

Clause 6 does not cover prestressed concrete construction using any of the following in the permanent works:

- a) unbonded tendons;
- b) external tendons (a tendon is considered external if, after stressing and incorporating in the permanent works but before protection, it is outside the concrete section);
- c) lightweight aggregate.

6.1.2 Limit state design of prestressed concrete

6.1.2.1 Basis of design. Clause 6 follows the limit state philosophy set out in clauses 3 and 4 but, as it is not possible to assume that a particular limit state will always be the critical one, design methods are given for both the ultimate and the serviceability limit states.

In general, the design of class 1 and class 2 members is controlled by the cracking and concrete stress limitations for serviceability load conditions, but the ultimate strength in flexure, shear and torsion should be checked. The design of class 3 members is usually controlled by ultimate strength conditions, or by deflection.

6.1.2.2 Durability. Guidance is given in 6.8.2 on the minimum cover to reinforcement and prestressing tendons that should be provided to ensure durability.

6.1.2.3 Other limit states and considerations.

Clause 6 does not make recommendations concerning vibration or other limit states and for these and other considerations reference should be made to 4.1.1.2 and 4.1.3.

6.1.3 Loads. In clause 6, the design load effects (see 2.1) for the ultimate and serviceability limit states are referred to as “ultimate loads” and “service loads” respectively. The values of the “ultimate loads” and “service loads” to be used in design are derived from Part 2 and 4.2.

In clause 6, when analysing sections, the terms “strength”, “resistance” and “capacity” are used to describe the strength of the section.

Consideration should be given to the construction sequence and to the secondary effects due to prestress particularly for the serviceability limit states.

6.1.4 Strength of materials

6.1.4.1 Definition of strengths. In clause 6 the design strengths of materials are expressed in all the tables and equations in terms of the characteristic strength of the material. Unless specifically stated otherwise, all equations and tables include allowances for γ_m , the partial safety factor for material strength.

6.1.4.2 Characteristic strength of concrete. The characteristic cube strengths of concrete are given in Part 7 and those which may be specified for prestressed concrete are quoted in Table 20, together with their related cube strengths at other ages. The values given in Table 20 do not include any allowance for γ_m .

Design should be based on the characteristic strength, f_{cu} , except that at transfer the calculations should be based on the cube strength at transfer.

6.1.4.3 Characteristic strength of prestressing tendons. The specified characteristic strengths of prestressing tendons are given in:

- BS 4486 for high tensile alloy steel bars;
- BS 5896 for high tensile steel wire and strand including drawn or compacted strand complying with section 3.

The values given in these British Standards do not include any allowance for γ_m .

6.2 Structures and structural frames

6.2.1 Analysis of structures. Complete structures and complete structural frames may be analysed in accordance with the recommendations of 4.4 but when appropriate the methods given in 6.3 may be used for the design of individual members.

The relative stiffness of members should generally be based on the concrete section as described in 4.4.2.1.

6.2.2 Redistribution of moments. Redistribution of moments obtained by rigorous elastic analysis under the ultimate limit state may be carried out provided the following conditions are met.

- a) Appropriate checks are made to ensure that adequate rotation capacity exists at sections where moments are reduced, making reference to appropriate test data.

In the absence of a special investigation, the plastic rotation capacity may be taken as the lesser of:

$$1) 0.008 + 0.035 \left(0.5 - \frac{d_c}{d_e} \right)$$

or

$$2) \frac{10}{d - d_c}$$

but not less than 0 or more than 0.015

where

- d_c is the calculated depth of concrete in compression at the ultimate limit state (in mm);
- d_e is the effective depth for a solid slab or rectangular beam, otherwise the overall depth of the compression flange (in mm);
- d is the effective depth to tension reinforcement (in mm).

- b) Proper account is taken of changes in transverse moments, transverse deflections and transverse shears consequent on redistribution of longitudinal moments by means of an appropriate non-linear analysis.
- c) Shears and reactions used in design are taken as either those calculated prior to redistribution or after redistribution, whichever is greater.
- d) The depth of the members or elements considered is less than 1 200 mm.

6.3 Beams

6.3.1 General

6.3.1.1 Definitions. The definitions and limitations of the geometric properties for prestressed beams are as given for reinforced concrete beams in 5.3.1.

6.3.1.2 Slender beams. In addition to limiting the slenderness of a beam (see 5.3.1.3) when under load in its final position, the possible instability of a prestressed beam during erection should be considered.

Members may collapse by tilting about a longitudinal axis through the lifting points. This initial tilting, which may be due to imperfections in beam geometry and in locating the lifting points, could cause lateral bending moments and these, if too high, could result in lateral instability.

The problem is complex and previous experience should be relied on in considering a particular case. The following factors may require consideration:

- beam geometry, i.e. type of cross section span/breadth/depth ratios, etc.;
- location of lifting points;
- methods of lifting, i.e. inclined or vertical slings, type of connection between the beam and the slings;
- tolerances in construction, e.g. maximum lateral bow.

The stresses due to the combined effects of lateral bending, dead load and prestress can be assessed and, if cracking is possible, the lifting arrangements should be changed or the beam should be provided with adequate lateral support.

6.3.2 Serviceability limit state: flexure

6.3.2.1 Section analysis. The following assumptions may be made when considering design loads.

- Plane sections remain plane.
- For class 1 and class 2 members elastic behaviour exists for the concrete up to stresses given in 6.3.2.2 and 6.3.2.4. For class 3 members elastic behaviour is deemed to exist up to the compressive and hypothetical tensile stresses given in 6.3.2.2 and 6.3.2.4. The elastic modulus may be taken as that given in 4.3.2.1.
- In general, it may only be necessary to calculate stresses due to the load combinations given in Part 2 immediately after the transfer of prestress and after all losses of prestress have occurred; in both cases the effects of dead and imposed loads on the strain and force in the tendons may be ignored.

Table 20 — Strength of concrete

Grade	Characteristic strength, f_{cu}	Cube strength at an age of				
		7 days	2 months ^a	3 months ^a	6 months ^a	1 year ^a
	N/mm ²	N/mm ²	N/mm ²	N/mm ²	N/mm ²	N/mm ²
30	30.0	20	33	35	36	37
40	40.0	28	44	45.5	47.5	50
50	50.0	36	54	55.5	57.5	60
60	60.0	45	64	65.5	67.5	70

^a Increased strengths at these ages should be used only if the Engineer is satisfied that the materials used are capable of producing these higher strengths.

6.3.2.2 Concrete compressive stress limitations

a) *Under service loads.* The compressive stresses in the concrete under the loads given in 4.2 should not exceed the values given in Table 22. Higher stresses are permissible for prestressed members used in composite construction (see 7.4.3.2).

Table 22 — Compressive stresses in concrete for serviceability limit states

Nature of loading	Allowable compressive stresses
Design load in bending	$0.4f_{cu}$
Design load in direct compression	$0.3f_{cu}$

b) *At transfer.* The compressive stresses in the concrete at transfer should not exceed the values given in Table 23, where f_{ci} is the concrete strength at transfer.

Table 23 — Allowable compressive stresses at transfer

Nature of stress distribution	Allowable compressive stresses
Triangular or near triangular distribution of stress	$0.5f_{ci}$ but $\leq 0.4f_{cu}$
Uniform or near uniform distribution of stress	$0.4f_{ci}$ but $\leq 0.3f_{cu}$

6.3.2.3 Steel stress limitations. The stress in the prestressing tendons under the loads given in 4.2 need not be checked. The stress at transfer should be checked in accordance with 6.7.1.

6.3.2.4 Cracking

a) *Under service loads.* The recommendations of 4.1.1.1 are deemed to be satisfied provided that the flexural tensile stresses under the loading given in 4.2.2 do not exceed the following values given in 1), 2) or 3) or the appropriate class (but see 7.3.3 for joints in post-tensioned segmental construction).

1) *Class 1 members.* No tensile stress, except as indicated in 6.3.2.4 b) 1).

2) *Class 2 members.* The tensile stresses should not exceed the design flexural tensile strength of the concrete, which is $0.45\sqrt{f_{cu}}$ for pre-tensioned members and $0.36\sqrt{f_{cu}}$ for post-tensioned members. The limiting tensile stresses are given in Table 24.

3) *Class 3 members.* For class 3 members in which cracking is allowed (see 4.1.1.1) it may be assumed that the concrete section is uncracked and that hypothetical tensile stresses exist at the maximum size of cracks defined in 4.1.1.1. The hypothetical tensile stresses for use in these calculations for members with either pre-tensioned or post-tensioned tendons are given in Table 25, modified by the coefficients in Table 26 and the following paragraph.

The cracking in prestressed concrete flexural members is dependent on the member depth, and the stress given by Table 25 should be modified by multiplying by the appropriate factor from Table 26.

For composite construction when flexural stresses given in Table 25 are not exceeded during construction, the full depth of the composite section should be used when using Table 26.

When additional reinforcement is contained within the tension zone and positioned close to the tension faces of the concrete, these hypothetical tensile stresses may be increased by an amount that is proportional to the cross-sectional areas of the additional reinforcement expressed as a percentage of the cross-sectional area of the tensile concrete. For 1 % of additional reinforcement the stresses in Table 25 may be increased by 4.0 N/mm^2 for members in groups a) and b) and by 3.0 N/mm^2 for members in group c). For other percentages of additional reinforcement the stresses may be increased in proportion, except that the total hypothetical tensile stress should not exceed one-quarter of the characteristic cube strength of the concrete.

Where the hypothetical tensile stresses in Table 25 are to be increased to allow for additional reinforcement, and where the depth factors in Table 26 also apply, the values to be used should be obtained by first multiplying the basic stress from Table 25 by the appropriate factor from Table 26 and then adding the allowance for additional reinforcement.

b) *At transfer and during construction.* The flexural tensile stress in the concrete should not exceed the following values (but see 7.3.3 for joints in post-tensioned segmental construction):

- 1) 1 N/mm^2 due solely to prestress and co-existent dead and temporary loads during erection (see Part 2);
- 2) $0.45 \sqrt{f_{ci}}$ for pre-tensioned members and $0.36 \sqrt{f_{ci}}$ for post-tensioned members due to all other load combinations. Members with pre-tensioned tendons should have some tendons or additional reinforcement well distributed throughout the tensile zone of the section and members with post-tensioned tendons should, if necessary, have additional reinforcement located near the tension face of the member.

Table 24 — Flexural tensile stresses for class 2 members: serviceability limit state: cracking

	Allowable stress for concrete grade			
	30	40	50	60
	N/mm ²	N/mm ²	N/mm ²	N/mm ²
Pre-tensioned members	—	2.9	3.2	3.5
Post-tensioned members	2.1	2.3	2.55	2.8

Table 25 — Hypothetical flexural tensile stresses for class 3 members

	Limiting crack width	Stress for concrete grade		
		30	40	50 and over
	mm	N/mm ²	N/mm ²	N/mm ²
a) Pre-tensioned tendons	0.1	—	4.1	4.8
	0.15	—	4.5	5.3
	0.25	—	5.5	6.3
b) Grouted post-tensioned tendons	0.1	—	4.1	4.8
	0.15	3.5	4.5	5.3
	0.25	4.1	5.5	6.3
c) Pre-tensioned tendons distributed in the tensile zone and positioned close to the tension faces of the concrete	0.1	—	5.3	6.3
	0.15	—	5.8	6.8
	0.25	—	6.8	7.8

Table 26 — Depth factor for tensile stresses for class 3 members

Depth of member	Depth factor
mm	
200 and under	1.1
400	1.0
600	0.9
800	0.8
1 000 and over	0.7

6.3.3 Ultimate limit state: flexure

6.3.3.1 Section analysis. When analysing a cross section to determine its ultimate strength the following assumptions should be made.

- The strain distribution in the concrete in compression is derived from the assumption that plane sections remain plane.
- The stresses in the concrete in compression are derived either from the stress-strain curve given in Figure 1, with $\gamma_m = 1.5$, or, in the case of rectangular sections or flanged sections with the neutral axis in the flange, the compressive stress may be taken as equal to $0.4f_{cu}$ over the whole compression zone; in both cases the strain at the outermost compression fibre is taken as 0.0035.
- The tensile strength of the concrete is ignored.
- The strains in bonded prestressing tendons and in any additional reinforcement, whether in tension or compression, are derived from the assumption that plane sections remain plane. In addition, the tendon will have an initial strain due to prestress after all losses.

e) The stresses in bonded prestressing tendons, whether initially tensioned or untensioned, and in additional reinforcement, are derived from the appropriate stress-strain curves, with $\gamma_m = 1.15$; the stress-strain curves for prestressing tendons are given in Figure 3 and Figure 4 and those for reinforcement in Figure 2. An empirical approach for obtaining the stress in the tendons at failure is given in 6.3.3.3 and Table 27.

In addition, if the ultimate moment of resistance calculated as in a) to e) is less than 1.15 times the required value, the section should be proportioned such that the strain in the outermost tendon is not less than:

$$0.005 + \frac{f_{pu}}{E_s \gamma_m}$$

where E_s is the modulus of elasticity of the steel.

Where the outermost tendon, or layer of tendons, provides less than 25 % of the total tendon area, this condition should also be met at the centroid of the outermost 25 % of tendon area.

As an alternative, the strains in the concrete and the bonded prestressing tendons and any additional reinforcement, due to the application of ultimate loads, may be calculated using the following assumptions.

- The strain distribution in the concrete in compression and the strains in bonded prestressing tendons and any additional reinforcement, whether in tension or compression, are derived from the assumption that plane sections remain plane. In addition, the tendons will have an initial strain due to prestress after all losses.
- The stresses in the concrete in compression are derived from the stress-strain curve given in Figure 1, with $\gamma_m = 1.5$.

- h) The tensile strength of the concrete is ignored.
- i) The stresses in bonded prestressing tendons, whether initially tensioned or untensioned, and in additional reinforcement, are derived from the appropriate stress-strain curves, with $\gamma_m = 1.15$; the stress-strain curves for prestressing tendons are given in Figure 3 and Figure 4 and those for reinforcement in Figure 2.

In using the alternative method of analysis, the calculated strain due to the application of ultimate loads at the outermost compression fibre of the concrete should not exceed 0.0035. In addition, the section should be proportioned such that the strain at the centroid of the outermost 25 % of the cross-sectional area of the tendons is not less than $0.005 + f_{pu}/(E_s\gamma_m)$ except where the requirement for the calculated strain in the concrete, due to the application of 1.15 times the ultimate loads, can be satisfied.

6.3.3.2 Design charts. The design charts in BS 8110-3 include charts, based on Figure 1, Figure 3 and Figure 4, and the assumptions given in 6.3.3.1, which may be used for the design of rectangular prestressed beams.

6.3.3.3 Design formula. In the absence of an analysis based on the assumptions given in 6.3.3.1, the resistance moment of a rectangular beam, or of a flanged beam in which the neutral axis lies within the flange, may be obtained from equation 27.

$$M_u = f_{pb}A_{ps}(d - 0.5x) \quad \text{equation 27}$$

where

- M_u is the ultimate moment of resistance of the section;
- f_{pb} is the tensile stress in the tendons at failure;
- x is the neutral axis depth;
- d is the effective depth to tension reinforcement;
- A_{ps} is the area of the prestressing tendons in the tension zone.

Values for f_{pb} and x may be derived from Table 27 for pre-tensioned members and for post-tensioned members with effective bond between the concrete and tendons, provided that the effective prestress after all losses is not less than $0.45f_{pu}$. Prestressing tendons and additional reinforcement in the compression zone are ignored in strength calculations when using this method.

6.3.3.4 Non-rectangular sections. Non-rectangular beams should be analysed using the assumptions given in 6.3.3.1.

6.3.4 Shear resistance of beams

6.3.4.1 General. Calculations for shear are only required for the ultimate limit state. It may be necessary to carry out calculations at construction stages (see 6.3.4.6). The provisions of this clause apply to class 1, class 2 and class 3 prestressed concrete members.

At any section the ultimate shear resistance of the concrete alone, V_c , should be considered for the section both uncracked (see 6.3.4.2) and cracked (see 6.3.4.3) in flexure, and if necessary shear reinforcement should be provided (see 6.3.4.4).

For a cracked section the conditions of maximum shear with co-existent bending moment and maximum bending moment with co-existent shear should both be considered.

Within the transmission length of pre-tensioned members (see 6.7.4), the shear resistance of a section should be taken as the greater of the values calculated from:

- 5.3.3 except that in determining the area A_s , the area of tendons should be ignored; and
- 6.3.4.2 to 6.3.4.4, using the appropriate value of prestress at the section considered, assuming a linear variation of prestress over the transmission length.

6.3.4.2 Sections uncracked in flexure. It may be assumed that the ultimate shear resistance of a section uncracked in flexure, V_{co} , corresponds to the occurrence of a maximum principal tensile stress, at the centroidal axis of the section, of $f_t = 0.24\sqrt{f_{cu}}$.

In the calculation of V_{co} , the value of f_{cp} should be derived from the prestressing force after all losses have occurred, multiplied by the appropriate value of γ_{fl} (see 4.2.3). The value of V_{co} is given by:

$$V_{co} = 0.67bh\sqrt{(f_t^2 + f_{cp}f_t)} \quad \text{equation 28}$$

where

- f_t is $0.24\sqrt{f_{cu}}$, taken as positive;
- f_{cp} is the compressive stress at the centroidal axis due to prestress, taken as positive;
- ^a b is the breadth of the member which for T, I and L beams should be replaced by the breadth of the rib, b_w ;
- h is the overall depth of the member.

^a Where the position of a duct coincides with the position of maximum principal tensile stress, e.g. at or near the junction of flange and web near a support, the value of b should be reduced by the full diameter of the duct if ungrouted and by two-thirds of the diameter if grouted.

Table 27 — Conditions at the ultimate limit state for rectangular beams with pre-tensioned tendons, or with post-tensioned tendons having effective bond

$\frac{f_{pu}A_{ps}}{f_{cu}bd}$	Stress in tendons as a proportion of the design strength, $f_{pb}/0.87f_{pu}$		Ratio of depth of neutral axis to that of the centroid of the tendons in the tension zone, x/d	
	Pre-tensioning	Post-tensioning with effective bond	Pre-tensioning	Post-tensioning with effective bond
0.025	1.0	1.0	0.054	0.054
0.05	1.0	1.0	0.109	0.109
0.10	1.0	1.0	0.217	0.217
0.15	1.0	1.0	0.326	0.326
0.20	1.0	0.95	0.435	0.414 ^a
0.25	1.0	0.90	0.542	0.480 ^a
0.30	1.0	0.85	0.655	0.558 ^a
0.40	0.9	0.75	0.783 ^a	0.653 ^a

^a The neutral axis depth in these cases is too low to provide the elongation given in 6.3.3.1. It is essential therefore that the strength provided should exceed that strictly required by 15 %.

In flanged members where the centroidal axis occurs in the flange, the principal tensile stress should be limited to $0.24\sqrt{f_{cu}}$ at the intersection of the flange and web; in this calculation, the algebraic sum of the stress due to the bending moment under ultimate loads and the stress due to prestress at this intersection should be used in calculating V_{co} .

For a section with inclined tendons, the component of prestressing force (multiplied by the appropriate value of γ_{fl}) normal to the longitudinal axis of the member should be algebraically added to V_{co} . This component should be taken as positive where the shear resistance of the section is increased.

6.3.4.3 Sections cracked in flexure

a) *Class 1 and class 2.* The ultimate shear resistance of a section cracked in flexure, V_{cr} , may be calculated using equation 29.

$$V_{cr} = 0.037bd\sqrt{f_{cu}} + \frac{M_{cr}}{M} V \quad \text{equation 29}$$

where

d is the distance from the extreme compression fibre to the centroid of the tendons at the section considered;

M_{cr} is the cracking moment at the section considered:

$$M_{cr} = (0.37\sqrt{f_{cu}} + f_{pt})I/\gamma$$

in which f_{pt} is the stress due to prestress only at the tensile fibre distance y from the centroid of the concrete section which has a second moment of area I ; the value of f_{pt} should be derived from the prestressing force after all losses have occurred, multiplied by the appropriate value of γ_{fl} (see 4.2.3);

V and M are the shear force and bending moment (both taken as positive) at the section considered due to ultimate loads;

V_{cr} should be taken as not less than $0.1bd\sqrt{f_{cu}}$.

b) *Class 3*. The ultimate shear resistance of a section cracked in flexure, V_{cr} , may be calculated using equation 30.

$$V_{cr} = \left(1 - 0.55 \frac{f_{pe}}{f_{pu}} \right) v_c b d + M_o \frac{V}{M} \quad \text{equation 30}$$

where

V and M are as defined previously;

M_o is the moment necessary to produce zero stress in the concrete at the depth d :

$$M_o = f_{pt} I / y$$

in which f_{pt} is the stress due to prestress only at the depth d , distance y from the centroid of the concrete section which has a second moment of area I ; the value of f_{pt} should be derived from the prestressing force after all losses have occurred, multiplied by the appropriate value of γ_{fL} (see 4.2.3);

f_{pe} is the effective prestress after all losses have occurred, multiplied by the appropriate value of γ_{fL} (see 4.2.3); for the purposes of this equation f_{pe} should be not greater than $0.6f_{pu}$;

v_c is obtained from Table 8;

A_s (required in using Table 8) should be taken as the actual area of steel in the tension zone, irrespective of its characteristic strength;

d is the distance from the compression face to the centroid of the steel area, A_s .

For cases where both tensioned and untensioned steel are contained in A_s , f_{pe}/f_{pu} may be taken as:

$$\frac{P_f}{A_{s(t)} f_{pu(t)} + A_{s(u)} f_{yL(u)}}$$

where

P_f is the effective prestressing force after all losses;

$A_{s(t)}$ is the area of tensioned steel;

$A_{s(u)}$ is the area of untensioned steel;

$f_{pu(t)}$ is the characteristic strength of the tensioned steel;

$f_{yL(u)}$ is the characteristic strength of the untensioned steel;

V_{cr} should be taken as not less than $0.1 b d \sqrt{f_{cu}}$.

The value of V_{cr} calculated using equations 29 and 30 at a particular section may be assumed to be constant for a distance equal to $d/2$, measured in the direction of increasing moment, from that particular section.

For a section cracked in flexure and with inclined tendons, the component of prestressing force normal to the longitudinal axis of the member should be ignored.

6.3.4.4 Shear reinforcement. Minimum shear reinforcement should be provided in the form of links such that:

$$\frac{A_{sv}}{s_v} \left(\frac{0.87 f_{yv}}{b} \right) = 0.4 \text{ N/mm}^2$$

where

f_{yv} is the characteristic strength of the link reinforcement but not greater than 460 N/mm^2 ;

A_{sv} is the total cross-sectional area of the leg of the links;

s_v is the link spacing along the length of the beam.

When the shear force, V , due to the ultimate loads exceeds V_c , the shear reinforcement provided should be such that:

$$\frac{A_{sv}}{s_v} = \frac{V + 0.4 b d_t - V_c}{0.87 f_{yv} d_t}$$

Where links are used, the area of longitudinal steel in the tensile zone should be such that:

$$A_s \geq \frac{V}{2(0.87 f_y)}$$

where

A_s is the area of effectively anchored longitudinal tensile reinforcement (see 5.8.7) and prestressing tendons (excluding debonded tendons) additional to that required at the ultimate limit state for other purposes;

f_y is the characteristic strength of the longitudinal reinforcement and prestressing tendons but not greater than 460 N/mm^2 .

In rectangular beams, at both corners in the tensile zone, a link should pass round a longitudinal bar, a tendon, or a group of tendons having a diameter not less than the link diameter. In this clause on shear reinforcement, the effective depth, d_t , should be taken as the depth from the extreme compression fibre either to these longitudinal bars or to the centroid of the tendons, whichever is greater. A link should extend as close to the tension and compression faces as possible, with due regard to cover. The links provided at a cross section should between them enclose all the tendons and additional reinforcement provided at the cross section and should be adequately anchored (see 5.8.6.5).

The spacing of links along a beam should not exceed $0.75d_t$, nor four times the web thickness for flanged beams. When V exceeds $1.8 V_c$, the maximum spacing should be reduced to $0.5d_t$. The lateral spacing of the individual legs of the links provided at a cross section should not exceed $0.75d_t$.

6.3.4.5 Maximum shear force. In no circumstances should the shear force, V , due to ultimate loads, exceed the appropriate value given by Table 28 multiplied by bd , where b is as defined in 6.3.4.2, less either the diameter of the duct for temporarily ungrouted ducts or two-thirds the diameter of the duct for grouted ducts; d is the distance from the compression face to the centroid of the area of steel in the tension zone, irrespective of its characteristic strength.

Table 28 — Maximum shear stress

	Concrete grade			
	30	40	50	60 and over
Maximum shear stress	N/mm ² 4.1	N/mm ² 4.7	N/mm ² 5.3	N/mm ² 5.8

6.3.4.6 Segmental construction. Shear resistance verification for post-tensioned segmental structures is generally performed in the same way as for non-segmental structures, except that special consideration is required at joints, particularly during the erection phase.

In addition to the check on the completed structure, calculations for shear at joints should also be carried out for each discrete stage of erection.

In the case of wide joints with cast-in-situ concrete, dry-pack mortar or grout joint filler, the shear force due to ultimate loads at each erection stage and on completion of the structure should not be greater than

$$0.7 (\tan \alpha_2) \cdot \gamma_{fL} \cdot P_h$$

where

γ_{fL} is the partial safety factor for the prestressing force, to be taken as 0.87;

P_h is the horizontal component of the force after losses appropriate to the construction stage under consideration or, in the case of the completed structure, after all losses.

α_2 is the angle of friction at the joint. $\tan \alpha_2$ depends on the type of interface; for roughened and moistened segment faces a value of 0.7 may be adopted for erection phases, and 1.4 at completion.

In the case of match cast joints, the maximum shear forces should be calculated as for wide joints and suitable shear keys should be used. The design and detailing of shear keys should be agreed with the relevant bridge authority.

6.3.5 Torsional resistance of beams

6.3.5.1 General. Torsion does not usually decide the dimensions of members; therefore torsional design should be carried out as a check after the flexural design. This is particularly relevant to some members in which the maximum torsional moment does not occur under the same loading as the maximum flexural moment. In such circumstances reinforcement and prestress in excess of that required for flexure and shear may be used in torsion.

The provisions of this clause apply to class 1, class 2 and class 3 prestressed concrete members.

6.3.5.2 Stresses and reinforcement. Calculations for torsion are only required for the ultimate limit state and the torsional shear stresses should be calculated assuming a plastic shear stress distribution.

Calculations for torsion should be in accordance with 5.3.4 with the following modifications. When prestressing steel is used as transverse torsional steel, in accordance with equations 10 and 10(a), or as longitudinal steel, in accordance with equation 11, the stress assumed in design should be the lesser of $(f_{pe} + 460/\gamma_m)$ or $0.87f_{pu}$.

The compressive stress in the concrete due to prestress should be taken into account separately in accordance with 5.3.4.5.

In calculating $(v + v_t)$, for comparison with v_{tu} in Table 10, v should be calculated from equation 8, regardless of whether 6.3.4.2 or 6.3.4.3 is critical in shear.

For concrete grades above 40 the values of v_{tu} given in Table 10 may be increased to $0.75\sqrt{f_{cu}}$ but not more than 5.8 N/mm^2 .

6.3.5.3 Segmental construction. When a structure to be constructed segmentally is designed for torsion, and additional torsional steel is necessary in accordance with equation 11, the distribution of this longitudinal steel, whether by reinforcement or prestressing tendons, should comply with the recommendations of 5.3.4.5. Other arrangements may be used provided that the line of action of the longitudinal elongating force is at the centroid of the steel.

6.3.5.4 Other design methods. Alternative methods of designing members subjected to combined bending, shear and torsion may be used provided that it can be shown that they satisfy both the ultimate and serviceability limit state requirements.

6.3.6 Longitudinal shear. For flanged beams the longitudinal shear resistance across vertical sections of the flange which may be critical, should be checked in accordance with 7.4.2.3.

6.3.7 Deflection of beams

6.3.7.1 Class 1 and class 2 members. The instantaneous deflection due to design loads may be calculated using elastic analysis based on the concrete section properties and on the value for the modulus of elasticity given in 4.3.2.1.

The total long term deflection due to the prestressing force, dead load and any sustained imposed loading may be calculated using elastic analysis based on the concrete section properties and on an effective modulus of elasticity based on the creep of the concrete per unit length for unit applied stress after the period considered (specific creep). The values for specific creep given in 6.7.2.5 may in general be used unless a more accurate assessment is required (see Appendix C). Due allowance should be made for the loss of prestress after the period considered.

6.3.7.2 Class 3 members. Where the permanent load is less than or equal to 25 % of the design imposed load, the deflection of class 3 members may be calculated in accordance with 6.3.7.1. Where the permanent load is greater than 25 % of the design load, calculations based on the moment curvature relationship should be made.

6.4 Slabs. The analysis of prestressed slabs should be in accordance with 5.4.1 provided that due allowance is made for moments due to prestress. The design should be in accordance with 6.3.

The design for shear should be in accordance with 6.3.4 except that shear reinforcement need not be provided if V is less than V_c .

In the treatment of shear stresses under concentrated loads, the ultimate shear resistance of a section uncracked in flexure, V_{co} , may be taken as corresponding to the occurrence of a maximum principal tensile stress of $f_t = 0.24 \sqrt{f_{cu}}$ at the centroidal axis around the critical section which is assumed as a perimeter $h/2$ from the loaded area. The values of V_{co} given in Table 28 may be used with b being taken as the length of the critical perimeter. Reinforcement, if necessary, should be provided in accordance with 6.3.4.4.

6.5 Columns. Prestressed concrete columns, where the mean stress in the concrete section imposed by the tendons is less than 2.5 N/mm^2 , may be analysed as reinforced columns in accordance with 5.5, otherwise the full effects of the prestress should be considered.

6.6 Tension members. The tensile strength of tension members should be based on the design strength ($0.87f_{pu}$) of the prestressing tendons and the strength developed by any additional reinforcement. The additional reinforcement may usually be assumed to be acting at its design stress ($0.87f_y$); in special cases it may be necessary to check the stress in the reinforcement using strain compatibility.

Members subject to axial tension should also be checked at the serviceability limit state to comply with the appropriate stress limitations of 6.3.2.4.

6.7 Prestressing requirements

6.7.1 Maximum initial prestress. Immediately after anchoring, the force in the prestressing tendon should not exceed 70 % of the characteristic strength for post-tensioned tendons, or 75 % for pre-tensioned tendons. The jacking force may be increased to 80 % during stressing, provided that additional consideration is given to safety, to the stress-strain characteristics of the tendon, and to the assessment of the friction losses.

In determining the jacking force to be used, consideration should also be given to the gripping or anchorage efficiency of the anchorage determined in accordance with BS 4447.

Where deflected tendons are used in prestressing systems, consideration should be given, in determining the maximum initial prestress, to the possible influence of the size of the deflector on the strength of the tendons. Attention should also be paid to the effect of any frictional forces that may occur.

6.7.2 Loss of prestress, other than friction losses

6.7.2.1 General. Allowance should be made when calculating the forces in tendons at the various stages in design for the appropriate losses of prestress resulting from:

- a) relaxation of the steel comprising the tendons;
- b) the elastic deformation and subsequent shrinkage and creep of the concrete;
- c) slip or movement of tendons at anchorages during anchoring;
- d) other causes in special circumstances, e.g. when steam curing is used with pre-tensioning.

If experimental evidence on performance is not available, account should be taken of the properties of the steel and of the concrete when calculating the losses of prestress from these causes. For a wide range of structures, the simple recommendations given in this clause should be used; it should be recognized, however, that these recommendations are necessarily general and approximate.

6.7.2.2 Loss of prestress due to relaxation of steel.

The loss of force in the tendon allowed for in the design should be the maximum relaxation after 1 000 h duration, for a jacking force equal to that imposed at transfer, as given by the appropriate British Standard.

No reduction in the value of the relaxation loss should be made for a tendon when a load equal to or greater than the relevant jacking force has been applied for a short time prior to the anchoring of the tendon.

In special cases, such as tendons at high temperatures or subjected to large lateral loads (e.g. deflected tendons), greater relaxation losses will occur. Specialist literature should be consulted in these cases.

6.7.2.3 Loss of prestress due to elastic deformation of the concrete. Calculation of the immediate loss of force in the tendons due to elastic deformation of the concrete at transfer may be based on the values for the modulus of elasticity of the concrete given in Table 3. The modulus of elasticity of the tendons may be obtained from 4.3.2.2.

For pre-tensioning, the loss of prestress in the tendons at transfer should be calculated on a modular ratio basis using the stress in the adjacent concrete.

For members with post-tensioning tendons that are not stressed simultaneously, there is a progressive loss of prestress during transfer due to the gradual application of the prestressing force. The resulting loss of prestress in the tendons should be calculated on the basis of half the product of the modular ratio and the stress in the concrete adjacent to the tendons, averaged along their length; alternatively, the loss of prestress may be computed exactly based on the sequence of tensioning.

In making these calculations, it may usually be assumed that the tendons are located at their centroid.

6.7.2.4 Loss of prestress due to shrinkage of the concrete. The loss of prestress in the tendons due to shrinkage of the concrete may be calculated from the modulus of elasticity for the tendons given in 4.3.2.2, assuming the values for shrinkage per unit length given in Table 29.

Table 29 — Shrinkage of concrete

System	Shrinkage per unit length	
	Humid exposure (90 % r.h.)	Normal exposure (70 % r.h.)
Pre-tensioning: transfer at between 3 days and 5 days after concreting	100×10^{-6}	300×10^{-6}
Post tensioning: transfer at between 7 days and 14 days after concreting	70×10^{-6}	200×10^{-6}

For other ages of concrete at transfer, for other conditions of exposure, or for massive structures, some adjustment to these figures will be necessary, in which case reference should be made to Appendix C or specialist literature.

When it is necessary to determine the loss of prestress and the deformation of the concrete at some stage before the total shrinkage is reached, it may be assumed for normal aggregate concrete that half the total shrinkage takes place during the first month after transfer and that three-quarters of the total shrinkage takes place in the first 6 months after transfer.

6.7.2.5 Loss of prestress due to creep of the concrete. The loss of prestress in the tendons due to creep of the concrete should be calculated on the assumption that creep is proportional to stress in the concrete for stress of up to one-third of the cube strength at transfer. The loss of prestress is obtained from the product of the modulus of elasticity of the tendon (see 4.3.2.2) and the creep of the concrete adjacent to the tendons. Usually it is sufficient to assume, in calculating this loss, that the tendons are located at their centroid.

For pre-tensioning at between 3 days and 5 days after concreting and for humid or dry conditions of exposure where the required cube strength at transfer is greater than 40.0 N/mm^2 , the creep of the concrete per unit length should be taken as 48×10^{-6} per N/mm^2 . For lower values of cube strength at transfer the creep per unit length should be taken as $48 \times 10^{-6} \times 40.0/f_{ci}$ per N/mm^2 .

For post-tensioning at between 7 days and 14 days after concreting and for humid or dry conditions of exposure where the required cube strength at transfer is greater than 40.0 N/mm^2 , the creep of the concrete per unit length should be taken as 36×10^{-6} per N/mm^2 . For lower values of cube strength at transfer the creep per unit length should be taken as $36 \times 10^{-6} \times 40.0/f_{ci}$ per N/mm^2 .

Where the maximum stress anywhere in the section at transfer exceeds one-third of the cube strength of the concrete the value for the creep per unit length used in calculations should be increased. When the maximum stress at transfer is half the cube strength, the values for creep are 1.25 times the values given in the preceding paragraphs; at intermediate stresses, the values should be interpolated linearly.

The figures for creep of the concrete per unit length relate to the ultimate creep after a period of years. When it is necessary to determine the deformation of the concrete due to creep at some earlier stage, it may be assumed that half the total creep takes place in the first month after transfer and that three-quarters of the total creep takes place in the first 6 months after transfer.

In applying the preceding recommendations, which are necessarily general, reference should be made to Appendix C or specialist literature for more detailed information on the factors affecting creep.

6.7.2.6 Loss of prestress during anchorage. In post-tensioning systems allowance should be made for any movement of the tendon at the anchorage when the prestressing force is transferred from the tensioning equipment to the anchorage. The loss due to this movement is particularly important in short members, and for such members the allowance made by the designer should be checked on the site.

6.7.2.7 Losses of prestress due to steam curing.

Where steam curing is employed in the manufacture of prestressed concrete units, changes in the behaviour of the material at higher than normal temperatures will need to be considered.

In addition, where the "long line" method of pre-tensioning is used there may be additional losses as a result of bond developed between the tendon and the concrete when the tendon is hot and relaxed. Since the actual losses of prestress due to steam curing are a function of the techniques used by the various manufacturers, specialist advice should be sought.

6.7.3 Loss of prestress due to friction

6.7.3.1 General. In post-tensioning systems there will be movement of the greater part of the tendon relative to the surrounding duct during the tensioning operation, and if the tendon is in contact with either the duct or any spacers provided, friction will cause a reduction in the prestressing force as the distance from the jack increases. In addition, a certain amount of friction will be developed in the jack itself and in the anchorage through which the tendon passes.

In the absence of evidence established to the satisfaction of the Engineer, the stress variation likely to be expected along the design profile should be assessed in accordance with **6.7.3.2** to **6.7.3.5** in order to obtain the prestressing force at the critical sections considered in design. The extension of the tendon should be calculated allowing for the variation in tension along its length.

6.7.3.2 Friction in the jack and anchorage. This is directly proportional to the jack pressure, but it will vary considerably between systems and should be ascertained for the type of jack and the anchorage system to be used.

6.7.3.3 Friction in the duct due to unintentional variation from the specified profile. Whether the desired duct profile is straight or curved or a combination of both, there will be slight variations in the actual line of the duct, which may cause additional points of contact between the tendon and the sides of the duct, and so produce friction. The prestressing force, P_x , at any distance x from the jack may be calculated from:

$$P_x = P_0 e^{-Kx} \quad \text{equation 31}$$

and where $Kx \leq 0.2$, e^{-Kx} may be taken as $1 - Kx$

where

- P_0 is the prestressing force in the tendon at the jacking end;
 e is the base of Napierian logarithms (2.718);
 K is the constant depending on the type of duct, or sheath employed, the nature of its inside surface, the method of forming it and the degree of vibration employed in placing the concrete.

The value of K per metre length in equation 31 should generally be taken as not less than 33×10^{-4} , but where strong rigid sheaths or duct formers are used closely supported so that they are not displaced during the concreting operation, the value of K may be taken as 17×10^{-4} . Other values may be used provided they have been established by tests to the satisfaction of the Engineer.

6.7.3.4 Friction in the duct due to curvature of the tendon. When a tendon is curved, the loss of tension due to friction is dependent on the angle turned through and the coefficient of friction, μ , between the tendon and its supports.

The prestressing force, P_x , at any distance x along the curve from the tangent point may be calculated from:

$$P_x = P_0 e^{-\mu x/r_{ps}} \quad \text{equation 32}$$

where

- P_0 is the prestressing force in the tendons at the tangent point near the jacking end;
 r_{ps} is the radius of curvature.

Where $\mu x/r_{ps} \leq 0.2$, $e^{-\mu x/r_{ps}}$ may be taken as $1 - \mu x/r_{ps}$.

Where $(Kx + \mu x/r_{ps}) \leq 0.2$, $e^{-(Kx + \mu x/r_{ps})}$ may be taken as $1 - (Kx + \mu x/r_{ps})$.

Values of μ may be taken as:

- 0.55 for steel moving on concrete;
 0.30 for steel moving on steel;
 0.25 for steel moving on lead.

The value of μ may be reduced where special precautions are taken and where results are available to justify the value assumed. For example, a value of $\mu = 0.10$ has been observed for strand moving on rigid steel spacers coated with molybdenum disulphide. Such reduced values should be agreed with the relevant bridge authority.

6.7.3.5 Friction in circular construction. Where circumferential tendons are tensioned by means of jacks the losses due to friction may be calculated from the formula in 6.7.3.4, but the values of μ may be taken as:

- 0.45 for steel moving in smooth concrete;
 0.25 for steel moving on steel bearers fixed to the concrete;
 0.10 for steel moving on steel rollers.

6.7.3.6 Lubricants. Lubricants may be specified to ease the movement of tendons in the ducts. Lower values of μ than those given in 6.7.3.4 and 6.7.3.5 may then be used, subject to their being determined by trial and agreed with the relevant bridge authority. The requirements of Part 7 should then be satisfied.

6.7.4 Transmission length in pre-tensioned members. The transmission length is defined as the length over which a tendon is bonded to concrete to transmit the initial prestressing force in a tendon to the concrete.

The transmission length depends on a number of variables, the most important being:

- the degree of compaction of the concrete;
- the strength of the concrete;
- the size and type of tendon;
- the deformation (e.g. crimp) of the tendon;
- the stress in the tendon; and
- the surface condition of the tendon.

The transmission lengths for the tendon towards the top of a unit may be greater than those at the bottom. The sudden release of tendons may also cause a considerable increase in the transmission lengths.

Where the initial prestressing force is not greater than 75 % of the characteristic strength of the tendon and where the concrete strength at transfer is not less than 30 N/mm^2 , the transmission length, l_t , may be taken as follows:

$$l_t = \frac{k_t \Phi}{\sqrt{f_{ci}}}$$

where

- f_{ci} is the concrete strength at transfer (in N/mm^2);
- l_t is the transmission length (in mm);
- Φ is the nominal diameter of the tendon (in mm);
- k_t is a coefficient dependent on the type of tendon, to be taken as:
- 600 for plain, indented and crimped wire with a total wave height less than 0.15Φ ;
 - 400 for crimped wire with a total wave height greater than or equal to 0.15Φ ;
 - 240 for 7-wire standard and super strand;
 - 360 for 7-wire drawn or compacted strand.

The development of stress from the end of the unit to the point of maximum stress should be assumed to be linear over the transmission length.

If the tendons are prevented from bonding to the concrete near the ends of the units by the use of sleeves or tape, the transmission lengths should be taken from the ends of the de-bonded portions.

6.7.5 End blocks. The end block (also known as the anchor block or end zone) is defined as the highly stressed zone of concrete around the termination points of a pre- or post-tensioned prestressing tendon. It extends from the point of application of prestress (i.e. the end of the bonded part of the tendon in pre-tensioned construction or the anchorage in post-tensioned construction) to that section of the member at which linear distribution of stress is assumed to occur over the whole cross section.

The following aspects of design should be considered in assessing the strength of end blocks:

- a) bursting forces around individual anchorages;
- b) overall equilibrium of the end block;
- c) spalling of the concrete from the loaded face around anchorages.

In considering each of these aspects, particular attention should be given to factors such as the following:

- 1) shape, dimensions and position of anchor plates relative to the cross section of the end block;
- 2) the magnitude of the prestressing forces and the sequence of prestressing;
- 3) shape of the end block relative to the general shape of the member;

- 4) layout of anchorages including asymmetry, group effects and edge distances;
- 5) influence of the support reaction;
- 6) forces due to curved or divergent tendons.

The following recommendations are appropriate to a circular, square or rectangular anchor plate, symmetrically positioned on the end face of a square or rectangular post-tensioned member; the recommendations are followed by some guidance on other aspects.

The bursting tensile forces in the end blocks, or end regions of bonded post-tensioned members, should be assessed on the basis of the tendon jacking load. For temporarily unbonded members, the bursting tensile forces should be assessed on the basis of the tendon jacking load or the load in the tendon at the ultimate limit state, calculated using **6.1.4.3**, whichever is the greater.

The bursting tensile force, F_{bst} , existing in an individual square end block loaded by a symmetrically placed square anchorage or bearing plate, may be derived from Table 30,

where:

- y_o is half the side of end block;
- y_{po} is half the side of loaded area;
- P_k is the load in the tendon assessed in accordance with the preceding paragraph;
- F_{bst} is the bursting tensile force.

Table 30 — Design bursting tensile forces in end blocks

y_{po}/y_o	0.3	0.4	0.5	0.6	0.7
F_{bst}/P_k	0.23	0.20	0.17	0.14	0.11

This force, F_{bst} , will be distributed in a region extending from $0.2y_o$ to $2y_o$ from the loaded face of the end block. Reinforcement provided to sustain the bursting tensile force may be assumed to be acting at its design strength ($0.87f_y$), except that the stress should be limited to a value corresponding to a strain of 0.001 when the concrete cover to the reinforcement is less than 50 mm.

In the rectangular end blocks, the bursting tensile forces in the two principal directions should be assessed on the basis of the formulae in Table 30.

When circular anchorage or bearing plates are used, the side of the equivalent square area should be derived.

Where groups of anchorages or bearing plates occur, the end blocks should be divided into a series of symmetrically loaded prisms and each prism treated in the preceding manner. In detailing the reinforcement for the end block as a whole it is necessary to ensure that the groups of anchorages are appropriately tied together.

Special attention should be paid to end blocks having a cross section different in shape from that of the general cross section of the beam; reference should be made to the specialist literature.

Compliance with the preceding recommendations will generally ensure that bursting tensile forces along the load axis are provided for. Alternative methods of design which use higher values of F_{bst}/P_k and allow for the tensile strength of concrete may be more appropriate in some cases, particularly where large concentrated tendon forces are involved.

Consideration should also be given to the spalling tensile stresses that occur in end blocks where the anchorage or bearing plates are highly eccentric; these reach a maximum at the loaded face.

6.8 Considerations affecting design details

6.8.1 General. The considerations in 6.8.2 to 6.8.6 are intended to supplement those for reinforced concrete given in 5.8.

6.8.2 Cover to prestressing tendons

6.8.2.1 General. The cover to prestressing tendons will generally be governed by considerations of durability.

6.8.2.2 Pre-tensioned tendons. The recommendations of 5.8.2 concerning cover to reinforcement may be taken to be applicable. The ends of individual pre-tensioned tendons do not normally require concrete cover and should preferably be cut off flush with the end of the concrete member.

6.8.2.3 Tendons in ducts. The cover to any duct should be not less than 50 mm. Precautions should be taken to ensure a dense concrete cover, particularly with large or wide ducts.

Recommendations for the cover to curved tendons in ducts are given in Appendix D.

6.8.3 Spacing of prestressing tendons

6.8.3.1 General. In all prestressed members there should be sufficient gaps between the tendons or bars to allow the largest size of aggregate used to move, under vibration, to all parts of the mould.

6.8.3.2 Pre-tensioned tendons. The recommendations of 5.8.8.1 concerning spacing of reinforcement may be taken to be applicable. In pre-tensioned members, where anchorage is achieved by bond, the spacing of the wires or strands in the ends of the members should be such as to allow the transmission lengths given in 6.7.4 to be developed. In addition, if the tendons are positioned in two or more widely spaced groups, the possibility of longitudinal splitting of the member should be considered.

6.8.3.3 Tendons in ducts. The clear distance between ducts or between ducts and other tendons should be not less than the following, whichever is the greatest:

- $h_{agg} + 5$ mm, where h_{agg} is the maximum size of the coarse aggregate;
- in the vertical direction: the vertical internal dimension of the duct;
- in the horizontal direction: the horizontal internal dimension of the duct; where internal vibrators are used sufficient space should be provided between ducts to enable the vibrator to be inserted.

Where two or more rows of ducts are used the horizontal gaps between the ducts should be vertically in line wherever possible, for ease of construction.

Recommendations for the spacing of curved tendons in ducts are given in Appendix D.

6.8.4 Longitudinal reinforcement in prestressed concrete beams. Reinforcement may be used in prestressed concrete members either to increase the strength of sections or to comply with the recommendations of 6.3.4.4.

Any stress or strength calculation taking account of additional reinforcement should still be in accordance with 6.3.2.2 and 6.3.3.1.

Reinforcement may be necessary, particularly where post-tensioning systems are used, to control any cracking resulting from restraint to longitudinal shrinkage of members provided by the formwork during the time before the prestress is applied.

6.8.5 Links in prestressed concrete beams. The amount and disposition of links in rectangular beams and in the webs of flanged beams will normally be governed by considerations of shear (see 6.3.4).

Links to resist the bursting tensile forces in the end zones of post-tensioned members should be provided in accordance with 6.7.5.

Links should be provided in the transmission length of pre-tensioned members in accordance with 6.3.4 and using the information given in 6.7.4.

6.8.6 Shock loading. When a prestressed concrete beam may be required to resist shock loading, it should be reinforced with closed links and longitudinal reinforcement, preferably of grade 250 steel. Other methods of design and detailing may be used, provided it can be shown that the beam can develop the required ductility.

6.8.7 Deflected tendons

6.8.7.1 Pre-tensioned tendons. For single tendons the deflector in contact with the tendon should produce a radius of not less than 5 times the tendon diameter for wire or 10 times the diameter for strand and the total angle of deflection should not exceed 15°.

6.8.7.2 Post-tensioned tendons. The deflector in contact with the tendon should have a radius of not less than 50 times the diameter of the tendon and the total angle of deflection should not exceed 15°.

7 Design and detailing: precast, composite and plain concrete construction

7.1 General

7.1.1 Introduction. This clause is concerned with the additional considerations that arise in design and detailing when precast members or precast components including large panels are incorporated into a structure or when a structure in its entirety is of precast concrete construction. It also covers the use of plain concrete for walls and abutments.

7.1.2 Limit state design

7.1.2.1 Basis of design. The limit state philosophy set out in clause 4 applies equally to precast and in situ construction and therefore, in general, the recommended methods of design and detailing for reinforced concrete given in clause 5 and those for prestressed concrete given in clause 6 apply also to precast and composite construction. Subclauses in clause 5 or 6 which do not apply are either specifically worded for in situ construction or are modified by this clause.

7.1.2.2 Handling stresses. Precast units should be designed to resist without permanent damage all stresses induced by handling, storage, transport and erection (see also 6.3.1.2). When necessary the positions of lifting and supporting points should be specified. Consultation at the design stage with those responsible for handling is an advantage. The design should take account of the effect of snatch lifting and placing on to supports.

7.1.2.3 Connections and joints. The design of connections is of fundamental importance in precast construction and should be carefully considered.

Joints to allow for movements due to shrinkage, thermal effects and possible differential settlement of foundations are of as great importance in precast as in in situ construction. The number and spacing of such joints should be determined at an early stage in the design. In the design of beam and slab ends on corbels and nibs, particular care should be taken to provide overlap and anchorage, in accordance with 5.8.7, of all reinforcement adjacent to the contact faces, full regard being paid to construction tolerances.

7.2 Precast concrete construction

7.2.1 Framed structures and continuous beams. When the continuity of reinforcement or tendons through the connections and/or the interaction between members is such that the structure will behave as a frame, or other rigidly interconnected system, the analysis, re-distribution of moments and the design and detailing of individual members, may all be in accordance with clause 5 or 6, as appropriate.

7.2.2 Other precast members. All other precast concrete members including large panels should be designed and detailed in accordance with the appropriate recommendations of clauses 5, 6 or 7.5 and should incorporate provision for the appropriate connections as recommended in 7.3.

Precast components intended for use in composite construction (see 7.4) should be designed as such but also checked or designed for the conditions arising during handling, transporting and erecting.

7.2.3 Supports for precast members

7.2.3.1 Concrete corbels. A corbel is a short cantilever beam in which the principal load is applied such that the distance a_v between the line of action of the load and the face of the supporting member is less than $0.6d$ and the depth at the outer edge of the bearing is not less than one-half of the depth at the face of the supporting member.

The depth at the face of the supporting member should be determined from shear conditions in accordance with 5.3.3.3, but using the modified definition of a_v given in the preceding paragraph.

The main tension reinforcement in a corbel should be designed and the strength of the corbel checked, on the assumption that it behaves as a simple strut and tie system. The reinforcement so obtained should be not less than 0.4 % of the section at the face of the supporting member and should be adequately anchored. At the front face of the corbel, the reinforcement should be anchored by bending back the bars to form a loop; the bearing area of the load should not project beyond the straight portion of the bars forming the main tension reinforcement.

When the corbel is designed to resist a stated horizontal force, additional reinforcement should be provided to transmit this force in its entirety; the reinforcement should be adequately anchored within the supporting member.

Shear reinforcement should be provided in the form of horizontal links distributed in the upper two-thirds of the effective depth of the corbel at the column face; this reinforcement need not be calculated but should be not less than one-half of the area of the main tension reinforcement and should be adequately anchored.

The corbel should also be checked at the serviceability limit states.

7.2.3.2 Width of supports for precast units. The width of supports for precast units should be sufficient to ensure proper anchorage of tension reinforcement in accordance with 5.8.7.

7.2.3.3 Bearing stresses. The compressive stress in the contact area should not exceed $0.4f_{cu}$ under the ultimate loads. When the members are made of concretes of different strengths, the lower concrete strength is applicable.

Higher bearing stresses may be used where suitable measures are taken to prevent splitting or spalling of the concrete, such as the provision of well-defined bearing areas and additional binding reinforcement in the ends of the members. Bearing stresses due to ultimate loads should then be limited to:

$$\frac{1.5f_{cu}}{1 + 2 \sqrt{\frac{A_{con}}{A_{sup}}}} \quad \text{but not more than } f_{cu}$$

where

A_{con} is the contact area;

A_{sup} is the supporting area.

where

$$A_{sup} = (b_x + 2x)(b_y + 2y) \text{ and}$$

$$x \leq b_x, y \leq b_y$$

where

b_x and b_y are the dimension of the bearing in the x and y directions respectively (see Figure 6a);

x and y are the dimensions from the boundary of the contact area to the boundary of the support area;

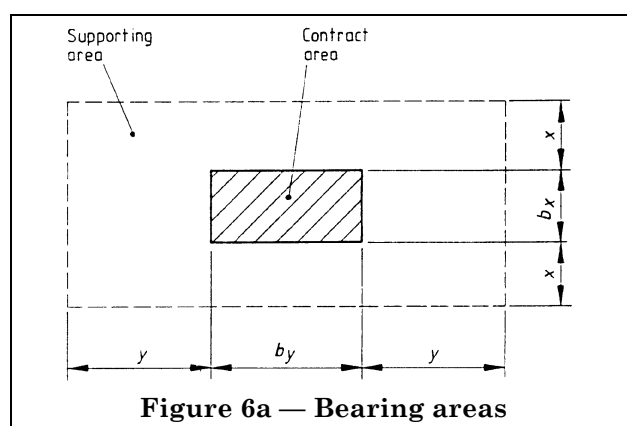

Figure 6a — Bearing areas

For lightweight aggregate concrete the bearing stresses due to ultimate loads should be limited to:

$$\frac{f_{cu}}{1 + 2 \sqrt{\frac{A_{con}}{A_{sup}}}} \quad \text{but not more than } 0.67 f_{cu}$$

Higher bearing stresses due to ultimate loads should be used only where justified by tests, e.g. concrete hinges.

7.2.3.4 Horizontal forces or rotations at bearings. The presence of significant horizontal forces at a bearing can reduce the load-carrying capacity of the supporting and supported member considerably by causing premature splitting or shearing. These forces may be due to creep, shrinkage and temperature effects or result from misalignment, lack of plumb or other causes. When they are likely to be significant these forces should be allowed for in designing and detailing the connection by providing either:

- sliding bearings (see Part 9); or
- suitable lateral reinforcement in the top of the supporting member; and
- continuity reinforcement to tie together the ends of the supported members.

Where, owing to large spans or other reasons, large rotations are likely to occur at the end supports of flexural members, suitable bearings capable of accommodating these rotations should be used.

7.2.4 Joints between precast members

7.2.4.1 General. The critical sections of members close to joints should be designed to resist the worst combinations of shear, axial force and bending caused by the ultimate vertical and horizontal forces. When the design of the precast members is based on the assumption that the joint between them is not capable of transmitting bending moment, the design of the joint should either ensure that this is so (see 7.3.2.4) or suitable precautions should be taken to ensure that if any cracking develops it will not excessively reduce the member's resistance to shear or axial force and will not be unsightly.

Where a space is left between two or more precast units, to be filled later with in situ concrete or mortar, the space should be large enough for the filling material to be placed easily and compacted sufficiently to fill the gap completely, without abnormally high standards of workmanship or supervision. The erection instructions should contain definite information as to the stage during construction when the gap should be filled.

The majority of joints will incorporate a structural connection (see 7.3) and consideration to this aspect should be given in the design of the joint.

7.2.4.2 Halving joint. It is difficult to provide access to this type of joint to reset or replace the bearings. Halving joints should only be used where it is absolutely essential.

For the type of joint shown in Figure 7, the maximum vertical ultimate load, F_v , should not exceed $4v_c b d_o$, where b is the breadth of the beam, d_o is the depth to additional reinforcement to resist horizontal loading and v_c is the shear stress given by Table 8 for the full beam section. When determining the value of F_v consideration should be given to the method of erection and the forces involved.

The joint should be reinforced by inclined links so that the vertical component of force in the link is equal to F_v , i.e.:

$$F_v = A_{sv}(0.87f_{yv}) \cos 45^\circ \text{ for links at } 45^\circ,$$

where

A_{sv} is the cross sectional area of the legs of the inclined links;

f_{yv} is the characteristic strength of the inclined links.

The links and any longitudinal reinforcement taken into account should intersect the line of action of F_v .

In the compression face of the beam the links should be anchored in accordance with 5.8.6.5. In the tension face of the beam the horizontal component, F_h , which for 45° links is equal to F_v , should be transferred to the main reinforcement. If the main reinforcement is continued straight on without hooks or bends the links may be considered anchored if:

$$\frac{F_h}{2 \sum u_s / s_b} < \text{the anchorage bond stress as given in Table 15}$$

where

$\sum u_s$ is the sum of the effective perimeters of the reinforcement;

l_{sb} is the length of the straight reinforcement beyond the intersection with the link.

If the main reinforcement is hooked or bent vertically, the inclined links should be anchored by bending them parallel to the main reinforcement; in this case, or if inclined links are replaced by bent-up bars, the bearing stress inside the bends should not exceed the value given in 5.8.6.8.

If there is a possibility of a horizontal load being applied to the joint, horizontal links should be provided to carry the load (as shown in Figure 7); such links should also be provided if there is possibility of the inclined links being displaced so that they do not intersect the line of action of F_v .

The joint may alternatively be reinforced with vertical links, designed in accordance with 5.3.3, provided the links are adequately anchored.

The joint should also be checked at the serviceability limit states.

7.3 Structural connections between units

7.3.1 General

7.3.1.1 Structural requirements of connections.

When designing and detailing the connections across joints between precast members the overall stability of the structure, including its stability during construction, should be considered.

7.3.1.2 Design method. Connections should, where possible, be designed in accordance with the generally accepted methods applicable to reinforced concrete (see clause 5), prestressed concrete (see clause 6) or structural steel. Where, by the nature of the construction or material used, such methods are not applicable, the efficiency of the connection should be proved by appropriate tests in accordance with Part 1.

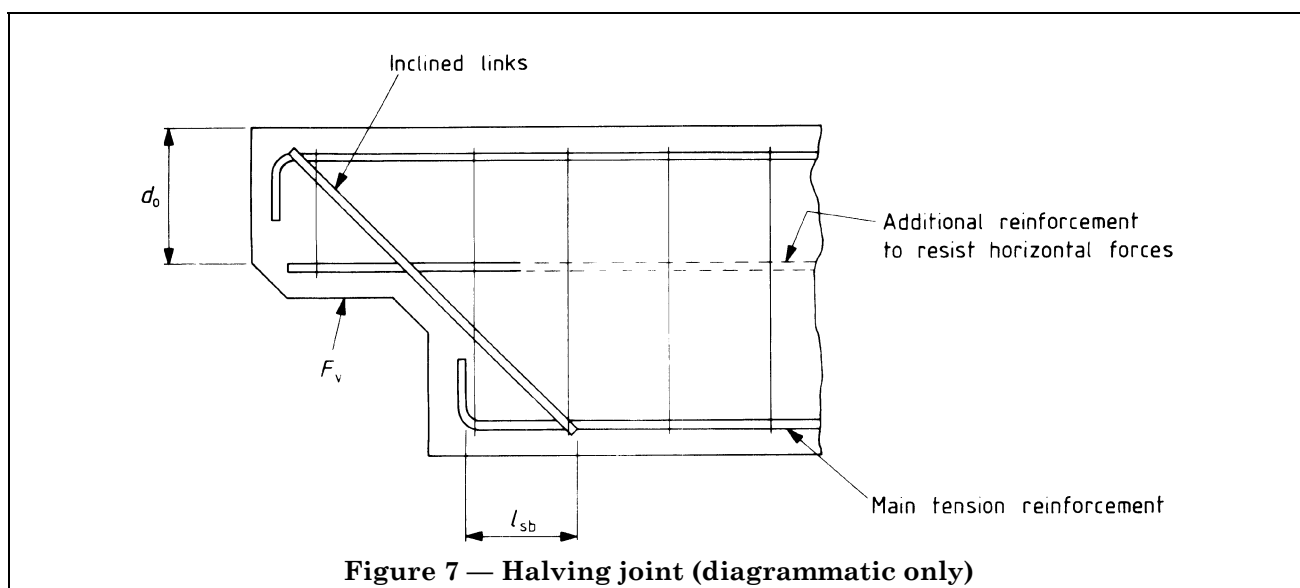

Figure 7 — Halving joint (diagrammatic only)

7.3.1.3 Considerations affecting design details. In addition to ultimate strength requirements the following should be considered.

- a) *Protection.* Connections should be designed to maintain the standard of protection against weather and corrosion required for the remainder of the structure.
- b) *Appearance.* Where connections are to be exposed, they should be so designed that the quality of appearance required for the remainder of the structure can be readily achieved.
- c) *Manufacture, assembly and erection.* Methods of manufacture and erection should be considered during design, and the following points should be given particular attention.
 - 1) Where projecting bars or sections are required, they should be kept to a minimum and made as simple as possible. The lengths of such projections should be not more than necessary for security.
 - 2) Fragile fins and nibs should be avoided.
 - 3) Fixing devices should be located in concrete sections of adequate strength.
 - 4) The practicability of both casting and assembly should be considered.
 - 5) Most connections require the introduction of suitable jointing material. Sufficient space should be allowed in the design for such material to ensure that the proper filling of the joint is practicable.

7.3.1.4 Factors affecting design and construction.

The strength and stiffness of any connection can be significantly affected by workmanship on site. The following points should be considered where appropriate:

- a) sequence of forming the joint;
- b) critical dimensions allowing for tolerances, e.g. minimum permissible bearing;
- c) critical details, e.g. accurate location required for a particular reinforcing bar;
- d) method of correcting possible lack of fit in the joint;
- e) details of temporary propping and time when it may be removed;
- f) description of general stability of the structure with details of any necessary temporary bracing;
- g) how far the uncompleted structure may proceed in relation to the completed and matured section;
- h) full details of special materials should be given;
- i) weld sizes should be fully specified; where weld symbols as given in BS 499 are used it should be ascertained that these are understood on site.

7.3.2 Continuity of reinforcement

7.3.2.1 General. Where continuity of reinforcement is required through the connection, the jointing method used should be such that the assumptions made in analysing the structure and critical sections are realized. The following methods may be used to achieve continuity of reinforcement:

- a) lapping bars;
- b) butt welding;
- c) sleeving;
- d) threading of bars.

The use of the jointing methods given in c) and d) and any other method not listed should be verified by test evidence.

7.3.2.2 Sleeving. Three principal types of sleeve jointing may be used, provided that the strength and deformation characteristics, including behaviour under fatigue conditions, have been determined by tests in accordance with Part 1:

- a) grout or resin filled sleeves capable of transmitting both tensile and compressive forces;
- b) sleeves that mechanically align the square-sawn ends of two bars to allow the transmission of compressive forces only;
- c) sleeves that are mechanically swaged to the bars and are capable of transmitting both tensile and compressive forces.

The detailed design of the sleeve and the method of manufacture and assembly should be such as to ensure that the ends of the two bars can be accurately aligned into the sleeve. The concrete cover provided for the sleeve should be not less than that specified for normal reinforcement.

7.3.2.3 Threading. The following methods may be used for joining threaded bars.

- a) The threaded ends of bars may be joined by a coupler having left- and right-hand threads. This type of threaded connection requires a high degree of accuracy in manufacture in view of the difficulty of ensuring alignment.
- b) One set of bars may be welded to a steel plate that is drilled to receive the threaded ends of the second set of bars; the second set of bars are fixed to the plate by means of nuts.
- c) Threaded anchors may be cast into a precast unit to receive the threaded ends of reinforcement.

Where there is a risk of the threaded connection working loose, e.g. during vibration of in situ concrete, a locking device should be used.

Where there is difficulty in producing a clean thread at the end of a bar, steel normally specified for black bolts (see BS 4190) having a characteristic strength of 430 N/mm^2 should be used.

The structural design of special threaded connections should be based on tests in accordance with Part 1, including behaviour under fatigue conditions where relevant. Where tests have shown the strength of the threaded connection to be at least as strong as the parent bar, the strength of the joint may be based on 80 % of the specified characteristic strength of the joined bars in tension and on 100 % for bars in compression, divided in each case by the appropriate γ_m factor.

7.3.2.4 Welding of bars. The design of welded connections should be in accordance with 5.8.6.6.

7.3.3 Other types of connection. Any other type of connection which can be capable of carrying the ultimate loads acting on it may be used subject to verification by test evidence. Amongst those suitable for resisting shear and flexure are those made by prestressing across the joint.

Resin adhesives, where tests have shown their acceptability, may be used to form joints subjected to compression but not to resist tension or shear.

For resin mortar joints, the flexural stresses in the joint should be compressive throughout under service loads. During the jointing operation at the construction stage, the average compressive stress between the concrete surfaces to be joined should be checked at the serviceability limit state and should lie between 0.2 N/mm^2 and 0.3 N/mm^2 measured over the total projection of the joint surface (locally not less than 0.15 N/mm^2) and the difference between flexural stresses across the section should be not more than 0.5 N/mm^2 .

For cement mortar joints, the flexural stresses in the joint should be compressive throughout and not less than 1.5 N/mm^2 under service loads.

7.4 Composite concrete construction

7.4.1 General. The recommendations of 7.4 apply to flexural members consisting of precast concrete units acting in conjunction with added concrete where provision has been made for the transfer of horizontal shear at the contact surface. The precast units may be of either reinforced or prestressed concrete.

In general, the analysis and design of composite concrete structures and members should be in accordance with clause 5 or 6, modified where appropriate by 7.4.2 and 7.4.3. Particular attention should be given in the design of both the component parts and the composite section to the effect, on stresses and deflections, of the method of construction and whether or not props are used. A check for adequacy should be made for each stage of construction. The relative stiffnesses of members should be based on the concrete, gross transformed or net transformed section properties as described in 4.4.2.1; if the concrete strengths in the two components of the composite member differ by more than 10 N/mm^2 , allowance for this should be made in assessing stiffnesses and stresses.

Differential shrinkage of the added concrete and precast concrete members requires consideration in analysing composite members for the serviceability limit states (see 7.4.3.4); it need not be considered for the ultimate limit state.

When precast prestressed units, having pre-tensioned tendons, are designed as continuous members and continuity is obtained with reinforced concrete cast in situ over the supports, the compressive stresses due to prestress in the ends of the units may be assumed to vary linearly over the transmission length for the tendons in assessing the strength of sections.

7.4.2 Ultimate limit state

7.4.2.1 General. Where the cross section of composite members and the applied loading increase by stages (e.g. a precast prestressed unit initially supporting self-weight and the weight of added concrete and subsequently acting compositely for live loading), the entire load may be assumed to act on the cross section appropriate to the stage being considered.

7.4.2.2 Vertical shear. The assessment of the resistance of composite sections to vertical shear and the provision of shear reinforcement should be in accordance with 5.3.3 for reinforced concrete (except that in determining the area A_s , the area of tendons within the transmission length should be ignored) and 6.3.4 for prestressed concrete, modified where appropriate as follows.

a) For I, M, T, U and box beam precast prestressed concrete units with an in situ reinforced concrete top slab cast over the precast units (including pseudo box construction), the shear resistance should be based on either of the following:

- 1) the vertical shear force, V , due to ultimate loads may be assumed to be resisted by the precast unit acting alone and the shear resistance assessed in accordance with 6.3.4;

- 2) the vertical shear force, V , due to ultimate loads may be assumed to be resisted by the composite section and the shear resistance assessed in accordance with 6.3.4. In this case, section properties should be based on those of the composite section, with due allowance for the different grades of concrete where appropriate.

b) For inverted T beam precast prestressed concrete units with transverse reinforcement placed through standard holes in the bottom of the webs of the units, completely in filled with concrete placed between and over the units to form a solid deck slab, the shear resistance and provision of shear reinforcement should be based on either of the following:

- 1) as in a) 1);
- 2) the vertical shear force, V , due to ultimate loads, may be apportioned between the infill concrete and the precast prestressed units on the basis of cross-sectional area with due allowance for the different grades of concrete where appropriate. The shear resistance for the infill concrete section and the precast prestressed section should be assessed separately in accordance with 5.3.3 and 6.3.4 respectively.

In applying 5.3.3, the breadth of the infill concrete should be taken as the distance between adjacent precast webs and the depth as the mean depth of infill concrete, or the mean effective depth to the longitudinal reinforcement where this is provided in the infill section.

In applying 6.3.4, the breadth of the precast section should be taken as the web thickness and the depth as the depth of the precast unit.

c) In applying 6.3.4.4, d_t should be derived for the composite section.

7.4.2.3 Longitudinal shear. The longitudinal shear force, V_1 , per unit length of a composite member, whether simply supported or continuous, should be calculated at the interface of the precast unit and the in situ concrete and at any vertical planes which may be critical in longitudinal shear, e.g. planes 2-2 or 2'-2' in Figure 8, by an elastic method using properties of the composite concrete section (see 4.4.2.1) with due allowance for different grades of concrete where appropriate.

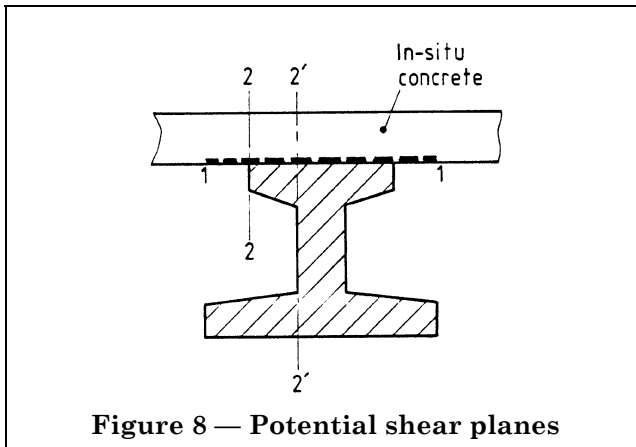

Figure 8 — Potential shear planes

V_1 should not exceed the lesser of the following:

- a) $k_1 f_{cu} L_s$
- b) $v_1 L_s + 0.7 A_e f_y$

where

k_1 is a constant depending on the concrete bond across the shear plane under consideration, taken from Table 31;

f_{cu} is the characteristic cube strength of concrete;

L_s is the length of the shear plane under consideration;

v_1 is the ultimate longitudinal shear stress in the concrete for the shear plane under consideration, taken from Table 31;

A_e is the area of fully anchored (see 5.8.6) reinforcement per unit length crossing the shear plane under consideration. Reinforcement provided for coexistent bending effects and shear reinforcement crossing the shear plane, provided to resist vertical shear (see 7.4.2.2), may be included provided it is fully anchored;

f_y is the characteristic strength of the reinforcement.

For composite beam and slab construction, a minimum area of fully anchored reinforcement of 0.15 % of the area of the contact should cross this surface; the spacing of this reinforcement should not exceed the lesser of the following:

- a) four times the minimum thickness of the in situ concrete flange;
- b) 600 mm.

The types of surface are defined as follows.

Type 1. The contact surface of the concrete in the precast members should be prepared as described in either 1) or 2) as appropriate.

1) Where the concrete has set but not hardened, the surface should be sprayed with a fine spray of water or brushed with a stiff brush, just sufficient to remove the outer mortar skin and expose the larger aggregate without disturbing it.

2) Where the treatment in 1) has proved impracticable the surface skin and laitance should be removed by sand blasting or the use of a needle gun and not by hacking.

Type 2. The contact surface of the concrete in the precast member should be jetted with air and/or water to remove laitance and all loose material. No further roughening need be carried out. (This type of surface is known as "rough as cast".)

For inverted T beams defined in 7.4.2.2 b) no longitudinal shear strength check is required.

7.4.3 Serviceability limit state

7.4.3.1 General. In addition to the recommendations given in clauses 5 and 6 concerned with control of cracking, the design of composite construction will be affected by 7.4.3.4 and 7.4.3.5 and, where prestressed precast units are used, also by 7.4.3.2 and 7.4.3.3.

7.4.3.2 Compression in the concrete. For composite members comprising prestressed precast units and in situ concrete, the methods of analysis may be as given in 6.3.2. However, where ultimate failure of the composite unit would occur due to excessive elongation of the steel, the maximum concrete compressive stress at the upper surface of the precast unit may be increased above the values given in Table 22 by up to 25 %.

7.4.3.3 Tension in the concrete. When the composite member considered in design comprises prestressed precast concrete units and in situ concrete, and flexural tensile stresses are induced in the in situ concrete by sagging moments due to imposed service loading, the tensile stresses in the in situ concrete at the contact surface should be limited to the values given in Table 32. These values may, however, be increased by 50 %, provided the permissible tensile stress in the prestressed concrete unit is reduced by the same numerical amount.

Table 31 — Ultimate longitudinal shear stress, v_1 , and values of k_1 for composite members

Type of shear plane	Longitudinal shear stress for concrete grade				k_1
	20	25	30	40 or more	
	N/mm ²	N/mm ²	N/mm ²	N/mm ²	
Monolithic construction	0.90	0.90	1.25	1.25	0.15
Surface type 1	0.50	0.63	0.75	0.80	0.15
Surface type 2	0.30	0.38	0.45	0.50	0.09

NOTE For construction with lightweight aggregate concrete, the values given in this table should be reduced by 25 %.

Where in situ concrete in the tension zone is shown by tests to contribute to the load distribution properties of a deck and is not taken into account in stress calculations, the notional tensile stress need not be calculated.

When the in situ concrete is not in direct contact with a prestressed precast unit, the flexural tensile stresses in the in situ concrete should be limited by cracking considerations in accordance with 5.8.8.2.

Table 32 — Flexural tensile stresses in in situ concrete

Grade of in situ concrete	25	30	40	50
Maximum tensile stress (N/mm ²)	3.2	3.6	4.4	5.0

Where continuity is obtained with reinforced concrete cast in situ over the supports, the flexural tensile stresses or the hypothetical tensile stresses in the prestressed precast units at the supports should be limited in accordance with 6.3.2.4.

7.4.3.4 Differential shrinkage. The effects of differential shrinkage should be considered for composite concrete construction where there is a difference between the age and quality of the concrete in the components. Differential shrinkage may lead to increased stresses in the composite section and these should be investigated. The effects of differential shrinkage are likely to be more severe when the precast component is of reinforced concrete or of prestressed concrete with an approximately triangular distribution of stress due to prestress. The stresses resulting from the effects of differential shrinkage may be neglected in inverted T beams with a solid infill deck, provided that the difference in concrete strengths between the precast and infill components is not more than 10 N/mm². For other forms of composite construction, the effects of differential shrinkage should be considered in design.

In computing the tensile stresses, a value will be required for the differential shrinkage strain (the difference in total free strain between the two components of the composite member), the magnitude of which will depend on a great many variables.

For a bridge in a normal environment and in the absence of more exact data, the value of shrinkage strain given in 6.7.2.4 should be used to compute stresses in composite construction. Reference should be made to Appendix C when using lightweight aggregate concrete.

The effects of differential shrinkage will be reduced by creep and the reduction coefficient may be taken as 0.43. Where more exact or intermediate values are necessary Appendix C should be used.

7.4.3.5 Continuity in composite construction. When continuity is obtained in composite construction by providing reinforcement over the supports, consideration should be given to the secondary effects of differential shrinkage and creep on the moments in continuous beams and on the reactions at the supports. The hogging restraint moment, M_{cs} , at an internal support of a continuous composite beam and slab section due to differential shrinkage should be taken as:

$$M_{cs} = \varepsilon_{diff} E_{cf} A_{cf}^a \phi \quad \text{equation 33}$$

where

- ε_{diff} is the differential shrinkage strain;
- E_{cf} is the modulus of elasticity of the flange concrete;
- A_{cf} is the area of the effective concrete flange;
- a_{cent} is the distance of the centroid of the concrete flange from the centroid of the composite section;
- ϕ is a reduction coefficient to allow for creep, taken as 0.43.

The restraint moment, M_{cs} , will be modified with time by creep due to dead load and creep due to any prestress in the precast units. The restraint moment due to prestress may be taken as the restraint moment which would have been set up if the composite section as a whole had been prestressed, multiplied by a creep coefficient, ϕ_1 , taken as 0.87.

The information given in CEB/FIP international recommendations on differential shrinkage, as given in Appendix C, should be used in assessing a value for the differential shrinkage strain.

The expressions given in the preceding paragraphs for calculating the restraint moments due to creep and differential shrinkage are based on an assumed value of 2.0 for the ratio, β_{cc} , of total creep to elastic deformation. If the design conditions are such that this value is significantly low, then the Engineer should calculate values for the reduction coefficients from the expressions:

$$\phi = [1 - e^{-\beta_{cc}}]/\beta_{cc} \quad \text{equation 34}$$

$$\phi_1 = [1 - e^{-\beta_{cc}}] \quad \text{equation 35}$$

where e is the base of Napierian logarithms.

7.5 Plain concrete walls and abutments

7.5.1 General. A plain concrete wall or abutment is a vertical load bearing concrete member whose greatest lateral dimension is more than four times its least lateral dimension and which is assumed to be without reinforcement when considering its strength.

The recommendations given in 7.5.2 to 7.5.10 refer to the design of a plain concrete wall that has a height not exceeding five times its average thickness.

7.5.2 Moments and forces in walls and abutments. Moments, shear forces and axial forces in a wall should be determined in accordance with 4.4.

The axial force may be calculated on the assumption that the beams and slabs transmitting forces into it are simply supported.

The resultant axial force in a member may act eccentrically due to vertical loads not being applied at the centre of the member or due to the action of horizontal forces. Such eccentricities should be treated as indicated in 7.5.3 and 7.5.4.

The minimum moment in a direction at right-angles to the wall should be taken as not less than that produced by considering the ultimate axial load per unit length acting at an eccentricity of 0.05 times the thickness of the wall.

7.5.3 Eccentricity in the plane of the wall or abutment.

In the case of a single member this eccentricity can be calculated from statics alone. Where a horizontal force is resisted by several members, the amount allocated to each member should be in proportion to its relative stiffness provided the resultant eccentricity in any individual member is not greater than one-third of the length of the member. Where a shear connection is assumed between vertical edges of adjacent members an appropriate elastic analysis may be used, provided the shear connection is designed to withstand the calculated forces.

7.5.4 Eccentricity at right-angles to walls or abutments.

The load transmitted to a wall by a concrete deck may be assumed to act at one-third the depth of the bearing area from the loaded face. Where there is an in situ concrete deck on either side of the member the common bearing area may be assumed to be shared equally by each deck.

The resultant eccentricity of the total load on a member unrestrained in position at any level should be calculated making full allowance for the eccentricity of all vertical loads and the overturning moments produced by any lateral forces above that level.

The resultant eccentricity of the total load on a member restrained in position at any level may be calculated on the assumption that immediately above a lateral support the resultant eccentricity of all the vertical loads above that level is zero.

7.5.5 Analysis of section. Loads of a purely local nature (as at beam bearings or column bases) may be assumed to be immediately dispersed provided the local stress under the load does not exceed that given in 7.5.7. Where the resultant of all the axial loads acts eccentrically in the plane of the member, the ultimate axial load per unit length of wall, n_w , should be assessed on the basis of an elastic analysis assuming a linear distribution of load along the length of the member, assuming no tensile resistance. Consideration should first be given to the axial force and bending in the plane of the wall to determine the distribution of tension and compression along the wall. The bending moment at right-angles to the wall should then be considered and the section checked for this moment and the compression or tension per unit length at various positions along the wall. Where the eccentricity of load in the plane of the member is zero, a uniform distribution of n_w may be assumed.

For members restrained in position, the axial load per unit length of member, n_w , due to ultimate loads should be such that:

$$n_w \leq (h - 2e_x) \lambda_w f_{cu} \quad \text{equation 36}$$

where

- n_w is the maximum axial load per unit load of member due to ultimate loads;
- h is the overall thickness of the section;
- e_x is the resultant eccentricity of load at right-angles to the plane of the member (see 7.5.2) (minimum value $0.05h$);
- f_{cu} is the characteristic cube strength of the concrete;
- λ_w is a coefficient, taken as 0.35 for concrete grades 15 and 20 and 0.4 for concrete grades 25 and above.

7.5.6 Shear. The resistance to shear forces in the plane of the member may be assumed to be adequate provided the horizontal shear force due to ultimate loads is less than either one-quarter of the vertical load, or the force to produce an average shear stress of 0.45 N/mm^2 over the whole cross section of the member in the case of concrete grade 25 or above; where grade 10, 15 or 20 concrete is used, a figure of 0.3 N/mm^2 is appropriate.

7.5.7 Bearing. Bearing stresses due to ultimate loads of a purely local nature, as at girder bearings, should be limited in accordance with 7.2.3.3.

7.5.8 Deflection of plain concrete walls or abutments. The deflection in a plain concrete member will be within acceptable limits if the preceding recommendations have been followed.

7.5.9 Shrinkage and temperature

reinforcement. For plain concrete members exceeding 2 m in length and cast in situ it is necessary to control cracking arising from shrinkage and temperature effects, including temperature rises caused by the heat of hydration released by the cement. Reinforcement should be provided in the direction of any restraint to such movement.

The area of reinforcement, A_s , parallel to the direction of each restraint should be such that:

$$A_s \geq k_r(A_c - 0.5A_{cor})$$

where

- k_r is 0.005 for grade 460 reinforcement and 0.006 for grade 250 reinforcement;
- A_c is the area of the gross concrete section at right-angles to the direction of the restraint;
- A_{cor} is the area of the core of the concrete section, A_c , i.e. that portion of the section more than 250 mm from all concrete surfaces.

Shrinkage and temperature reinforcement should be distributed uniformly around the perimeter of the concrete sections and spaced at not more than 150 mm.

7.5.10 Stress limitations for serviceability limit

state. The wall should be designed so that no tensile stresses are developed and the concrete compressive stresses comply with Table 2.

Appendix A Methods of compliance with serviceability criteria by direct calculation

A.1 Analysis of structure for serviceability limit states

In general it will be sufficiently accurate to assess the moments and forces in members subjected to their appropriate loadings for the serviceability limit states by using an elastic analysis. Greater accuracy may be achieved in this analysis if the relative stiffnesses of the members are assessed on the basis of the cracked, transformed section properties of the member at its mid-span or mid-height. In assessing the second moment of area of sections, due account may be taken of the effects of any axial loads on the members and the modulus of elasticity of the concrete should be as given in 4.3.2.1.

A.2 Calculation of deflections

A.2.1 General. When the deflections of reinforced concrete members are calculated, it should be realized that there are a number of factors which may be difficult to allow for in the calculation but which can have a considerable effect on the reliability of the result. For example:

- a) estimates of the restraints provided by supports are based on simplified and often inaccurate assumptions;
- b) the precise loading, or that part of it which is of long duration, cannot be accurately determined;
- c) lightly reinforced members may well have a working load that is close to the cracking load for the member; considerable differences will occur in the deflections depending on whether the member has or has not cracked.

The method of calculation given in A.2.2 and A.2.3, while not the only acceptable method, is one that will give reasonable results for both short term and long term loading (provided points such as those listed above have been correctly accounted for) and may be logically applied over a wide range of problems. The approach used is to assess the curvatures of sections under the appropriate moments and then calculate the deflections from the curvatures.

A.2.2 Calculation of curvatures. The curvature of any section may be calculated by employing whichever of the following sets of assumptions a) or b) gives the larger value. Assumption a) corresponds to the case where the section is cracked under the loading considered, b) applies to an uncracked section.

a) Strains are calculated on the assumption that plane sections remain plane.

The reinforcement, whether intension or in compression, is assumed to be elastic. Its modulus of elasticity may be taken as 200 kN/mm².

The concrete in compression is assumed to be elastic. Under short term loading, the modulus of elasticity may be taken as that given in 4.3.2.1. Under long term loading, an effective modulus may be taken having a value of 1/(1 + f) times the short term modulus, where f is the appropriate creep coefficient. See Appendix C.

Stresses in the concrete in tension may be calculated on the assumption that the stress distribution is triangular, having a value of zero at the neutral axis and a value at the centroid of the tension steel of 1 N/mm² instantaneously reducing to 0.55 N/mm² in the long term.

b) The concrete and the steel are both considered to be fully elastic in tension and in compression. The elastic modulus of the steel may be taken as 200 kN/mm² and the elastic modulus of the concrete is as given in paragraph three of (a) both in compression and in tension.

In assessing the total long term curvature of a section, the following procedure may be adopted.

Calculate the instantaneous curvatures under the total load and under the permanent load.

Calculate the long term curvature under the permanent load.

Add to the long term curvature under the permanent load the difference between the instantaneous curvatures under the total and permanent loads.

Add to the curvature the shrinkage curvature calculated from the formula:

$$\frac{1}{r_{cs}} = \rho_o \varepsilon_{cs} / d$$

where

$1/r_{cs}$ is the shrinkage curvature;

ε_{cs} is the free shrinkage strain in the assessment of which allowance should be made for the shape of the section;

d is the effective depth to tension reinforcement;

ρ_o is a coefficient which depends upon the percentages of tension and compression steel in the section. Values of ρ_o can be obtained from Table 33.

It is occasionally useful to be able to calculate the amount of creep or shrinkage curvature at some specific time after loading. This may be assessed by reference to Appendix C.

A.2.3 Calculation of deflection from

curvatures. The deflected shape of a member is related to the curvatures by the equation:

$$\frac{1}{r_x} = d^2 a / dx^2$$

where

$1/r_x$ is the curvature at x ;

a is the deflection at x .

Deflections may be calculated directly from this equation by calculating the curvatures at successive sections along the member and using a numerical integration technique such as that proposed by Newmark. Alternatively, the following simplified approach may be used.

The deflection is calculated from the equation:

$$a = K_1 l^2 \frac{1}{r_b}$$

where

a is the deflection;

l is the effective span of the member;





$\frac{1}{r_b}$ is the curvature at mid-span, or, for cantilevers, at the support section;

K_1 is a constant which depends on the shape of the bending moment diagram and relates the deflection at the required point to the curvature. Values of K_1 are given in Table 34.

Table 33 — Values of ρ_0 for calculation of shrinkage curvatures

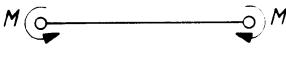
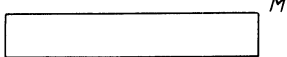
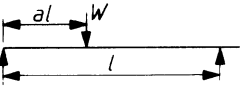
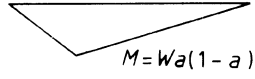
$\frac{100A_s}{bd}$	$\frac{100A'_s}{bd}$								
	0.00	0.25	0.50	0.75	1.00	1.25	1.50	1.75	2.00
0.25	0.44	0.31	0.26	0.22	0.20	0.18	0.17	0.16	0.15
0.50	0.56	0.31	0.26	0.22	0.20	0.18	0.17	0.16	0.15
0.75	0.64	0.45	0.26	0.22	0.20	0.18	0.17	0.16	0.15
1.00	0.70	0.55	0.39	0.22	0.20	0.18	0.17	0.16	0.15
1.50	0.80	0.69	0.57	0.45	0.32	0.18	0.17	0.16	0.15
2.00	0.88	0.79	0.69	0.60	0.49	0.39	0.28	0.16	0.15
2.50	0.95	0.87	0.79	0.70	0.62	0.53	0.44	0.35	0.25
3.00	1.00	0.94	0.86	0.79	0.72	0.64	0.57	0.49	0.40
3.50	1.00	1.00	0.93	0.87	0.80	0.74	0.67	0.60	0.52
4.00	1.00	1.00	1.00	0.93	0.87	0.81	0.75	0.69	0.62

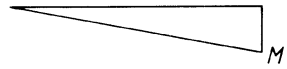
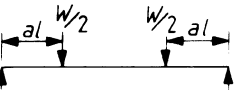
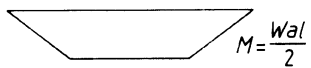
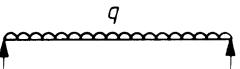
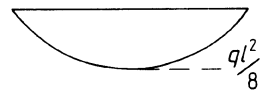
Table 34 — Values of K_1 for various bending moment diagrams

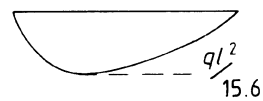
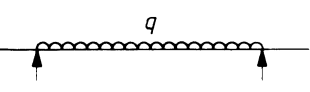
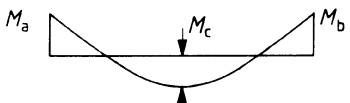
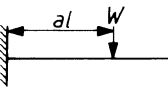
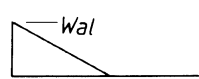
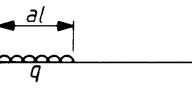
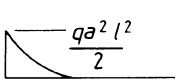
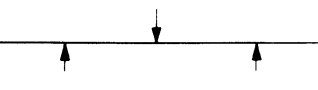
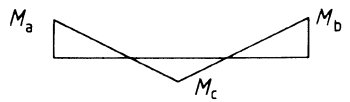
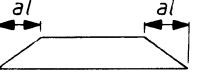
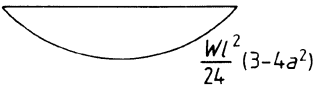
Loading	Bending moment diagram	K_1
		0.125
		$\frac{4a^2 - 8a + 1}{48a}$ if $a = 1/2$ $K_1 = 1/12$
		0.0625
		$0.125 - \frac{\alpha^2}{6}$
		0.104
		0.102
		$K_1 = 0.104 \left(1 - \frac{\beta}{10}\right)$ $\beta = \frac{M_a + M_b}{M_c}$
		end deflection $= \frac{a(3-a)}{6}$ load at end $K_1 = 0.333$
		$\frac{a(4-a)}{12}$ if $a = 1$ $K_1 = 0.25$
		$K_1 = 0.083 \left(1 - \frac{\beta}{4}\right)$ $\beta = \frac{M_a + M_b}{M_c}$
		$\frac{1}{80} \frac{(5 - 4a^2)^2}{3 - 4a^2}$

Appendix B Elastic deformation of concrete

The modulus of elasticity is primarily dependent on the crushing strength of the concrete. It is, however, influenced by the elastic properties of the aggregate and to a lesser extent by the conditions of curing and age of concrete, the mix proportions and the type of cement. For concrete made with natural aggregates and having a density of 2 300 kg/m³ or more, the static or dynamic modulus of elasticity may be taken from Table 35 for concrete of various compressive strengths.

Table 35 — Modulus of elasticity

Compressive strength, f_{cu}	Static modulus, E_c		Dynamic modulus, E_{cq}	
	Mean value	Typical range	Mean value	Typical range
N/mm ²	kN/mm ²	kN/mm ²	kN/mm ²	kN/mm ²
20	25	21 to 29	35	31 to 39
25	26	22 to 30	36	32 to 40
30	28	23 to 33	38	33 to 43
40	31	26 to 36	40	35 to 45
50	34	28 to 40	42	36 to 48
60	36	30 to 42	44	38 to 50

If a more accurate figure is required for particular materials and a particular mix, tests should be made in accordance with BS 1881. Concretes made from a few particular sources of aggregate may have a modulus of elasticity substantially outside the range given in Table 35. The use of these materials may be permitted provided the appropriate value for elastic modulus obtained from tests is used in design calculations.

It may be convenient to use the dynamic modulus method of test to obtain an estimated value for the static modulus using the formula:

$$E_c = 1.25E_{cq} - 19.$$

Such an estimated value will generally be correct within ± 4 kN/mm².

For lightweight aggregate concrete having a density between 1 440 kg m³ and 2 300 kg/m³, the values of static modulus given in Table 35 should be multiplied by ($D_c/2\ 300$), where D_c is the density of the lightweight aggregate concrete in kg/m³.

Alternatively, the value of the elastic modulus for a specific strength may be obtained from the lightweight aggregate producer.

Neither the equation nor the data given in Table 35 relating to the dynamic modulus of elasticity is applicable to lightweight aggregate concrete.

Appendix C Shrinkage and creep

C.1 General

Shrinkage and creep affect deformation and stresses in many structures. The effect depends on the inherent shrinkage and creep of the concrete, on the size of the members, and on the amount and distribution of reinforcement.

The information given in C.2 and C.3 is essentially that given in CEP/FIP International Recommendations for the Design and Construction of Concrete Structures, 1970 as amended in May 1972, but to assess the behaviour of reinforced or prestressed concrete, the succeeding sections have to be taken into account. The CEP/FIP data are valid only for Portland cement concretes of normal quality, hardening under normal conditions and subject to service stresses at the most equal to 40 % of the ultimate strength. The data are no more than a working basis. In particular, the type of aggregate may seriously affect the magnitude of shrinkage and creep, sandstone generally leading to a high and limestone to a low deformation. The data in BRS digest no. 35 are of help.

C.2 Creep

In order to evaluate the order of magnitude of time-dependent deformations due to creep under working conditions, use may be made of the theory of linear creep. For a constant stress f_c , this theory leads to a calculation of the final creep deformation from the formula:

$$\Delta_{cc} = \frac{f_c}{E_{28}} \phi$$

In this formula, E_{28} is the value of the secant modulus of elasticity of the concrete at the age of 28 days, which gives an indication of the quality of the concrete, and ϕ is a coefficient covering the particular working conditions envisaged. This coefficient is equal to the product of five partial coefficients:

$$\phi = k_L k_m k_c k_e k_j$$

where

k_L depends on the environmental conditions (see Figure 9);

k_m depends on the hardening (maturity) of the concrete at the age of loading (see Figure 10);

k_c depends on the composition of the concrete (see Figure 11);

k_e depends on the effective thickness of the member (see Figure 12);

k_j defines the development of the time-dependent deformation with time (see Figure 13).

The value of ϕ calculated with the values of these different coefficients given in Figure 9 to Figure 13 is an average value. When creep has a large influence on the limit state under consideration, an increase or a reduction of the order of 15 % should be considered, so as to cover the most unfavourable case.

If the stresses producing creep are themselves influenced by creep, or if they vary in a continuous manner, it is necessary to use iterative methods or to revert to appropriate analytical methods.

Where creep has a very large effect on stresses, it may be advantageous to produce curves giving k_m and k_j from equations.

The degree of hardening of the concrete at the age of loading exerts an influence at least as large as the climatic conditions.

The values in Figure 10 refer to Portland cement, hardened under normal conditions, i.e. at an average content temperature of 20 °C and with protection against excessive loss of moisture.

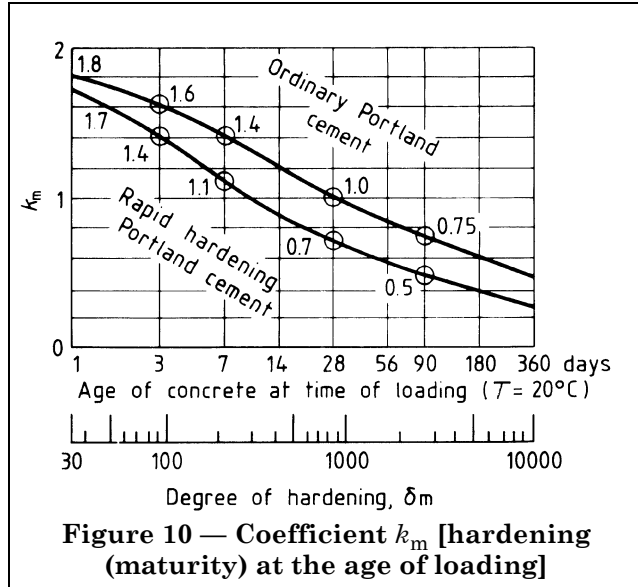

Figure 10 — Coefficient k_m [hardening (maturity) at the age of loading]

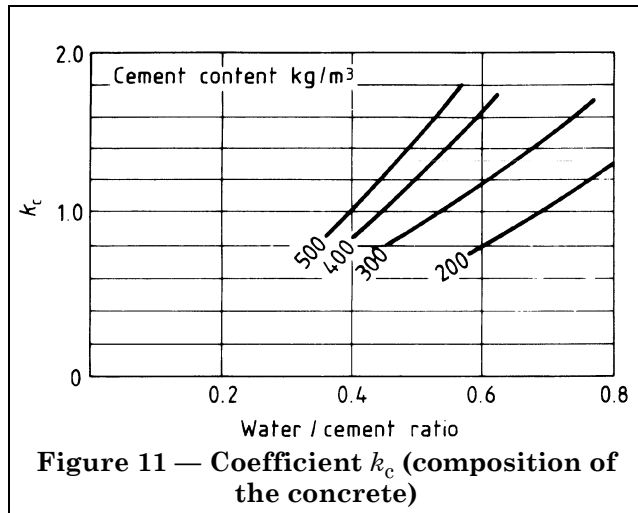

Figure 11 — Coefficient k_c (composition of the concrete)

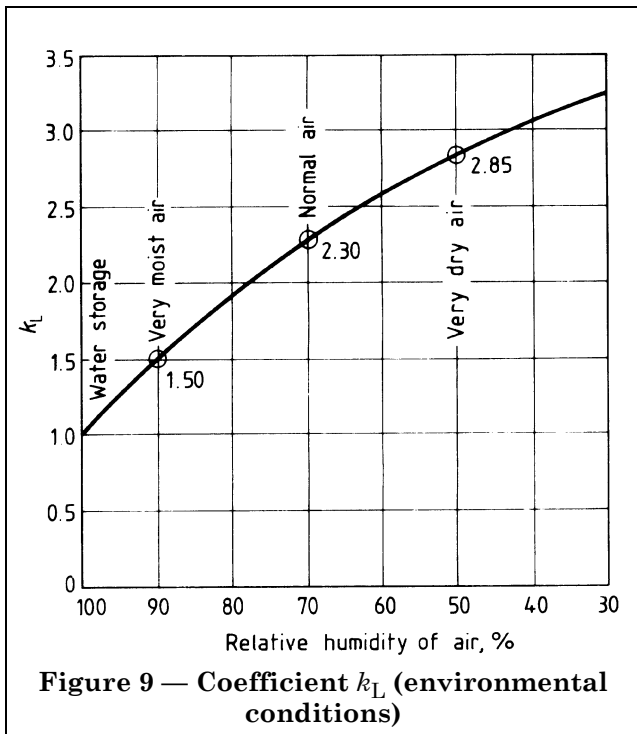
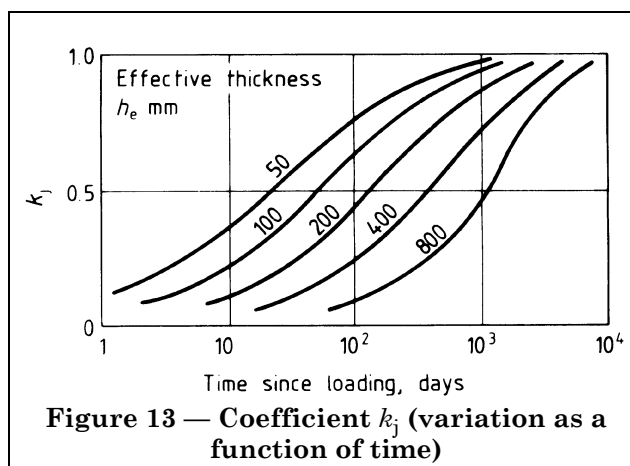
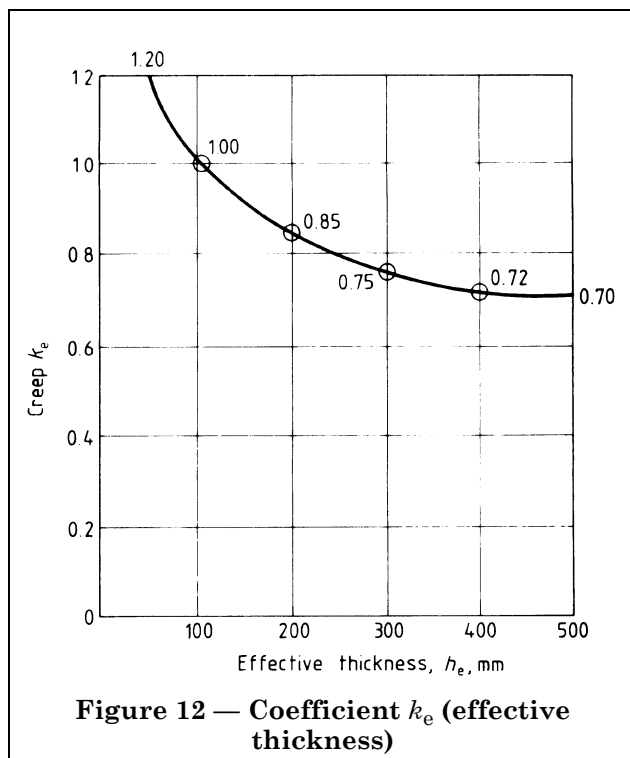

Figure 9 — Coefficient k_L (environmental conditions)



If the concrete hardens at a temperature other than 20 °C, the age at loading is replaced by the corresponding degree of hardening:

$$\delta_m = \sum j_m (T + 10^\circ)$$

where

δ_m represents the degree of hardening at the moment of loading;

j_m represents the number of days during which hardening has taken place at $T^\circ\text{C}$.

The effective thickness, h_e , is the ratio of the area of the section A to the semi-perimeter, $u/2$, in contact with the atmosphere. If one of the dimensions of the section under consideration is very large compared with the other, the effective thickness corresponds approximately to the actual thickness.

If the dimensions are not constant along the member, an average effective thickness can be defined by paying particular attention to those sections in which the stresses are highest.

In general, the final creep deformation, Δ_{cc} , for light-weight aggregate concretes is greater than that for normal aggregate concretes. This difference is a little less for high-strength concretes than for low-strength concretes and depends on the modulus of elasticity of the aggregate. The final creep deformation should be deduced from tests.

Alternatively, it may be calculated by giving E_{28} the value corresponding to normal aggregate concretes and by multiplying the result obtained by 1.6, i.e.:

$$\Delta_{cc} = \frac{1.6f_c}{E_{28}}$$

An accelerated method of determination of creep has been developed¹⁾.

At a given moment t , after application of the loads, the influence of a stress f_{cj} , applied at the instant j and subject at any moment i to variation in intensity f_{co} , may be expressed as:

$$\Delta_{cct} = \frac{1}{E_{28}} [f_{cj}\phi_{(t-j)} + \sum f_{co}\phi_{(t-i)}]$$

or

$$\Delta_{cct} = \frac{k_L k_c k_e}{E_{28}} [f_{cj} k_m j k_j(t-j) + \sum f_{co} k_m i k_j(t-i)]$$

where Δ_{cct} is the resulting strain.

As shown in the equation, superposition of loads should always be done on the assumption that the stress applied at the beginning operates until the end of the period under consideration. The same method may be applied for all later stress changes; in effect, the values of k_m have been determined by these hypotheses.

¹⁾ NEVILLE, A.M. and LISZKA, W.Z., Accelerated determination of creep of lightweight aggregate concrete, *Civil Engineering*, June 1973, pp 515–519.

C.3 Shrinkage

The shrinkage deformation, Δ_{cs} , at any instant may be determined by the product of four partial coefficients

$$\Delta_{cs} = k_L k_c k_e k_j$$

where

- k_L depends on the environment;
- k_c depends on the composition of the concrete;
- k_e depends on the effective thickness of the member;
- k_j defines the development of shrinkage as a function of time.

In addition it is possible to add a coefficient for internal restraint, k_2 , which depends on the geometric ratio of longitudinal reinforcement, ρ .

As a general rule, Δ_{cs} as a function of k_2 gives the reduction in length of the fibre at the centre of gravity of the steel under consideration. The more detailed approach of C.4 is preferable.

The average values of the coefficients k_L , k_c , k_e and k_j , as functions of the parameters that define them, may be taken from the following diagrams which are valid only for concretes that have been protected from excessive losses of moisture in their early days.

For unreinforced concrete, the average values of k_L can be taken from Figure 14.

For embedded electric heating, values of the coefficient k_L should be based on experience.

For coefficient k_c (composition of the concrete), the same coefficients may be used as for creep.

Figure 15 gives the values, using the same definition of effective thickness, h_e , as for creep.

For coefficient k_j (variation as a function of time) the same coefficient may be used as for creep.

Where climatic conditions are constant, the deformation due to shrinkage in an interval of time ($t - i$) is equal to:

$$\Delta_{cs}(t - i) = k_L k_c k_e (k_{jt} - k_{ji})$$

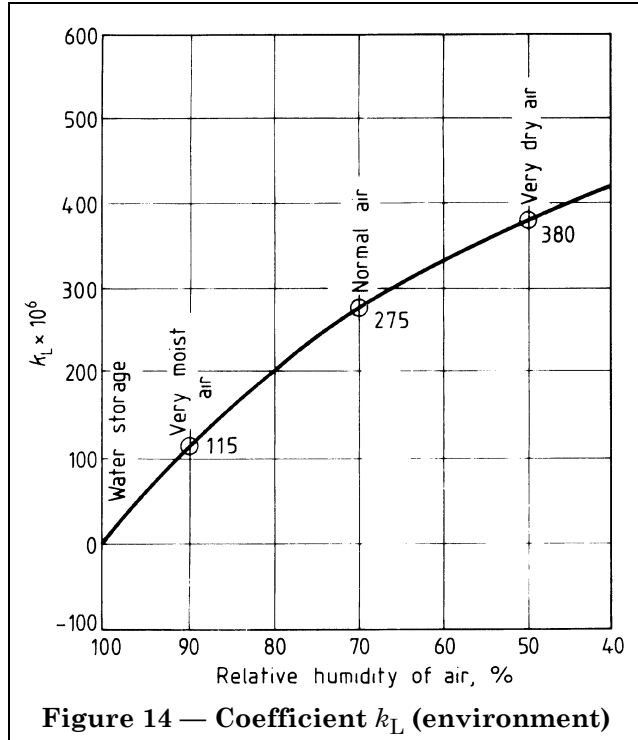

Figure 14 — Coefficient k_L (environment)

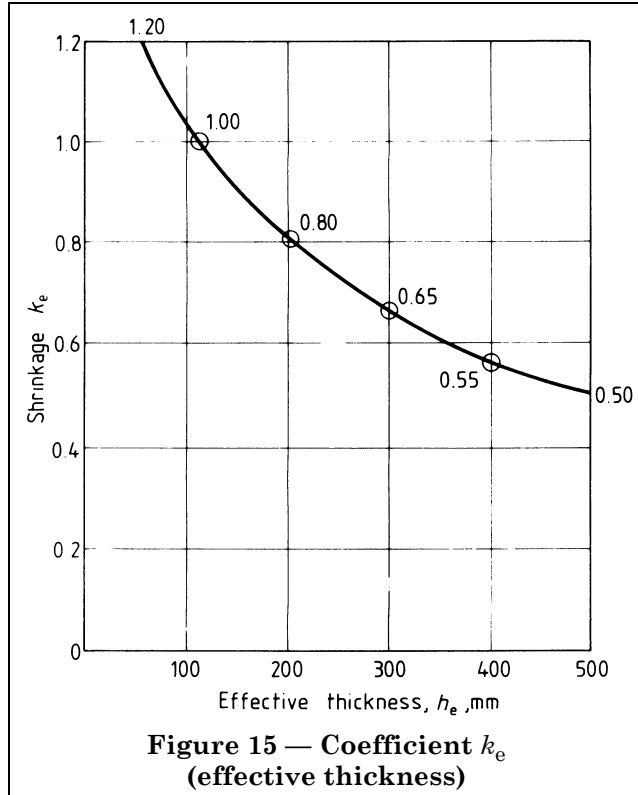

Figure 15 — Coefficient k_e (effective thickness)

At early ages, the shrinkage of a protected concrete is lower than that of an unprotected concrete (this is important when trying to avoid cracking in concrete that is young and therefore of low strength), the difference decreasing with time and finally vanishing. This feature is less noticeable in massive members.

It has been shown experimentally that shrinkage of structural lightweight concretes is between one and two times that of normal aggregate concretes with the same compressive strength.

Some natural aggregates, e.g. some Scottish dolerites, exhibit appreciable shrinkage; concrete made with such an aggregate will undergo greater shrinkage than predicted and appropriate precautions should be taken in design.

C.4 Reinforced concrete

The values given in C.3 apply to plain (unreinforced) concrete members. For structural members containing reinforcement, the magnitude of shrinkage and creep which can be realized is greatly reduced.

Various analytical methods may be used, but a practical method of computing directly the strain under a varying stress, or stress under a constant or varying strain, uses a relaxation coefficient:

$$\eta = \int_{j_i}^{j_\infty} \frac{df_{c_j}}{dj} \frac{1}{\Delta f_{c_\infty}} \frac{k_{mj}}{k_{mi}} dj$$

where

f_{c_j} is the stress in concrete at application of an increment of stress at time j ;

Δf_{c_∞} is the change in stress in concrete due to creep at time t_∞ ;

j is the age at application of increment of stress;

j_i is the age at first loading;

j_∞ is the age at the end of the life of the structure;

k_{mi} is the coefficient k_m for age at first loading.

For various values of $\phi_n = \phi/k_m$ the value of η can be obtained from Figure 16.

To calculate axial stresses or strains due to shrinkage the amount and position of reinforcement should be taken into account, the free shrinkage, i.e. that given by Δ_{cs} , being multiplied by an appropriate coefficient. For axially loaded symmetrically reinforced members this coefficient is:

$$\phi_2 = \frac{1}{1 + \rho \alpha_e [1 + \eta \phi]}$$

where

α_e is the modular ratio at first introduction of stress;

ρ is the geometrical ratio of reinforcement.

The values of ϕ_2 as a function of $\rho \alpha_e$ and $\eta \phi$ are shown in Figure 17.

For singly reinforced concrete members, the creep reduction coefficient that is applied to free shrinkage in order to calculate the shortening at the level of reinforcement is:

$$\phi_3 = \frac{1}{1 + \rho \alpha_e (1 + a_s^2 / i^2) [1 + \eta \phi]}$$

where

i is the radius of gyration of the net concrete section;

a_s is the distance of the centroid of the steel from the centroid of the net concrete section.

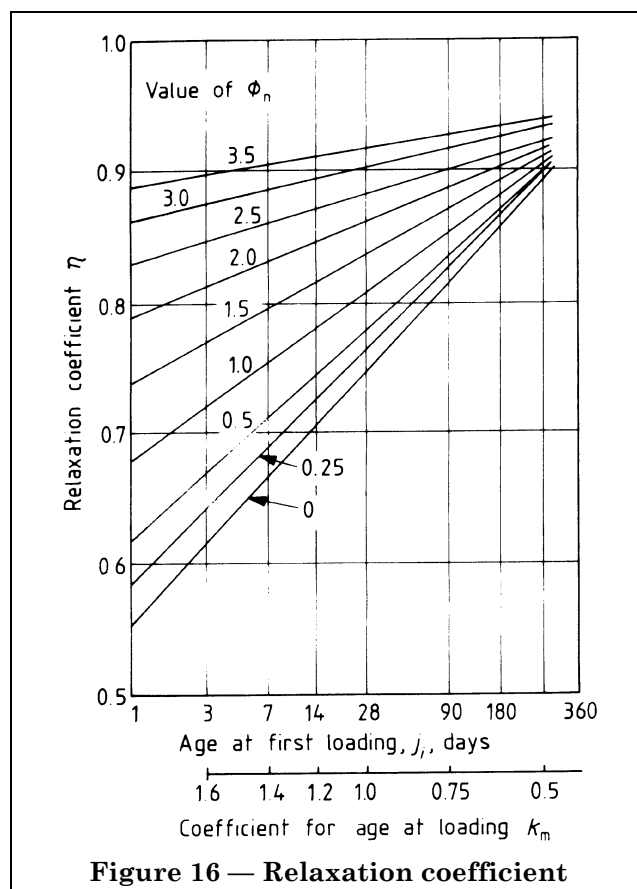

Figure 16 — Relaxation coefficient

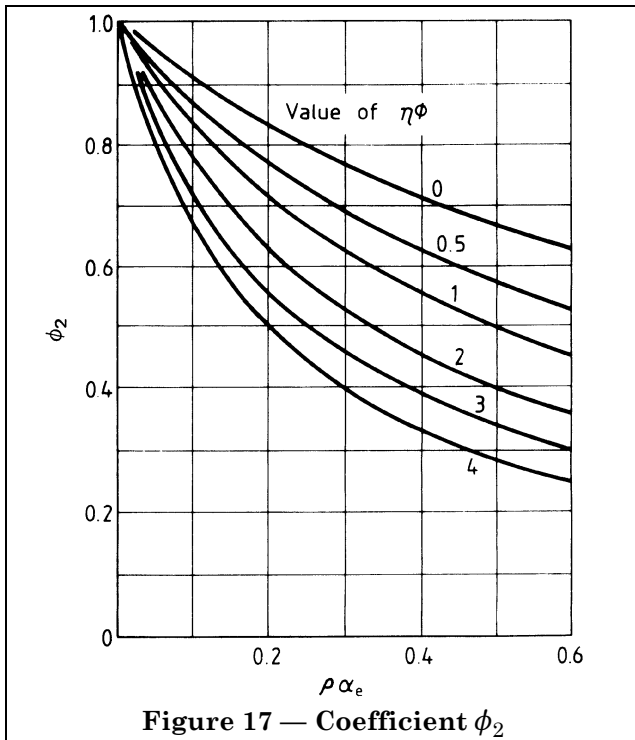

Figure 17 — Coefficient ϕ_2

The values of ϕ_3 at two levels of a_s/i , corresponding in rectangular beams to a_s/h (a_s /total depth of section) equal to 0.40 and 0.45, are shown in Figure 18 and Figure 19.

The change in stress due to creep in a reinforced concrete beam subjected to a bending moment is that induced by the moment at its application times a coefficient, which is for symmetrically reinforced symmetrical sections:

$$\phi_4 = \frac{1}{1 + \rho\alpha_e[1 + \eta\phi] a_s^2/i^2}$$

and for singly reinforced sections:

$$\phi_5 = \frac{\rho\alpha_e}{1 + \rho\alpha_e} + \frac{1 + \rho\alpha_e[1 + \eta\phi]}{1 + \rho\alpha_e(1 + a_s^2/i^2)[1 + \eta\phi](1 + \rho\alpha_e)}$$

Further analyses have been published²⁾.

C.5 Prestressed concrete

Prestressed concrete can be considered as a more general case of reinforced concrete but the presence of prestress makes the effects of shrinkage and creep especially significant.

- a) In post-tensioned members with bonded steel, the loss of prestress due to shrinkage and creep at time t can be calculated from:

$$\Delta_p = \frac{\alpha_e f_{co} \phi_{ti} + \Delta_{cst} E_s}{1 + \rho\alpha_e(1 + a_s^2/i^2)[1 + \eta\phi_{ti}]}$$

where

f_{co} is the stress in concrete at the level of the tendon due to initial prestress and dead load;

Δ_{cst} is the shrinkage at time t ;

ϕ_{ti} is the creep coefficient at time t for a load applied at time i .

The loss due to relaxation of steel has to be added to the preceding loss.

In pre-tensioned members, there are additional losses of prestress due to shrinkage between setting of concrete and transfer and due to relaxation between stressing and transfer.

The preceding approach assumes a constant value of the modulus of elasticity of concrete from the time of prestressing onward and a shrinkage time function of the same form as the creep time function for the coefficient k_j . If these assumptions are not reasonable, a step-by-step procedure may be used.

- b) Non-prestressed steel should be taken into account in considering the effects of shrinkage and creep if the second moment of the transformed area of the non-prestressed steel about the centroid of the concrete section represents a significant proportion (say, 10 %) of the second moment of the concrete section alone. While the creep and shrinkage losses are reduced by the presence of the non-prestressed steel, the converse is the case for the relaxation loss because the elastic and creep recoveries are smaller in the presence of the additional steel.

With single-layer prestressing, the creep reduction coefficients ϕ_2 , ϕ_3 or ϕ_4 can be used to allow for the presence of non-prestressed steel. These coefficients are determined on the basis of the non-prestressed steel alone.

²⁾ Reference can be made to "Creep of concrete: plain reinforced and prestressed", by Prof. A.M. Neville. North Holland Publishing Co 1970, 622 pp.

c) The change in the curvature of a prestressed member due to creep is:

$$\phi = \frac{1}{a_s} \left[\frac{1 + \rho\alpha_e(1 + \eta\phi)}{1 + \rho\alpha_e(1 + a_s^2/j^2)(1 + \eta\phi)} \epsilon_{c1} - \epsilon_{c2} \right]$$

where

ϵ_{c1} is the creep strain in concrete at the level of the tendon due to initial prestress and dead load;

ϵ_{c2} is the creep strain in concrete at the centroid of the section due to initial prestress and dead load.

Deflection due to creep can be calculated from the change in curvature in the usual manner.

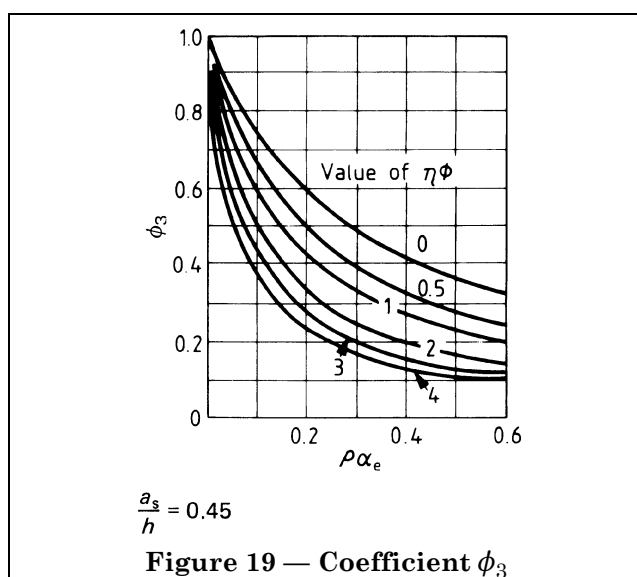
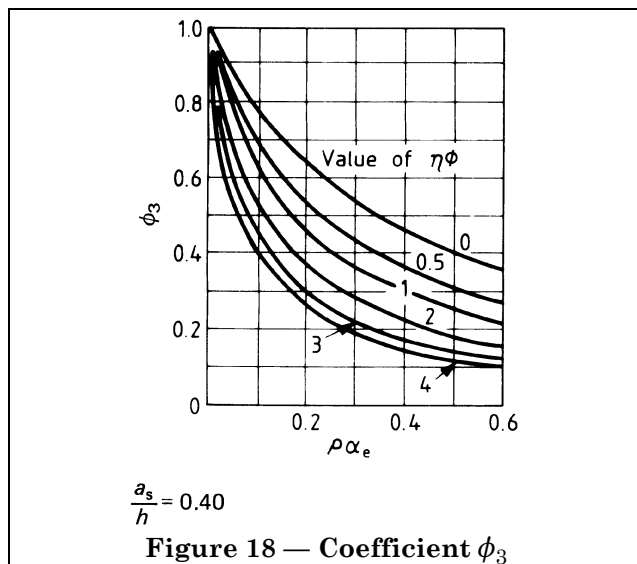

Appendix D Cover and spacing of curved tendons in ducts for prestressed concrete

D.1 General

Where curved tendons are used in post-tensioning, the positioning of the tendon ducts and the sequence of tensioning should be such as to prevent:

- bursting of the side cover perpendicular to the plane of curvature of ducts;
- bursting of the cover in the plane of curvature of the ducts;
- crushing of the concrete separating tendons in the same plane of curvature.

Pending the availability of further research data the following rules given in **D.2** and **D.3** may be applied.

D.2 Cover

In order to prevent bursting of the cover:

- perpendicular to the plane of curvature,
- in the plane of curvature, e.g. where the curved tendons run close to and approximately parallel to the surface of a member,

the cover should be in accordance with the values given in Table 36. Where tendon profilers or spacers are provided in the ducts, and these are of a type which will concentrate the radial force, the values given in Table 36 will need to be increased.

The cover for a given combination of duct internal diameter and radius of curvature shown in Table 36 may be reduced pro rata with the square root of the tendon force when this is less than the value tabulated, subject to the recommendations of **6.8.2.3**.

When detail b) above is used and the tendon develops radial forces perpendicular to the exposed surface of the concrete, the duct should be restrained by stirrup reinforcement anchored into the members.

D.3 Spacing

In order to prevent crushing of the concrete between ducts minimum spacing should be as follows.

- In the plane of curvature: the values given in Table 37 or the value given in 6.8.3.3, whichever is the greater.
- Perpendicular to the plane of curvature: in accordance with the recommendations of 6.8.3.3. Where tendon profilers or spacers are provided in the ducts, and these are of a type which will concentrate the radial force, the values given in Table 37 will need to be increased. If necessary, reinforcement should be provided between ducts.

The distance for a given combination of duct internal diameter and radius of curvature shown in Table 37 may be reduced pro rata with the tendon force when this is less than the value tabulated, subject to the recommendations of 6.8.3.3.

Exceptionally, to achieve minimum spacing of ducts it may be possible to tension and grout first the tendon having the least radius of curvature, and to allow an interval of 48 h to elapse before tensioning the next tendon. In this case the spacing recommendations given in 6.8.3.3 apply.

Table 36 — Minimum cover to ducts perpendicular to plane of curvature, in millimetres

Radius of curvature of duct (m)	Duct internal diameter (mm)															
	19	30	40	50	60	70	80	90	100	110	120	130	140	150	160	170
	Tendon force (kN)															
	296	387	960	1 337	1 920	2 640	3 360	4 320	5 183	6 019	7 200	8 640	9 424	10 336	11 248	13 200
2	50	55	155	220	320	445										
4		50	70	100	145	205	265	350	420							
6			50	65	90	125	165	220	265	310	375	460				
8				55	75	95	115	150	185	220	270	330	360	395		
10				50	65	85	100	120	140	165	205	250	275	300	330	
12					60	75	90	110	125	145	165	200	215	240	260	315
14					55	70	85	100	115	130	150	170	185	200	215	260
16					55	65	80	95	110	125	140	160	175	190	205	225
18					50	65	75	90	105	115	135	150	165	180	190	215
20						60	70	85	100	110	125	145	155	170	180	205
22						55	70	80	95	105	120	140	150	160	175	195
24						55	65	80	90	100	115	130	145	155	165	185
26						50	65	75	85	100	110	125	135	150	160	180
28							60	75	85	95	105	120	130	145	155	170
30							60	70	80	90	105	120	130	140	150	165
32							55	70	80	90	100	115	125	135	145	160
34							55	65	75	85	100	110	120	130	140	155
36							55	65	75	85	95	110	115	125	140	150
38							50	60	70	80	90	105	115	125	135	150
40	50	50	50	50	50	50	50	60	70	80	90	100	110	120	130	145

NOTE The tendon force shown is the maximum normally available for the given size of duct. (Taken as 80 % of the characteristic strength of the tendon.)

Table 37 — Minimum distance between centre lines of ducts in plane of curvature, in millimetres

Radius of curvature of duct (m)	Duct internal diameter (mm)															
	19	30	40	50	60	70	80	90	100	110	120	130	140	150	160	170
	Tendon force (kN)															
	296	387	960	1 337	1 920	2 640	3 360	4 320	5 183	6 019	7 200	8 640	9 424	10 336	11 248	13 200
2	110	140	350	485	700	960										
4	55	70	175	245	350	480	610	785	940							Radii not normally used
6	38	60	120	165	235	320	410	525	630	730	870	1040				
8			90	125	175	240	305	395	470	545	655	785	855	940		
10			80	100	140	195	245	315	375	440	525	630	685	750	815	
12						160	205	265	315	365	435	525	570	625	680	800
14						140	175	225	270	315	375	450	490	535	585	785
16							160	195	235	275	330	395	430	470	510	600
18								180	210	245	290	350	380	420	455	535
20									200	220	265	315	345	375	410	480
22											240	285	310	340	370	435
24												265	285	315	340	400
26 ^c												260	280	300	320	370
28																345
30																340
32																
34																
36																
38																
40	38	60	80	100	120	140	160	180	200	220	240	260	280	300	320	340

NOTE 1 The tendon force shown is the maximum normally available for the given size of duct. (Taken as 80 % of the characteristic strength of the tendon.)

NOTE 2 Values less than 2 × duct internal diameter are not included.

Publications referred to

- BS 499, *Welding terms and symbols*.
- BS 1881, *Methods of testing concrete*.
- BS 4190, *Specification for ISO metric black hexagon bolts, screws and nuts*.
- BS 4447, *Specification for the performance of prestressing anchorages for post-tensioned construction*.
- BS 4449, *Specification for carbon steel bars for the reinforcement of concrete*.
- BS 4461, *Specification for cold worked steel bars for the reinforcement of concrete*.
- BS 4466, *Specification for bending dimensions and scheduling of bars for the reinforcement for concrete*.
- BS 4482, *Specification for cold reduced steel wire for the reinforcement of concrete*.
- BS 4486, *Specification for hot rolled and hot rolled and processed high tensile alloy steel bars for the prestressing of concrete*.
- BS 4757, *Specification for nineteen-wire steel strand for prestressed concrete*.
- BS 5400, *Steel, concrete and composite bridges*.
- BS 5400-1, *General statement*.
- BS 5400-2, *Specification for loads*.
- BS 5400-3, *Code of practice for design of steel bridges*.
- BS 5400-7, *Specification for materials and workmanship, concrete, reinforcement and prestressing tendons*.
- BS 5400-8, *Recommendations for materials and workmanship, concrete, reinforcement and prestressing tendons*.
- BS 5400-9, *Bridge bearings*.
- BS 5400-10, *Code of practice for fatigue*.
- BS 5896, *Specification for high tensile steel wire strand for the prestressing of concrete*.
- BS 8110, *Code of practice for the structural use of concrete*.
- BS 8110-1, *Code of practice for design and construction*.
- BS 8110-2, *Code of practice for special circumstances*.
- BS 8110-3, *Design charts for single reinforced beams, doubly reinforced beams and rectangular columns*.

BSI — British Standards Institution

BSI is the independent national body responsible for preparing British Standards. It presents the UK view on standards in Europe and at the international level. It is incorporated by Royal Charter.

Revisions

British Standards are updated by amendment or revision. Users of British Standards should make sure that they possess the latest amendments or editions.

It is the constant aim of BSI to improve the quality of our products and services. We would be grateful if anyone finding an inaccuracy or ambiguity while using this British Standard would inform the Secretary of the technical committee responsible, the identity of which can be found on the inside front cover. Tel: 020 8996 9000. Fax: 020 8996 7400.

BSI offers members an individual updating service called PLUS which ensures that subscribers automatically receive the latest editions of standards.

Buying standards

Orders for all BSI, international and foreign standards publications should be addressed to Customer Services. Tel: 020 8996 9001. Fax: 020 8996 7001.

In response to orders for international standards, it is BSI policy to supply the BSI implementation of those that have been published as British Standards, unless otherwise requested.

Information on standards

BSI provides a wide range of information on national, European and international standards through its Library and its Technical Help to Exporters Service. Various BSI electronic information services are also available which give details on all its products and services. Contact the Information Centre. Tel: 020 8996 7111. Fax: 020 8996 7048.

Subscribing members of BSI are kept up to date with standards developments and receive substantial discounts on the purchase price of standards. For details of these and other benefits contact Membership Administration. Tel: 020 8996 7002. Fax: 020 8996 7001.

Copyright

Copyright subsists in all BSI publications. BSI also holds the copyright, in the UK, of the publications of the international standardization bodies. Except as permitted under the Copyright, Designs and Patents Act 1988 no extract may be reproduced, stored in a retrieval system or transmitted in any form or by any means – electronic, photocopying, recording or otherwise – without prior written permission from BSI.

This does not preclude the free use, in the course of implementing the standard, of necessary details such as symbols, and size, type or grade designations. If these details are to be used for any other purpose than implementation then the prior written permission of BSI must be obtained.

If permission is granted, the terms may include royalty payments or a licensing agreement. Details and advice can be obtained from the Copyright Manager. Tel: 020 8996 7070.