

British Standard

A single copy of this
British Standard is licensed to
Giorgio Cavalieri
on November 15, 2000

This is an uncontrolled copy.
Ensure use of the most current
version of this standard by
searching British Standards Online
at bsonline.techindex.co.uk

CONFIRMED
MAY 1998

Guide to

Accuracy in building

Licensed Copy: Giorgio Cavalieri, none, 15-Nov-00, Uncontrolled Copy. © BSI

ICS 91.200

Committees responsible for this British Standard

The preparation of this British Standard was entrusted by the Basic Data and Performance Criteria for Civil Engineering and Building Structures Standards Policy Committee (BDB/-) to Technical Committee BDB/4, upon which the following bodies were represented:

Association of County Councils
 British Standards Society
 Building Employers' Confederation
 Chartered Institution of Building Services Engineers
 Concrete Society
 Department of Education and Science
 Department of the Environment (Property Services Agency)
 Department of the Environment (Building Research Establishment)
 Incorporated Association of Architects and Surveyors
 Institute of Building Control
 Institute of Clerks of Works of Great Britain Inc.
 Institution of Civil Engineers
 Institution of Structural Engineers
 Institution of Water and Environmental Management
 Royal Institute of British Architects
 Royal Institution of Chartered Surveyors

The following bodies were also represented in the drafting of the standard, through subcommittees and panels:

British Constructional Steelwork Association Ltd.
 Chartered Institute of Building

This British Standard, having been prepared under the direction of the Basic Data and Performance Criteria for Civil Engineering and Building Structures Standards Policy Committee, was published under the authority of the Standards Board and comes into effect on 30 September 1990

© BSI 05-1999

First published December 1976
 First revision September 1990

The following BSI references relate to the work on this standard:
 Committee reference BDB/4
 Draft for comment 86/12803 DC

ISBN 0 580 18657 1

Amendments issued since publication

Amd. No.	Date	Comments
9975	May 1998	Indicated by a sideline in the margin

Contents

	Page
Committees responsible	Inside front cover
Foreword	iii
<hr/>	
0 Introduction	1
Section 1. General	
1 Scope	2
2 Definitions	2
<hr/>	
Section 2. Problems of inaccuracy or fit associated with elements and components of construction	
3 General	3
4 Examples of typical problems	3
5 Designing out problems	6
<hr/>	
Section 3. Designing to achieve good fit and assembly	
6 General	14
7 Tolerances	14
8 Basic information and analysis of dimensional variability	14
9 Assessing the dimensional needs of a design	22
10 Specifying tolerances	25
<hr/>	
Section 4. Construction considerations	
11 Accuracy in construction	27
12 Sources of induced deviations	27
13 Control of accuracy during construction	27
<hr/>	
Appendix A Site surveys	29
Appendix B Examples of the calculation of tolerances	32
Appendix C Measured values of dimensional accuracy	37
Appendix D The BRE survey of constructed items	43
<hr/>	
Figure 1 — Diagrammatic section showing screed accommodating trunking and range of deviations involved	4
Figure 2 — Target sizes of lift well	5
Figure 3 — Diagrammatic plan showing dimensional variabilities relating to component, prepared space and joint	6
Figure 4 — Examples of deviation limits associated with items of construction	15
Figure 5 — Examples of deviations associated with manufactured components	22
Figure 6 — Diagrammatic section showing total height, minimum floor to ceiling height, floor edge line and level variability, and vertical setting out variability	24
Figure 7 — Minimum bearings and dry packings	24
Figure 8 — Schematic diagram indicating how the dimensional needs of a design can be assessed	26
Figure 9 — Target sizes for a prepared opening, single window and joints	33
Figure 10 — Rebated column	33
Figure 11 — Joint cover strip	33
Figure 12 — Target sizes for a prepared opening, three windows and joints	33
Figure 13 — Variability of face line of concrete nibs	34
Figure 14 — Variability of nib in relation to brick face	36
Figure 15 — Plan showing precast cladding detail around in situ concrete column	36

	Page
Figure 16 — Diagrammatic section of screeding	37
Figure 17 — Normal distribution of sizes	38
Figure 18 — Indication of a systematic deviation of + \bar{x} mm from a target size	39
Figure 19 — Distance between walls or columns	43
Figure 20 — Distance between floor and soffit in concrete structures	43
Figure 21 — External dimensions of buildings and ground floor slabs	44
Figure 22 — Level of floor and/or soffit of concrete slab	44
Figure 23 — Level of soffit of concrete beams	44
Figure 24 — Level of top of steel beams	45
Figure 25 — Verticality of walls and columns i.e. measurement procedure using a plumb-bob	45
Figure 26 — Depth of insitu concrete beams	46
Figure 27 — Size and squareness of concrete columns	46
Figure 28 — Straightness of walls in any 5 m length	46
Figure 29 — Height of brick or block walls	47
Figure 30 — Level of bed joints of brick or block walls	47
Figure 31 — Thickness of brick walls	47
Figure 32 — Window and other openings	48
Table 1 — Range of deviations normally achievable for construction	7
Table 2 — Range of deviations normally achievable for manufactured components	16
Table 3 — Accuracy in use of measuring instruments	30
Table 4 — Characteristic accuracy values for construction determined from a Building Research Establishment survey from 1975 to 1976	40
Table 5 — Characteristic accuracy values for manufactured components determined from BRE survey, 1988 to 1989	42
Publications referred to	Inside back cover

Foreword

This British Standard, having been prepared under the direction of the Basic Data and Performance Criteria for Civil Engineering and Building Structures Standards Committee, is a revision of BS 5606:1978 which is withdrawn.

Difficulty has been experienced in the application of the original 1978 code, entitled “Code of practice for accuracy in building”. Accordingly this revision of BS 5606 has been retitled, rewritten and reorganized.

Users are advised that the contents of this standard are not intended to be invoked in the form: “All tolerances to conform to BS 5606”.

A British Standard does not purport to include all the necessary provisions of a contract. Users of British Standards are responsible for their correct application.

Compliance with a British Standard does not of itself confer immunity from legal obligations.

Summary of pages

This document comprises a front cover, an inside front cover, pages i to iv, pages 1 to 48, an inside back cover and a back cover.

This standard has been updated (see copyright date) and may have had amendments incorporated. This will be indicated in the amendment table on the inside front cover.

0 Introduction

0.1 General

In any building or manufacturing process some degree of dimensional variability is inevitable. Disregarding errors, it has been shown (see Appendix C) that dimensional variability occurs even when properly trained operatives using the correct tools, procedures and materials make a genuine attempt to achieve the specified size. This variability arises because of the physical limitations of the operative and inherent variability of the tools, measuring equipment and materials used. The magnitude of this variability varies from process to process and is characteristic of the process. This guide deals with this variability induced by the building process.

Most buildings include some factory made components. Indeed some buildings use virtually no traditional materials and skills at all, comprising as they do steel frames with proprietary roofs, cladding, internal partitions and sophisticated mechanical and electrical services. In these circumstances consideration has to be given as to how the factory made components, each with its characteristic variability, will fit together with those elements constructed on the site.

0.2 Historical aspects

Early in this century buildings were much simpler than they are today and were constructed by traditional methods, using relatively few and traditionally well understood materials, by operatives using well developed and established skills. In these circumstances the bricklayer could adjust the brickwork to the sizes required, the carpenter was able to make the traditional roof fit the brickwork, the joiner could make the windows fit the holes left by the bricklayer, and the plasterer could overcome any irregularities in walls and ceilings.

In the post war years widespread use of in situ reinforced concrete frames clad with precast concrete units or proprietary cladding systems gave rise to many acute problems of fit. These problems, which caused delays to contracts and increased costs, resulted in a request for BSI to prepare guidance on this subject. This resulted in the publication in 1969 of PD 6440 "Accuracy in building" (now withdrawn).

A weakness of PD 6440 was that it was based on estimated values of accuracy rather than actual measured data. To overcome this weakness a survey of the variability of building processes was carried out by The Building Research Establishment (BRE) which was the basis for BS 5606:1978 Code of practice for accuracy in building.

0.3 Buildings Research Establishment survey

Previous guidance by BSI on the subject of accuracy in building was hampered by the absence of data on the variability of the various building processes. To overcome this problem BSI and the Department of Environment commissioned a survey of dimensional variability on projects where tolerances had been specified. The results of the survey were analysed by the Building Research Establishment and are included in Table 4. Additional dimensional data for manufactured components have been obtained more recently and are included in Table 5. The original survey did not cover all building processes and data collection is continuing. The survey established the important concept of characteristic accuracy (see C.3) from which the values of deviation ranges (Table 1 and Table 2) are derived.

0.4 Objective of the guide

The objective of this guide is to provide advice on ways to avoid problems of inaccuracy or fit arising on site. The need for such advice on any particular project will vary, depending on the character of the project and the materials and methods of construction. This guide is designed to be relevant to all building types including the most sophisticated ones. Those concerned with an individual project will judge the extent to which each section of this guide is relevant to their particular needs.

This guide is particularly applicable wherever components, made off site, are to be assembled on site with site constructed work, or where statutory maximum or minimum sizes are required.

Section 1. General

1 Scope

This British Standard guide explains and gives examples of principles that relate to accuracy in building construction.

It is intended to be applied to building rather than civil engineering works and aims to assist in the following:

- a) avoiding or resolving problems of inaccuracy or fit by assessing the dimensional needs of a design regarding tolerances, and then designing and specifying appropriately;
- b) assessing the likely achievement of tolerances specified for a particular project, and giving guidance on their realization;
- c) monitoring and controlling work during construction to ensure that it complies with specified accuracy.

Appendices give information relating to site surveys, examples of the calculation of tolerances, characteristic accuracy values, and data from the BRE survey (see the introduction).

NOTE The titles of the publications referred to in this standard are listed on the inside back cover.

2 Definitions

For the purposes of this guide the definitions given in BS 6100-1.5.1 apply together with the following:

2.1

characteristic accuracy

accuracy, expressed in terms of systematic deviation or standard deviation or both, found by measurement of a representative sample and assumed to be characteristic of the whole¹⁾

NOTE See also Appendix C.

2.2

induced deviation

inevitable departure from target size due to the building process

2.3

inherent deviation

inevitable departure from target size due to the physical properties of building materials and soils (see 8.4)

2.4

reference size

size specified in the design to which deviations are related

2.5

target size

reference size from which deviations would ideally be zero

2.6

tolerance

permissible variation of the specified value of a quantity

¹⁾ Taken from BS 6100-1.5.1.

Section 2. Problems of inaccuracy or fit associated with elements and components of construction

3 General

If the variability of all construction operations, whether carried out on site or in the factory, is recognized at the design stage, problems of inaccuracy or fit can be minimized and delays and expensive remedial measures can be avoided.

The primary aim should be to remove as many constraints on fit as possible and provide for adjustability of fixing so that fine adjustment of position can be made on site.

An example of these principles can be seen in the development of kitchen furniture. Early furniture for fitted kitchens was made in the traditional way with the doors set into the carcass using traditional simple hinges. This approach gave rise to problems on site with fit and alignment of doors. To overcome these problems the constraints on fit of doors have been removed by mounting them on the face of the carcass and adjustability of position has been achieved by the development of special hinges.

The examples given in clauses 4 and 5 illustrate some of the more common of these problems.

4 Examples of typical problems

4.1 Concrete floors

In deriving the levels for a structural floor it should be remembered that the specified minimum thickness of in situ flooring will be applied over the highest point of the structural floor. See Figure 1.

As types of flooring of differing thicknesses may occur in adjacent areas of the same floor, the finished floor level is normally taken as the datum.

The thickness specified should allow for deviations from the designed structural level, for deflection and for the effect of dead load on camber as well as for conduits, ducts, cross-overs and junction boxes.

The flatness of integral surface finishes depends on the method of construction.

Recommended tolerances in the surface finish of in situ floorings are given in BS 8204-1 for surfaces to receive a covering, and in BS 8204-2 for concrete wearing surfaces.

4.2 Roof deckings

The design of a roof should allow not only for manufacturing deviations in the decking but also for deviations in the overall sizes and shape of the roof, in positions of supports and in the sizes and positions of roof lights, etc. The designed fall should be calculated to allow for deviations in the level of the supporting members and deflection of the deck.

4.3 Stairs

Where the thicknesses of the finish to a stair and adjoining floors will differ, allowance should be made in the structural design of floors and staircases.

Problems of fit may arise if consideration is not given to the tolerances in the storey height, in the dimensions of the stair flight and in the stair well to receive the stair flight (see BS 5395).

4.4 Lift wells

The specification of lift well sizes should receive special consideration so that accurate construction may be achieved: see BS 5655-5 and BS 5655-6 in addition to the tolerances given in Table 1. See also Figure 2 for guidance regarding the specification of target sizes for lift wells.

In forming the structural openings in concrete walls to lift wells, allowance for masking or packing should be provided to enable doors to be aligned vertically with each other in elevation, by increasing the width and height of the openings, and by reducing the size by means of packings after the doors have been located correctly.

Since door openings might not line up one above another in section through the shaft, adjustments should be allowed for in the width of linings to jambs to mask inaccuracies.

As the height of the lift well increases, the difficulty in getting door openings to line up one above the other increases also; therefore in lift wells higher than 60 m, the width of structural openings to receive lift doors should be increased by an appropriate amount (see Table 1).

It is important to facilitate the alignment of landing sills; one way of doing this is by providing, at each landing, an independent threshold, the position of which can be adjusted.

4.5 Cladding to external walls

Cladding which presents unbroken vertical planes needs special care. Supporting nibs, brackets, ties and fixings have to allow not only for expected deviations in floor edges and columns at one level alone, but also for expected deviations over the whole building face.

Deviations to be taken into account should include those in transferring reference marks up the building, in transferring reference marks horizontally at any level, in setting out the building face from the reference marks, and in the verticality, alignment and position on plan of floor edges or columns at any level; the total effect should be assessed statistically.

Fixings should be provided with a range of adjustability at least equal to the total range of expected deviation so assessed; consideration should be given to the strength and security of fixings when they are at the limit of their adjustability.

When cladding such as curtain walling forms a continuous plane it is recommended that, in addition to the adjustability described above, fixings should provide an additional "stand off" clearance to safeguard against intrusion of floor edges into the cladding zone between fixings. See CP 143, CP 297 and BS 8298 for further recommendations on cladding.

It is common practice in framed buildings for external walls to be built as brick panels supported on the floors. In some cases in this form of construction the elevation will show as a continuous brick face concealing the frame, and in such cases the walls should oversail the edges of the floors. The use of brick slips to be fixed to and to hide the edges of the floors is deprecated, as inaccuracies of line at the edges and of the position on plan, of successive floors relative to one another are such that consistent satisfactory bearing for the oversailing brickwork is unlikely to be achieved.

4.6 Windows, doors and panelling units

When windows, doorsets or panels are to be fixed into pre-formed openings it is essential that the sizes for openings and components should be determined by consideration of fit. Reference should be made for suitable procedures to Appendix B and to Parts 1, 2 and 3 of BS 6954. See also Figure 3.

Openings can be formed with greater precision by the use of temporary frames or jigs. However, the size of the temporary frame should take account of the dimensional variability of the component to be fitted into the opening and the thickness of the joint between the component and surrounding material.

When windows, doorsets or cladding units are to be built in as the work proceeds, and the positions of the openings are important, critical dimensions should be identified and the tolerances should be specified.

Composite windows spanning floor to ceiling have to be accommodated within only two joints, and deviations in parallelism and squareness of the opening are critical.

4.7 Prefabricated partitions

When partitions are to be fitted between previously constructed items, problems of fit can arise. It should be ensured that the particular system can accommodate any tolerance in the floor and ceiling level and is capable of maintaining the performance requirements specified for a particular project in the project documentation, for example for sound attenuation, thermal insulation and fire resistance.

Any trim should be large enough to accommodate the predicted total of deviations in the structure and adjacent components and in the partition.

Particular attention should be given to make-up pieces and the trim needed to mask the joints.

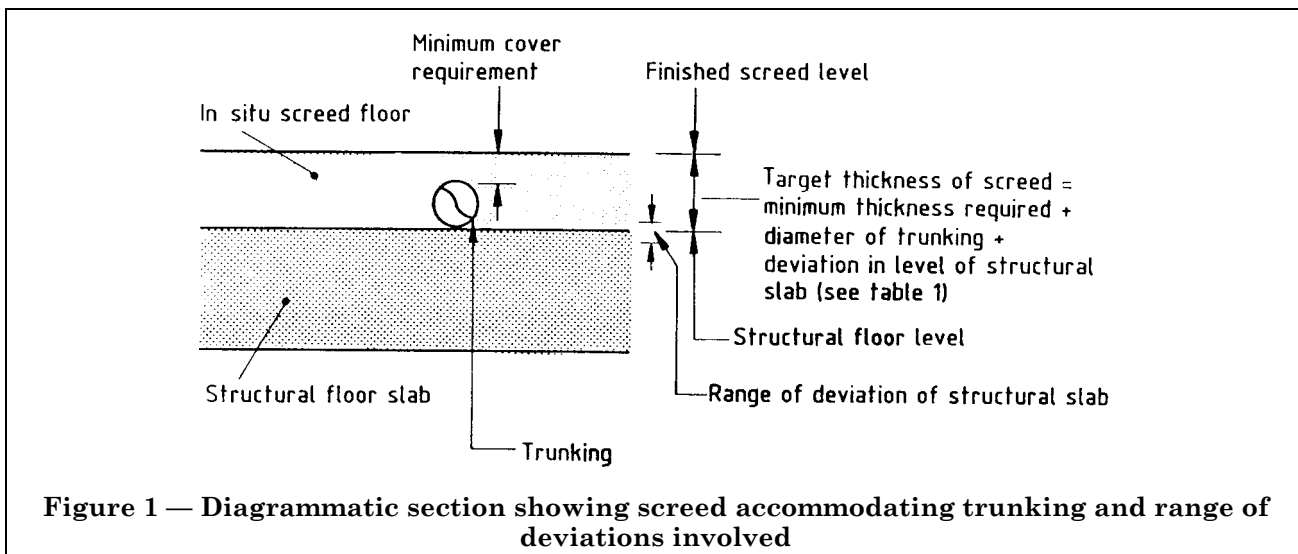

Figure 1 — Diagrammatic section showing screed accommodating trunking and range of deviations involved

Where partitions are to be fixed to pre-placed fixing blocks, allowance should be made for the size and position of the block so that the fixing device comes within the middle third of the block.

4.8 Pipework

It should be recognized that deviations will occur in the manufacture of pipework and conduit assemblies and in the location of inlets and outlets connected to the structure. The in situ connection should be designed to accommodate the predicted total of deviations from all sources.

4.9 Ductwork

It is recommended that sizes of apertures for ducting, including allowance for insulation, joints, flanges, junctions, cross-overs, valves and fixing lugs, should be shown on the drawings.

Consideration should be given to the order of installation and the space needed for access to install, operate and maintain equipment. When insulation is to be applied to the duct after installation, sleeves should be inserted at the point where the ducting passes through the structure.

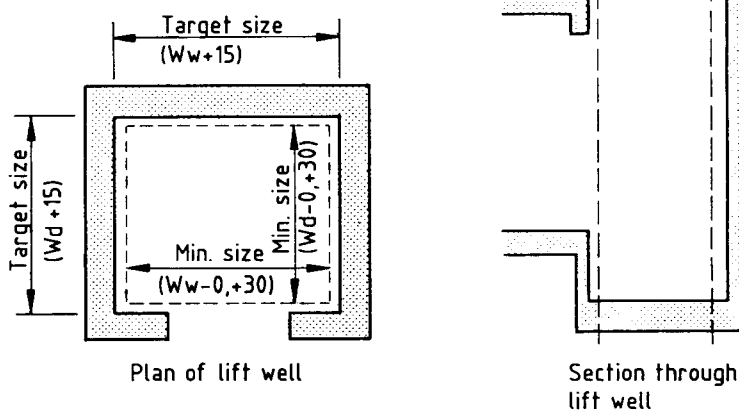

Ww: Lift manufacturer's minimum lift well width
Wd: Lift manufacturer's minimum lift well depth

NOTE Lift manufacturers sometimes specify the sizes of the lift well with the tolerance expressed in the form $-0 + 30$. Since actual sizes are, for practical purposes, distributed equally about the target size (see Appendix C) it follows in this instance that the target size for the length and width of the lift well will be minimum size + 15 with a tolerance of ± 15 .

Figure 2 — Target sizes of lift well

Tolerances specified for the sizes of the openings to be left should allow ventilating grilles or diffusers to be fitted and for flanges to mask the joints and/or packings.

4.10 Patterned finishes

If the finish consists of manufactured units, such as tiles which when applied form a pattern, consideration should be given to the manner in which the deviations in the structural frame and backing can be accommodated or masked.

Provision should be made in the layout of manufactured units, e.g. tiles, for deviation in manufacture and application; so that, for instance, whenever practicable joint lines coincide.

4.11 Furniture and fittings

When items are to be placed in position, or built in, account should be taken of the deviations in the dimensions of surfaces forming the recess or other position into which the items fit, and allowance should be made for manoeuvring the items into position.

4.12 Site information

In order that the location of each proposed building can be determined, accurate information should be provided regarding the location, dimensions and contours of the site, and regarding the position of any existing features and services that may affect or be affected by a new construction.

Recommendations concerning site surveys are given in Appendix A.

5 Designing out problems

Experience has shown that practical measures can be taken to avoid common problems. Examples of these measures are as follows.

- The visual effects of inaccuracies should be minimized, e.g. in a run of storey-height panels, each of which may vary in width within the stated tolerances, the position of each may be adjusted on site to achieve regular joint widths. Uneven joints will be far more noticeable than irregular panel sizes.
- The sizes of timber and structural steel sections are commonly described by nominal values that differ significantly from their work sizes. Design should be based on actual sizes.
- Fixings that have critical locations should have allowance made in the design and construction for dimensional adjustment.
- Fixings cast in situ or pockets for fixings, such as lift guides, should be avoided as far as possible by using fixings which do not require preformed holes.

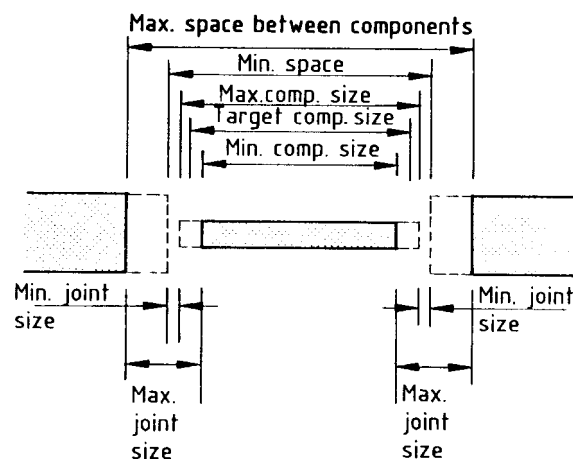

Figure 3 — Diagrammatic plan showing dimensional variabilities relating to component, prepared space and joint

Table 1 — Range of deviations normally achievable for construction (risk of non-compliance of approximately 1 in 22)
 [see Appendix C)]

Item of construction		Location	Construction material					
			Brickwork	Blockwork	In situ concrete	Precast concrete	Steel	Timber
			mm	mm	mm	mm	mm	mm
T.1.1 space ^a between elements	Walls up to 7 m apart	At floor	± 15	± 16	± 24	± 15	NA	± 27
		At soffit	± 20	± 21	± 24	± 18	NA	± 32
	Columns up to 7 m apart	At floor	NA	NA	± 17	± 13	± 12	± 12 ^b
		At soffit	NA	NA	± 18	± 13	± 10	—
Cased steel columns	At floor	NA	NA	NA	NA	± 16	NA	
	At soffit	NA	NA	NA	NA	± 16	NA	
Beams and floor slabs	Floor to soffit height		NA	NA	± 23	± 19	—	—
T.1.2 openings	Window or door	Width up to 3 m (not jigged)	± 20	—	± 14	± 11	—	—
		Height up to 3 m (not jigged)	± 20	—	± 20	± 10	—	—

Table 1 — Range of deviations normally achievable for construction (risk of non-compliance of approximately 1 in 22)
[see Appendix C)]

Item of construction	Location	Construction material						
		Brickwork	Blockwork	In situ concrete	Precast concrete	Steel	Timber	
		mm	mm	mm	mm	mm	mm	
T.1.3 Size and shape of elements and components	Walls	Height up to 3 m	± 26	± 28	—	—	NA	—
		Thickness	± 20	± 19 ^b	± 8 ^b	—	NA	—
		Straightness in 5 m	± 5	± 6	± 9	± 6	NA	—
		Abrupt changes in a continuous surface	—	—	± 4 ^b	± 3 ^b	NA	NA
		Verticality up to 2 m	9	9	11	8	NA	14
		up to 3 m	10	10 ^b	17	11	NA	—
		up to 7 m	14 ^b	14	16 ^b	14 ^b	NA	NA
	Level of bed joints	± 11	± 13	NA	NA	NA	NA	
	columns	Size on plan up to 1 m	—	—	± 8	—	—	—
		Verticality up to 3 m	NA	NA	12	10	6	10
		up to 7 m	NA	NA	16 ^b	14 ^b	8	—
		Cased steel verticality up to 3 m	NA	NA	NA	NA	10	NA
	Beams	Squareness	NA	NA	9	—	—	—
		Depth (Perimeter beams) up to 600 mm	NA	NA	± 13	—	—	—
			over 600 mm	NA	NA	± 20	—	—
		(Internal beams) up to 600 mm over 600 mm	NA	NA	± 12	—	—	—
			NA	NA	± 16	—	—	—
		Level ^c	NA	NA	± 22	± 23	± 20	± 20 ^b
Variation from target plane	NA	NA	10 ^b	8 ^b	8 ^b	10 ^b		
Straightness in 6 m	NA	NA						

Table 1 — Range of deviations normally achievable for construction (risk of non-compliance of approximately 1 in 22)
 [see Appendix C)]

Item of construction		Location	Construction material					
			Brickwork	Blockwork	In situ concrete	Precast concrete	Steel	Timber
			mm	mm	mm	mm	mm	mm
T.1.3 Size and shape of elements and components <i>(continued)</i>	Suspended structural floor before laying of screed ^e	Level ^d						
		Variation from target plane in situ or precast slab	NA	NA	± 25	± 28	NA	—
		Variation from target plane in situ topping on precast	NA	NA	NA	± 31	NA	NA
		Structural soffit	NA	NA	± 19	± 18	NA	—
	Non suspended floor slabs before laying of screed ^f	Thickness	NA	NA	± 10 ^b	—	NA	NA
		Level ^d						
		Variation from target plane	NA	NA	± 25 ^b	—	NA	NA
	In situ floorings	Surface regularity ^d						
		Direct finished base slabs, topping and screeds						
Variation from target plane		NA	NA	± 15 ^b	—	NA	NA	
Flatness		NA	NA	± 5 ^b	—	—	—	
	Abrupt change across joints	—	—	± 2 ^b	—	—	—	

Table 1 — Range of deviations normally achievable for construction (risk of non-compliance of approximately 1 in 22)
[see Appendix C)]

Item of construction		Location	Construction material					
			Brickwork	Blockwork	In situ concrete	Precast concrete	Steel	Timber
			mm	mm	mm	mm	mm	mm
T.1.4 Overall size on plan	Building	Length or width up to 40 m	± 29	—	± 26	± 38	± 14	—
	Ground floor slab	Length or width	NA	NA	± 28	—	NA	NA
T.1.5 Position on plan in relation to the nearest reference line at the same level								
a) Foundations								
Mass concrete in excavated ground with minimum formwork Reinforced concrete including rafts, ground beams, column bases, pile caps and strip footings			NA NA	NA NA	± 50 ^b ± 50 ^b	NA ± 20 ^b	NA NA	— —
b) Walls			± 10 ^b	± 10 ^b	± 16 ^b	± 14 ^b	± 10 ^b	± 14 ^b
c) Structural frame-columns			± 10 ^b	NA	± 12 ^b	± 10 ^b	± 10 ^b	± 10 ^b
d) Lift walls			± 10 ^b	± 10 ^b	± 12 ^b	± 10 ^b	NA	NA
e) Stair wells			± 10 ^b	± 10 ^b	± 12 ^b	± 10 ^b	NA	NA
f) Finished stairs (flight from landing to landing)			NA	NA	± 12 ^b	± 10 ^b	NA	NA
g) Door, window and other openings			± 10 ^b	± 10 ^b	± 12 ^b	± 10 ^b	NA	± 10 ^b
h) Formers for items to be cast or built in			± 6 ^b	± 6 ^b	± 6 ^b	± 6 ^b	NA	NA
i) All other elements above foundations			± 10 ^b	± 10 ^b	± 12 ^b	± 10 ^b	± 10 ^b	± 10 ^b

Table 1 — Range of deviations normally achievable for construction (risk of non-compliance of approximately 1 in 22)
[see Appendix C)]

Item of construction	Location	Construction material					
		Brickwork	Blockwork	In situ concrete	Precast concrete	Steel	Timber
		mm	mm	mm	mm	mm	mm
T.1.6 Dimensions on plan in relation to target sizes							
a) Foundations:							
Mass concrete [as T.1.5(a)]		NA	NA	± 50 ^b	NA	NA	NA
Reinforced concrete [as T.1.5(a)]		NA	NA	± 50 ^b	± 10 ^b	NA	NA
b) Structural frame length and width up to 8 m							
Over 8 m and up to 15 m		± 12 ^b	± 12 ^b	± 16 ^b	± 12 ^b	± 12 ^b	± 12 ^b
Over 15 m and up to 25 m		± 16 ^b	± 16 ^b	± 18 ^b	± 16 ^b	± 16 ^b	± 16 ^b
c) Stairs (structural) ^g							
Length of clear span		NA	NA	± 14 ^b	± 12 ^b	± 12 ^b	± 12 ^b
Width of flight		NA	NA	± 8 ^b	± 6 ^b	± 6 ^b	± 8 ^b
Difference in width of tread or going of consecutive steps		NA	NA	± 10 ^b	± 8 ^b	± 8 ^b	± 10 ^b
Waist thickness measured square to slope of flight		NA	NA	± 8 ^b	± 6 ^b	± 6 ^b	± 8 ^b
Stairs (finished) ^g							
Length of clear span		NA	NA	± 12 ^b	± 10 ^b	± 10 ^b	± 12 ^b
Width of flight		NA	NA	± 10 ^b	± 10 ^b	± 10 ^b	± 10 ^b
T.1.7 Position in elevation in relation to the nearest reference line							
a) Door, window and other openings including lift landing doors							
		± 15 ^b	± 15 ^b	± 15 ^b	± 15 ^b	NA	—
b) Timber components							
		NA	NA	NA	NA	NA	± 10 ^b
c) Formers for items to be cast or built in							
		± 10 ^b	± 10 ^b	± 10 ^b	± 10 ^b	NA	NA

Table 1 — Range of deviations normally achievable for construction (risk of non-compliance of approximately 1 in 22)
[see Appendix C)]

Item of construction	Location	Construction material					
		Brickwork	Blockwork	In situ concrete	Precast concrete	Steel	Timber
		mm	mm	mm	mm	mm	mm
T.1.8 Levels. Range of deviations in level with reference to the nearest T.B.M.							
a) Foundations							
Mass concrete [as T.1.5.(a)]							
Formation surface of excavation or blinding concrete		NA	NA	± 34 ^b	—	NA	NA
Upper surface		NA	NA	20 ^b	—	NA	NA
Reinforced concrete [as T.1.5.(a)]							
Formation surface of excavation or blinding concrete		NA	NA	± 30 ^b	—	NA	NA
Upper surface		NA	NA	± 16 ^b	—	NA	NA
b) Concrete frame							
Structural roof							
Upper surface height up to 30 m		NA	NA	± 16 ^b	± 20 ^b	NA	NA
For each subsequent 30 m				± 8 ^b	± 10 ^b	NA	NA
c) Steel/timber structural frame							
Base of first erected or constructed member		NA	NA	NA	NA	± 10 ^b	± 12 ^b
Top of the steel frame at any storey		NA	NA	NA	NA	± 16 ^b	± 20 ^b
Difference in level in any 5 m length measured at that storey		NA	NA	NA	NA	± 6 ^b	± 10 ^b
d) Stairs (Structural)							
Vertical height of any flight between landings		NA	NA	± 15 ^b	± 15 ^b	—	—
Difference in rise of any consecutive steps		NA	NA	± 6 ^b	± 4 ^b	—	—
Difference in level of tread with the going		NA	NA	± 4 ^b	± 4 ^b	—	—
Per metre width of stair (other widths pro rata with a maximum of 10 mm)				± 5 ^b	± 5 ^b		
Stairs finished vertical height of any flight between landings		NA	NA	± 10 ^b	± 10 ^b	± 10 ^b	± 10 ^b
e) Door, window and other openings including lift landing doors							
Sill and soffit, for each 1 m of width (other widths pro rata with a maximum of 15 mm)		± 6 ^b	± 6 ^b	± 6 ^b	± 6 ^b	—	—

Table 1 — Range of deviations normally achievable for construction (risk of non-compliance of approximately 1 in 22)
[see Appendix C)]

Item of construction	Location	Construction material					
		Brickwork	Blockwork	In situ concrete	Precast concrete	Steel	Timber
		mm	mm	mm	mm	mm	mm
T.1.9 Verticality at any point							
a) Lift wells							
Each wall							
For the first 30 m of height							
For each additional 12 m of height with a maximum of ± 65 mm							
		26 ^b	26 ^b	25 ^b	26 ^b	NA	NA
		6 ^b	6 ^b	6 ^b	6 ^b	NA	NA
b) Door jambs							
Plumbness							
For each metre of height with a maximum of 15 mm							
		4 ^b	4 ^b	4 ^b	4 ^b	NA	NA
c) Timber components							
In any 3 m of height							
		NA	NA	NA	NA	NA	8 ^b
<p>NOTE The values in Table 1 are based on the characteristic accuracy values given in Table 4 and have been obtained by multiplying the measured standard deviations by 2 and adding the value of the measured systematic deviation (disregarding its sign) and rounding to the nearest 1 mm.</p> <p>^a Values for space between elements take into account variabilities due to position, verticality, straightness/bow and cross section, and should not be combined with values for the latter items.</p> <p>^b Estimated value.</p> <p>^c Level variability of beams is measured on the soffit of concrete beams but on the top of steel beams.</p> <p>^d Variability of surface level can be expressed in two ways.</p> <p> a) Variation from target plane i.e. Variability above and below the target plane, (defined with reference to an adjacent TBM) of each of the points levelled.</p> <p> b) Flatness, i.e. “Flatness” of the surface, is defined as the departure from a 3 m straightedge in contact with the floor. This value of flatness is already taken into account in a) above and therefore should not be combined with variation in datum.</p> <p>^e A suspended structural floor is one designed to span between edge supports.</p> <p>^f Range of deviations given apply to offices, residential buildings and ordinary industrial ground bearing slabs. Modern high density warehouses with sophisticated and semi-automated stacking using narrow aisle trucks need higher standards of surface regularity of the floors. Concrete Society Technical Report no. 34 “Concrete Industrial Ground Floors” provides valuable guidance on this subject.</p> <p>^g Check building regulations.</p> <p>NA = not applicable.</p> <p>— = data not available.</p>							

Section 3. Designing to achieve good fit and assembly

6 General

In any production process dimensional deviations are inevitable. Hence the size and shape of buildings or building components will seldom, if ever, equal exactly those specified or shown on the drawings.

Inadequate provision in the detail design of tolerances appropriate to the building being designed can create construction and assembly difficulties. These difficulties often lead to unsatisfactory performance and appearance of the building, which can be difficult and expensive to overcome.

Taking a realistic view of the dimensional variability in manufacture and construction will assist the process of arriving at appropriate details that can be achieved in practice and that avoid details with unnecessary tolerance constraints.

7 Tolerances

7.1 Aims

Tolerances should be considered at the outset of each project so that:

- the practicality of the design details in relation to fit can be assessed;
- the appropriate tolerances, reflecting the needs of the design, can be specified;
- compliance with tolerances during construction and assembly can be monitored.

7.2 Factors affecting tolerances

Tolerances should take account of the following:

- the character and appearance of the building;
- the dimensional requirements imposed by regulation or statute;
- the nature of the proposed construction (traditional or skeletal frame, type of cladding, type of fenestration, building services etc.);
- type of details likely to be needed for the proposed construction (façade treatment, jointing systems, waterproofing, finishes etc.);
- method of construction (e.g. traditional, high tech, in situ, precast);
- induced deviations associated with items of construction, components and setting out;
- inherent deviations.

7.3 Procedure for specifying tolerances

The procedure recommended for specifying tolerances is as follows:

- identify areas where dimensions are likely to be critical for the satisfactory performance of the design;

- choose design details that avoid problems of fit and minimize the number of tolerance constraints;

- select reasonable and achievable tolerance targets based upon normal methods and current practice, when it is not possible to avoid tolerance problems by design (see clauses 8 and 9);

- verify available methods, materials and techniques for special requirements of fit and assembly;

- make provision in joints to accommodate the build-up of individual dimensional variabilities;

- discuss the tolerance requirements with each participant in a project as soon as feasible to ensure understanding of the design intentions, development of building details and a positive commitment to achieving fit.

8 Basic information and analysis of dimensional variability

8.1 Range of deviations associated with items of construction

Table 1 gives values of a range of deviations for a number of items of construction and materials. These values are for normal methods of working; namely, the use of conventional construction techniques, the use of conventional materials, current standards of workmanship and usual site conditions. The values include the contributions of all the constituent variabilities in for example bow, twist, verticality, camber etc., and are based on the characteristic accuracy values given in Table 4 in Appendix C.

NOTE The values in Table 1 are based on two standard deviations and on the systematic deviation for each process.

For those items of construction which were not part of the BRE measurement survey (see Appendix C and Appendix D) an estimated deviation is given in Table 1.

The risk that the range of deviations in Table 1 will be exceeded is small; approximately 1 in 22, i.e. the standard deviation (SD) is 2 SD, providing good building practice is followed.

Some diagrammatic examples of the range of deviations from Table 1 are given in Figure 4.

8.2 Range of deviations associated with manufactured components

Table 2 gives values of a range of deviations for a number of manufactured components and materials commonly used in building construction. The values assume normal manufacturing techniques, the use of conventional materials of the required quality, current standards of workmanship and the appropriate level of dimensional quality control.

NOTE Because of the higher precision and tighter dimensional control in manufacturing processes, the values in Table 2 are based on 2 σ standard deviations and the systematic deviation for each process.

For those types of dimension which were not part of the measurement survey an estimated value is given. If no value is given, the information may be obtained from the relevant product/material British Standard. Dimensional accuracy information given in product material British Standards is generally described in terms of permissible (permitted) deviations.

Licensed Copy: Giorgio Cavalleri, none, 15-Nov-00, Uncontrolled Copy. © BSI

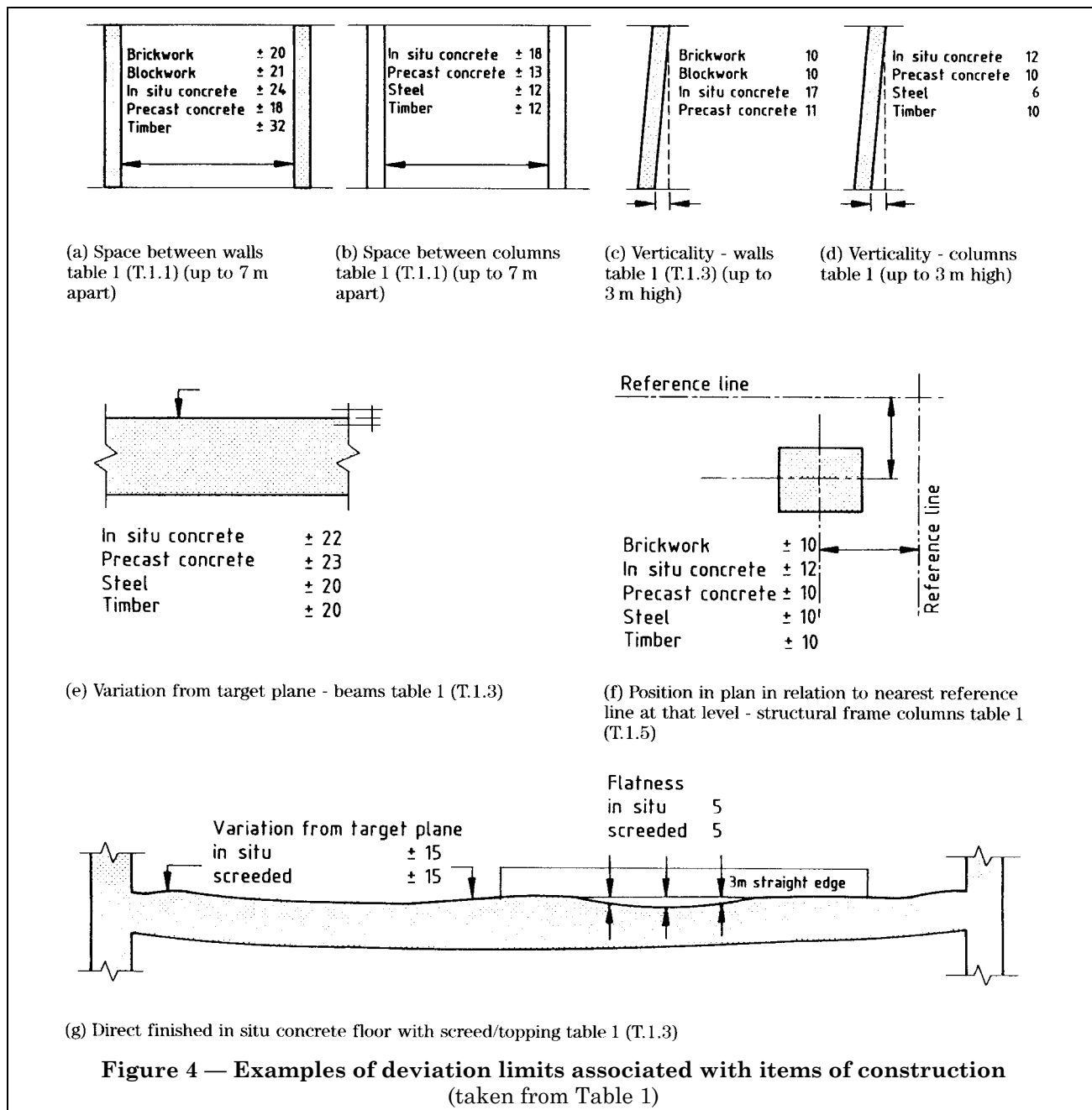

The risk that the range of deviations in Table 2 will be exceeded is very small; approximately 1 in 80 (i.e. $2\frac{1}{2}$ SD), providing good manufacturing practice is followed.

Some diagrammatic examples of the range of deviations from Table 2 are given in Figure 5.

8.3 Range of deviations associated with setting out

Setting out can involve making linear measurements, angular measurements, controlling verticality and establishing and transferring horizontal levels. For each of these tasks the accuracy achieved depends both on the measuring instruments and ancillary equipment used, as well as on the knowledge, skill and conscientiousness of the operator. Frequently there is a choice of a range of measuring instruments each of which can be used for the particular task with differing accuracy. The instrument chosen should be that which will give the required level of accuracy provided that a reasonable standard of skill is employed.

Table 2 — Range of deviations normally achievable for manufactured components (risk of non-compliance of approximately 1 in 80 [see Appendix C])

Item	Type of dimension measured	Construction material					
		Precast reinforced concrete	Precast prestressed concrete			Fabricated steel	Timber
			Stop end plated	Formed or extruded	Inverted T-beams		
T.2.1 Overall size [see Figure 5(a)]	Length up to 2 m	mm	mm	mm	mm	mm	mm
	2 m to 6 m	± 6	± 6	} ± 18	} ± 15	} ± 5	Length up to 6 m: Frames ± 4 Panels ± 5 Doors ± 3
	6 m to 10 m	± 9	± 9				
	10 m to 20 m	± 12	± 12	—	± 25		
	20 m to 30 m	—	—	—	± 35		
Length up to 12 m Height to apex	—	—	—	—	—		
Width or height up to 250 mm 250 mm to 1.25 m 1.25 m to 4.0 m	± 4	± 8	± 8	± 8	—	} Frames ± 4 Panels ± 4 Doors ± 3	
	± 6	± 8	± 8	± 12	—		
	± 8	± 14	—	± 16	—		
Thickness or depth up to 0.5 m 0.5 m to 1.5 m	± 6	± 7	± 10	± 6	—	—	
	± 8	—	—	± 6	—	—	
T.2.2 Shape [see Figure 5(b)]	Position and size of cut outs and extensions up to 0.5 m	± 6	—	± 17	± 17	—	—
	0.5 m to 10 m	± 12	—	—	± 17	—	—
	Squareness up to 1.2 m	± 6	—	—	12	—	—
	1.2 m to 1.8 m	± 9 ^a	—	—	—	—	—
	over 1.8 m	± 12 ^a	—	—	—	—	—
Flatness	6 ^a over a 1.5 m length	—	—	—	—	—	—
Position of internal holes up to 10 m	± 15	± 15	—	± 15	—	Frames and panels ± 5	

Table 2 — Range of deviations normally achievable for manufactured components [risk of non-compliance of approximately 1 in 80 [see Appendix C)]

Item	Type of dimension measured	Construction material					
		Precast reinforced concrete	Precast prestressed concrete			Fabricated steel	Timber
			Stop end plated	Formed or extruded	Inverted T-beams		
T.2.3 Connections [see Figure 5(c)]	Position of fixing plates or cleats up to 2 m 2 m to 10 m	mm	mm	mm	mm	mm	mm
		± 6 ± 14	± 9 ± 18	— —	± 9 ± 18	± 5 ± 5	— —
	Position of centres of bolt holes a) along length across width within cluster	± 9	± 11	—	± 11	± 5	—
		± 9 $\pm 3^a$	± 11 ± 3	— —	± 11 $\pm 3^a$	± 3 ± 2	— —
b) in welded end plates within cluster	—	—	—	—	± 4	—	
	—	—	—	—	± 2	—	
c) in base plates in relation to holes	—	—	—	—	± 4	—	
	—	—	—	—	± 4	—	

NOTE The values in Table 2 are based on the characteristic accuracy values given in Table 5, and have been obtained by multiplying the measured standard deviations by 2.5 and adding the value of the measured systematic deviation (disregarding its sign) and rounding to the nearest 1 mm.

^a Estimated value.

Table 3 (in Appendix A) indicates the range of deviations which may occur and which rarely will be exceeded for each of the setting out tasks and for any of the types of measuring instruments in common use on building sites, provided that good practice is followed and reasonable care is exercised. The accuracy of the instruments should be checked periodically in accordance with BS 7334.

The ranges of deviations given in Table 3 are maximum practical ranges for each instrument. Reference may also be made to BS 5964.

Once the reference lines, points and levels have been set out within the building and have been checked to ensure that the achieved accuracy meets the range of deviations given in Table 3, the reference lines, points and levels establish the framework from which all other measurements will be made.

Thus the position of any element, component or part of the building will in practice be measured from these reference lines, points and levels.

Where it is necessary to consider combined deviations, the range of deviations given in Table 3 should be taken into account in addition to those given in Table 1 and Table 2. See the worked examples in Appendix B.

8.4 Inherent deviations

Inherent deviations result from the physical properties of the materials used and include thermal movements, moisture movements, elastic deformation due to both dead and applied loads e.g. deflection, creep.

These inherent deviations may be reversible or irreversible and appropriate provision has to be made for these movements when they are significant. The provision for these movements will depend on the design concepts, joint details, materials for construction involved and their predicted behaviour.

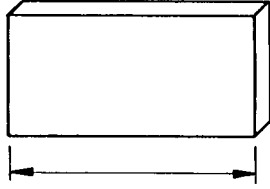

(1) length [Table 2 (T.2.1)]

Length measured	Precast reinforced concrete	Precast prestressed concrete			Fabricated steel	Timber all lengths
		Stop end plated	Formed or extruded	Inverted T-beams		
m	mm	mm	mm	mm	mm	mm
up to 2	± 6	± 6	—	—	—	—
2 to 6	± 9	± 9	—	—	—	—
6 to 10	± 12	± 12	—	—	—	—
up to 10	—	—	± 18	± 15	—	—
10 to 20	—	—	—	± 25	—	—
20 to 30	—	—	—	± 35	—	—
All lengths	—	—	—	—	± 5	Frames ± 4 Panels ± 5 Doors ± 3

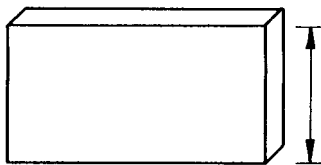

(2) width or height [Table 2 (T.2.1)]

Width or height measured	Precast reinforced concrete	Precast prestressed concrete			Fabricated steel	Timber all lengths
		Stop end plated	Formed or extruded	Inverted T-beams		
m	mm	mm	mm	mm	mm	mm
up to 0.25	± 4	—	—	± 8	—	—
0.25 to 1.25	± 6	—	—	± 12	—	—
up to 1.25	—	± 8	—	—	—	—
1.25 to 4.00	± 8	± 14	—	± 16	—	—
All widths	—	—	± 8	—	—	Frames ± 4 Panels ± 4 Doors ± 3

(a) Overall size

Figure 5 — Examples of deviations associated with manufactured components
(taken from Table 2)

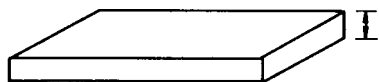

(3) thickness or depth [Table 2 (T.2.1)]

Thickness or depth measured	Precast reinforced concrete	Precast prestressed concrete			Fabricated steel	Timber all lengths
		Stop end plated	Formed or extruded	Inverted T-beams		
m	mm	mm	mm	mm	mm	mm
up to 0.50	± 6	± 7	± 10	± 6	—	—
0.50 to 1.5	± 8	± 7	± 10	± 6	—	—

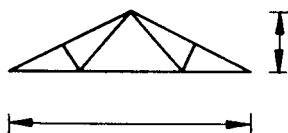

(4) length and height to apex
Timber roof trusses

Type of dimension measured	Deviation
Length	mm
Height to apex	± 15
	± 6

(a) Overall size

Figure 5 — Examples of deviations associated with manufactured components
(taken from Table 2)



(1) position and size of cut outs and extensions [Table 2 (T.2.2)]

Cut outs measured	Precast reinforced concrete	Precast prestressed concrete		
		Stop end plated	Formed or extruded	Inverted T-beams
m	mm	mm	mm	mm
Up to 0.50	± 6	—	± 17	± 17
0.50 to 10	± 12	—	± 17	± 17

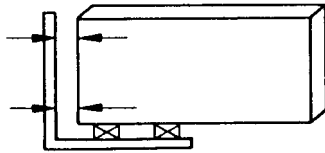

(2) squareness [Table 2 (T.2.2)]

Type of dimension measured	Deviation	
	Precast reinforced concrete	Precast prestressed concrete
Squareness	± 6 mm	± 12 mm

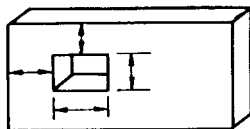

(3) internal holes [Table 2 T.2.2)]

Type of dimension measured	Precast reinforced concrete	Precast prestressed concrete	Timber frames and panels
Internal holes	± 15 mm	± 15 mm	mm Door ± 5 Windows ± 5

(b) shape

Figure 5 — Examples of deviations associated with manufactured components
(taken from Table 2)

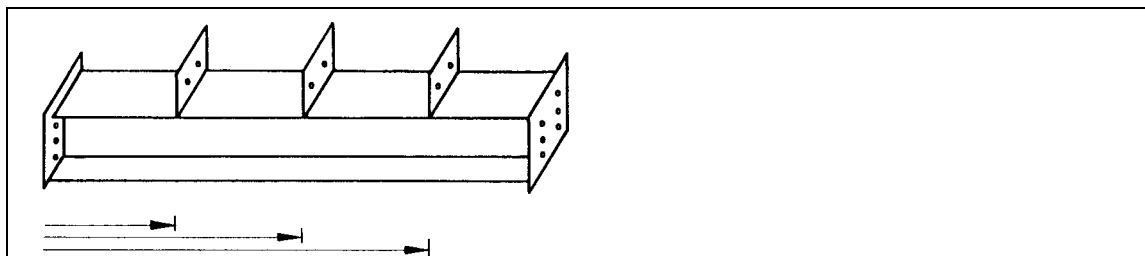

(1) position of cleats or fixing plates [Table 2 (T.2.3)]

Position of cleats or fixing plates measured	Precast reinforced concrete	Precast prestressed concrete	Fabricated steel
m	mm	mm	mm
Up to 2	± 6	± 9	± 5
2 to 10	± 14	± 18	± 5

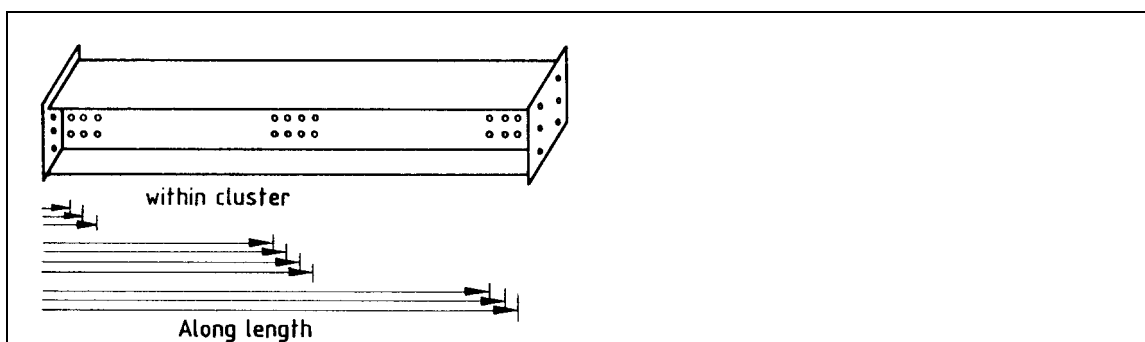

(2) position of centres of bolt holes [Table 2 (T.2.3)]

Type of dimension measured	Precast reinforced concrete	Precast prestressed concrete	Fabricated steel
	mm	mm	mm
Along length	± 9	± 11	± 5
Across width	± 9	± 11	± 3
Within cluster of holes	± 3	± 3	± 2

(c) Connections

Figure 5 — Examples of deviations associated with manufactured components
(taken from Table 2)

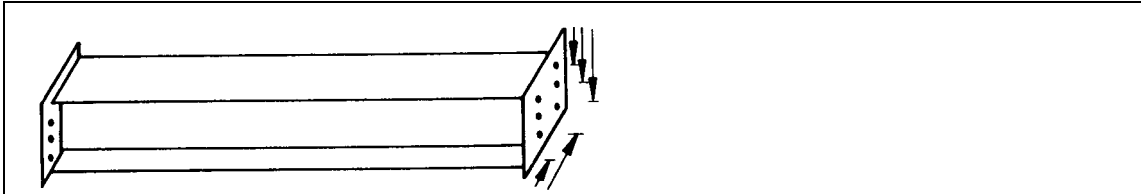

(3) position of centres of bolt holes within welded end plates [Table 2 (T.2.3)]

Type of dimension measured	Fabricated steel
	mm
Along length	± 4
Across width	± 4
Within cluster of holes	± 2

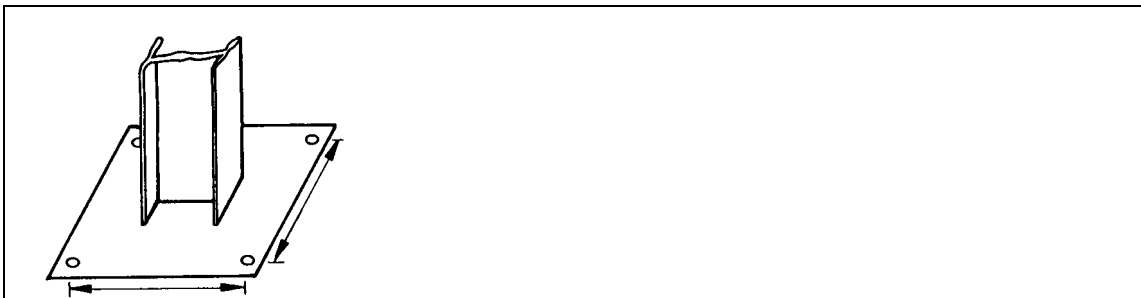

(4) position of centres of bolt holes [Table 2 (T.2.3)]

Type of dimension measured	Fabricated steel
	mm
In relation to other holes	± 4

(c) Connections

Figure 5 — Examples of deviations associated with manufactured components
(taken from Table 2)

9 Assessing the dimensional needs of a design

9.1 General

The dimensional accuracy appropriate to the particular needs of a given design can vary considerably, as follows.

- a) In some cases, for example where the type of structure is straightforward to construct, the required accuracy may be determined simply by direct reference to the ranges of deviations given in Table 1 and Table 2.
- b) In other cases it will be necessary to assess the combined effects of the variability of separate elements of construction or components that go into making up the detail. Some examples of the calculation tolerances are given in Appendix B.

c) In sophisticated structures it is important to resolve all problems concerning tolerances in advance. This may entail the construction of a full scale mock up to prove the design and make reasonable provision for variability at critical interfaces. The cost of this exercise should be balanced against the cost of the consequences of lack of fit and/or delay.

When maximum or minimum sizes are required, e.g. to comply with statutory requirements, the target size should be set so that when the tolerance is taken into account, the actual size will not be larger than the maximum size permitted or smaller than the minimum size permitted.

The steps recommended in 9.2, 9.3, 9.4 and 9.5 should be followed to make appropriate provision for dimensional variability for a particular design.

9.2 Step 1: Consideration of the dimensional variability of primary elements of construction

Table 1 gives the dimensional variability of site construction (see also 8.1). Figure 4 shows examples of the range of deviations given in Table 1. From this table an assessment can be made of the necessary allowances, and provision can be made in the design details to accommodate components; for example brick cladding around frame, or factory made components which have to be fitted within a structure constructed or erected on site.

9.3 Step 2: Consideration of the dimensional variability of components

Table 2 gives the dimensional variability of manufactured components (see also 8.2). Figure 5 shows some examples of the range of deviations given in Table 2. Other information not covered in this table can be obtained from specialist manufacturers. Manufactured items are likely to possess a higher order of accuracy than those constructed on site, but nevertheless their variability needs to be provided for in the final assessment of combined fit.

9.4 Step 3: Assessment of combined deviation limits

When individual deviations, DL , DL_2 etc. for separate elements or components, (for which ranges of deviations are recorded in Table 1 or Table 2, or obtained from other sources), combine to influence a total deviation for a particular design detail, joint or interface, the corresponding total deviation DL_t can be found by:

- a) obtaining the corresponding separate deviation DL_1 , DL_2 etc., from Table 1 or Table 2 or other sources; and
- b) obtaining the total deviation DL_t by finding the square root of the sum of the squares of each individual deviation thus:

$$DL_t = \sqrt{\{(DL_1)^2 + (DL_2)^2 + (DL_3)^2 \dots\}}$$

Examples and guidance for calculation are given in Appendix B, and are illustrated in Figure 1, Figure 2, Figure 3, Figure 6 and Figure 7, for some common design situations for which the achievement of fit may be critical. In addition reference can be made to BS 6954-3 for full procedures relating target sizes and joint clearances. Such calculations should be carried out as relevant to any particular design.

The above equation applies to induced deviations.

Inherent deviations (as a result of changes in temperature, moisture content, deflection etc.) should be added arithmetically, to the total deviation (DL_t) obtained as noted in (b) above.

9.5 Finalization of design proposals

Checks should be made to ensure that the individual and combined deviations established in steps 1, 2 and 3 meet the needs of the design and construction. Reference should be made to 7.1 to ensure that the overall aims have been effectively satisfied. Particular attention should be given to the following:

- a) *Design of joints and connections.* The joint is the medium where the variabilities due to both induced and inherent deviations can be absorbed. Guidance on the selection of jointing methods is given in BS 6093 for structures, claddings, openings in walls, roofs, floors and services passing through building elements.
- b) *Detail drawings.* Detail drawings should be prepared for each type of joint or connection to a larger scale to indicate the interrelation of all parts of the connection. The detail drawings should allow for the effect of individual or combined deviations as calculated in 9.4.
- c) *Adjustability.* Adjustability should be provided in the details, for accommodating the tolerances for manufactured components/units (precast cladding, curtain walling, precast construction etc.) to the range of deviations applicable to site construction (Table 1).

Levelling bolts, bracket systems and careful detailing allow both vertical and elevational variabilities to be absorbed and eliminate conflict between the coarser site constructed tolerances and the finer manufactured tolerances.

- d) *Mock-ups and trials.* The construction of "mock-ups" or trials of the proposed construction and details should be considered to ensure that satisfactory fit can be achieved.

This consideration is of particular value in complex and sophisticated construction, or where the assembly programme for the project is critical, or where the tolerances required by the nature of the design are particularly demanding.

Explicit consideration, at the design stage, of details to absorb the dimensional variabilities of building components, materials and processes should permit the development and production of design details which will consistently perform satisfactorily.

²⁾ e.g. $(DL_3)^2$... etc ...

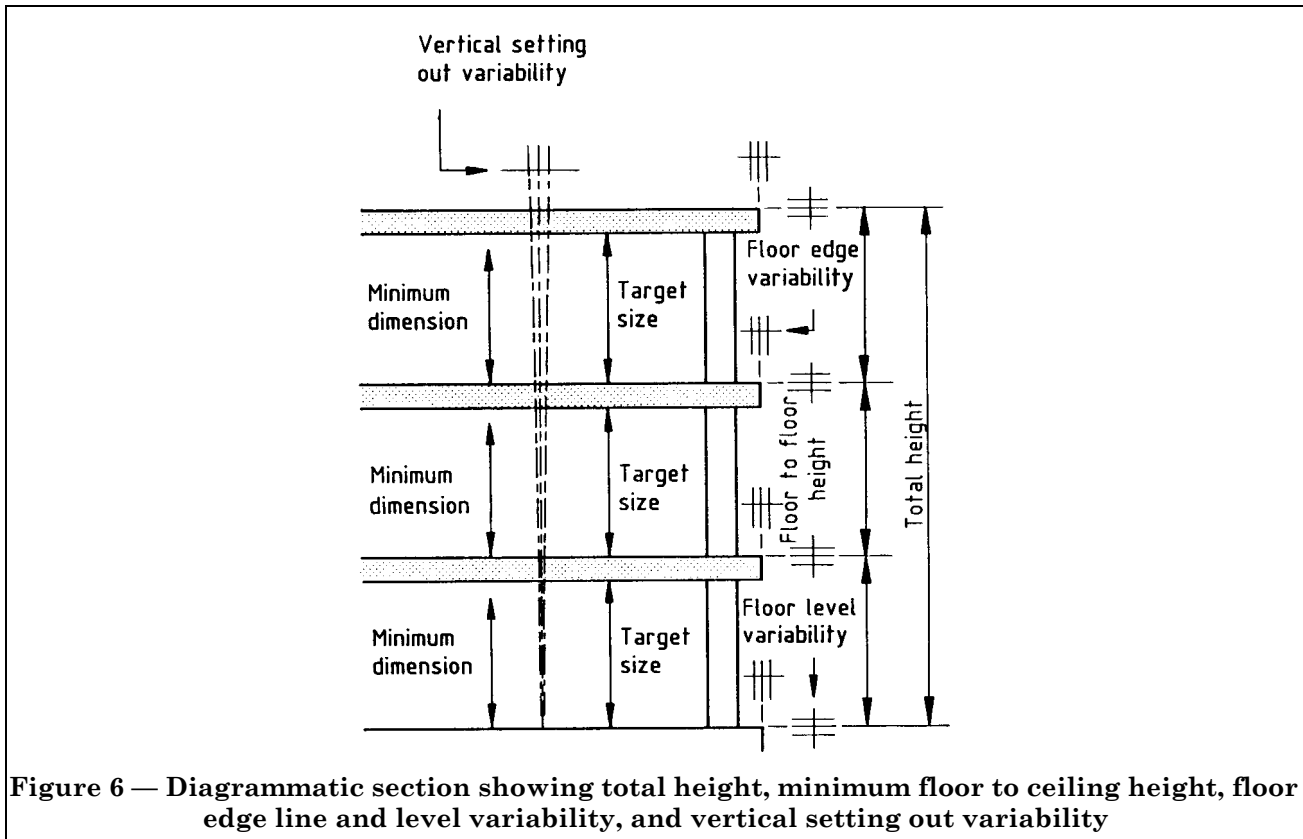

Figure 6 — Diagrammatic section showing total height, minimum floor to ceiling height, floor edge line and level variability, and vertical setting out variability

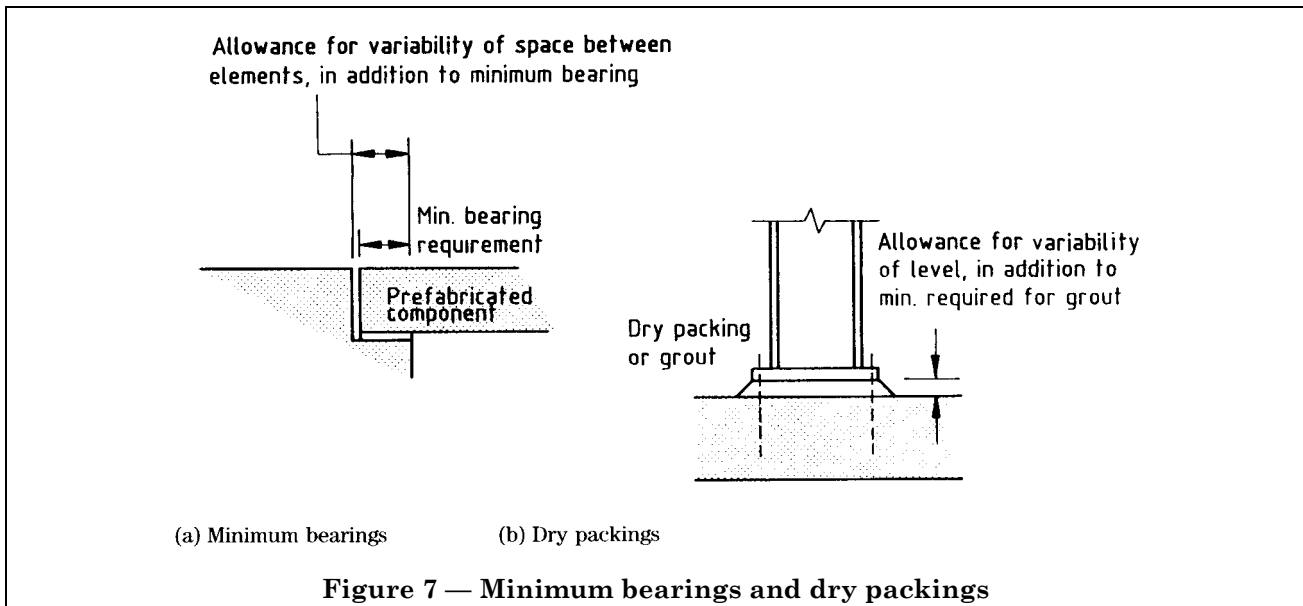

Figure 7 — Minimum bearings and dry packings

10 Specifying tolerances

Tolerances should be specified which reflect the following:

- a) the dimensional tolerance needs of the design;
- b) the particular requirements of the various elements and components of the construction.

When normal accuracy (see clause 8) is appropriate, the specification need refer only to Table 1 and Table 2 of this standard.

When special accuracy is required for particular details, joints and interfaces, sizes with their associated tolerances should be shown on the drawings and in the specification. See Figure 8 for guidance concerning the dimensional needs of a design.

Consideration should be given to the need to specify trials and to carry out the construction of mock-ups for particular areas or items of the construction.

Project specifications should include specific requirements for monitoring compliance, including the method of measurement to be employed (see clause 13).

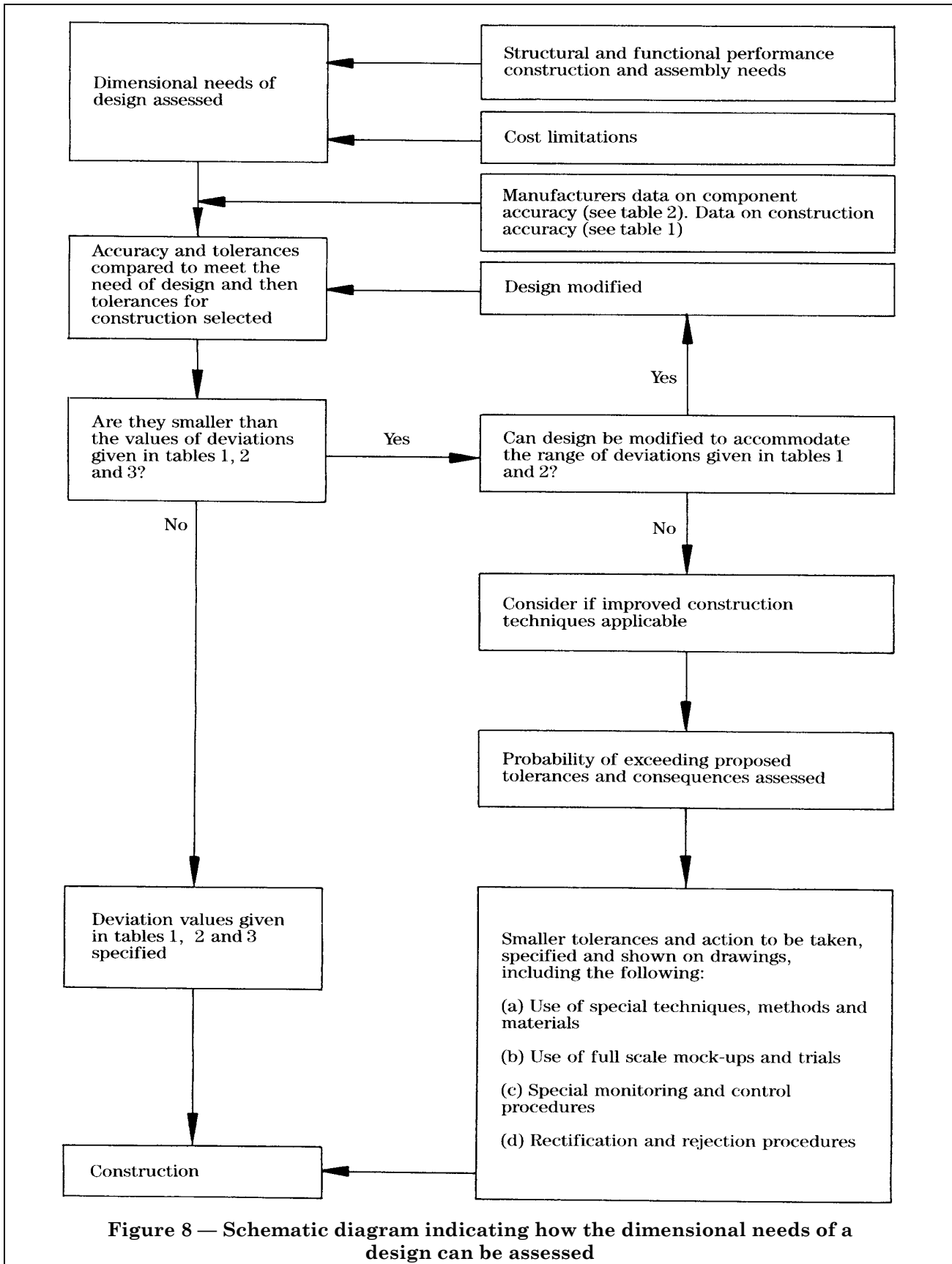

Licensed Copy: Giorgio Cavalleri, none, 15-Nov-00, Uncontrolled Copy. © BSI

Figure 8 — Schematic diagram indicating how the dimensional needs of a design can be assessed

Section 4. Construction considerations

11 Accuracy in construction

To aid compliance with the tolerances specified for a particular project, attention should be given to the following:

- a) identification of those areas of a project where the constructional details and dimensions are critical;
- b) assessment of the constructional details for constraints on tolerance and practical achievement of fit, e.g. for structural frame and components, claddings and finishes;
- c) planning and establishment of appropriate setting out, systematic monitoring, recording and reporting procedures on site;
- d) monitoring of the accuracy achieved during construction.

12 Sources of induced deviations

12.1 Induced deviations in the setting out process

Sources of induced deviations in the setting out process include the following:

- a) human inability to measure with absolute accuracy;
- b) inaccuracy in the site survey which will affect the position of grid stations or grid lines established from them;
- c) inaccuracy in the position or direction of grid lines which will affect the location of construction elements and components;
- d) inaccuracy in the establishment of a site temporary bench mark (TBM) which will affect all subsequent levelling work;
- e) inaccuracy of measuring instruments and their associated equipment.

The accuracy which can be achieved in setting out depends upon that of the site survey (see Appendix A), the choice of equipment to be used in setting out, the competence of the personnel involved and the selection of the methods to be used for particular tasks.

12.2 Induced deviations in manufacturing and construction

Sources of induced deviations in manufacturing and construction (due to the material from which a component or element is made, and the manufacturing process) include the following:

- a) deviations, in size or shape of components, which arise during the manufacturing process and which cause dimensional variation between similar finished products which are intended to be identical;

b) variability of dimensions and of shape in formwork;

c) deflection of formwork and the settlement of its supports and props.

Moulds, jigs or other equipment influencing a manufactured size should be checked before and during component manufacture since errors can create systematic error in the product. Component dimensions relevant to fit should be measured as early as practicable after manufacture begins and the process should be corrected if necessary so that subsequent components can comply with the tolerances specified for the project.

12.3 Induced deviations in the erection and assembly process

Sources of induced deviations in the erection and assembly process include:

- a) inability to locate building components exactly on setting out marks;
- b) insufficient adjustability in fixings; e.g. clearance should be present in bolt holes to enable the bolts to pass through;
- c) inaccuracy present in measuring instruments, particularly those for obtaining verticality.

Supervision of the erection process is essential to ensure that components are placed in position within the tolerances specified for the project.

Deviations from the intended position should be minimized by providing appropriate means of handling and of controlling the movement of components, particularly heavy components.

13 Control of accuracy during construction

13.1 Monitoring

Checking should be systematic and should be undertaken at all stages of construction starting with setting out, kickers, shuttering, manufacture, position in line, level, assembly and final construction. Particular attention should be given to the monitoring of construction in areas where the work of following trades, or prefabricated components, would be affected in appearance or performance.

Aspects that should be considered include the following:

- a) agreed monitoring and control procedures including measuring sequences and number of elements and components to be monitored. For example: guidance on setting out can be obtained from BS 5964;

- b) guidelines given in BS 7307 indicating methods of measurement of building and building products, which can be used to standardize the monitoring procedure;
- c) method of use and accuracy in use of measuring instruments, which should be appropriate to the accuracy specified. See 7.3.

13.2 Dimensional control

Dimensional control should be achieved by:

- a) checking that measured results are within the tolerances specified for the project; (see 13.1);
- b) identifying sources of induced inaccuracy (see clause 12);
- c) taking appropriate corrective action (see 13.5).

13.3 Recording

The dimensions measured should be systematically recorded for the following:

- a) checking compliance;
- b) preparing record drawings showing the measurements achieved in practice and the deviations from the target size;
- c) establishing characteristic accuracy.

13.4 Presentation of dimensional accuracy data

Guidance is given in BS 7308, concerning the principles on which the presentation of dimensional accuracy data should be based, and the format in which this data should be presented for defined items of construction and manufactured components.

13.5 Corrective action

Corrective action in respect of work that does not comply with the tolerances specified for a project can include:

- a) rectification of work already done;
- b) adjustment of methods or materials used;
- c) increasing supervision at identified sources of inaccuracy;
- d) adjustment of design and/or details.

13.6 Preventive action

Systematic checking as the work proceeds is essential to make sure that the adopted methods, monitoring and control systems are adequate.

Preventive action can be indicated from an assessment of the results of the monitoring, particularly at the initial stages of each process. This will permit the problems to be identified and addressed at an early stage.

Errors occurring early in the construction process and not discovered at the time can be difficult and expensive to rectify later.

Appendix A Site surveys

A.1 General

A site survey, of standard appropriate to the complexity of the construction, is of fundamental importance in the design and construction of a building. It is important therefore that a comprehensive brief is prepared listing the type of information that is required and the accuracy to which it is needed. Requesting unrealistically high accuracies can add considerably to both time and cost.

Site surveys should be plotted on a material, such as stable plastic film, using a coordinate system which lends itself to computer manipulation. The results of a survey can be supplied in digital form on a disc. This allows the information needed to be plotted out at any particular stage.

A survey plan will usually show the following information:

- a) location of the site in relation to features in the vicinity;
- b) position of site boundaries together with building, improvement and development lines as appropriate;
- c) calculated area of the site;
- d) ground levels by means of spot levels either on a regular grid or at high and low points on a random grid, related to the Ordnance Survey datum. Spot levels may be presented as contours;
- e) position of existing features on or adjacent to the site that may influence, or be influenced by, the new construction;
- f) position and types of all services existing on, over and under the site and its environs, with levels of pipe inverts and manhole covers, depths or heights of service lines;
- g) position of survey stations and their coordinates together with check dimensions to existing features. This will enable the position of the proposed new construction to be related to the survey lines. Each survey station mark should be left in as permanent a form as possible;
- h) position and value of all Ordnance Survey bench marks in the vicinity indicating which one has been used as the datum for the levels survey.

In addition to the site survey, building surveys of adjacent properties may be needed showing elevations and cross sections of existing walls, foundations and floor levels so that the new construction can be married correctly with the existing construction.

A.2 Accuracy of site surveys

The required accuracy of the site survey should be stated clearly in a brief.

Site surveys can be carried out by a range of methods using theodolites, electro magnetic distance measuring (EDM) instruments or tapes, but should be no less accurate than a traditional traverse survey with theodolite and steel tape. See also Table 3.

The survey should provide a framework of control lines with interconnections arranged in such a fashion that site details can be readily fixed by measurement from the lines and related stations.

The accuracy of both the framework stations and the detail points can be expressed in fractional form (for example 1/5 000 or 1/10 000) but the accuracy for detail will normally be different from the accuracy for the framework. These fractions represent the ratio between dimensions given on the survey drawing and those which can be expected when checking physically between two stations or two detail points on site.

If the design values for the accuracy of the site survey have been achieved, then any misclosures that have had to be distributed should not affect subsequent work that relies on the main survey stations.

When surveys are carried out using 20" or 1" glass arc theodolites, or their electronic equivalents, and carbon steel tapes or EDM instruments with the appropriate corrections applied, the probable deviations between points are as follows:

- ± 5 mm to ± 10 mm in 50 m
- ± 15 mm in 100 m
- ± 12 mm in 200 m using EDM
- ± 15 mm in 500 m

Any greater distances would be measured by EDM and would give varying accuracies according to the make and model of instrument used.

It is appropriate to plot these surveys to a 1 : 500 scale, although if additional care is taken with the observations it is feasible to obtain results commensurate with plotting the surveys at 1 : 200 or 1 : 100.

For all types of survey the accuracy of level values should be as follows:

- a) site TBM relative to Ordnance Survey bench mark ± 10 mm;
- b) spot levels relative to site TBM ± 10 mm: on hard surfaces 90% should be to ± 5 mm.

A land surveyor's advice should be sought if, in exceptional circumstances, even greater accuracy is required.

Table 3 — Accuracy in use of measuring instruments

Measurement	Instrument	Range of deviations	Comment (see also NOTE)
T.3.1 Linear	30 m carbon steel tape for general use	± 5 mm up to and including 5 m ± 10 mm for over 5 m and up to and including 25 m ± 15 mm for over 25 m	With sag eliminated and slope correction applied
	30 m carbon steel tape for use in precise work	± 3 mm up to and including 10 m ± 6 mm for over 10 m and up to and including 30 m	At correct tension and with slope, sag and temperature corrections applied
	Electronic distance measuring (EDM) instruments (short range models) for general use	± 10 mm for distances over 30 m and up to 50 m ± (10 mm ± 10 p.p.m.) ^c for distances greater than 50 m	Accuracies of EDM instruments vary, depending on make and model of instruments. Distances measured by EDM should normally be greater than 30 m and measured from each end.
	Precise work	± (5 mm ± 5 p.p.m.) ^c	
T.3.2 Angular	Opto-mechanical (e.g. glass arc) theodolite ^a (with optical plummet or centering rod) reading directly to 20"	± 20" (± 5 mm in 50 m)	Scale readings estimated to the nearest 5". Mean of two sights, one on each face with readings in opposite quadrants of the horizontal circle.
	Opto-mechanical (e.g. glass arc) theodolite (with optical plummet or centering rod) reading directly to 1"	± 5" (± 2 mm in 80 m)	Mean of two sights, one each face with readings in opposite quadrants of the horizontal circle.
	1" opto-electronic theodolite/total station	± 3" (± 1 mm in 50 m)	Mean of two sights, one on each face with readings in opposite quadrants of the horizontal circle.

Table 3 — Accuracy in use of measuring instruments

Measurement	Instrument	Range of deviations	Comment (see also NOTE)
T.3.3 Verticality	Spirit level	± 10 mm in 3 m	For an instrument not less than 750 mm long
	Plumb-bob (3 kg) freely suspended	± 5 mm in 5 m	Should only be used in still conditions
	Plumb-bob (3 kg) immersed in oil to restrict movement	± 5 mm in 10 m	Should only be used in still conditions
	Theodolite (with optical plummet or centering rod) and diagonal eye-piece	± 5 mm in 30 m ^b	Mean of at least four projected points, each one established at a 90° interval
	Optical plumbing device	± 5 mm in 100 m	Automatic plumbing device incorporating a pendulous prism instead of a levelling bubble
	Laser upwards or downwards alignment	± 7 mm in 100 m	Four readings should be taken in each quadrant of the horizontal circle and the mean value of readings in opposite quadrants accepted Appropriate safety precautions should be applied according to power of instrument used
T.3.4 Levels	Spirit level	± 5 mm in 5 m distance	Instrument not less than 750 mm long Sensitive to temperature variation
	Water level	± 5 mm in 15 m distance	
	Lightweight self-levelling level	± 5 mm in 25 m distance	Where possible sight lengths should be equal
	Optical level		
	a) “builders” class	± 5 mm per single sight of up to 60 m ^b	
		b) “engineers” class	± 3 mm per single sight of up to 60 m ^b ± 10 mm per km
	c) “precise” class	± 2 mm per single sight of up to 60 m ± 8 mm per km	
	Laser level (visible light source) (invisible light source)	± 7 mm per single sight up to 100 m ± 5 mm per single sight up to 100 m	
NOTE Equipment should be checked periodically according to BS 7334.			
^a If a single sighting only is made when using a correctly adjusted theodolite to establish an angle the likely deviations will be increased by a factor of 3. Therefore, a single sight should not be taken.			
^b Value based on measured data.			
^c Parts per million of measured distance.			

Appendix B Examples of the calculation of tolerances

B.1 General

This guide refers to the range of deviations for a wide selection of items of construction (see 8.1) and of manufactured components (see 8.2). These deviations are given in Table 1 for items of site construction and in Table 2 for manufactured components, and can be used to provide an initial assessment of the likelihood of achieving satisfactory fit during construction. These limits apply for normal methods of construction and manufacture and include the contributions of the constituent variabilities. The rate of misfit associated with the range of deviations given in Table 1 and Table 2 is approximately as follows:

- a) 4.5 % (1 in 22) for items of construction;
- b) 1.25 % (1 in 80) for manufactured components.

Different rates of misfit have been quoted to take practical account of the repetition which generally applies to the manufacture of components. The differences in these rates of misfit are ignored in obtaining the initial assessments of the likelihood of fit. The estimate obtained assumes the following:

- a) the contribution of the systematic deviation is small compared to the total variability;
- b) the number of manufactured infill components are few;
- c) the variability associated with the component or components is small compared to the variability associated with the constructed space.

For those designs for which any of the assumptions 1), 2) or 3) are invalid, or for which a full assessment is needed, the recommendations of BS 6954-3 should be applied to assess the dimensional needs of the design.

B.2 Examples concerned with the insertion of a manufactured component into a prepared space

B.2.1 General

Example B.2.2 is concerned with the insertion of a manufactured component into a space and enables an initial assessment to be made of the maximum and minimum joint size that will enable a jointing technique to accommodate a known dimensional variability in space and component size.

B.2.2 Insertion of a window frame into a prepared opening (determining the range of possible joint sizes)

NOTE Subclauses B.2.2.1 and B.2.2.2 deal with construction for fitting timber framed windows into a prepared space between two unplastered, cast in situ concrete columns.

B.2.2.1 Single window frame fitted into a prepared opening (see Figure 9)

Calculate the range of joint sizes when a timber window frame (target size 2390) is to be fitted into a space between in situ concrete columns (target size 2430).

Variability information	Deviations
Space between columns: in situ concrete: Table 1 (T.1.1)	± 18 mm
Length of component: timber Table 2 (T.2.1)	± 4 mm
Number of components	1

Calculation of target size of joints

$$\text{Target size of joints} = \frac{2430 - 2390}{2} = 20 \text{ mm each side}$$

Total deviation in size of joints

$$(\text{see 9.4}) = \sqrt{(18^2 \pm 4^2)} = \pm 18.4 \text{ mm}$$

$$\text{Max. joint size} = 20 + \frac{18.4}{2} = 29.2 \text{ mm}$$

$$\text{Min. joint size} = 20 - \frac{18.4}{2} = 10.8 \text{ mm}$$

The jointing technique should be capable of accommodating the maximum and minimum joint sizes i.e. say 30 mm to 10 mm.

If the jointing techniques available cannot accommodate the predicted range of variability, other options can be considered including the following:

- a) amend design to allow window to be fixed to the face of the columns;
- b) detail the columns with rebates to accommodate frame (see Figure 10);
- c) use a joint cover strip (see Figure 11);
- d) use more than one window, thus introducing more joints to accommodate variability (see B.2.2.2).

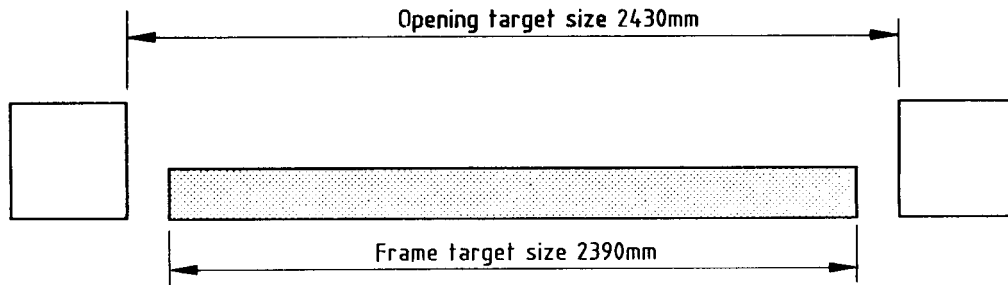

Figure 9 — Target sizes for a prepared opening, single window and joints

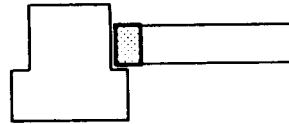

Figure 10 — Rebated column

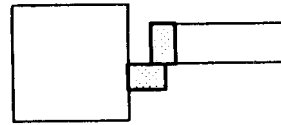

Figure 11 — Joint cover strip

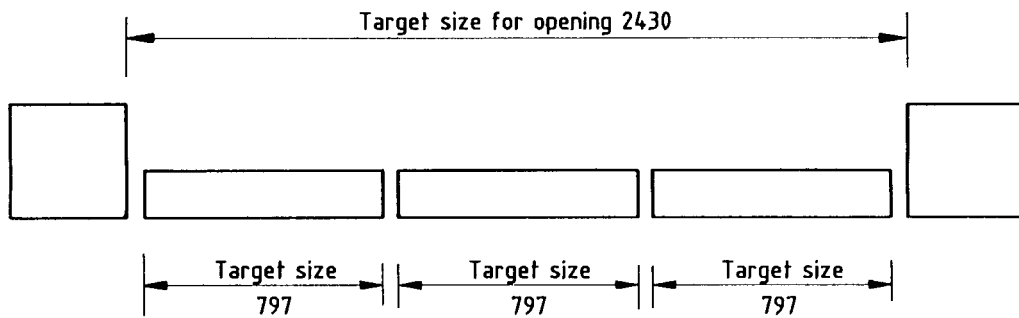

Figure 12 — Target sizes for a prepared opening, three windows and joints

B.2.2.2 Three window frames fitted into a prepared opening (see Figure 12).

Calculation of target size of joints

Number of components 3.

Number of joints 4

Total variability in size of joints

$$= \pm \sqrt{(18^2 + 4^2 + 4^2 + 4^2)} = \pm 19.3 \text{ mm}$$

$$\text{Target size of joints} = \frac{2430 - 2391}{4} = 9.8 \text{ mm each}$$

$$\text{Max. joint size} = 9.8 + \frac{19.3}{4} = 14.6 \text{ mm}$$

$$\text{Min. joint size} = 9.8 - \frac{19.3}{4} = 5.0 \text{ mm}$$

The jointing technique in this case should be capable of accommodating joint sizes in the range 15 mm to 5 mm.

Similar calculations should be made for vertical dimensions.

B.2.3 Line and level of concrete nibs supporting facing brickwork or other cladding

For the construction of in situ concrete nibs at the edge of floor slabs supporting facing brickwork six storeys in height (see Figure 13), the following should be considered.

- a) Position in plan, calculated tolerance on position of concrete nibs.

- 1) Ground floor level

Variability information (ground floor)

Setting out nearest reference line from building grid line (Table 3, T.3.1) = ± 5 mm up to 5 m

Position of face of concrete nib in relation to the nearest building grid line on the same level = ± 12 mm (Table 1 T.1.5). Total tolerance on position of nibs at ground level = $\sqrt{(5^2 + 12^2)} = \pm 13 \text{ mm}$

- 2) Upper floor levels

For first floor level and above, the tolerance for the face of the nib at each floor will be influenced by the method used to establish the building grid lines on each floor.

For the purposes of this example assume that grid lines on the first, second and third floors are to be established from grid lines on the ground floor using a theodolite. Also assume that the grid lines on the fourth and fifth floors and roof will be established from the grid on the third floor also using a theodolite.

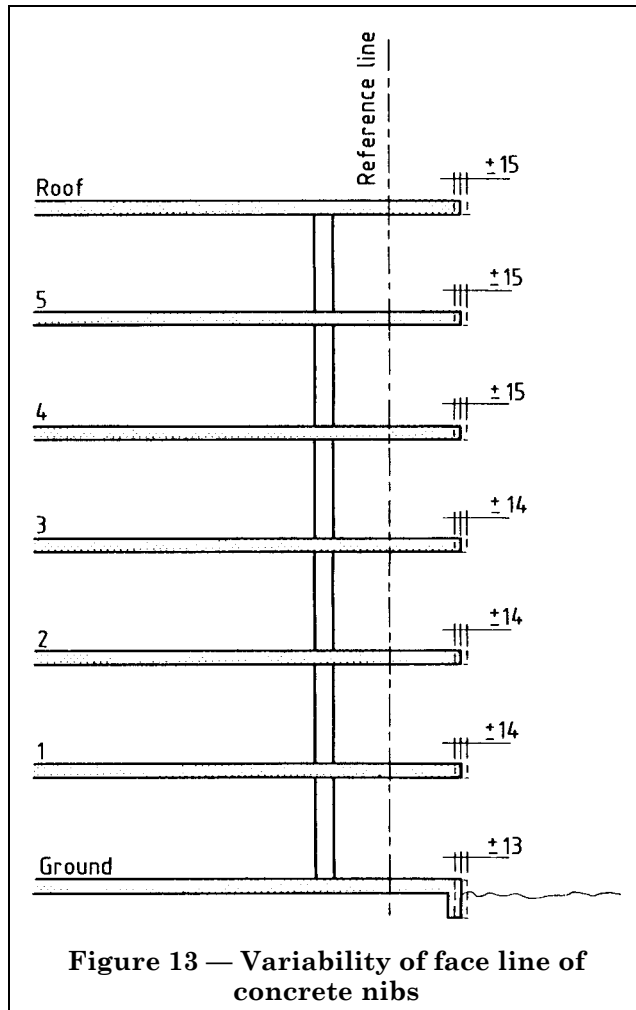

Figure 13 — Variability of face line of concrete nibs

Variability information (1st, 2nd and 3rd floors)	Deviations
Transferring a grid line from ground floor (Table 3, T.3.3)	± 5 mm in 30 m height
Setting out nearest reference line at each floor level by tape (Table 3, T.3.3) from grid line	± 5 mm in up to 5 m length
Position of face of nib relative to nearest grid line (Table 1, T.1.5)	± 12 mm
Total tolerance on position of nib (1st, 2nd and 3rd floors)	$= \sqrt{(5^2 + 5^2 + 12^2)}$ ± 13.9 say 14 mm

Variability information (4th, 5th, and 6th floors)	Deviations
Transferring grid line ground to third floor	± 5 mm
Transferring grid line third to sixth floor	± 5 mm
Setting out nearest reference line at each floor level	± 5 mm
Position of face of nib relative to nearest reference line	± 12 mm
Total tolerance on position of nib	$= \sqrt{(5^2 + 5^2 + 5^2 + 12^2)} = \pm 14.8$ say ± 15 mm

b) Position in plan, calculated tolerance on position of facing brickwork.

Position of face of brickwork relative to nearest reference line (Table 1, T.1.5) = ± 10 mm

Total tolerance on position of nib = ± 15 mm reference (see above)

\therefore Variability of bearing of brickwork on concrete nib = $\sqrt{(15^2 + 10^2)} = \pm 18$ mm.

From the calculations of B.2.3 the following observations can be made.

- 1) The edge of the concrete nibs can vary by up to ± 15 mm from a vertical plane.
- 2) The variability of the bearing of the brickwork on the concrete slab edge is ± 18 mm. The effect of this reduction in bearing on the stability of the brickwork should be considered. See Figure 14.

This example relates to brick cladding but it should be borne in mind that similar considerations will apply to other claddings. It is important that sufficient adjustment is provided in fixings to allow the cladding to be brought to a good plane. Adjustment in level should also be provided to enable a good horizontal line to be maintained.

It is recommended that a survey be made of the edges of the concrete nibs before setting the final position of the brickwork and/or cladding to ensure the bearings and/or connections perform as designed.

It should be noted that the effects of inherent deviations should also be taken into account (see 7.4).

B.3 Precast cladding around in situ column: determining minimum internal dimension of precast cladding to accommodate variability and insulation (see Figure 15).

Construction of 5 storey in situ concrete frame with precast cladding to columns. Column target size 300×400 . Minimum cavity cladding to column 50 mm. Storey height 3 500 mm.

For the cladding to fit to the column with a minimum cavity of 50 mm and to produce an acceptable external appearance, account should be taken of the following variabilities.

Variability information	Deviations
Setting out variability	± 5 mm
Transfer of grid vertically from base (T.3.3)	
Setting out nearest reference line (tape) (T.3.1)	± 5 mm
In situ concrete construction variability	± 12 mm
Column position on plan from nearest reference line (T.1.5)	
Column verticality (T.1.3)	16 mm
Column size on plan (T.1.3)	± 8 mm
Precast concrete cladding erection/size variability	
Cladding position on plan from nearest reference line (T.1.5)	± 10 mm
Cladding verticality (T.1.3)	14 mm
Cladding size on plan (T.2.1)	± 6 mm

Calculation of combined deviation

Combined deviation (DL_1) due to setting out variability

$$DL_1 = \pm \sqrt{(5^2 + 5^2)} = \pm 7.07 \text{ mm (setting out zone)}$$

Combined deviation (DL_2) due to in situ concrete construction variability

$$DL_2 = \sqrt{(12^2 + 16^2 + 7^2)} = \pm 21.19 \text{ mm (in situ column zone)}$$

Combined deviation (DL_3) due to precast cladding erection/size variability

$$DL_3 = \sqrt{(10^2 + 14^2 + 6^2)} = \pm 18.22 \text{ mm (precast cladding zone)}$$

Total combined deviation (DL_t) to establish total variability to be taken into account is given by

$$\begin{aligned} DL_t &= \pm \sqrt{\{(DL_1)^2 + (DL_2)^2 + (DL_3)^2\}} \\ &= \pm \sqrt{(7.07^2 + 21.19^2 + 18.22^2)} \\ &= \pm 28.82 \text{ mm (say 29 mm)} \end{aligned}$$

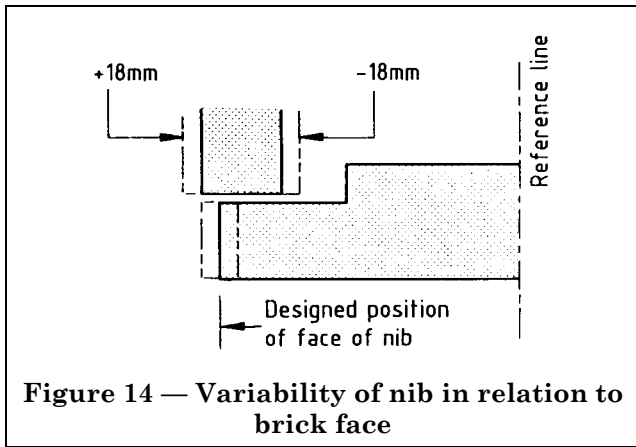

Variability information	Deviations
Suspended structural floor before laying screed material (in situ concrete)	Variation in level from target plane from Table 1 (T.1.3) ± 25 mm
Electrical trunking	Estimated thickness ± 0.5 mm
Level of screeded floor material (in situ concrete)	Variation in datum from target plane from Table 1 (T.1.3) ± 15 mm

B.4 Calculation of the minimum thickness of screeding to accommodate electrical trunking

Construction of in situ concrete ground floor slab with 15 mm p.v.c covered electrical trunking covered with a cast in situ screed (see Figure 16).

Calculation of target thickness of screed

$$\text{Total tolerance} = \sqrt{(25^2 + 0.5^2 + 15^2)} = \pm 29 \text{ mm}$$

Target thickness of screed to be achieved = minimum thickness

$$+ \text{thickness of trunking} + 29 \text{ mm}$$

The internal size of the precast cladding unit, providing also the required 50 mm cavity clearance, is given by

$$(300 + 50 + 50 + 29) = 429 \text{ mm}$$

Say for practical dimensioning, 430 mm internal size

A similar calculation should be carried out to establish the internal size of the cladding unit in the direction at right angles.

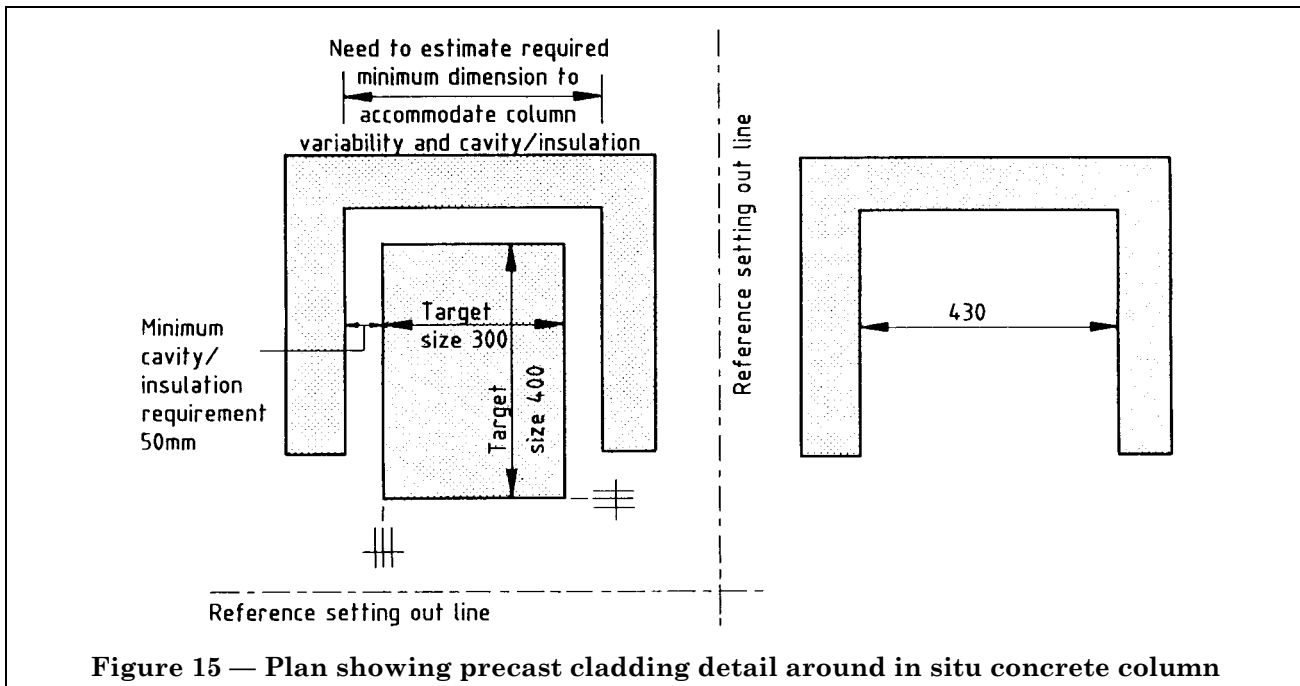

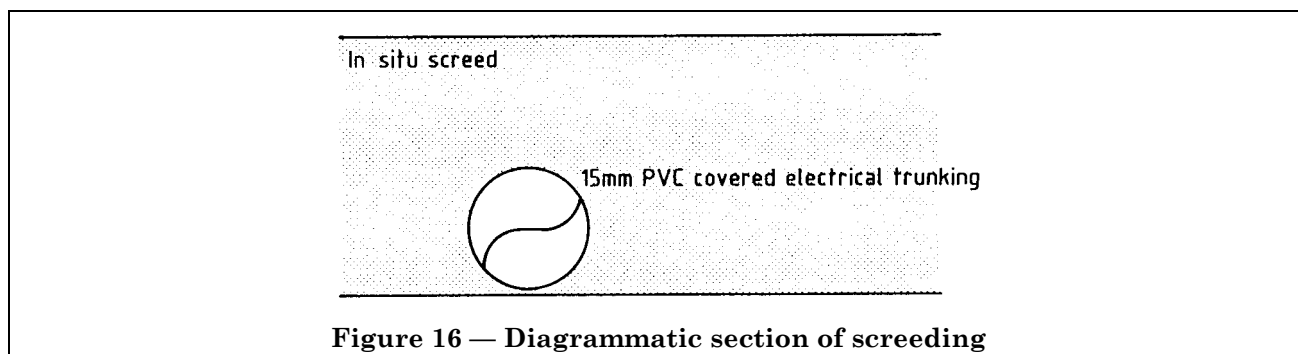

Figure 16 — Diagrammatic section of screeding

If the overall thickness of screed is considered excessive the following actions can be considered:

- a) recess trunking into concrete slab (if design permits);
- b) reduce minimum thickness over trunking but reinforce with mesh.

Consideration should be given to the possibility that the trunking will cross over other trunking services laid on the slab.

Recommendations given in 12.6 of BS 8203:1987 and 5.4.4 of BS 8204-1:1987, on pipes and trunking within the thickness of screeds should be considered in reaching an appropriate solution.

Appendix C Measured values of dimensional accuracy

C.1 Measurement surveys

C.1.1 Survey of constructed items

Measurements were made during the Building Research Establishment (BRE) survey (undertaken between 1975 and 1977) of the size and shape of building elements and the space between them for common constructional materials. The standardized methods used for measuring the particular dimensions chosen for the survey are summarized in Appendix D.

C.1.2 Survey of manufactured items

Measurements were made by the BRE, between 1986 and 1988, of the size and shape of manufactured components commonly used in building construction for common materials, namely precast concrete (both reinforced and prestressed), fabricated steel and timber.

C.2 Analysis of the measured data

The results of each survey showed that for each construction task, or each manufacturing process, normal methods of working resulted in a consistent pattern of dimensional variability. The variability occurs even when properly trained and fully experienced operatives using the correct procedures, materials and tools make genuine attempts to achieve the specified sizes. It arises because of the physical limitations of the operative and the inherent variability of the materials, tools and measuring equipment used. The magnitude of the variability varies from process to process and is characteristic of the process.

The surveys confirm that the accuracy of a process cannot be improved simply by specifying tighter tolerances. In order to improve the accuracy characteristic of a process it is necessary to change the method of working by the use of different materials or by the adoption of intrinsically more accurate construction (or manufacturing) and measuring techniques. Such actions are likely to incur greater costs than the acceptance of normal methods.

For any given process, the characteristic dimensional variability displays what statistically is known as a "normal" distribution about the mean value (see Figure 17). The shape of this distribution curve indicates the spread of the values about the mean value. The standard deviation (SD) is a measure of the extent of this spread about the mean value (see BS 6100-1.5.1 for a full definition of SD). In some processes, the mean value differs from the target value and this difference is termed the systematic deviation. Characteristic accuracy is expressed in terms of the SD and the systematic deviation (\bar{x}).

The shape of the normal distribution curve is such that a range of ± 1 SD about the mean value will include 68.27 % of sizes, ± 2 SD will include 95.45 % of sizes, ± 2.5 SD will include 98.75 % of sizes and ± 3 SD will include 99.73 % of sizes (see Figure 17).

C.3 Values of characteristic accuracy for construction and manufacture

Table 4 presents the survey data as values of characteristic accuracy for each of the items of construction and types of dimension measured. Separate values are given for common materials used in building construction. Similarly, information is given in Table 5 for manufacture of precast concrete (both reinforced and prestressed), fabricated steel and timber components.

Within Table 4 and Table 5, each systematic deviation \bar{x} has been obtained by subtracting the target size from each of the measured sizes. Thus a negative value of systematic deviation indicates a mean size which is smaller than the target size by \bar{x} mm, and vice versa for a positive value systematic deviation. See Figure 18.

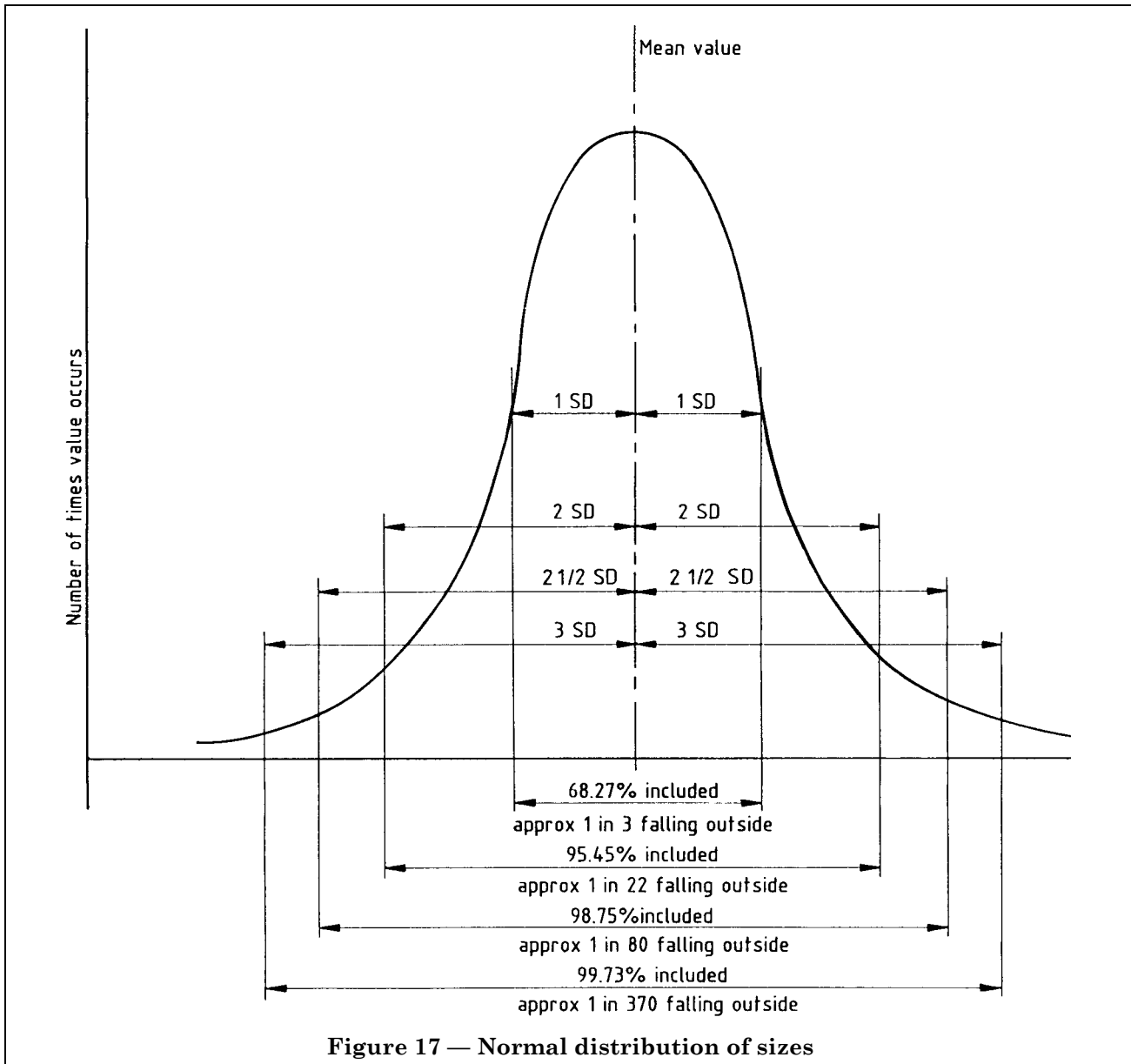

Licensed Copy: Giorgio Cavalleri, none, 15-Nov-00, Uncontrolled Copy. © BSI

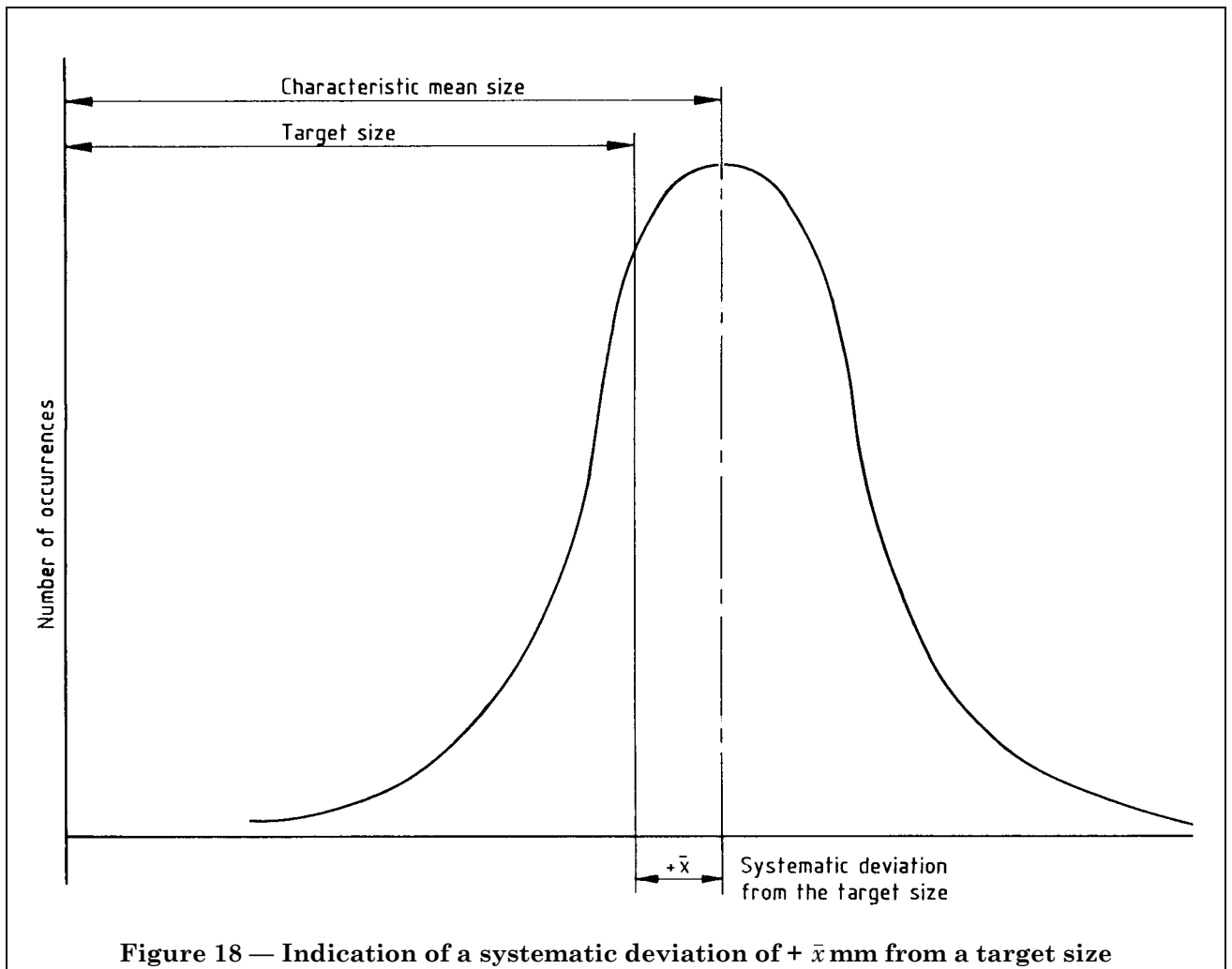

Table 4 — Characteristic accuracy values for construction determined from a Building Research Establishment survey from 1975 to 1976.
(All values are expressed in millimetres and are positive unless otherwise indicated)

Item of construction	Location	Data form ^a	Construction material													
			Brickwork		Blockwork		In situ concrete		Precast concrete		Steel		Timber			
			\bar{x} ^b	SD ^c	\bar{x} ^b	SD	\bar{x} ^b	SD	\bar{x} ^b	SD	\bar{x} ^b	SD	\bar{x} ^b	SD		
T.4.1 Space between elements	Walls	at floor	b	2.0	6.4	0.9	7.7	1.9	10.8	0.1	7.4	NA	NA	-0.8	13.2	
		at soffit	b	0.3	9.7	0.5	10.3	2.6	10.5	0.7	8.8	NA	NA	2.5	14.6	
	Columns	at floor	b	NA	NA	NA	NA	-1.9	7.3	0.1	6.6	-1.3	5.5	—	—	
		at soffit	b	NA	NA	NA	NA	-0.5	8.9	0.5	6.1	-0.8	4.8	—	—	
		Cased steel at floor	b	NA	NA	NA	NA	NA	NA	NA	NA	-1.7	7.1	NA	NA	
at soffit	b	NA	NA	NA	NA	NA	NA	NA	NA	-1.1	7.5	NA	NA			
Beams	Floor to soffit height	c	NA	NA	NA	NA	-2.0	10.7	2.2	8.6	—	—	—	—		
Floor slabs																
T.4.2 Openings	Window or door	Width up to 3 m (not jiggged)	p	3.6	8.1	—	—	0.4	6.6	-0.6	5.2	NA	NA	—	—	
		Height up to 3 m (not jiggged)	p	3.2	8.6	—	—	3.7	8.3	-0.1	5.0	NA	NA	—	—	
T.4.3 Size and shape of elements and components	Walls	Height up to 3 m	m	1,3	12.2	-2.9	12.7	—	—	—	—	NA	NA	—	—	
		Thickness	o	-2.3	8.6	—	—	—	—	—	—	NA	NA	—	—	
		Straightness in 5 m	L	0.4	2.2	0.1	2.8	-0.3	4.3	-0.2	3.0	NA	NA	—	—	
		Verticality in storey heights	up to 2 m	h	0.3	4.3	0.4	4.4	0.4	5.3	-0.2	3.7	NA	NA	-0.7	-6.9
			up to 3 m	h	1.0	4.5	—	—	-1.8	7.5	0.6	5.0	NA	NA	—	—
		Level of bed joints 3 m	h	0.6	5.1	1.0	6.0	NA	NA	NA	NA	NA	NA	NA	NA	
	Columns	Size on plan of any face, up to 1 m	k	NA	NA	NA	NA	-0.1	3.9	-0.2	2.6	—	—	—	—	
		Verticality in storey heights	up to 3 m	h	NA	NA	NA	NA	-0.8	5.7	0.1	4.8	0.5	2.8	—	—
			up to 7 m	h	NA	NA	NA	NA	—	—	—	—	0.5	3.6	—	—
		cased steel up to 3 m squareness	h	NA	NA	NA	NA	NA	NA	NA	NA	0.8	4.6	NA	NA	
	Beams	Depth	up to 600 mm	j	NA	NA	NA	NA	4.2	8.5	—	—	—	—	—	—
			(perimeter beams) over 600 mm	j	NA	NA	NA	NA	2.7	8.5	—	—	—	—	—	—
			(Internal beams) up to 600 mm	j	NA	NA	NA	NA	2.5	4.5	—	—	—	—	—	—
over 600 mm			j	NA	NA	NA	NA	2.0	6.9	—	—	—	—	—	—	
Level ^{de}		Variation from the target plane of any point on the surface	f, g	NA	NA	NA	NA	-0.6	10.8	2.3	10.4	4.2	8.1	—	—	

Table 4 — Characteristic accuracy values for construction determined from a Building Research Establishment survey from 1975 to 1976. (All values are expressed in millimetres and are positive unless otherwise indicated)

Item of construction	Location	Data form ^a	Construction material												
			Brickwork		Blockwork		In situ concrete		Precast concrete		Steel		Timber		
			\bar{x}^b	SD ^c	\bar{x}^b	SD	\bar{x}^b	SD	\bar{x}^b	SD	\bar{x}^b	SD	\bar{x}^b	SD	
T.4.3 (continued)	fSuspended structural floor before laying of screed	Level ^e (based on 2.5 m grid) Variation from the target plane of any point on the surface	e	NA	NA	NA	NA	4.2	10.6	-1.5	13.2	NA	NA	—	—
		Precast with in situ topping Level ^e (based on 2.5 m grid) Variation from the target plane of any point on the surface	e	NA	NA	NA	NA	NA	NA	-3.0	14.2	NA	NA	NA	NA
	Structural soffit	Level ^e (based on 2.5 m grid) Variation from the target plane of any point on the surface	e	NA	NA	NA	NA	0.5	9.3	2.2	8.1	NA	NA	—	—
	Panels	Length	q	—	—	—	—	—	—	—	—	NA	NA	-1.3	1.6
Height		q	—	—	—	—	—	—	—	—	NA	NA	-1.4	1.8	
T.4.4 Overall size (on plan)	Building	Length or width up to 40 m	d	0.6	14.0	—	—	2.9	11.5	3.4	17.5	-0.1	6.7	—	—
	Ground floor slab	Length or width	d	NA	NA	NA	NA	-0.6	13.7	—	—	NA	NA	NA	NA

^a See Appendix D.

^b \bar{x} is, in this guide, the displacement of the mean and is the mean of the values obtained by subtracting the space or work size from all the measured sizes for each item. Measurements were taken to the nearest millimetre.

^c SD is the standard deviation.

^d Level variability of beams is measured on the soffit of concrete beams but on the top of steel beams.

^e Variability of surface level has been expressed by considering the variability above and below the target plane, (defined with reference to an adjacent TBM) of each of the points levelled.

^f A suspended structural floor is one designed to span between edge supports.

Table 5 — Characteristic accuracy values for manufactured components determined from BRE survey, 1988 to 1989

Item	Type of dimension measured	Construction material											
		Precast reinforced concrete		Precast prestressed concrete						Fabricated steel		Timber	
		\bar{x}	SD	\bar{x}	SD	\bar{x}	SD	\bar{x}	SD	\bar{x}	SD	\bar{x}	SD
T.5.1 Overall size	Length												
	Overall size												
	up to 2 m	-0.1	2.3	-0.1	2.3	} -1.0	7.0	0.3	6.1	} -0.3	2.1	Length to bm: Panels -0.5	1.9
	2 m to 6 m	-0.3	3.4	-0.3	3.4								
	6 m to 10 m	0.5	4.6	0.5	4.6								
	10 m to 20 m	—	—	—	—	—	—	-3.5	8.3			-0.1	1.4
	20 m to 30 m	—	—	—	—	—	—	-5.7	12.1			0.1	1.1
	Width												
	up to 250 mm	0.6	1.2	0.9	3.1	0.9	3.1	1.3	2.9	—	—	—	—
	250 mm to 1.25 m	0.6	2.1	0.9	3.1	0.9	3.1	0.7	4.8	—	—	—	—
1.25 mm to 4.0 m	0.4	3.0	0.8	5.2	—	—	5.7	4.2	—	—	—	—	
Thickness or depth													
up to 0.5 m	1.2	1.8	1.2	1.8	0.9	3.6	-0.2	2.5	—	—	—	—	
0.5 m to 1.5 m	2.1	2.8	—	—	—	—	-0.2	2.5	—	—	—	—	
T.5.2 Shape	Position and size of cut outs and extensions												
	up to 0.5 m	0.8	2.5	—	—	2.9	5.6	2.9	5.6	—	—	—	—
	0.5 m to 10 m	-0.5	4.6	—	—	—	—	2.9	5.6	—	—	—	—
	Squareness up to 1.2 m	—	—	—	—	—	—	0.0	3.7	—	—	—	—
Position of internal holes													
up to 10 m	-0.7	5.4	-0.7	5.4	—	—	-0.7	5.4	—	—	Panels and frames 1.0	1.8	
T.5.3 Connections	Position of fixing plates or cleats												
	up to 2 m	0.2	2.5	-0.4	3.3	—	—	-0.4	3.3	-0.1	2.0	—	—
	2 m to 10 m	-1.0	5.0	-2.5	5.9	—	—	2.5	5.9	-0.1	2.0	—	—
	Position of centres of bolt holes												
	along length	0.7	3.5	0.6	4.0	—	—	0.6	4.0	0.1	1.8	—	—
	across width	0.7	3.5	0.6	4.0	—	—	0.6	4.0	-0.1	1.4	—	—
	within cluster	—	—	—	—	—	—	—	—	0.1	0.9	—	—
	in welded end plates	—	—	—	—	—	—	—	—	-0.1	1.3	—	—
within cluster	—	—	—	—	—	—	—	—	-0.1	0.9	—	—	
in base plates	—	—	—	—	—	—	—	—	-0.3	1.5	—	—	
in relation to holes	—	—	—	—	—	—	—	—	-0.3	1.5	—	—	

Appendix D The BRE survey of constructed items

D.1 Information collected

The nature of the information collected for each of the construction situations included in the survey demanded the use of a variety of measurement procedures. Therefore a series of 15 data forms, labelled "b" to "p" inclusive, were designed (for BS 5606:1978) which included:

- details of the measurement tools required;
- recommendations on the measurement techniques to be adopted;
- details of the type of construction;

- target sizes;
- actual sizes;
- specified tolerances with reasons.

Data from data form "a" (in BS 5606:1978) was used to obtain the relevant construction details for a given site and applied for each type of dimension surveyed on that site.

Techniques used in the BRE construction surveys are illustrated in Figure 19 to Figure 32.

The current techniques recommended for measurement are given in BS 7307.

The current methods recommended for the presentation of dimensional accuracy data are given in BS 7308.

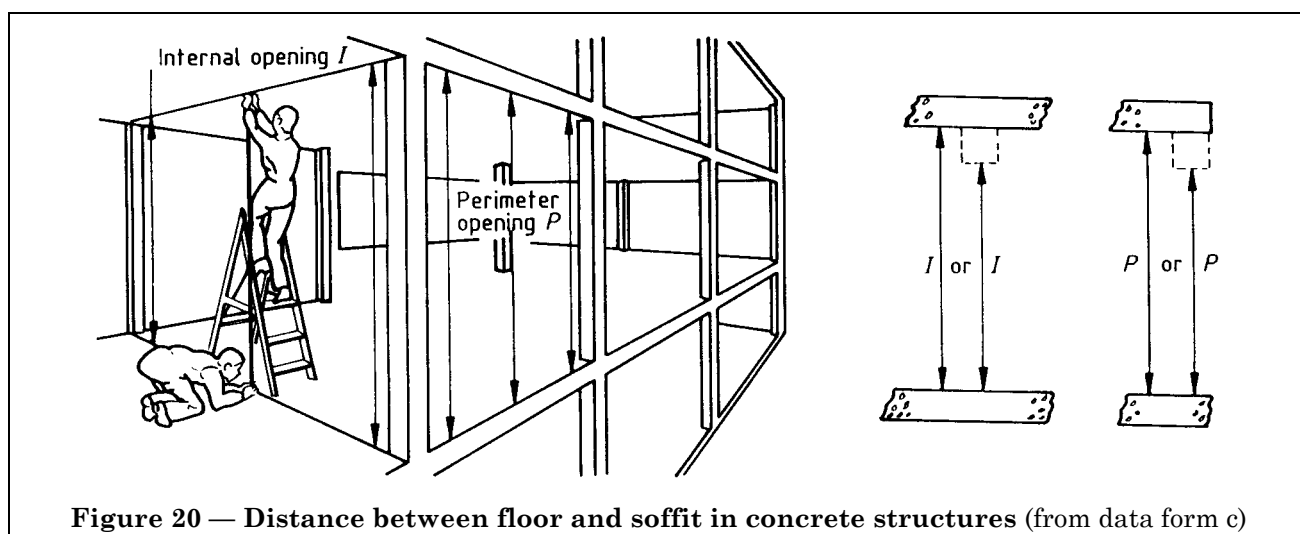
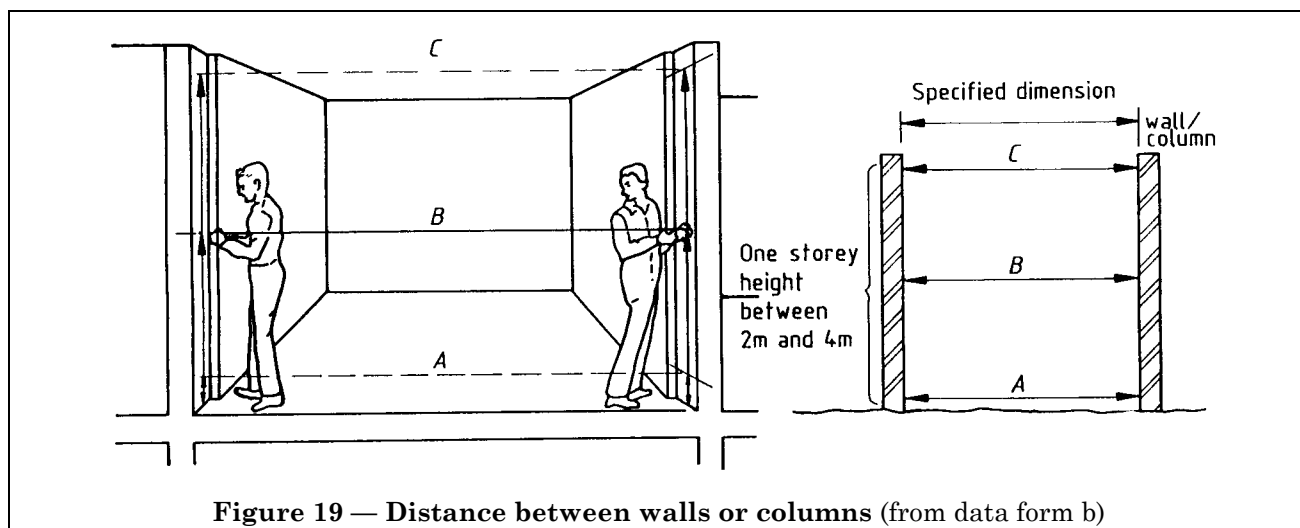

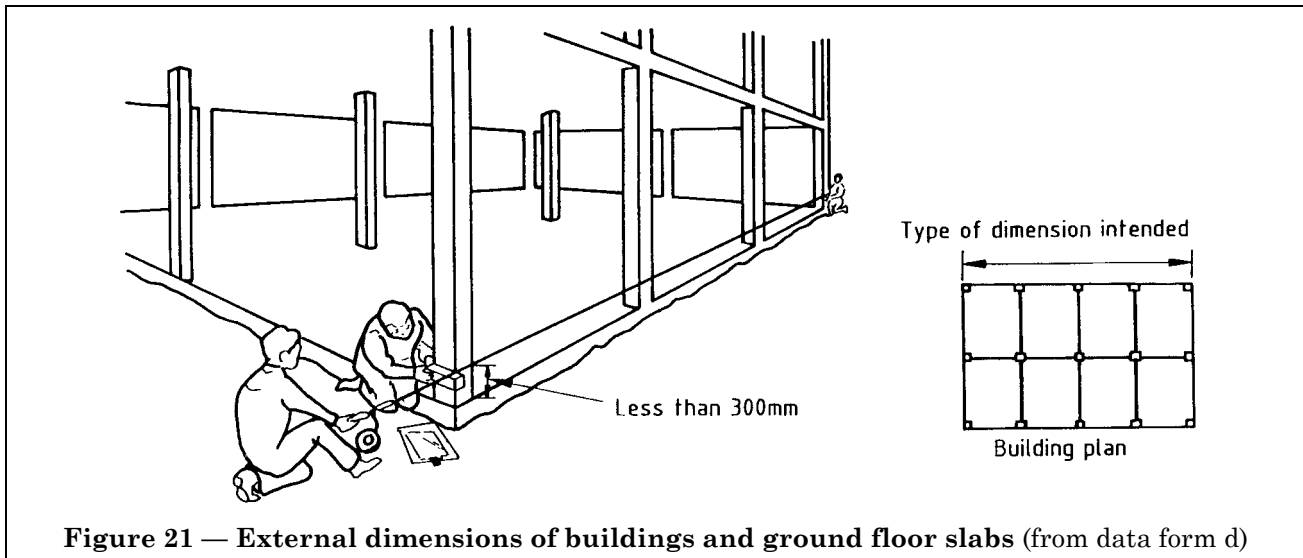

Figure 21 — External dimensions of buildings and ground floor slabs (from data form d)

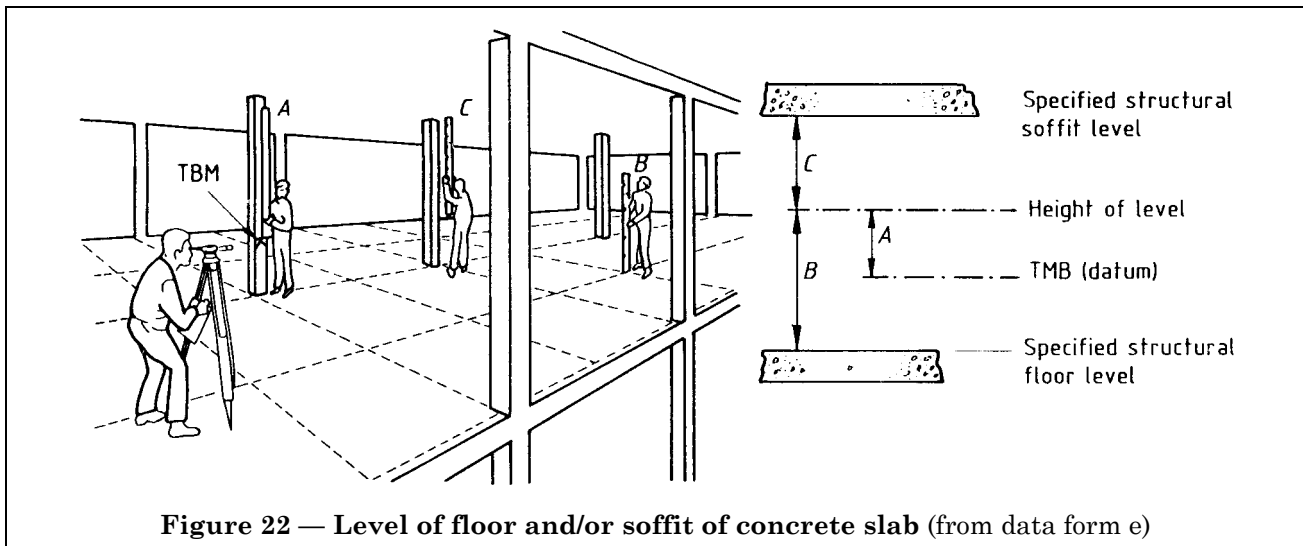

Figure 22 — Level of floor and/or soffit of concrete slab (from data form e)

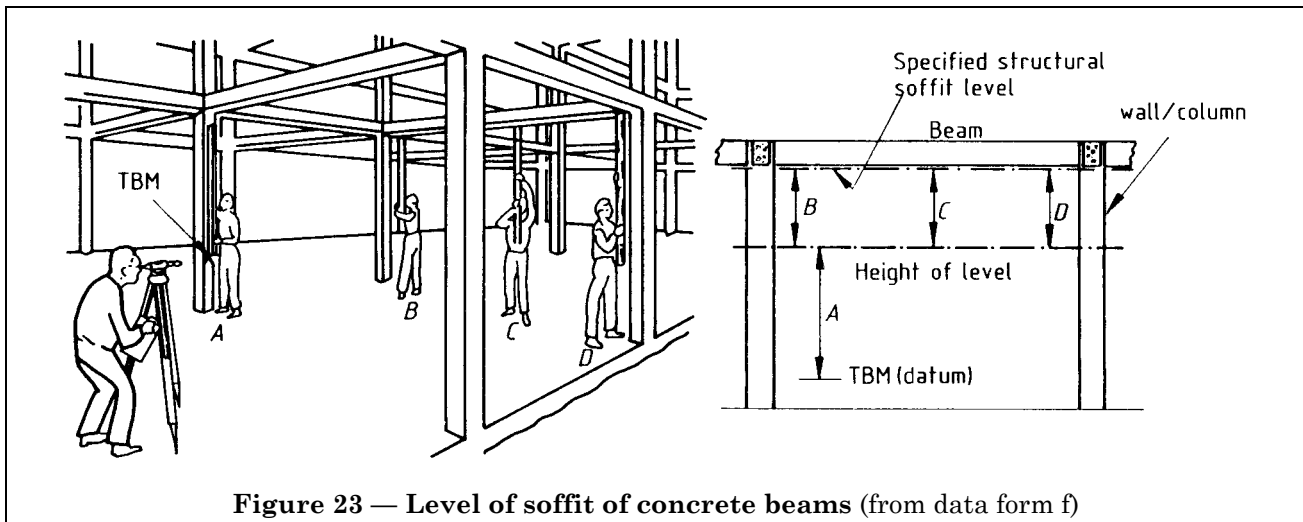
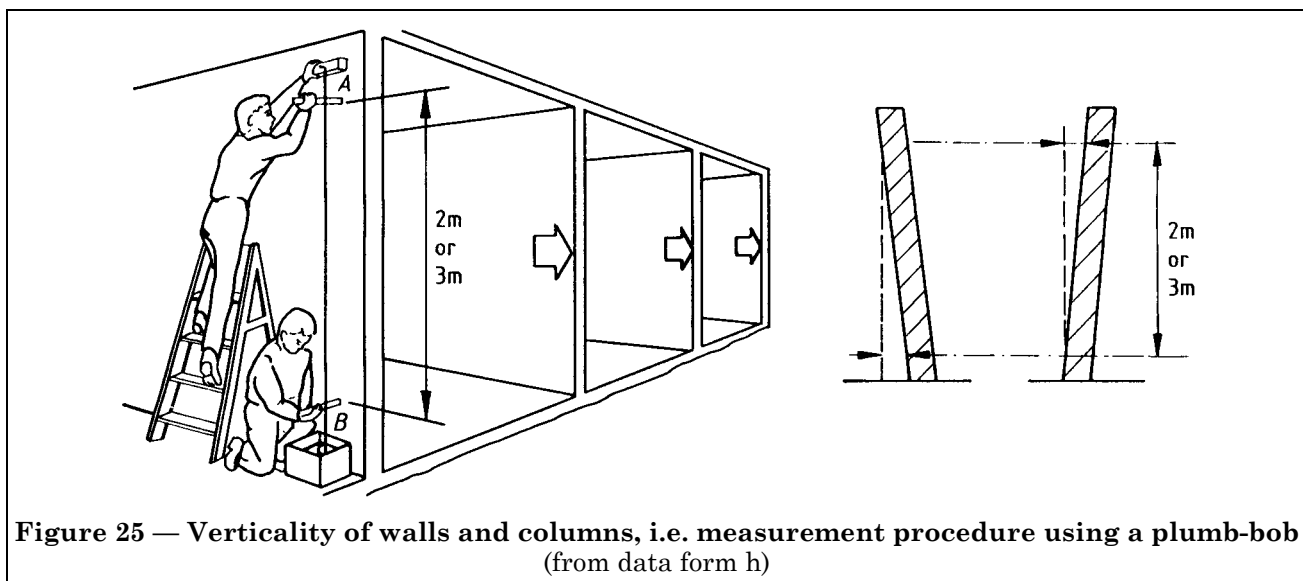
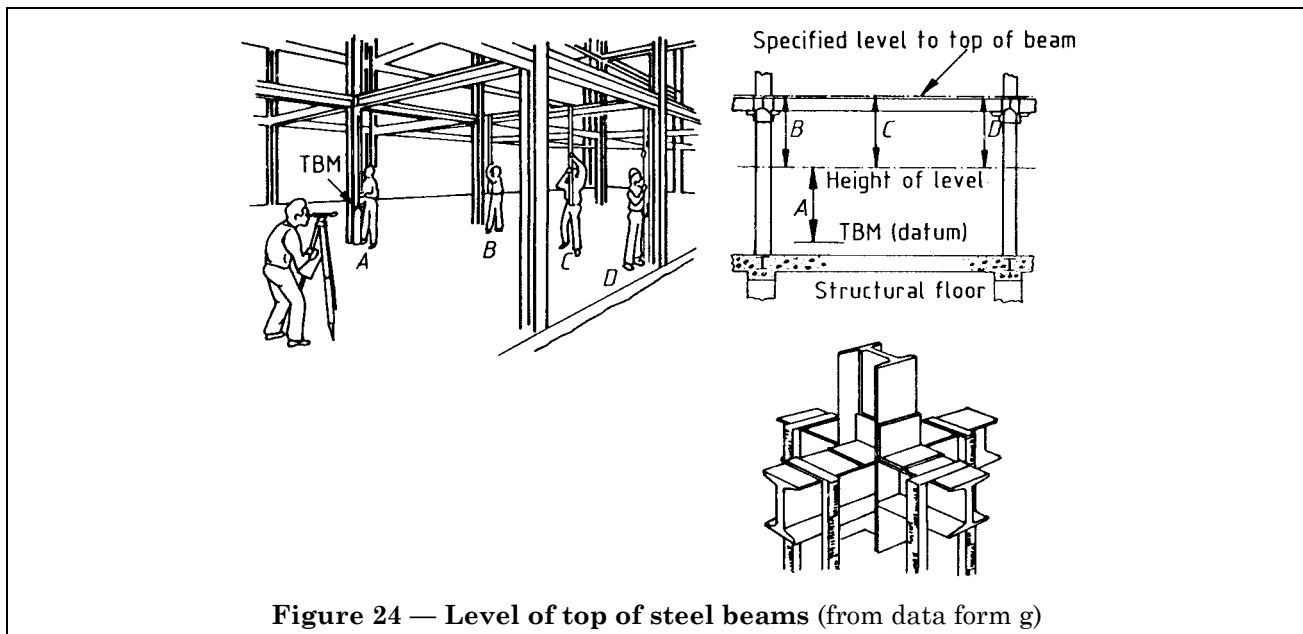

Figure 23 — Level of soffit of concrete beams (from data form f)



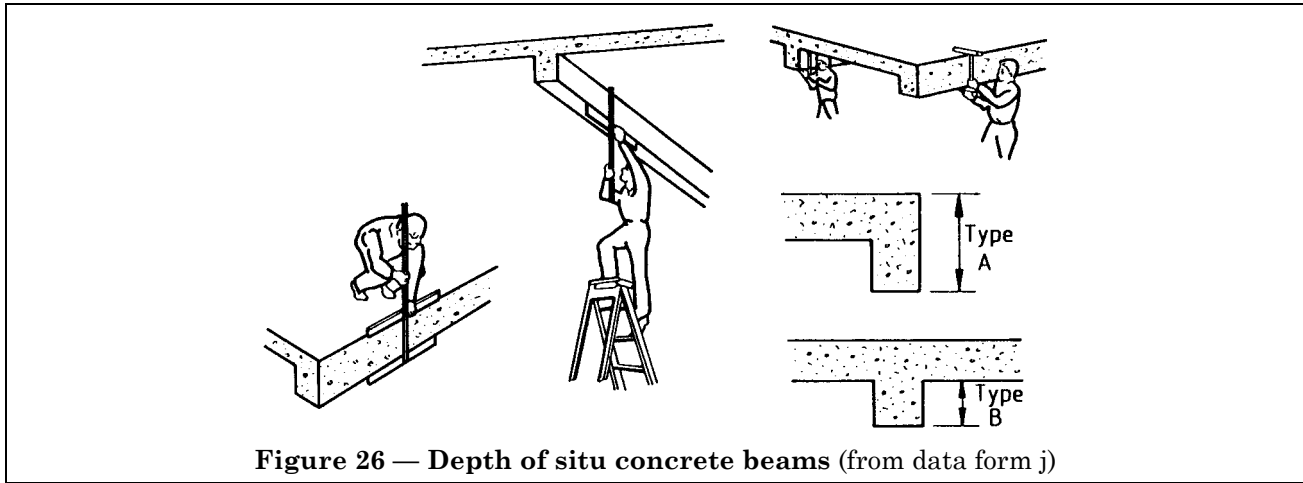

Figure 26 — Depth of situ concrete beams (from data form j)

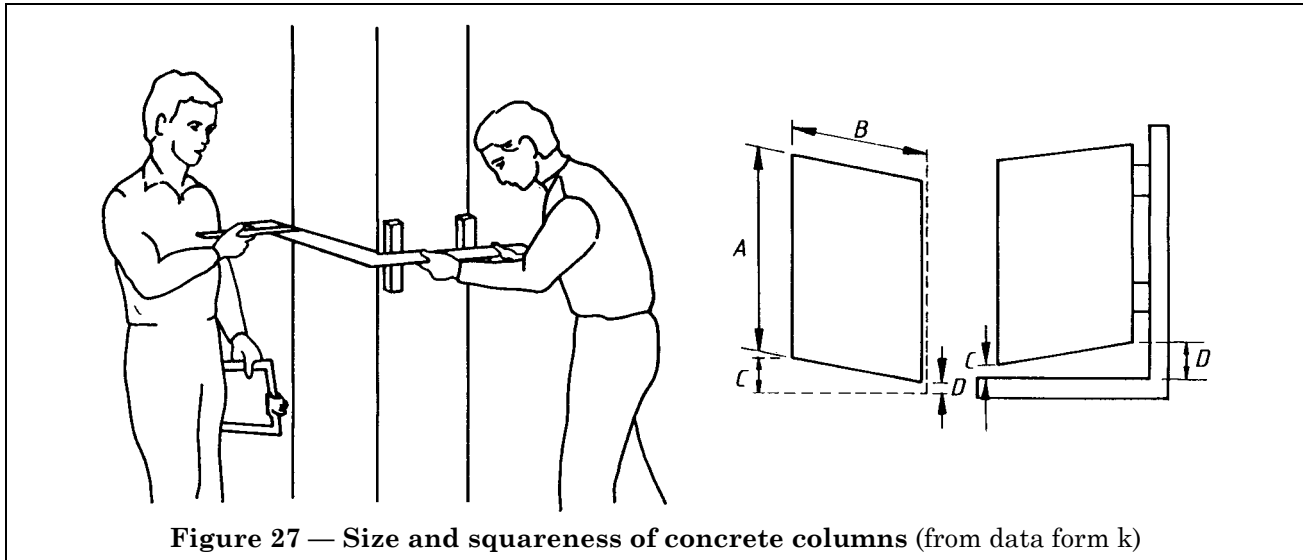

Figure 27 — Size and squareness of concrete columns (from data form k)

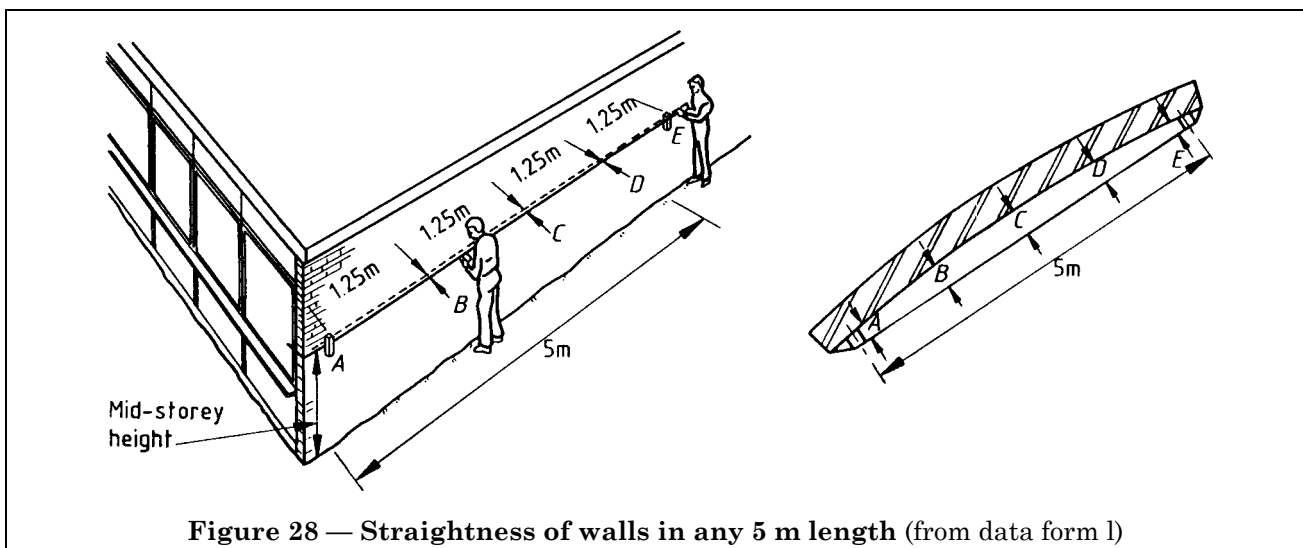
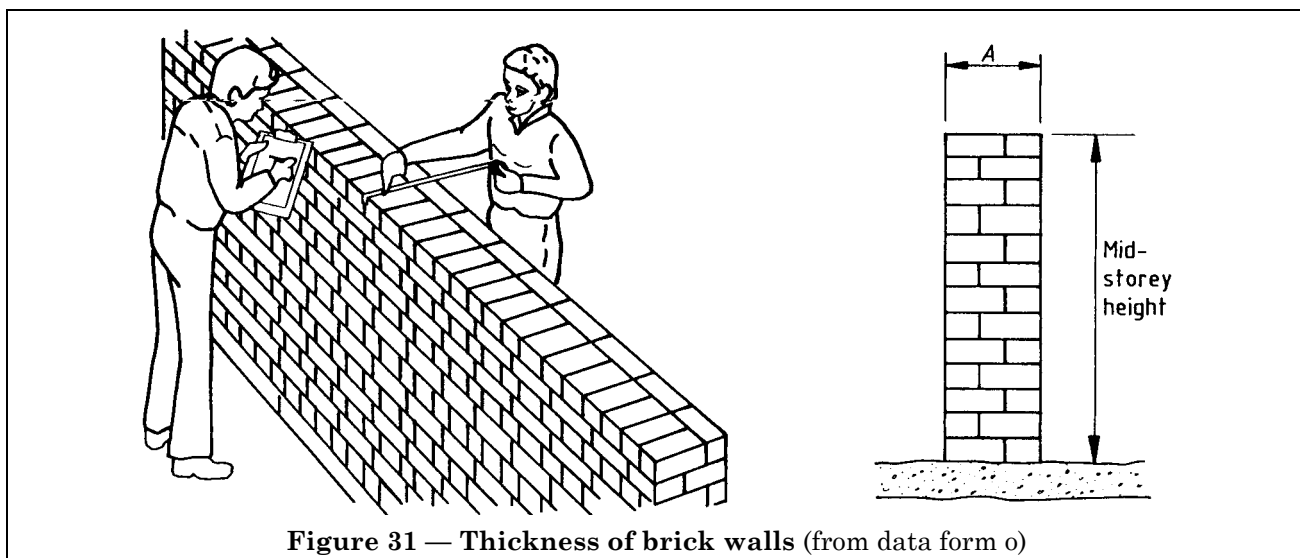
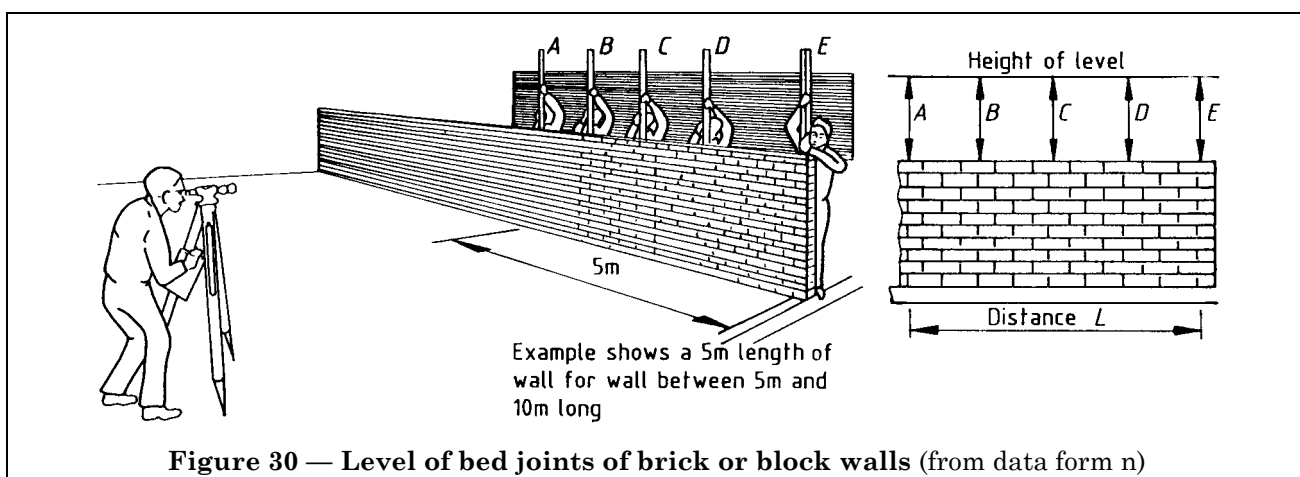
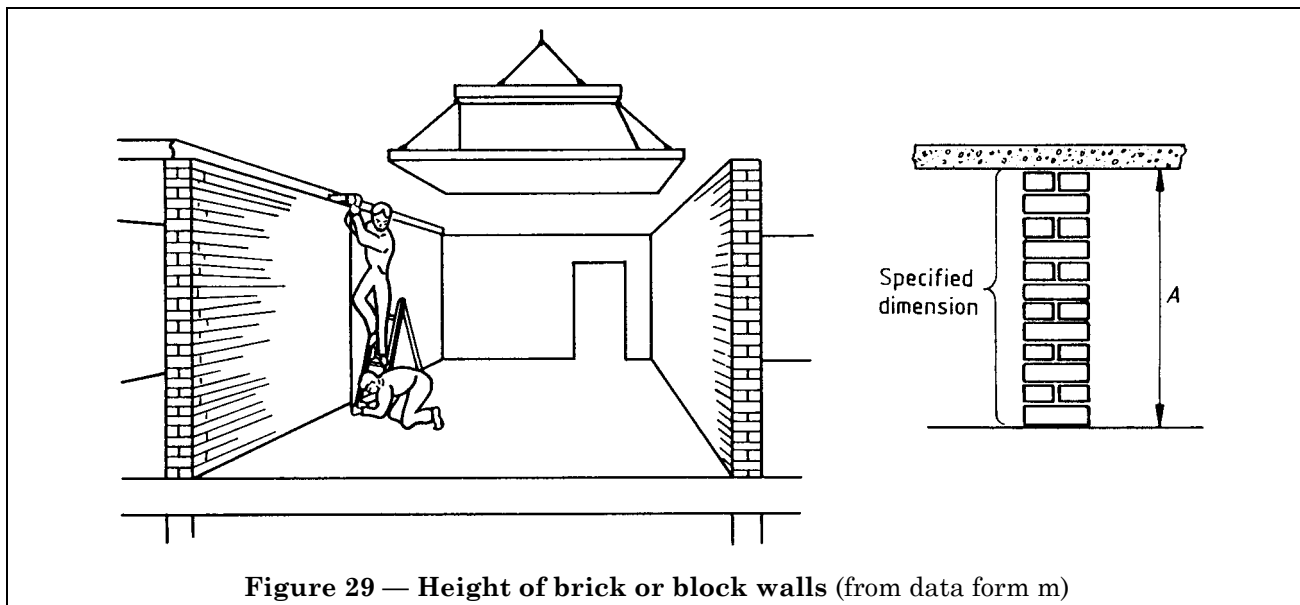

Figure 28 — Straightness of walls in any 5 m length (from data form l)



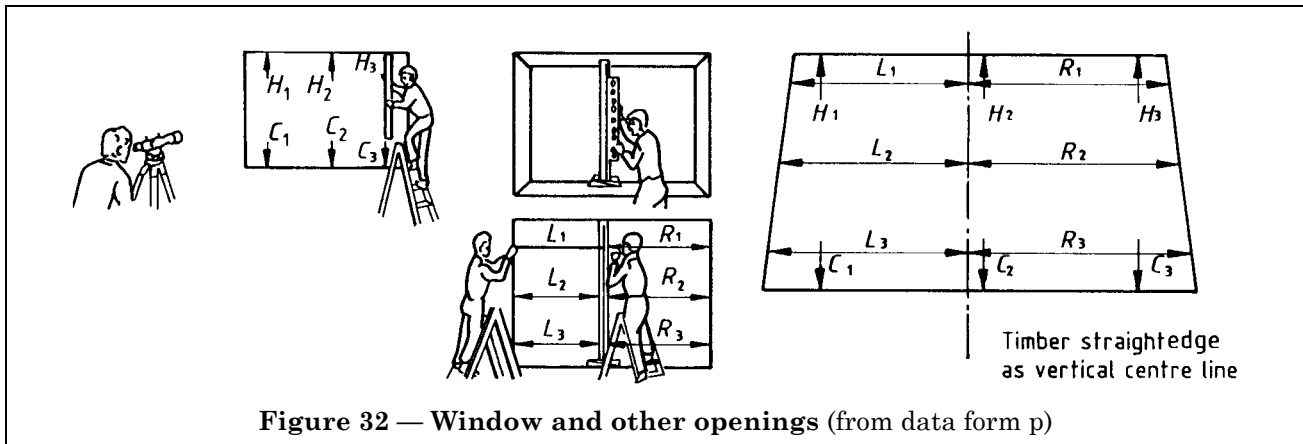

Figure 32 — Window and other openings (from data form p)

Publications referred to

- BS 5395, *Stairs, ladders and walkways*.
- BS 5655, *Lifts and service lifts*.
- BS 5655-5, *Specification for dimensions of standard electric lift arrangements*.
- BS 5655-6, *Code of practice for selection and installation*.
- BS 5964, *Measurement methods for building — Setting out and measurement — Part 1: Planning and organization, measuring procedures, acceptance criteria*.
- BS 6093, *Code of practice for design of joints and jointing in building construction*.
- BS 6100, *Glossary of building and civil engineering terms*.
- BS 6100-1.5.1, *Coordination of dimensions; tolerances and accuracy*.
- BS 6954, *Tolerances for building*.
- BS 6954-1, *Recommendations for basic principles for evaluation and specification*.
- BS 6954-2, *Recommendations for statistical basis for predicting fit between components having a normal distribution of sizes*.
- BS 6954-3, *Recommendations for selecting target size and predicting fit*.
- BS 7307, *Tolerances for building — Methods of measurement of buildings and building products*.
- BS 7307-1, *Methods and instruments*.
- BS 7307-2, *Position of measuring points*.
- BS 7308, *Tolerances for building — Method of presentation of dimensional accuracy data*.
- BS 7334, *Building construction — Measuring instruments — Methods for determining accuracy in use*.
- BS 7334-1, *Theory*.
- BS 7334-2, *Measuring tapes*.
- BS 7334-3, *Optical levelling instruments*.
- BS 7334-4, *Theodolites³⁾*.
- BS 7334-5, *Optical plumbing instruments³⁾*.
- BS 7334-6, *Laser instruments³⁾*.
- BS 7334-7, *Instruments when used for setting out³⁾*.
- BS 7334-8, *Electronic distance-measuring instruments³⁾*.
- BS 8203, *Code of practice for installation of sheet and tile flooring*.
- BS 8204, *In-situ floorings*.
- BS 8204-1, *Code of practice for concrete bases and screeds to receive in-situ flooring*.
- BS 8204-2, *Code of practice for concrete wearing surfaces*.
- BS 8298, *Code of practice for design and installation of natural stone cladding and lining*.
- CP 143, *Code of practice for sheet roof and wall coverings*.
- CP 297, *Precast concrete cladding (non-loadbearing)*.
- Technical Report No. 34:1988: *Concrete Industrial Ground Floors*, published by and available from the Concrete Society, Framewood Road, Wrexham, Slough, SL3 6TJ.

³⁾ In preparation.

BSI — British Standards Institution

BSI is the independent national body responsible for preparing British Standards. It presents the UK view on standards in Europe and at the international level. It is incorporated by Royal Charter.

Revisions

British Standards are updated by amendment or revision. Users of British Standards should make sure that they possess the latest amendments or editions.

It is the constant aim of BSI to improve the quality of our products and services. We would be grateful if anyone finding an inaccuracy or ambiguity while using this British Standard would inform the Secretary of the technical committee responsible, the identity of which can be found on the inside front cover. Tel: 020 8996 9000. Fax: 020 8996 7400.

BSI offers members an individual updating service called PLUS which ensures that subscribers automatically receive the latest editions of standards.

Buying standards

Orders for all BSI, international and foreign standards publications should be addressed to Customer Services. Tel: 020 8996 9001. Fax: 020 8996 7001.

In response to orders for international standards, it is BSI policy to supply the BSI implementation of those that have been published as British Standards, unless otherwise requested.

Information on standards

BSI provides a wide range of information on national, European and international standards through its Library and its Technical Help to Exporters Service. Various BSI electronic information services are also available which give details on all its products and services. Contact the Information Centre. Tel: 020 8996 7111. Fax: 020 8996 7048.

Subscribing members of BSI are kept up to date with standards developments and receive substantial discounts on the purchase price of standards. For details of these and other benefits contact Membership Administration. Tel: 020 8996 7002. Fax: 020 8996 7001.

Copyright

Copyright subsists in all BSI publications. BSI also holds the copyright, in the UK, of the publications of the international standardization bodies. Except as permitted under the Copyright, Designs and Patents Act 1988 no extract may be reproduced, stored in a retrieval system or transmitted in any form or by any means – electronic, photocopying, recording or otherwise – without prior written permission from BSI.

This does not preclude the free use, in the course of implementing the standard, of necessary details such as symbols, and size, type or grade designations. If these details are to be used for any other purpose than implementation then the prior written permission of BSI must be obtained.

If permission is granted, the terms may include royalty payments or a licensing agreement. Details and advice can be obtained from the Copyright Manager. Tel: 020 8996 7070.