



# Structural use of steelwork in building —

## Part 4: Code of practice for design of composite slabs with profiled steel sheeting

UDC 693.814:669.14.018.29-417.2:692.533.15

NO COPYING WITHOUT BSI PERMISSION EXCEPT AS PERMITTED BY COPYRIGHT LAW

---



# Committees responsible for this British Standard

The preparation of this British Standard was entrusted by Technical Committee B/525, Building and civil engineering structures, to Subcommittee B/525/4, upon which the following bodies were represented:

Association of Consulting Engineers  
 British Cement Association  
 British Constructional Steelwork Association Ltd.  
 British Masonry Society  
 Building Employers Confederation  
 Department of the Environment (Building Research Establishment)  
 Department of the Environment (Construction Directorate)  
 Department of Transport  
 Federation of Civil Engineering Contractors  
 Institution of Civil Engineers  
 Institution of Structural Engineers  
 National Council of Building Material Producers  
 Royal Institute of British Architects  
 Timber Research and Development Association

The following bodies were also represented in the drafting of the standard, through subcommittees and panels:

British Industrial Fasteners Federation  
 British Steel Industry  
 Concrete Society  
 Department of the Environment (Specialist Services)  
 Society of Engineers Incorporated  
 Steel Construction Institute

This British Standard, having been prepared under the direction of Technical Committee B/525, was published under the authority of the Standards Board and comes into effect on 15 January 1994

© BSI 12-1998

First published December 1982  
 Second edition January 1994

The following BSI references relate to the work on this standard:  
 Committee reference B/525/4  
 Draft for comment 86/16901 DC

ISBN 0 580 21808 2

## Amendments issued since publication

Amd. No.	Date	Comments

# Contents

	Page
Committees responsible	Inside front cover
Foreword	iii
<hr/>	
Section 1. General	
1.0 Introduction	1
1.1 Scope	1
1.2 References	1
1.3 Definitions	1
1.4 Symbols	2
<hr/>	
Section 2. Limit state design	
2.1 General principles	3
2.2 Loading	3
2.3 Design methods	4
2.4 Ultimate limit states	5
2.5 Serviceability limit states	5
2.6 Durability	5
<hr/>	
Section 3. Materials	
3.1 Profiled steel sheets	6
3.2 Steel reinforcement	6
3.3 Concrete	6
3.4 Shear connectors	8
3.5 Sheet fixings	8
<hr/>	
Section 4. Design: general recommendations	
4.1 Form of construction	9
4.2 Design stages	10
4.3 Temporary supports	10
4.4 Provision of reinforcement	10
4.5 Cover to reinforcement	10
4.6 Methods of developing composite action	12
4.7 Minimum bearing requirements	13
4.8 Constructional details	13
<hr/>	
Section 5. Design: profiled steel sheeting	
5.1 General	15
5.2 Load carrying capacity	15
5.3 Deflection of profiled steel sheeting	15
<hr/>	
Section 6. Design: composite slab	
6.1 General	16
6.2 Strength	16
6.3 Moment capacity	16
6.4 Shear capacity	18
6.5 Vertical shear and punching shear	20
6.6 Deflection of the composite slab	20
6.7 Concentrated loads	22
6.8 Nominal reinforcement at intermediate supports	22
6.9 Transverse reinforcement	23
6.10 Shear connection	23

	Page
Section 7. Fire resistance	
7.1 General	24
7.2 Minimum thickness of concrete	24
7.3 Determination of fire resistance	24
<hr/>	
Section 8. Testing of composite slabs	
8.1 General	25
8.2 Specific tests	26
8.3 Parametric tests	27
<hr/>	
Figure 1 — Arrangement of construction loads	3
Figure 2 — Sheet and slab dimensions	7
Figure 3 — Typical composite slab	9
Figure 4 — Typical profiles	11
Figure 5 — Bearing requirements	12
Figure 6 — Modes of failure of a composite slab	17
Figure 7 — Stress blocks for moment capacity	18
Figure 8 — Shear spans	19
Figure 9 — Critical perimeter for shear	21
Figure 10 — Distribution of concentrated load	23
Figure 11 — Test details	25
Figure 12 — Shear-bond failure	28
<hr/>	
Table 1 — Values of $\gamma_f$ for ultimate limit states	4
Table 2 — Span-to-depth ratios	22
<hr/>	
List of references	Inside back cover
<hr/>	

## Foreword

This Part of BS 5950 has been prepared under the direction of Technical Committee B/525, Building and civil engineering structures. BS 5950 comprises codes of practice which cover the design, construction and fire protection of steel structures and specifications for materials, workmanship and erection.

It comprises the following Parts and Sections:

- *Part 1: Code of practice for design in simple and continuous construction: hot rolled sections;*
- *Part 2: Specification for materials, fabrication and erection: hot rolled sections;*
- *Part 3: Design in composite construction;*
- *Section 3.1: Code of practice for design of simple and continuous composite beams;*
- *Part 4: Code of practice for design of composite slabs with profiled steel sheeting;*
- *Part 5: Code of practice for design of cold formed sections;*
- *Part 6<sup>1)</sup>: Code of practice for design of light gauge profiled sheeting;*
- *Part 7: Specification for materials and workmanship: cold formed sections;*
- *Part 8: Code of practice for fire resistant design;*
- *Part 9: Code of practice for stressed skin design.*

This Part of BS 5950 gives recommendations for the design of composite slabs in which profiled steel sheeting acts compositely with concrete or acts only as permanent formwork.

This British Standard supersedes BS 5950-4:1982, which is withdrawn.

BS 5950-4:1982 was the first Part of BS 5950 to be issued. Most of the other Parts have since been issued or are expected to be published shortly. In addition BS 8110 has superseded CP 110. It was therefore necessary to update the cross-references in this document, add material related to composite beams and align the values of the partial safety factors for loads with those now recommended in BS 5950-1. A number of minor amendments have also been made as a result of experience in the use of the code.

The work on BS 5950-3 led to a survey of construction loads, which was also relevant to the recommendations of this Part and enabled the partial safety factors for these loads to be rationalized. In addition it had become apparent in the drafting of BS 5950-3 that some adjustments to terminology (such as “composite slab”) would be beneficial for clarity and some symbols needed additional subscripts to maintain compatibility with both BS 5950-3 and BS 5950-1. This revised terminology led to the modified title of Part 4.

A few further improvements have been made. These include recommendations on span-to-depth ratios and on end anchorage. The density of lightweight concrete covered has also been aligned with that in BS 5950-3.1.

The clauses on the design of profiled sheets have been replaced by cross-references to BS 5950-6<sup>1)</sup>, rather than updated to align with Part 6. The need to adjust the clause numbers to allow for the various additions and omissions, has provided the opportunity to restructure the document in a manner compatible with that now used in the other Parts of BS 5950, with the type of clause numbering system now used in the other Parts of BS 5950.

<sup>1)</sup> In preparation.

Apart from the above changes, the technical content of the standard is unchanged.

It has been assumed in the drafting of this British Standard that the execution of its provisions is entrusted to appropriately qualified and experienced people, and that construction and supervision are carried out by capable and experienced organizations.

A British Standard does not purport to include all the necessary provisions of a contract. Users of British Standards are responsible for their correct application.

**Compliance with a British Standard does not of itself confer immunity from legal obligations.**

#### **Summary of pages**

This document comprises a front cover, an inside front cover, pages i to iv, pages 1 to 30, an inside back cover and a back cover.

This standard has been updated (see copyright date) and may have had amendments incorporated. This will be indicated in the amendment table on the inside front cover.

# Section 1. General

## 1.0 Introduction

### 1.0.1 Aims of economical structural design

The aim of structural design of a composite slab is to provide, with due regard to economy, a slab capable of fulfilling its intended function and sustaining the specified loads for its intended life. The design should facilitate construction, both of the slab itself and of the structure of which it forms part.

The composite slab should be sufficiently robust and insensitive to the effects of minor incidental loads applied during service that the safety of other parts of the structure is not prejudiced.

Although the ultimate strength recommendations within this standard are to be regarded as limiting values, the purpose in design should be to reach these limits at as many places as possible, consistent with economy, in order to obtain the optimum combination of material and construction costs.

### 1.0.2 Overall stability

The designer responsible for the overall stability of the structure should ensure compatibility of structural design and detailing between all those structural parts and components which are required for overall stability, even when some or all of the structural design and detailing of those parts and components is carried out by another designer.

### 1.0.3 Accuracy of calculation

For the purpose of deciding whether a particular recommendation is satisfied, the final value, observed or calculated, expressing the result of a test or analysis should be rounded off. The number of significant places retained in the rounded off value should be the same as in the value given in the recommendation.

## 1.1 Scope

This Part of BS 5950 gives recommendations for the design of composite slabs with profiled steel sheeting. It covers slabs spanning only in the direction of span of the profiled steel sheets.

This code applies to the design of composite slabs in buildings. It does not apply to highway or railway bridges, for which reference should be made to BS 5400-5.

For the design of composite steel beams with a composite slab as the concrete flange, reference should be made to BS 5950-3.1.

Diaphragm action produced by the capacity of the composite slab (or of the profiled steel sheets at the construction stage) to resist distortion in its own plane is not within the scope of this Part of BS 5950.

For the design of profiled steel sheeting as a stressed skin diaphragm, reference should be made to BS 5950-9.

## 1.2 References

### 1.2.1 Normative references

This Part of BS 5950 incorporates, by reference, provisions from specific editions of other publications. These normative references are cited at the appropriate points in the text and the publications are listed on the inside back cover. Subsequent amendment to, or revisions of, any of these publications apply to this Part of BS 5950 only when incorporated in it by amendment or revision.

### 1.2.2 Informative references

This Part of BS 5950 refers to other publications that provide information or guidance. Editions of these publications current at the time of issue of this standard are listed on the inside back cover, but reference should be made to the latest editions.

## 1.3 Definitions

For the purposes of this Part of BS 5950, the following definitions apply.

### 1.3.1

#### composite slab

a slab consisting of profiled steel sheets and a concrete slab, with steel reinforcement where necessary

### 1.3.2

#### composite action

the structural interaction which occurs when the components of a composite slab interact to form a single structural element

### 1.3.3

#### permanent shuttering

profiled steel sheeting designed to support wet concrete, reinforcement and construction loads

### 1.3.4

#### negative moment

bending moment causing compression at the bottom of the slab

### 1.3.5

#### positive moment

bending moment causing tension at the bottom of the slab

### 1.3.6

#### longitudinal reinforcement

reinforcement of a composite slab, running parallel to the corrugations of the profiled steel sheets



### 1.3.7 transverse reinforcement

reinforcement of a composite slab, running perpendicular to the corrugations of the profiled steel sheets

## 1.4 Symbols

$a$	Distance from a concentrated load to the nearer support	$L_v$	Shear span of composite slab
$A_p$	Cross-sectional area of profiled steel sheeting	$N$	Number of shear connectors attached to the end of each span of sheets, per unit length of supporting beam
$B_s$	Width of composite slab	$m_r$	Empirical parameter (slope of reduction line from parametric tests)
$b_a$	Mean width of trough (open sheet profile)	$P_a$	End anchorage capacity per shear connector
$b_b$	Minimum width of trough (sheet profile)	$P_b$	Capacity per shear connector for composite beam design
$b_{eb}$	Effective width of slab (bending)	$p_{yp}$	Design strength of profiled steel sheets
$b_{er}$	Effective width of slab (shear)	$Q_k$	Characteristic resistance per shear connector
$b_m$	Effective load width	$R_{e.min}$	Specified yield strength of profiled steel sheets
$b_o$	Width of concentrated load	$t_f$	Thickness of finishes above concrete slab
$D_p$	Overall depth of profiled steel sheets	$u$	Critical perimeter for punching shear
$D_s$	Overall depth of composite slab	$\bar{V}_a$	Shear capacity per unit width of composite slab due to the end anchorage provided by the shear connectors
$d_s$	Effective depth of slab to centroid of profiled steel sheets	$\bar{V}_c$	Total longitudinal shear capacity per unit width of composite slab
$E$	Modulus of elasticity of profiled steel sheets	$V_E$	Maximum experimental shear force
$F_a$	End anchorage force per shear connector	$V_P$	Punching shear capacity of composite slab
$F_b$	Beam longitudinal shear force per shear connector	$V_s$	Shear-bond capacity of composite slab
$f_{cm}$	Concrete cube strength (observed value)	$\bar{V}_s$	Shear-bond capacity of composite slab per unit width
$f_{cu}$	Characteristic concrete cube strength	$V_v$	Vertical shear capacity of composite slab
$h_{agg}$	Nominal maximum size of aggregate	$v_c$	Design concrete shear stress
$I_{CA}$	Second moment of area of the composite slab about its centroidal axis (in equivalent steel units)	$W_c$	Applied load capacity of composite slab
$k_r$	Empirical parameter (intercept of reduction line from parametric tests)	$W_f$	Reaction or concentrated load
$L_p$	Effective span of profiled steel sheets, which is the smaller of: a) distance between centres of permanent or temporary supports, and b) clear span between permanent or temporary supports plus overall depth of profiled sheets $D_p$	$W_{ser}$	Serviceability load
$L_s$	Effective span of composite slab, which is the smaller of: a) distance between centres of permanent supports, and b) clear span between permanent supports plus effective depth of composite slab $d_s$	$W_{st}$	Failure load
		$W_w$	Anticipated value of the applied load
		$x_c$	Depth of concrete in compression at midspan
		$z$	Lever arm
		$\gamma_f$	Partial safety factor for loads
		$\gamma_m$	Partial safety factor for resistances
		$\delta$	Deflection

## Section 2. Limit state design

### 2.1 General principles

Composite slabs should be designed by considering the limit states at which they would become unfit for their intended use. Appropriate safety factors should be applied for the ultimate limit state and the serviceability limit state.

All limit states covered in BS 5950-1:1990 or in BS 8110-1:1985 should be considered.

The recommendations given in this Part of BS 5950 should be followed for the ultimate limit states of strength and stability and for the serviceability limit state of deflection.

### 2.2 Loading

#### 2.2.1 General

All relevant loads should be considered separately and in such realistic combinations as to cause the most critical effects on the components and on the composite slab as a whole.

Loading conditions during construction should also be considered (see 2.2.3).

#### 2.2.2 Dead, imposed and wind loading

Reference should be made to BS 6399-1:1984, BS 6399-3:1988 and CP 3:Chapter V-2:1972 for the determination of the dead, imposed and wind loads.

The weight of the finished slab should be increased if necessary to allow for the additional concrete placed as a result of the deflection of the profiled steel sheeting (see 5.3).

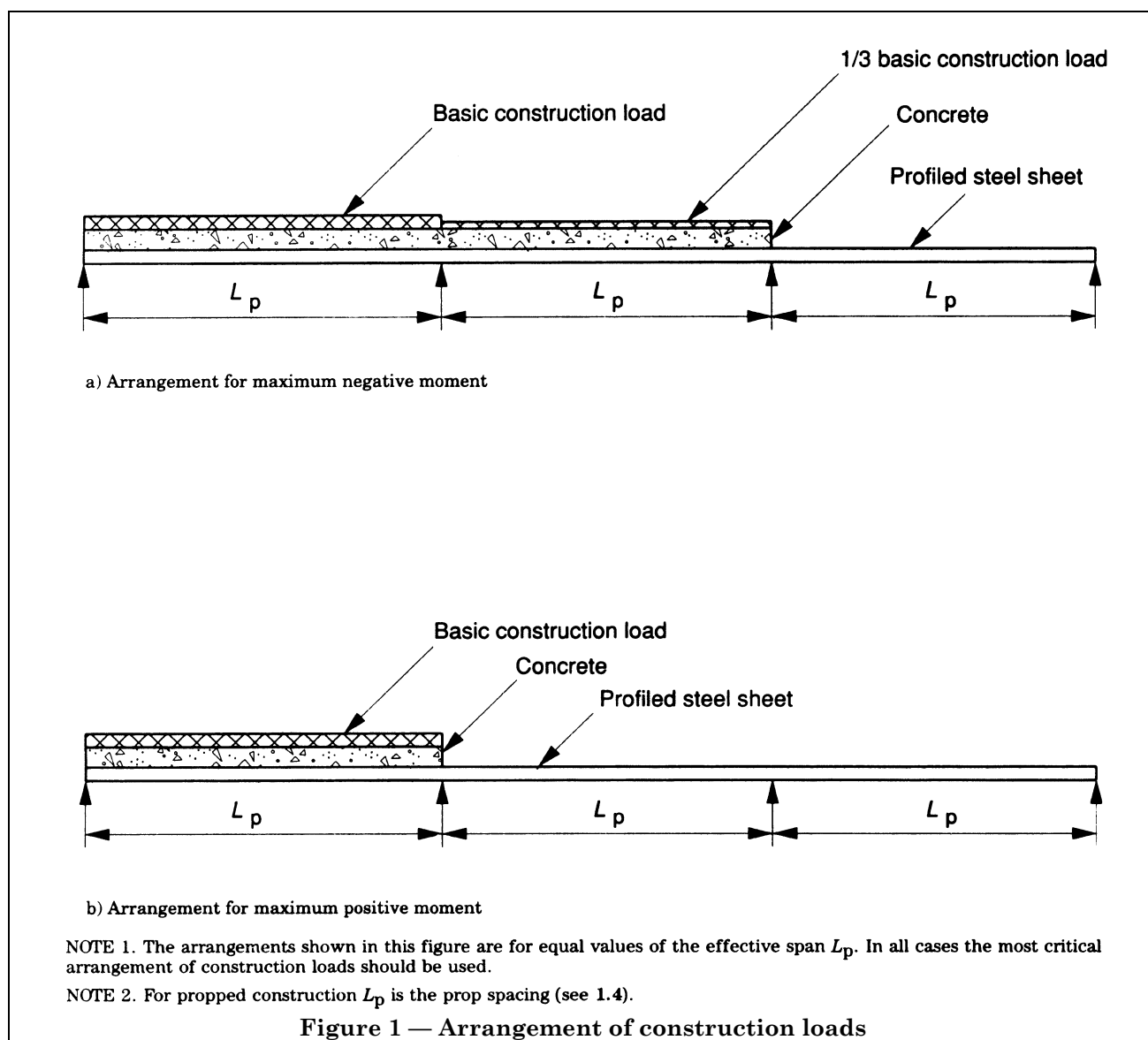

## 2.2.3 Construction loads

### 2.2.3.1 Basic construction loads

Construction loads should be considered in addition to the weight of the wet concrete slab.

In general purpose working areas the basic construction load on one span of the sheeting should be taken as not less than  $1.5 \text{ kN/m}^2$ . The other spans should be taken as either loaded with the weight of the wet concrete slab plus a construction load of one-third of the basic construction load, or unloaded apart from the self-weight of the profiled steel sheets, whichever is the more critical for the positive and negative moments in the sheeting (see Figure 1).

For spans of less than 3 m, the basic construction load should be increased to not less than  $4.5/L_p \text{ kN/m}^2$ , where  $L_p$  is the effective span of the profiled steel sheets in metres.

Allowance is made within these values for construction operatives, impact and heaping of concrete during placing, hand tools, small items of equipment and materials for immediate use. The minimum values quoted are intended for use in general purpose working areas, but will not necessarily be sufficient for excessive impact or heaping of concrete, or pipeline or pumping loads. Where excessive loads are expected, reference should be made to BS 5975:1982.

Reference should also be made to 5.3 for possible increased loading due to ponding at the construction stage.

### 2.2.3.2 Storage loads

Where materials to be stored temporarily on erected sheeting (or on a recently formed slab before it is self-supporting) produce equivalent distributed loads in excess of the basic construction loads, provision should be made in the design for the additional temporary storage loads.

### 2.2.4 Accidental loads

Accidental loads should be treated as recommended in BS 5950-1.

## 2.3 Design methods

### 2.3.1 General

The following methods may be used for the design of composite slabs:

- composite design in which the concrete and the profiled steel sheets are assumed to combine structurally to support loads (see section 6);
- design as a reinforced concrete slab as recommended in BS 8110-1:1985, neglecting any contribution from the profiled steel sheets;
- design by specific testing (see 2.3.2.1).

In all cases the profiled steel sheeting should be designed for use as permanent shuttering during construction (see section 5).

**Table 1 — Values of  $\gamma_f$  for ultimate limit states**

Combination	Type of load	$\gamma_f$
Dead and imposed load	Dead load (see note)	{ Maximum 1.4 Minimum 1.0
	Imposed load	1.6
Dead and wind load	Dead load (see note)	{ Maximum 1.4 Minimum 1.0
	Imposed load	1.4
Dead, imposed and wind load	Dead load (see note)	{ Maximum 1.2 Minimum 1.0
	Imposed load	1.2
	Wind load	1.2
Construction stage (temporary erection condition)	Dead load of wet concrete (see note)	{ Maximum 1.4 Minimum 0.0
	Construction loads (see 2.2.3)	1.6
NOTE For dead loads, the minimum $\gamma_f$ factor should be used for dead loads that counteract the effects of other loads causing overturning or uplift.		

### 2.3.2 Testing

#### 2.3.2.1 Specific tests

Where testing is used as an alternative to calculation methods of design, the load carrying capacity of a composite slab may be determined directly from the results of specific tests as recommended in 8.2.

#### 2.3.2.2 Parametric tests

In the calculation method for composite design given in section 6, the shear-bond capacity should be determined using the empirical parameters obtained from the results of parametric tests as recommended in 8.3.

## 2.4 Ultimate limit states

### 2.4.1 Limit state of strength

In checking the strength of a composite slab, the loads should be multiplied by the appropriate value of the partial safety factor for loads  $\gamma_f$  given in Table 1. The factored loads should be applied in the most unfavourable realistic combination for the part or effect under consideration.

### 2.4.2 Stability against overturning

The factored loads, considered separately and in combination, should not cause the composite slab (or the profiled steel sheeting at the construction stage) to overturn, slip or lift off its seating. The combination of dead, imposed (or construction) and wind loads should be such as to have the most severe effect.

### 2.4.3 Strength of materials

In the design of the profiled steel sheeting before composite action with the concrete slab is developed, the design strength of the profiled steel sheets should be taken as specified in BS 5950-6<sup>2)</sup>.

For the design of the composite slab, the design strength  $p_{yp}$  of the profiled steel sheets should be taken as 0.93 times the specified yield strength  $R_{e,min}$  (see 3.1.1), or 0.93 times the characteristic strength for the grade of steel used.

NOTE The value 0.93 represents  $1/\gamma_m$ , where  $\gamma_m$  is a partial safety factor allowing for tolerances.

The modulus of elasticity  $E$  of profiled steel sheets should be taken as 210 kN/mm<sup>2</sup>.

The properties of concrete and reinforcement to be used in design should follow the recommendations of BS 8110.

## 2.5 Serviceability limit states

### 2.5.1 Serviceability loads

Generally, the serviceability loads should be taken as the unfactored values (i.e.  $\gamma_f = 1.0$ ). When considering dead load plus imposed load plus wind load, only 80 % of the imposed load and wind load need be considered.

Construction loads should not be included in the serviceability loads.

### 2.5.2 Deflections

Deflections under serviceability loads should not impair the strength or efficiency of the structure or cause damage to the finishings.

The recommendations given in 5.3 should be followed for profiled steel sheeting at the construction stage and those given in 6.6 should be followed for the deflection of the composite slab.

## 2.6 Durability

### 2.6.1 Corrosion protection of profiled steel sheets

The exposed surface at the underside of the profiled steel sheets should be adequately protected to resist the relevant environmental conditions, including those arising during site storage and erection. Reference should be made to BS 5493:1977 for the recommended protective systems. Any damage to zinc coating or other surface protection should be made good.

NOTE 1 Due to the possibility of corrosion caused by road de-icing salts or sea salt, composite slabs with zinc coated profiled steel sheeting may not be appropriate for use without special measures in car park structures, or in the vicinity of seawater or seawater spray.

NOTE 2 Dilute acids from process industries (which are sometimes airborne) may corrode galvanized surfaces.

### 2.6.2 Concrete durability

For the durability of the concrete in the composite slab, the relevant recommendations in BS 8110 should be followed.

### 2.6.3 Fire resistance

The recommendations in section 7 should be followed.

<sup>2)</sup> In preparation.

## Section 3. Materials

### 3.1 Profiled steel sheets

#### 3.1.1 Specification

The steel used to manufacture the profiled steel sheets should have a specified yield strength  $R_{e,min}$  of not less than 220 N/mm<sup>2</sup> and should generally be in accordance either with BS 2989:1992 or with BS EN 10147:1992. Steels conforming to other specifications may alternatively be used provided that they have similar properties.

#### 3.1.2 Sheet thickness

The structural thickness of the profiled steel sheets, to which the stresses and section properties apply, should be taken as the “bare metal thickness” of the sheets excluding any protective or decorative finish such as zinc coating or organic coating.

The nominal bare metal thickness of the sheets should not normally be less than 0.75 mm except where the profiled steel sheets are used only as permanent shuttering (see 4.1). Thinner sheets should not be used unless adequate theoretical evidence and test data are available to justify their use.

#### 3.1.3 Zinc coating

The zinc coating should conform to the requirements of BS 2989:1992 or BS EN 10147:1992 as appropriate. A coating of 275 g/m<sup>2</sup> total, including both sides (coating type G 275 in accordance with BS 2989) is normally specified for internal floors in a non-aggressive environment, but the specification may be varied depending on service conditions.

NOTE A 275 g/m<sup>2</sup> coating adds approximately 0.04 mm to the bare metal thickness, 0.02 mm on each side. The nominal bare metal thickness is thus 0.04 mm less than the nominal thickness of the sheet.

Before a zinc coating heavier than 275 g/m<sup>2</sup> is specified, confirmation should be obtained from the proposed manufacturer of the profiled steel sheets that the proposed coating thickness is compatible with the forming operations involved.

All zinc coatings should be chemically passivated with a chromate treatment to minimize wet storage stains (white rusting) and reduce chemical reaction at the concrete/zinc interface.

### 3.2 Steel reinforcement

#### 3.2.1 Specification

The type of reinforcement used should satisfy the recommendations of BS 8110 and should conform to BS 4449:1988, BS 4482:1985 or BS 4483:1985, subject to the recommendations in 3.2.2.

#### 3.2.2 Ductility of reinforcement

Wherever account is taken in design of the efficiency of continuity over a support, to ensure that the reinforcement has adequate ductility the steel fabric or reinforcing bars used as support reinforcement should satisfy the minimum elongation requirement specified in 10.1.2 of BS 4449:1988.

This recommendation should be applied to the following:

- a) reinforcement used to resist negative moments in continuous spans or cantilevers;
- b) distribution steel for concentrated loads or around openings in the slab;
- c) reinforcement used to increase the fire resistance of the composite slab.

However it need not be applied to the following:

- 1) secondary transverse reinforcement;
- 2) nominal continuity reinforcement over supports;
- 3) tensile reinforcement in the span.

### 3.3 Concrete

#### 3.3.1 General

Concrete should follow the recommendations given in BS 8110.

#### 3.3.2 Lightweight concrete

The dry density of lightweight aggregate structural concrete should normally be not less than 1 750 kg/m<sup>3</sup>.

Other densities can be used, but all references to lightweight concrete elsewhere in this Part of BS 5950 assume a dry density of at least 1 750 kg/m<sup>3</sup>. Where lightweight concrete of less than 1 750 kg/m<sup>3</sup> dry density is used, due allowance should be made for variations in properties of concrete and their effect on the resistances of shear connectors.

#### 3.3.3 Density

In the absence of more precise information, the nominal density should be taken as follows.

- a) For design of the profiled steel sheeting (wet density):
  - 2 400 kg/m<sup>3</sup> for normal weight concrete;
  - 1 900 kg/m<sup>3</sup> for lightweight concrete.
- b) For design of the composite slab (dry density):
  - 2 350 kg/m<sup>3</sup> for normal weight concrete;
  - 1 800 kg/m<sup>3</sup> for lightweight concrete.

NOTE For lightweight concrete the density may be found in manufacturers' literature.

### 3.3.4 Aggregate size

The nominal maximum size of the aggregate  $h_{agg}$  depends on the smallest dimension in the structural element within which concrete is poured and should be not greater than the least of:

- $0.4 (D_s - D_p)$  (see Figure 2);
- $b_b/3$  (see Figure 2);
- 20 mm.

### 3.3.5 Slab thickness

The overall depth of the composite slab  $D_s$  should be sufficient to provide the required resistance to the effects of fire (see 7.2) and as a minimum should not be less than 90 mm. The thickness of concrete ( $D_s - D_p$ ) above the main flat surface of the top of the ribs of the profiled steel sheets should be not less than 50 mm subject to cover of not less than 15 mm above the top of any shear connectors.

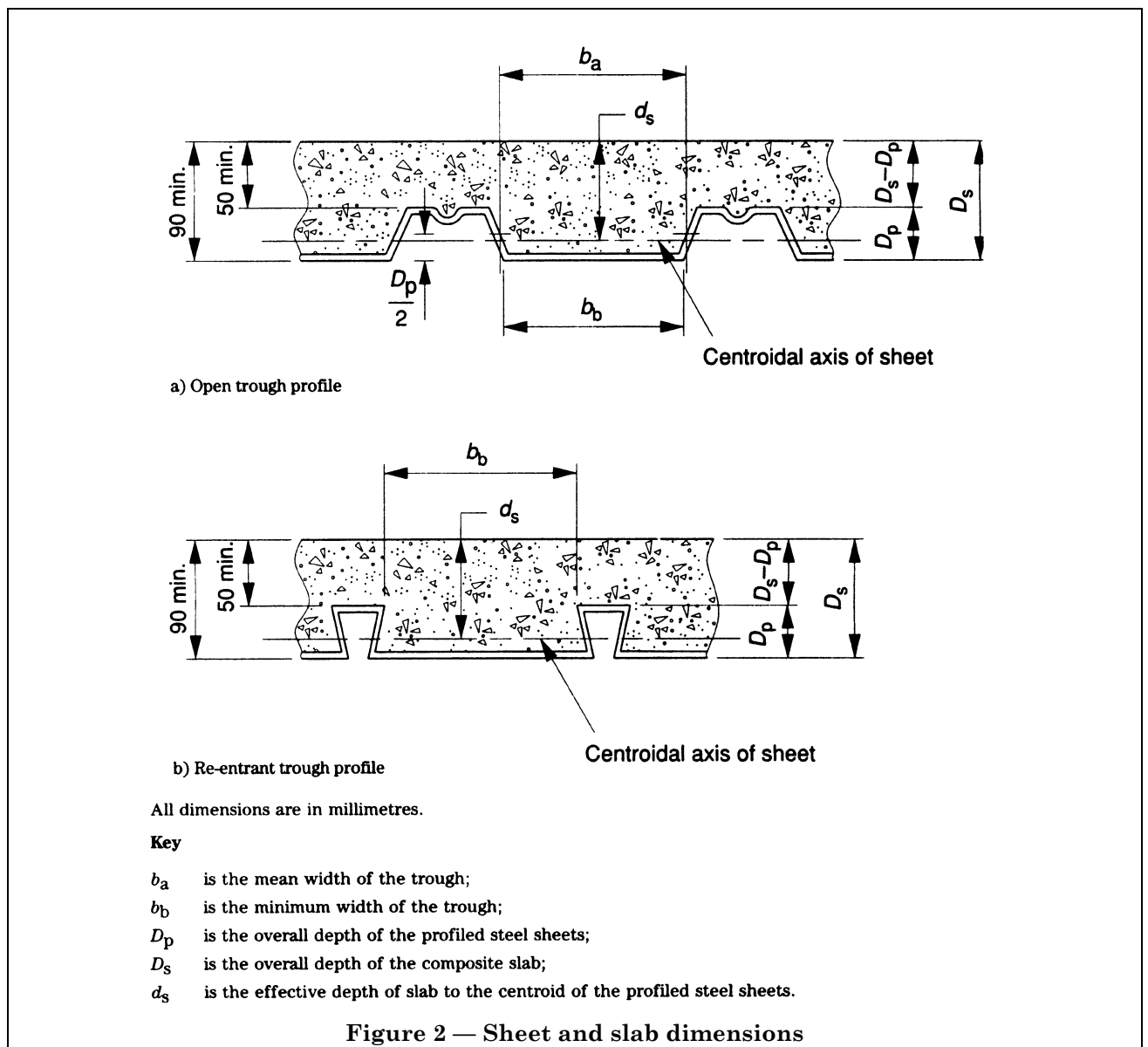

### 3.3.6 Admixtures

Admixtures may be used following the recommendations of BS 8110, provided that the zinc coating of the profiled sheets is not adversely affected. The profiled steel sheets should be considered as “embedded metal” when applying the recommendations of BS 8110.

## 3.4 Shear connectors

### 3.4.1 General

Shear connectors should satisfy the recommendations of BS 5950-3.1:1990. Resistances of shear connectors other than those given in BS 5950-3.1:1990 should be determined on the basis of push-out tests.

### 3.4.2 Stud shear connectors

The influence of the density of concrete on the design value of stud shear connectors should be allowed for. The characteristic resistances of stud shear connectors in lightweight aggregate concrete of dry density not less than  $1\,750\text{ kg/m}^3$  should be taken as 90 % of the values in normal weight concrete, as recommended in BS 5950-3.1:1990.

## 3.5 Sheet fixings

Screws and other mechanical fasteners used to fix the profiled steel sheets to the beams or other supports, and fasteners used at side laps of sheets, should be in accordance with BS 5950-6<sup>3)</sup>.

---

<sup>3)</sup> In preparation.

## Section 4. Design: general recommendations

### 4.1 Form of construction

Composite slabs (see Figure 3), should consist of in-situ concrete placed on profiled steel sheets, designed to act as permanent shuttering for the wet concrete, so that as the concrete hardens it will combine structurally with the profiled steel sheets to form a composite element.

Composite action should be obtained in one of the following ways:

- a) by mechanical interlock;
- b) by friction induced by the profile shape;
- c) by end anchorages;
- d) by a combination of c) with either a) or b).

Any bonding or adhesion of a chemical nature should be neglected in design.

Steel reinforcement should be provided where necessary (see 4.4). However, steel reinforcement should not be used to resist positive moments in combination with profiled steel sheets, unless the moment capacity has been determined by testing (see 6.3).

Alternatively the profiled steel sheeting should be designed to act only as permanent shuttering. In this case tensile reinforcement should be provided in the span and the slab should be designed as reinforced concrete as recommended in BS 8110, without relying on composite action with the profiled sheets.

NOTE 1 In practice, this alternative type of slab often provides some degree of composite action, and it is difficult to prevent it from doing so. The action so produced does not prejudice its structural efficiency, because removal of the steel shuttering (if this could be done without any damage to the concrete) would not significantly reduce the strength of the slab or its fire resistance. The profiled steel sheets are left in place, but any beneficial effect they may have is neglected in design.

Where service ducts are formed in the slab, due allowance should be made for the resulting reduction in load carrying capacity (see 6.1.3).

NOTE 2 The reduction in load carrying capacity is particularly severe in the case of ducts running transverse to the span of the slab.

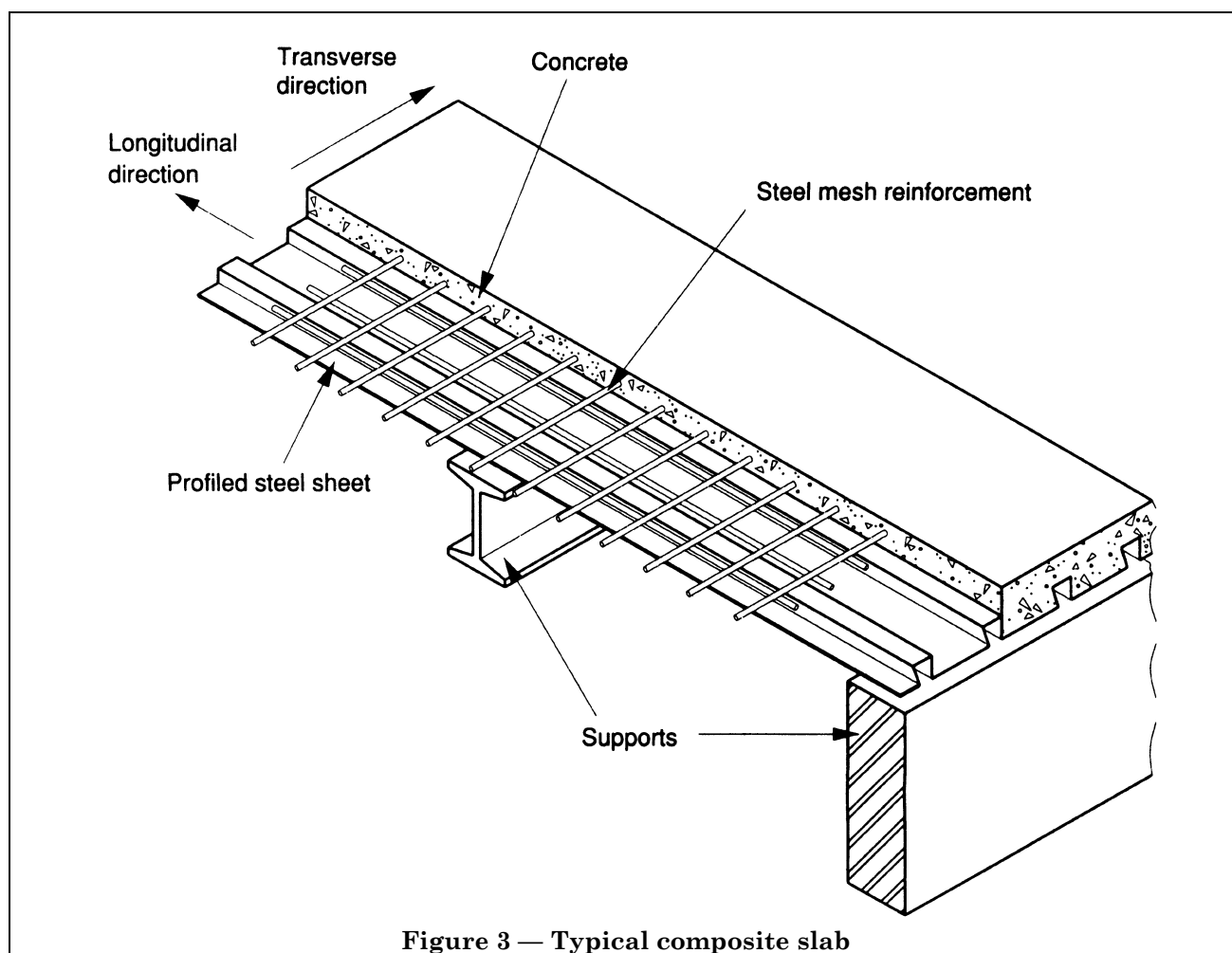

Figure 3 — Typical composite slab



## 4.2 Design stages

The following stages should be considered in the design of composite slabs.

- a) *Stage 1. Profiled steel sheeting as formwork.*  
The assessment of commercially available shapes of profiled steel sheets, used as formwork to support wet concrete. This includes checking the load carrying capacity, the deflection and the effects of using props (see section 5).
- b) *Stage 2. Composite slab.* Composite action between the profiled steel sheets and the structural concrete slab. This includes checking the load carrying capacity and the deflection (see section 6).

## 4.3 Temporary supports

Normally unpropped construction should be used. However, where safe span limits for construction would otherwise be exceeded, temporary supports should be provided to the profiled steel sheeting until the concrete has reached an adequate strength, in order to avoid exceeding the capacity of the profiled steel sheets under the loading of wet concrete and construction loads. Propped construction should also be used to reduce the deflection of the profiled steel sheeting, where the deflection limits would otherwise be exceeded.

Where temporary supports are used, the effects of their use and subsequent removal on the distribution of shear forces in the composite slab should be allowed for in the design of both the supporting and the supported slabs.

**NOTE** It is essential that temporary supports should be used only where specified in the design documents or drawings.

The method of providing temporary supports should be chosen to suit the conditions on site. Normally, one of the following should be used:

- a) temporary props from beneath;
- b) temporary beams at the soffit of the sheets.

Alternative methods may be used where suitable but, in all cases, the temporary support should be capable of carrying all the loads and forces imposed on it without undue deflection.

Where isolated temporary supports are used, a spreader beam should be incorporated in order to provide a continuous support to the profiled steel sheets. Unless otherwise specified in the design documents or drawings, this should be parallel to the permanent supports.

Regardless of the method of support used, the arrangement should be such that the soffit of the sheet is not cambered above a line joining the level of the permanent supports by a distance greater than  $L_s/350$ , where  $L_s$  is the effective span of the composite slab.

Any slab used to support temporary props should be checked for adequate resistance to the forces applied by the props, or during the removal of the props, using the appropriate concrete strength for the age of that slab.

## 4.4 Provision of reinforcement

Steel reinforcement, in the form of either bars or steel mesh fabric, should be provided in composite slabs as follows:

- a) nominal continuity reinforcement over intermediate supports, for simple spans;
- b) full continuity reinforcement over intermediate supports, for continuous spans and for cantilevers;
- c) distribution steel, where concentrated loads are applied and around openings;
- d) secondary transverse reinforcement to resist shrinkage and temperature stresses.

Where necessary, steel reinforcement should also be provided as follows:

- 1) to increase the fire resistance of the composite slab;
- 2) as tensile reinforcement in the span.

## 4.5 Cover to reinforcement

Steel reinforcement in a slab in the form of bars or steel mesh fabric should be positioned as follows.

- a) Longitudinal reinforcement in the bottom of the slab should be so positioned that sufficient space, not less than the nominal maximum size of the aggregate, is left between the reinforcement and the sheets to ensure proper compaction of the concrete.
- b) Transverse reinforcement in the bottom of the slab should be placed directly on the top of the ribs of the sheets.
- c) Distribution steel in areas of concentrated loads and around openings should be placed directly on the top of the ribs of the sheets, or not more than a nominal 25 mm above it.
- d) Fire resistance reinforcement intended to provide positive moment capacity should be placed in the bottom of the slab with not less than 25 mm between the reinforcement and the bottom of the sheets.

- e) Reinforcement in the top of the slab should have 25 mm<sup>4)</sup> nominal cover.
- f) Fire resistance reinforcement for negative moment capacity should be placed in the top of the slab with 25 mm<sup>4)</sup> nominal cover.
- g) Secondary transverse reinforcement for controlling shrinkage should be placed in the top of the slab with 25 mm<sup>4)</sup> nominal cover.

The curtailment and lapping of reinforcement should conform to BS 8110. Where a single layer of reinforcement is used to fulfil more than one of the above purposes, it should satisfy all the relevant recommendations.

NOTE Longitudinal and transverse are used here as defined in 1.3 to describe slab reinforcement. Where a composite slab forms the concrete flange of a composite beam, BS 5950-3.1 gives recommendations for transverse reinforcement of the beam, running perpendicular to the span of the beam. Such reinforcement can be either longitudinal or transverse relative to the slab.

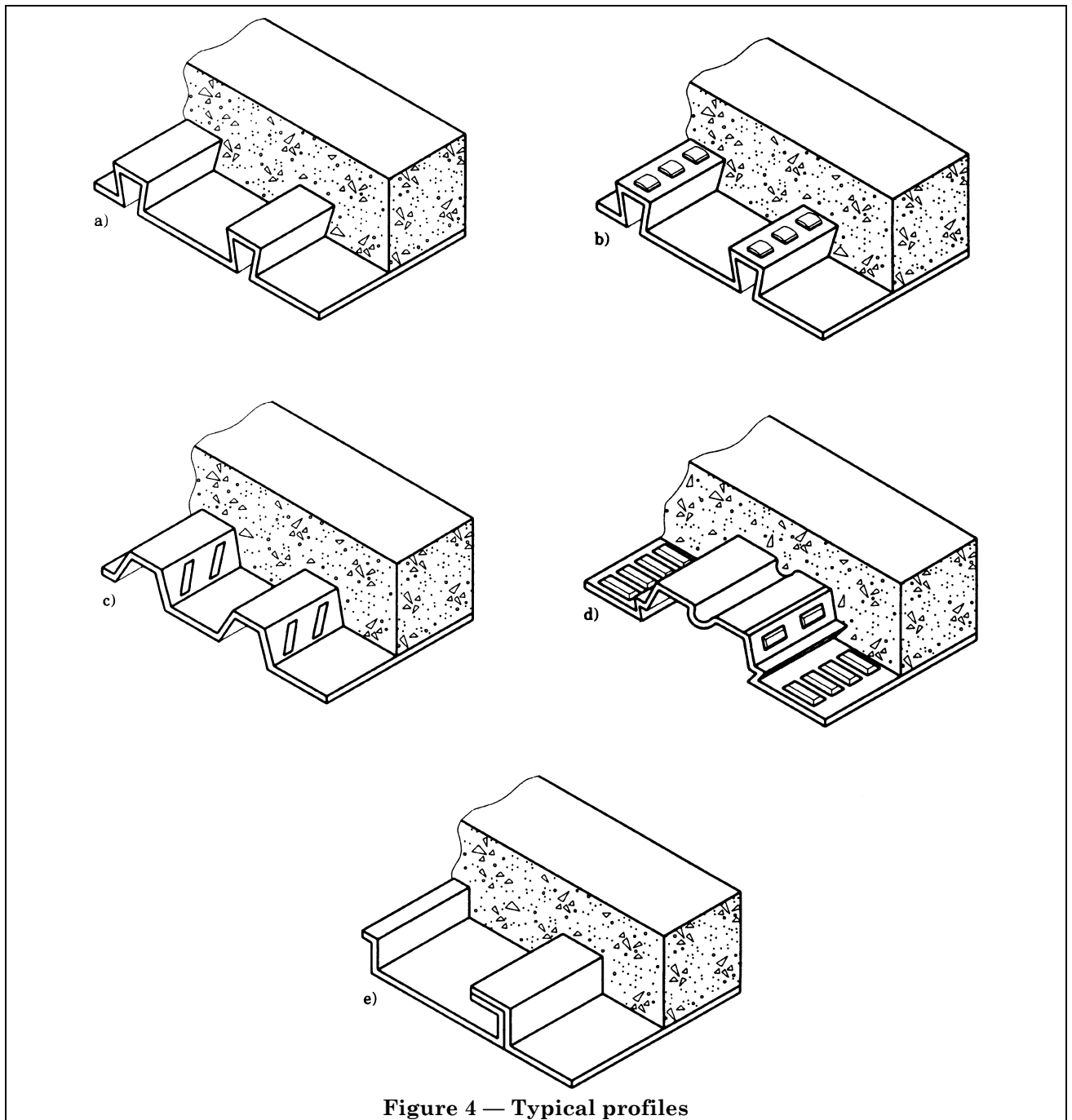

Figure 4 — Typical profiles

<sup>4)</sup> The nominal cover of 25 mm is common practice, but in appropriate cases this may be reduced to values in accordance with Tables 3.4 and 3.5 of BS 8110-1:1985 or Tables 5.1 and 5.2 of BS 8110-2:1985.

## 4.6 Methods of developing composite action

### 4.6.1 General

The shear connection needed for composite action should be developed either by shear bond between the concrete and the profiled steel sheets or else by end anchorage, or by a combination of both methods (see 4.6.6).

For shear bond, the profiled steel sheets should be capable of transmitting horizontal shear at the interface between the sheet and the concrete. This should be achieved by one or more of the methods given in 4.6.3 to 4.6.5 or by any other proven method. In all cases the shear-bond capacity should be determined by testing (see section 8).

### 4.6.2 Plain open profiled sheets

Plain open profiled sheets should not be used where composite action is required, unless accompanied by some means of shear connection (see 4.6.5 and 4.6.6).

### 4.6.3 Plain re-entrant angle profiled sheets

Plain re-entrant angle profiled sheets, as illustrated in Figure 4 a), should be designed to provide shear connection between the sheets and the concrete by means of the interlocking effect of the re-entrant shape.

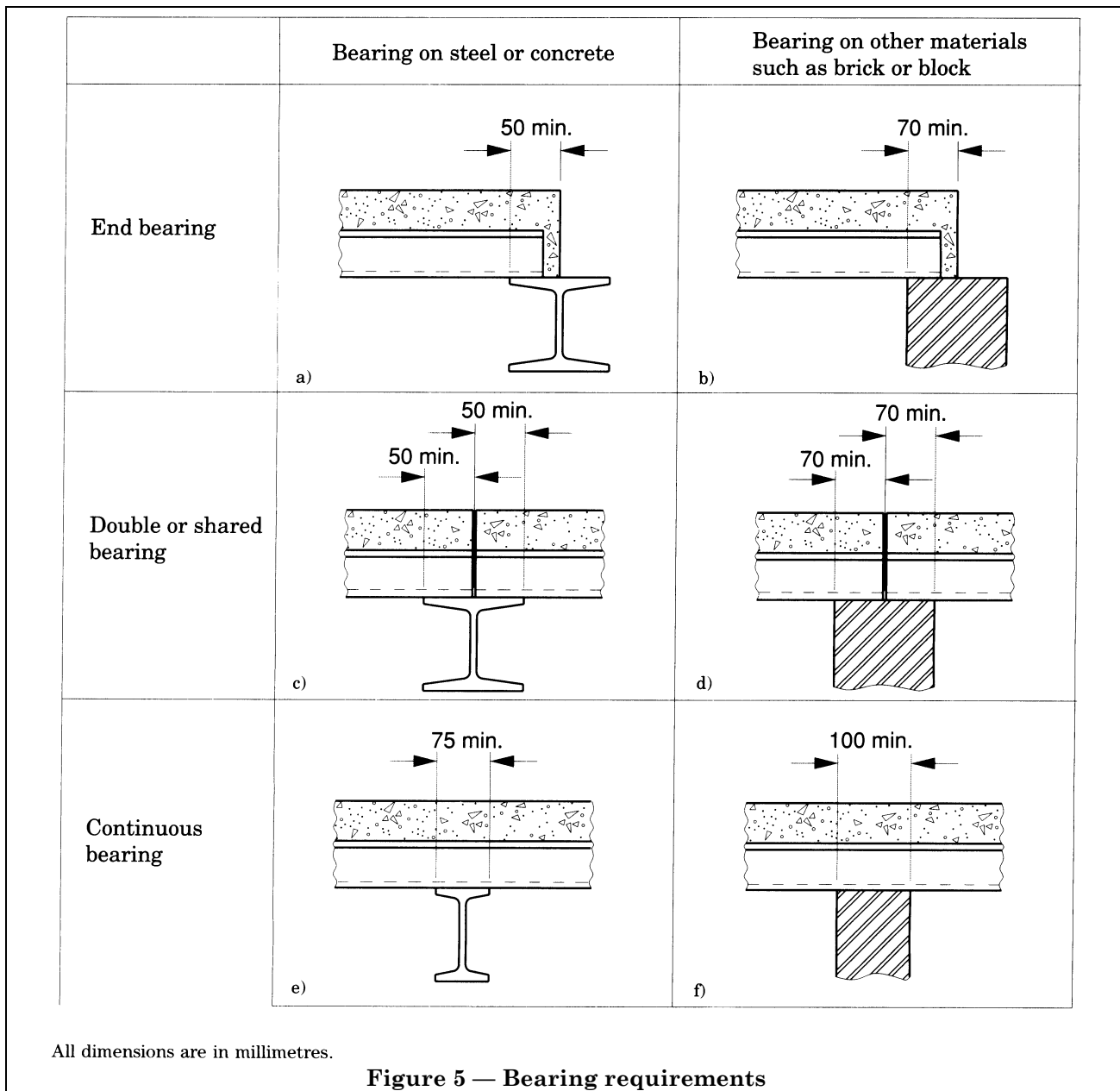

#### 4.6.4 Embossed profiled sheets

Embossed profiled sheets, as illustrated in Figure 4 b), Figure 4 c) and Figure 4 d), should be designed to develop shear connection through embossments (or embossments and indentations) in the webs and/or flanges of the sheets.

#### 4.6.5 Small holes in profiled sheets

Holes in the webs and/or flanges of profiled steel sheets, intended to develop shear connection, should be sufficiently large for concrete to fill the hole, but sufficiently small to minimize the loss of fine material from the concrete, unless a permanent backing tape is provided on the underside which prevents this loss.

#### 4.6.6 End anchorage

Shear connectors may be used as end anchorages to produce composite action in slabs which are designed as simply supported. Where sheets are not continuous over a support, end anchors should be provided at the ends of both sheets.

Where the end anchorage provided by shear connectors is used in conjunction with the shear bond between the concrete and the profiled steel sheets, account should be taken of the influence of the deformation capacity of the shear connectors on the shear bond between the concrete and the sheets, as recommended in 6.4.3.

The necessary interaction between stud shear connectors and the profiled steel sheets should normally be achieved by welding them to the structural steelwork by the site technique of through-the-sheet welding. Shear connectors directly attached to the structural steelwork prior to placing the profiled steel sheets should not be used as end anchorages unless the sheets are also attached to the steelwork as recommended in 4.8.1, by means of fixings of sufficient capacity.

**NOTE** If studs are welded to the beams prior to placing the profiled steel sheets, it may be found necessary to use single span sheets, in which case stop ends (see 4.8.4.3) may be needed to prevent concrete loss.

Where end anchorage is provided by types of shear connectors which connect the concrete slab directly to the profiled steel sheets, such as self-drilling self-tapping screws with enlarged washers, account should be taken of the deformation capacity of such shear connectors on the interaction between the slab and the sheets.

Where shear connectors used as end anchorages are assumed in design to act also as shear connectors in composite beams, reference should be made to 6.10.1.

Where composite slabs are used in conjunction with reinforced concrete beams (see 6.10.2), any end anchorage required should normally be achieved by means of reinforcing bars.

#### 4.6.7 Sheet edges

For profiles such as that shown in Figure 4 e), the edges of adjacent sheets should be overlapped or crimped in such a way as to provide an effective horizontal shear transfer between the sheets.

### 4.7 Minimum bearing requirements

In all cases the bearing length of a composite slab should be sufficient to satisfy the recommendations of 5.2 for load carrying capacity as permanent formwork and the recommendations of BS 8110 for load carrying capacity as a composite slab.

Composite slabs bearing on steel or concrete should normally have an end bearing of not less than 50 mm [see Figure 5 a) and Figure 5 c)]. For composite slabs bearing on other materials, the end bearing should normally be not less than 70 mm [see Figure 5 b) and Figure 5 d)].

For continuous slabs the minimum bearing at intermediate supports should normally be 75 mm on steel or concrete and 100 mm on other materials [see Figure 5 e) and Figure 5 f)].

Where smaller bearing lengths are adopted, account should be taken of all relevant factors such as tolerances, loading, span, height of support and provision of continuity reinforcement. In such cases, precautions should also be taken to ensure that fixings (see 4.8.1) can still be achieved without damage to the bearings, and that collapse cannot occur as a result of accidental displacement during erection.

### 4.8 Constructional details

#### 4.8.1 Sheet fixings

The design should incorporate provision for the profiled steel sheets to be fixed:

- to keep them in position during construction so as to provide a subsequent safe working platform;
- to ensure connection between the sheets and supporting beams;
- to ensure connection between adjacent sheets where necessary;
- to transmit horizontal forces where necessary;
- to prevent uplift forces displacing the sheets.

For fixing sheets to steelwork, the following types of fixing are available:

- shot fired fixings;
- self-tapping screws;
- welding;
- stud shear connectors welded through the sheeting;
- bolting.

Due consideration should be given to any adverse effect on the supporting members.

Site welding of very thin sheets should not be relied on to transfer end anchorage forces, unless the practicality and quality of the welded connections can be demonstrated by tests.

When sheets are to be attached to brickwork, blockwork, concrete or other materials where there is a danger of splitting, fixing should be by drilling and plugging or by the use of suitable proprietary fixings.

The number of fasteners should be not less than two per sheet at the ends of sheets nor less than one per sheet where the sheets are continuous. The spacing of fasteners should be not greater than 500 mm at the ends of sheets nor greater than 1 000 mm where the sheets are continuous. At side laps the sheets should be fastened to each other, as necessary, to control differential deflection, except where the sides of the sheets are supported or are sufficiently interlocking.

The design of all sheet fixings should be in accordance with BS 5950-6<sup>5)</sup>.

#### 4.8.2 Cantilever edges

The design should include provisions for adequate support of profiled steel sheets during construction at all cantilever edges and the like, including unsupported edges occurring at cut-outs or openings for columns.

### 4.8.3 Openings

#### 4.8.3.1 Permanent openings

Reinforcement should be provided around permanent openings to avoid cracking of the composite slab.

#### 4.8.3.2 Temporary openings

Where sheets are required to be temporarily left out (or cut out) during construction, due allowance should be made for the resulting loss of continuity in the design of the profiled steel sheeting (see section 5). Where necessary, thicker sheets or temporary supports should be used at such locations.

### 4.8.4 Slab construction

#### 4.8.4.1 Preparation

All extraneous grease, oil, dirt and deleterious matter should be removed from the upper surface of the sheets, but any greasiness remaining on the sheets from the forming process need not be removed.

#### 4.8.4.2 Construction joints

Construction joints in composite slabs should be positioned close to the supporting beams.

#### 4.8.4.3 Stop ends

Stop ends should be provided where necessary to prevent loss of grout at supports at which the sheeting is discontinuous.

### 4.8.5 Waterproofing

Where composite slabs are used for roofs, or other locations with impervious surface membranes, the design should incorporate provision for the free passage of water vapour.

<sup>5)</sup> In preparation.

## Section 5. Design: profiled steel sheeting

### 5.1 General

The design of profiled steel sheeting supporting loads before composite action is developed should follow the recommendations given in this section.

The recommendations given in BS 5950-6<sup>6)</sup> should be followed for the calculation of cross-sectional properties. Alternatively the load-carrying capacity of the profiled steel sheeting should be determined by testing (see 5.2).

Embossments and indentations designed to provide composite action should be ignored when calculating the cross-sectional properties of the steel sheets.

NOTE The cross-sectional properties of commercially available profiles can be found in manufacturers' literature, together with information on effective cross-sectional properties at various stress levels.

### 5.2 Load carrying capacity

For design purposes, the loads carried by the profiled steel sheeting should be the dead load of the sheets, wet concrete and reinforcement, the construction loads (see 2.2.3), the effects of any temporary propping used at this stage and, where necessary, wind forces.

For simple spans, the capacity of the profiled steel sheeting should be determined as recommended in BS 5950-6<sup>6)</sup> by either:

- a) calculation; or
- b) testing.

For sheets continuous over more than one span, the capacity should be determined either by using one of the methods recommended for simple spans or from a hybrid design method, based on elastic section properties supplemented by information obtained by testing.

NOTE An appropriate hybrid design method is given in CIRIA Technical Note 116[1].

### 5.3 Deflection of profiled steel sheeting

The deflections of profiled steel sheeting should be calculated as recommended in BS 5950-6<sup>6)</sup> using the serviceability loads (see 2.5.1) for the construction stage, comprising the weight of the profiled sheets and the wet concrete only. These deflections should not normally exceed the following:

- a)  $L_p/180$  (but  $\leq 20$  mm) when the effects of ponding are not taken into account;
- b)  $L_p/130$  (but  $\leq 30$  mm) when the effects of ponding are taken into account, i.e. the weight of additional concrete due to the deflection of the sheeting is included in the deflection calculation;

where  $L_p$  is the effective span of the profiled steel sheets.

These limits should be increased only where it can be shown that greater deflections will not impair the strength or efficiency of the slab.

These limits should be reduced, if necessary, where soffit deflection is considered important, e.g. for service requirements or aesthetics.

When the deflection [calculated as in item a] exceeds  $D_s/10$ , where  $D_s$  is the overall depth of the composite slab, the additional weight of concrete due to the deflection of the sheeting should be taken into account in the self-weight of the composite slab, for use in section 6 and in the design of the supporting structure.

<sup>6)</sup> In preparation.

## Section 6. Design: composite slab

### 6.1 General

#### 6.1.1 Continuity

Composite slabs should be designed as either:

- a) simply supported, with nominal reinforcement over intermediate supports in accordance with 6.8; or
- b) continuous, with full continuity reinforcement over intermediate supports in accordance with BS 8110.

NOTE Generally, composite slabs are designed as simply supported, with nominal steel mesh reinforcement over supports.

#### 6.1.2 Continuous slabs

For multiple spans designed as a continuous slab subjected to uniformly distributed imposed load, only the following arrangements of imposed load need be considered.

- a) alternate spans loaded;
- b) two adjacent spans loaded.

For dead load, the same value of the partial safety factor for loads  $\gamma_f$  should be applied on all spans.

#### 6.1.3 Effects of holes and ducts

Where holes or ducts interrupt the continuity of a composite slab, the region affected should be designed as reinforced concrete and reference should be made to BS 8110.

#### 6.1.4 Transverse spanning

Where slabs or portions of slabs span onto supports in the transverse direction, this aspect of the design should be in accordance with BS 8110.

### 6.2 Strength

#### 6.2.1 Design criteria

The capacity of the composite slab should be sufficient to resist the factored loads for the ultimate limit state. The critical sections indicated in Figure 6 should be considered. Section 2-2 represents the interface between the concrete and the profiled steel sheets. The following design criteria for the various modes of failure should be considered.

- a) *Flexural failure at section 1-1*: this criterion is represented by the moment capacity of the composite slab, based on full shear connection at section 2-2 (see 6.3).
- b) *Longitudinal slip at section 2-2*: this criterion is represented by the shear-bond capacity. In this case the capacity of the composite slab is governed by the shear connection at section 2-2 (see 6.4).
- c) *Vertical shear failure at section 3-3*: this criterion is represented by the vertical shear capacity of the composite slab (see 6.5.1).

NOTE Vertical shear failure is rarely critical.

The relevant design criterion and capacity should be determined either by the procedure given in 6.2.2 or else by specific testing (see 6.2.3).

Punching shear should also be checked where concentrated loads or reactions are applied to the slab (see 6.5.2).

Where composite slabs are designed as continuous with full continuity reinforcement over internal supports in accordance with BS 8110, the resistance to shear-bond failure contributed by the adjacent spans should be allowed for by basing the value of the shear span  $L_v$  for use as described in 6.4.1 on an equivalent simple span between points of contraflexure when checking the shear-bond capacity of an internal span. However, for end spans the value of  $L_v$  should be based on the full end span length.

#### 6.2.2 Design procedure

Where propped construction is used, the composite slab should be designed assuming that all the loading acts on the composite slab.

Where unpropped construction is used, the shear forces to be resisted by the composite slab should be determined allowing for the separate effects of loading applied to the profiled steel sheeting or to the composite slab, as appropriate. However, the moments to be resisted by the composite slab should be determined assuming that all the loading acts on the composite slab.

NOTE Generally, composite slabs are constructed unpropped.

#### 6.2.3 Specific tests

As an alternative to the design procedure given in 6.2.2, the relevant design criterion and capacity for a particular arrangement of profiled steel sheets and concrete slab may be determined by specific tests in accordance with 8.2.

### 6.3 Moment capacity

The moment capacity for full shear connection should be treated as an upper bound to the capacity of a composite slab. The moment capacity of a composite slab should be calculated as for reinforced concrete, with the profiled steel sheets acting as tensile reinforcement.

The moment capacity in positive moment regions should be calculated assuming rectangular stress blocks for both concrete and profiled steel sheets. The design strengths should be taken as  $0.45f_{cu}$  for the concrete and  $p_{yp}$  for the profiled steel sheeting (see Figure 7). The lever arm  $z$  should not exceed  $0.95d_s$  and the depth of the stress block for the concrete should not exceed  $0.45d_s$ .

Tension reinforcement in positive moment regions should be neglected, unless the moment capacity is determined by testing.

The moment capacity in negative moment regions should be determined as recommended in BS 8110. In determining the negative moment capacity, the profiled steel sheets should be neglected.

NOTE Where steel fabric reinforcement is used to resist negative moments, refer to 3.2.2.

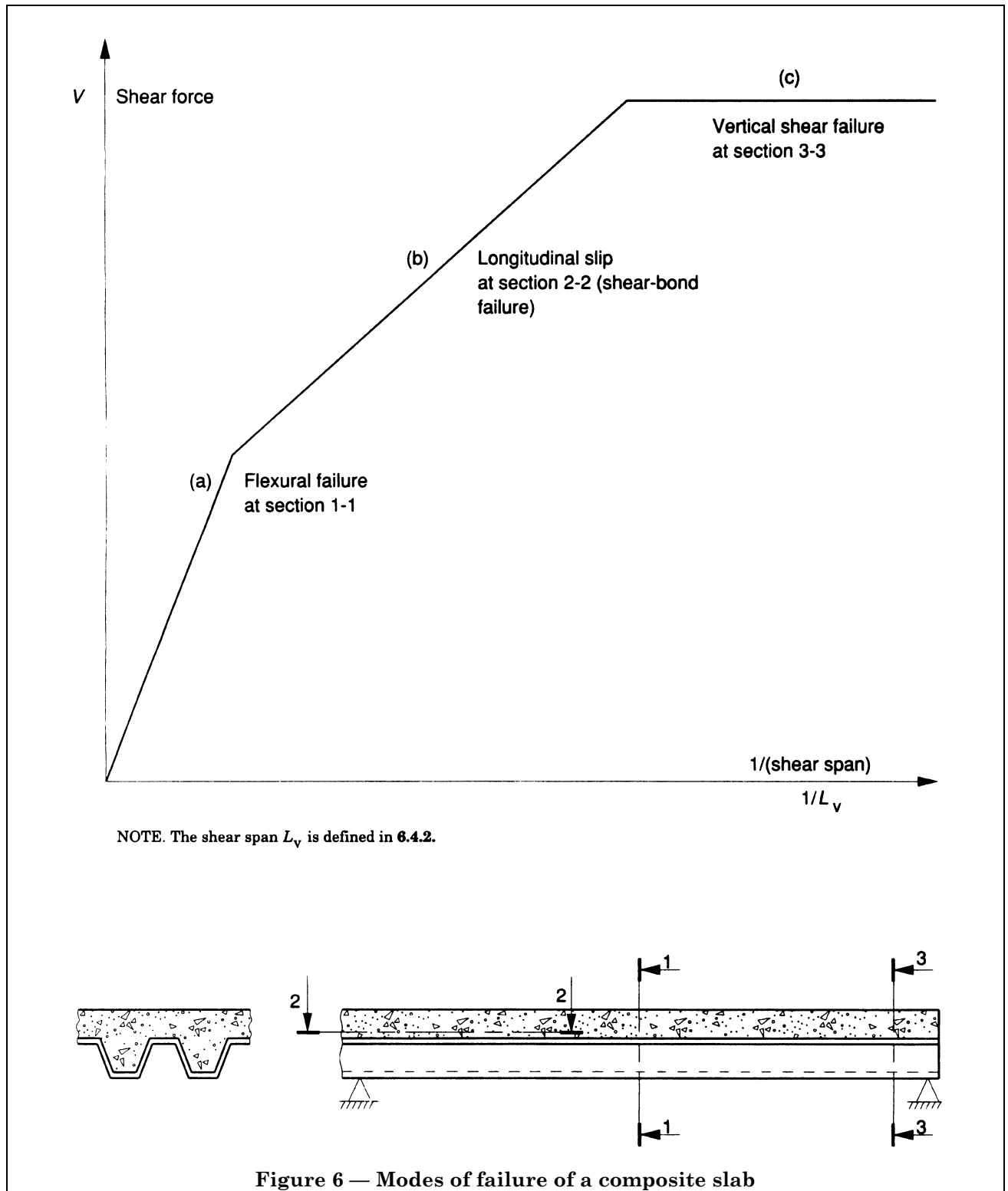



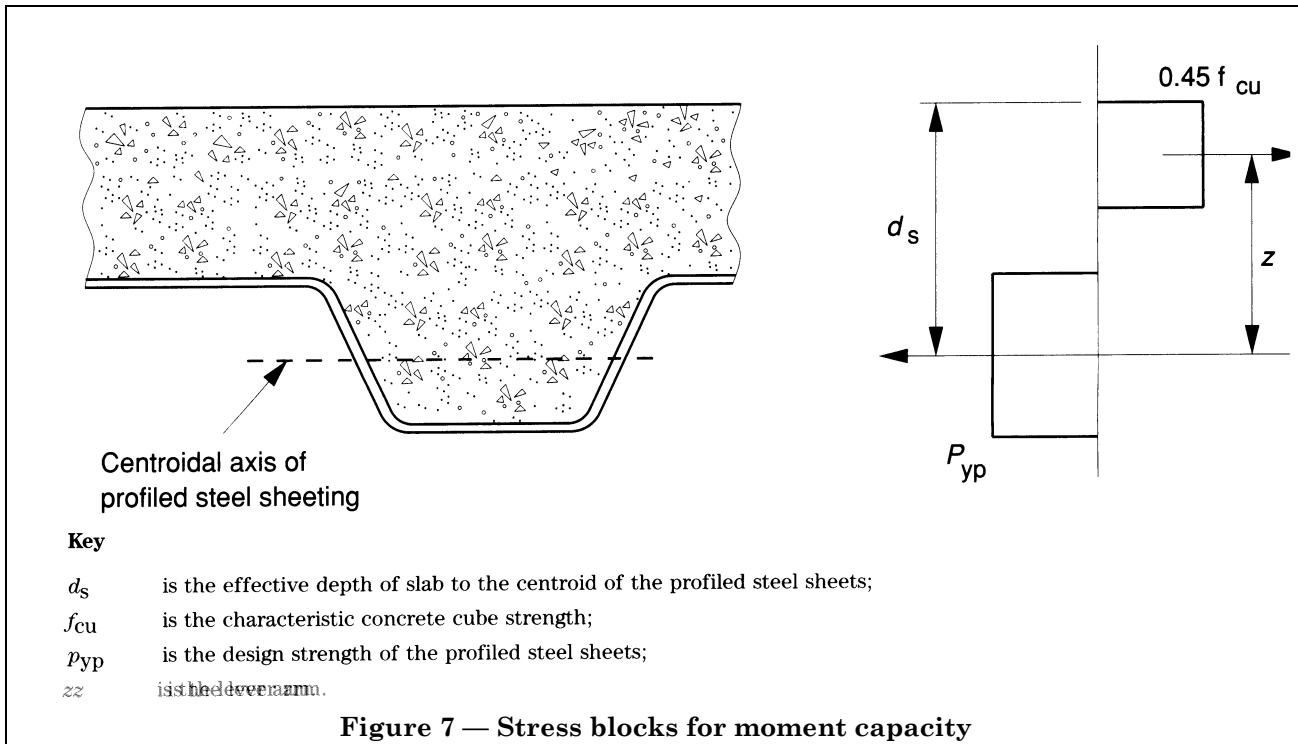

## 6.4 Shear capacity

### 6.4.1 Shear-bond capacity $V_s$

When the capacity of a composite slab is governed by shear bond, it should be expressed in terms of the vertical shear capacity at the supports.

Generally the shear-bond capacity  $V_s$  (in N) should be calculated using

$$V_s = \frac{B_s d_s}{1.25} \left( \frac{m_r A_p}{B_s L_v} + k_r \sqrt{f_{cu}} \right)$$

where

- $A_p$  is the cross-sectional area of the profiled steel sheeting (in  $\text{mm}^2$ );
- $B_s$  is the width of the composite slab (in mm);
- $d_s$  is the effective depth of slab to the centroid of the profiled steel sheets (in mm);
- $f_{cu}$  is the characteristic concrete cube strength (in  $\text{N/mm}^2$ );
- $k_r$  is an empirical parameter (in  $\text{N/mm}$ );
- $L_v$  is the shear span of the composite slab (in mm), determined in accordance with 6.4.2, but see also 6.2.1; and
- $m_r$  is an empirical parameter (in  $\text{N/mm}^2$ ).

NOTE 1 The factor of 1.25 is a partial safety factor for resistances  $\gamma_m$ , selected on the basis of the behaviour and mode of failure of the slab.

The empirical parameters  $m_r$  and  $k_r$  in this formula should be obtained from parametric tests for the particular profiled sheet as recommended in 8.3.

In using this formula the value of  $A_p$  should not be taken as more than 10 % greater than that of the profiled steel sheets used in the tests and the value of  $f_{cu}$  should not be taken as more than  $1.1f_{cm}$  where  $f_{cm}$  is the value used in 8.3.3 to determine  $m_r$  and  $k_r$ .

When the value of  $k_r$  obtained from the tests is negative, the nominal strength grade of the concrete used in this formula should be not less than the nominal strength grade of the concrete used in the tests.

The shear-bond capacity of a lightweight concrete composite slab should be assumed to be the same as that of a normal weight composite slab made with concrete of the same strength grade.

NOTE 2 As an alternative to calculation of the shear-bond capacity, the load carrying capacity of the composite slab can be determined directly by means of specific tests (see 8.2).

Where it is necessary to use end anchors to increase the resistance to longitudinal shear above that provided by the shear-bond capacity  $V_s$ , reference should be made to 6.4.3.

### 6.4.2 Shear span $L_v$

The shear span  $L_v$  should be taken as the distance from the support to the point within the span where at shear-bond failure a transverse crack in the concrete is deemed to occur (see Figure 8).

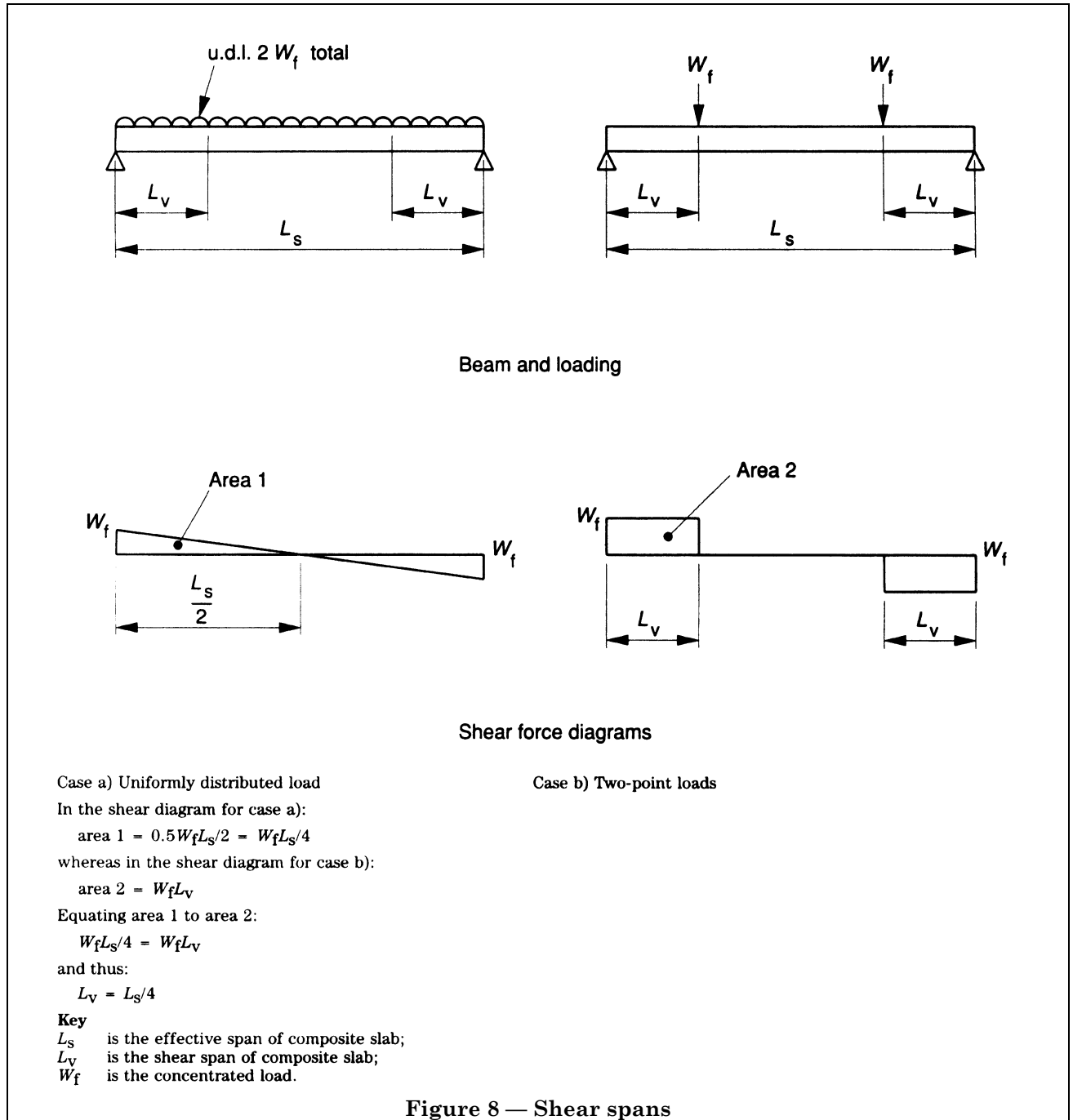

The shear span  $L_v$  should be taken as:

- $L_s/4$  for a uniformly distributed load;
- the distance from the support to the nearest concentrated load for a symmetrical two-point load system.

For other loading arrangements, including partial distributed loads and asymmetrical point load systems, the shear span  $L_v$  should be determined on the basis of appropriate tests or by approximate calculations similar to the following.

The  $L_s/4$  shear span for a uniformly distributed load is obtained by equating the area under the shear force diagram for the uniformly distributed load to that due to a symmetrical two-point load system, both loadings having the same total value  $2 W_f$  (see Figure 8).

#### 6.4.3 End anchorage

End anchorage may be provided by welded stud shear connectors attached to supporting steel beams by the technique of through-the-sheet welding with an end distance, measured to the centre line of the studs, of not less than 1.7 times the stud diameter, or by other suitable ductile shear connectors. Provided that not more than one shear connector is used in each rib of the profiled steel sheets, the shear capacity per unit width should be determined from

$$\bar{V}_a = NP_a(d_s - x_c/2)/L_x$$

where

- $N$  is the number of shear connectors attached to the end of each span of sheets, per unit length of supporting beam;
- $d_s$  is the effective depth of the slab to the centroid of the profiled steel sheeting;
- $x_c$  is the depth of concrete in compression at midspan (for simplicity  $x_c$  may conservatively be taken as 20 mm);
- $L_v$  is the shear span (for a uniformly loaded slab  $L_v$  is span/4); and
- $P_a$  is the end anchorage capacity per shear connector.

For the conditions defined above, the end anchorage capacity should be obtained from

$$P_a = 0.4Q_k$$

where

- $Q_k$  is the characteristic resistance of the shear connector, determined in accordance with BS 5950-3.1:1990.

NOTE Values of  $Q_k$  should be reduced by 10 % when lightweight concrete is used, see BS 5950-3.1:1990.

Where end anchorage is used in conjunction with the shear bond between the concrete and the profiled steel sheets, the combined resistance to longitudinal shear should be limited as follows:

$$\bar{V}_c = \bar{V}_s + 0.5\bar{V}_a \quad \text{but} \quad \bar{V}_c \leq 1.5\bar{V}_s$$

where

- $\bar{V}_c$  is the total longitudinal shear capacity per unit width of slab; and
- $\bar{V}_s$  is the shear bond capacity per unit width.

## 6.5 Vertical shear and punching shear

### 6.5.1 Vertical shear capacity

The vertical shear capacity  $V_v$  of a composite slab over a width equal to the distance between centres of ribs, should be determined from the following:

- for open trough profile sheets:

$$V_v = b_a d_s v_c$$

- for re-entrant trough profile sheets:

$$V_v = b_b d_s v_c$$

where

- $b_a$  is the mean width of a trough of an open profile (see Figure 2);
- $b_b$  is the minimum width of a trough of a re-entrant profile (see Figure 2);
- $d_s$  is the effective depth of the slab to the centroid of the sheet (see Figure 2); and
- $v_c$  is the design concrete shear stress from BS 8110-1:1985 (modified for lightweight concrete in accordance with BS 8110-2:1985) taking  $A_s$  as  $A_p$ ,  $d$  as  $d_s$  and  $b$  as  $B_s$ ).

### 6.5.2 Punching shear capacity

The punching shear capacity  $V_p$  of a composite slab at a concentrated load should be determined from the method given in BS 8110-1:1985 taking  $d$  as  $D_s - D_p$  and the critical perimeter  $u$  as defined in Figure 9.

## 6.6 Deflection of the composite slab

### 6.6.1 Limiting values

The deflection of the composite slab should be calculated using serviceability loads  $W_{ser}$  (see 2.5.1), excluding the self-weight of the composite slab. The deflection of the profiled steel sheeting due to its own weight and the weight of wet concrete (calculated as in 5.3) should not be included.

The deflection of the composite slab should not normally exceed the following:

- deflection due to the imposed load:  $L_s/350$  or 20 mm, whichever is the lesser;
- deflection due to the total load less the deflection due to the self-weight of the slab plus, when props are used, the deflection due to prop removal:  $L/250$ .

These limits should be increased only where it can be shown that greater deflections will not impair the strength or efficiency of the slab, lead to damage to the finishes or be unsightly.

### 6.6.2 Calculation

The deflection limits given in 6.6.1 should be satisfied either by calculation as outlined in this subclause, or by satisfying the recommended span-to-depth ratios given in 6.6.3.

For uniformly distributed loading, the following approximate expressions may be used to calculate the deflection:

- for simply supported spans (with nominal reinforcement over intermediate supports)

$$\delta = \frac{5}{384} \frac{W_{\text{ser}} L_s^3}{EI_{\text{CA}}}$$

- for end spans of continuous slabs (with full continuity reinforcement over intermediate supports) of approximately equal span, i.e. within 15 % of the maximum span

$$\delta = \frac{1}{100} \frac{W_{\text{ser}} L_s^3}{EI_{\text{CA}}}$$

- for two-span slabs (with full continuity reinforcement over the internal support)

$$\delta = \frac{1}{135} \frac{W_{\text{ser}} L_s^3}{EI_{\text{CA}}}$$

where

$E$  is the modulus of elasticity of the profiled steel sheets;

$I_{\text{CA}}$  is the second moment of area of the composite slab about its centroidal axis;

$L_s$  is the effective span of the composite slab; and

$W_{\text{ser}}$  is the serviceability load.

NOTE The factor 1/100 is derived by dividing 5/384 (for the simply supported case) by a factor of 1.3. The factor 1.3 is a ratio obtained from the basic span/effective depth ratios given in BS 8110-1 for continuous and simply supported spans. The factor 1/135 is derived by comparing two-span and three-span cases.

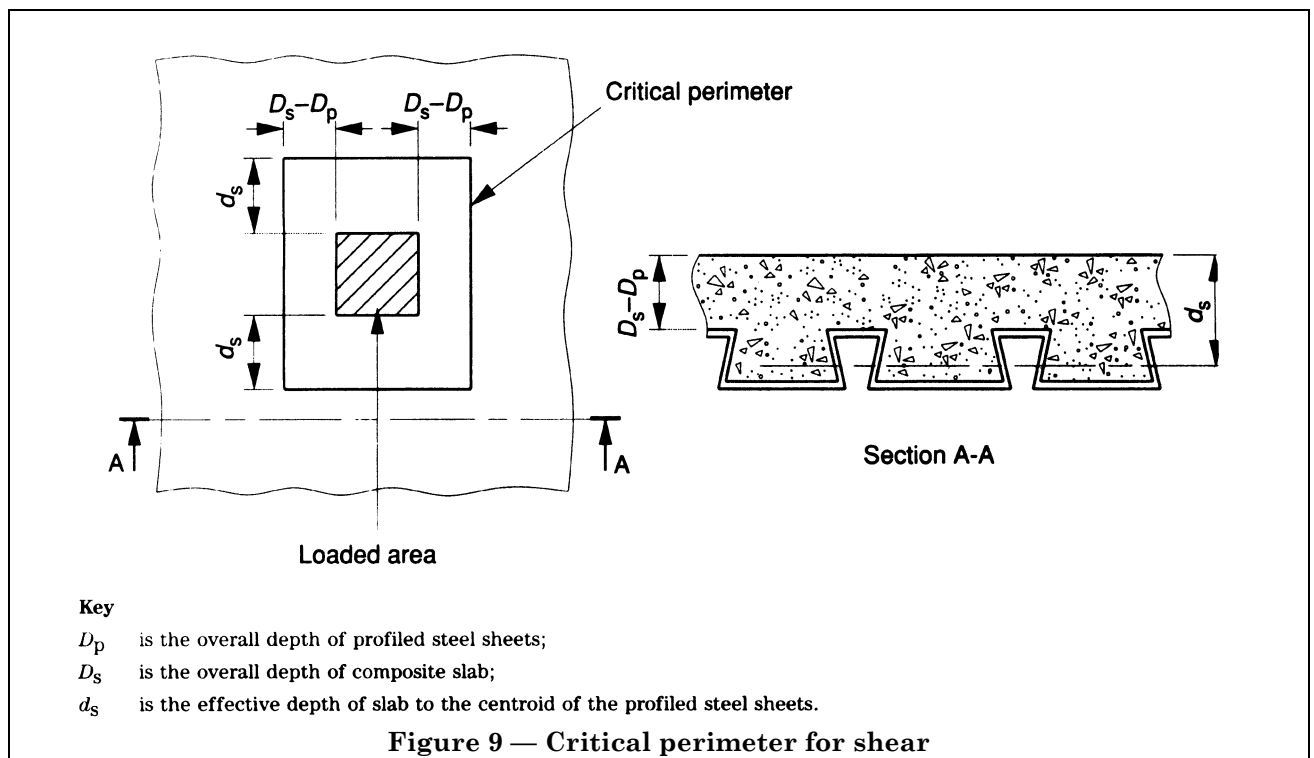

The value of the second moment of area of the composite slab  $I_{CA}$  about its centroidal axis (in equivalent steel units) should be taken as the average of

$I_{CA}$  for the cracked section (i.e. the compression area of the concrete cross section combined with the profiled steel sheets on the basis of modular ratio) and

$I_{CA}$  for the gross section (i.e. the entire concrete cross section combined with the profiled steel sheets on the basis of modular ratio).

The modular ratio should be determined as recommended in BS 5950-3.1:1990.

### 6.6.3 Span-to-depth ratios

As an alternative to calculation as recommended in 6.6.2, the limiting deflections given in 6.6.1 should be assumed to be satisfied for slabs with nominal continuity reinforcement over intermediate supports, if the span-to-depth ratios do not exceed the values given in Table 2. In Table 2, the depth should be taken as the overall depth of the composite slab  $D_s$  and the span as the effective span of the profiled steel sheets  $L_p$ .

**Table 2 — Span-to-depth ratios**

Type of concrete	Condition		
	Single spans	End spans	Internal spans
Normal weight	30	35	38
Lightweight	25	30	33

NOTE The values in this table apply to slabs with nominal continuity reinforcement over intermediate supports. For slabs designed as continuous with full continuity over intermediate supports, reference should be made to BS 8110.

### 6.7 Concentrated loads

Where discrete concentrated loads or line loads running transverse to the span are to be supported by a slab, they should be considered to be distributed over an effective load width  $b_m$  (see Figure 10), measured immediately above the ribs of the profiled steel sheets, and determined as follows.

a) Where the load is applied directly onto the structural slab:

$$b_m = b_o + 2(D_s - D_p)$$

b) Where the load is applied directly onto joint-free durable finishes:

$$b_m = b_o + 2t_f + 2(D_s - D_p)$$

The effective width of slab resisting bending moments and shear forces due to a concentrated load should be determined as follows.

1) For resisting bending moments:

i) simple slabs

$$b_{eb} = b_m + 2 \left( 1 - \frac{a}{L_s} \right) a$$

ii) continuous slabs

$$b_{eb} = b_m + \frac{4}{3} \left( 1 - \frac{a}{L_s} \right) a$$

2) For resisting shear forces:

$$b_{er} = b_m + \left( 1 - \frac{a}{L_s} \right) a$$

where

$a$  is the distance from the load to the nearer support; and

$L_s$  is the effective span of the slab.

A line load running parallel to the span should be treated as a series of concentrated loads.

Where there are discrete concentrated loads or line loads, transverse reinforcement should be placed on or above the profiled steel sheets. It should have a cross-sectional area of not less than 0.2 % of the concrete section above the ribs ( $D_s - D_p$ ) and should extend over a width of not less than  $b_{eb}$ . This transverse reinforcement, which may include reinforcement provided for other purposes, should be ductile (see 3.2.2).

### 6.8 Nominal reinforcement at intermediate supports

Where continuous composite slabs are designed as simply supported, nominal steel fabric reinforcement should be provided over intermediate supports. For mild exposure conditions in accordance with BS 8110-1:1985, the cross-sectional area of reinforcement in a longitudinal direction should be not less than 0.1 % of the gross cross-sectional area of the concrete at the support.

For propped construction consideration should be given to increasing the area of steel reinforcement over supports as appropriate, depending on the span and the crack widths that can be tolerated.

For other conditions of exposure reference should be made to BS 8110.

Where such nominal reinforcement also provides fire resistance, see also 3.2.2.

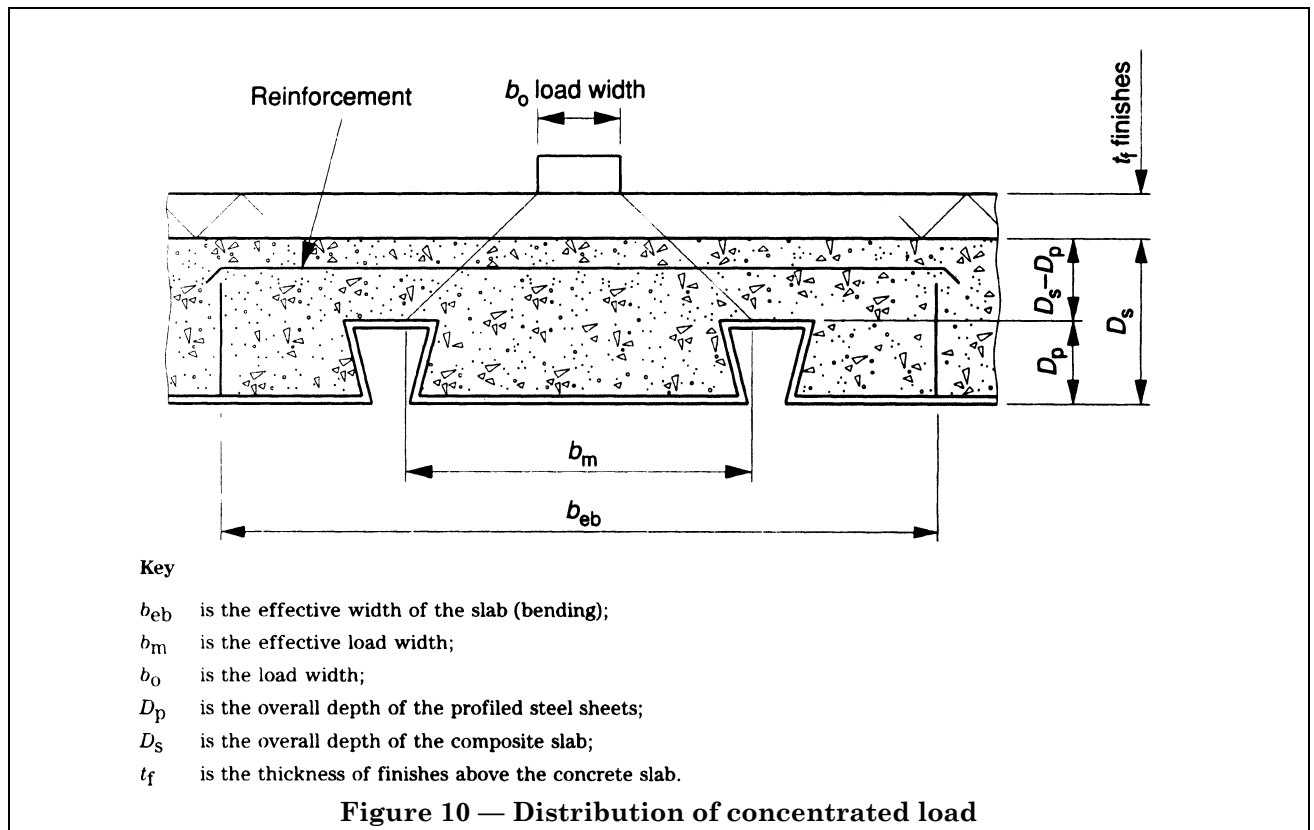

## 6.9 Transverse reinforcement

The cross-sectional area of transverse reinforcement in the form of steel mesh reinforcement should be not less than 0.1 % of the cross-sectional area of the concrete above the ribs.

## 6.10 Shear connection

### 6.10.1 Composite steel beams

Where composite slabs with profiled steel sheeting are used to form the slabs of composite steel beams, the design of the shear connection should be in accordance with BS 5950-3.1:1990.

Where stud shear connectors are assumed in design to also act as end anchors (see 4.6.6 and 6.4.3) in simply supported composite slabs, in addition to connecting the slab to the steel beam, the following criteria should all be satisfied:

$$F_a \leq P_a$$

$$F_b \leq P_b$$

$$(F_a/P_a)^2 + (F_b/P_b)^2 \leq 1.1$$

where

$F_a$  is the end anchorage force per shear connector;

$F_b$  is the beam longitudinal shear force per shear connector;

$P_a$  is the end anchorage capacity per shear connector (see 6.4.3);

$P_b$  is the capacity per shear connector for composite beam design in accordance with BS 5950-3.1:1990.

### 6.10.2 Composite concrete beams

Where composite slabs with profiled steel sheeting are used to form the slabs of composite concrete beams, the design of the shear connection should be in accordance with the recommendations for composite concrete construction given in BS 8110-1:1985.

## Section 7. Fire resistance

### 7.1 General

The fire resistance of a composite slab depends not only on the minimum thickness of concrete and the average concrete cover to any additional reinforcement in the tensile zone, but also on its overall design including any fire protective treatment and restraint offered by the supporting structure.

NOTE With profiled steel sheets it is seldom necessary to cover the soffit in order to obtain the desired period of fire resistance.

### 7.2 Minimum thickness of concrete

The concrete should have at least the minimum thickness for thermal insulation recommended in BS 5950-8:1990.

### 7.3 Determination of fire resistance

Fire resistance may be determined by any of the following:

- a) Testing in accordance with BS 476-21:1987.
- b) Using constructional details conforming to the recommendations of BS 5950-8:1990.
- c) Calculation methods conforming to the recommendations of BS 5950-8:1990.
- d) Reference to design tables based on the recommendations of BS 5950-8:1990.

NOTE An appropriate calculation method is given in SCI publication 056[2].

NOTE Simplified design tables for the fire resistance of composite slabs using steel fabric reinforcement are given in CIRIA Special Publication 42 and in SCI Publication 056[3].

## Section 8. Testing of composite slabs

### 8.1 General

The tests described in this section are of two types.

a) *Specific tests.* These are full-scale tests of a particular proposed composite slab, using actual loading or a close approximation to it. The purpose is to determine the load carrying capacity of a slab directly by testing. The results obtained should be applied only to the particular case of span, profiled steel sheets and concrete grade and thickness tested.

b) *Parametric tests.* These are a series of full-scale tests of a proposed type of composite slab, over a range of parameters covering loading, profiled steel sheet thickness, concrete thickness and spans. The purpose of these tests is to obtain data to enable the values of the empirical parameters  $k_r$  and  $m_r$  to be established, which are then used to determine the shear-bond capacity  $V_s$  (see 6.4.1).

All testing should be carried out by recognized testing organizations with appropriate experience of structural testing.

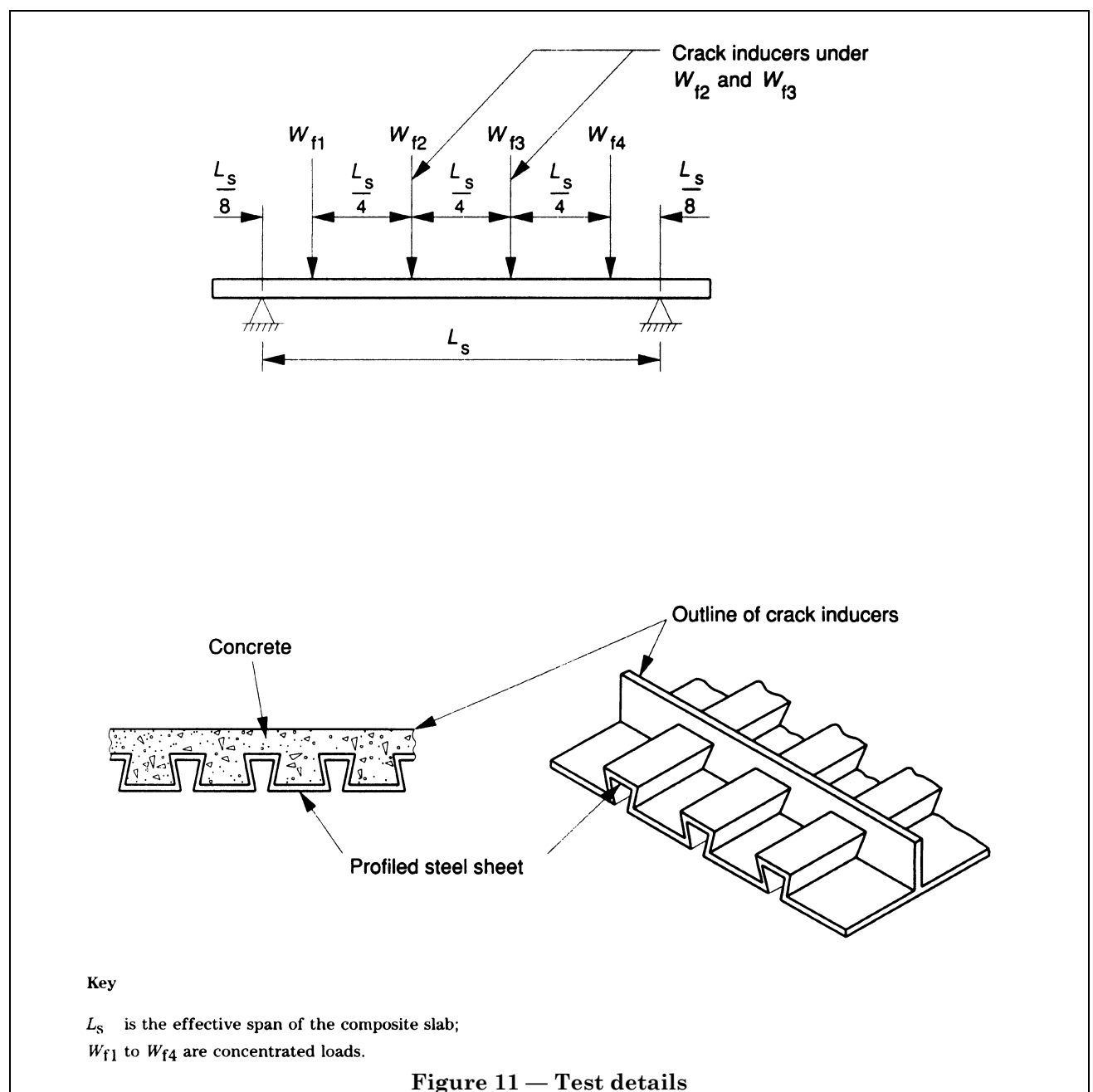



## 8.2 Specific tests

### 8.2.1 Testing arrangement

A minimum of three full-scale tests should be carried out on representative samples of the proposed slab construction using actual loadings or, in the case of uniformly distributed loads, a close simulation of the loading as shown in Figure 11. In the case of continuous spans, the tests should either be on multiple spans or be on a single span with simulated support moments.

The width of the test slabs should have a value not less than the largest of the following:

- a) three times the overall depth,  $3D_s$ ;
- b) 600 mm;
- c) the width of the profiled steel sheeting.

Thin sheet steel crack inducers extending to the full depth of the slab and coated with a debonding agent should be placed across the full width of the test slab to ensure that the cracks form in the tensile zone of the slab. In the case of four-point loading, the crack inducers should be positioned under the two more central loads, as shown in Figure 11. For non-uniform or asymmetrical loading arrangements, the crack inducers should be positioned at the points of maximum bending moment.

The surface of the profiled steel sheets should be in the "as-rolled" condition, no attempt being made to improve the bond by degreasing the surface. A minimum of four concrete test cubes should be prepared at the time of casting the test slabs. The cubes should be cured under the same conditions as the slabs and tested at the time of loading the slab. The ultimate tensile strength and yield strength of the profiled steel sheets should be obtained from coupon test specimens cut from samples of each of the sheets used to form the composite test slabs. The coupons should be tested in accordance with BS EN 10002-1:1990.

### 8.2.2 Test load procedure

#### 8.2.2.1 General

The load carrying capacity of the proposed composite slab construction should be determined from tests representing the effects of loading applied over a period of time. The testing procedure should consist of the following two parts:

- an initial dynamic test in which the slab is subjected to a cyclic load (see 8.2.2.2);
- a static test in which the applied load is increased until the slab fails (see 8.2.2.3).

#### 8.2.2.2 Initial dynamic test

A test slab, representative of the proposed composite slab should first be subjected to an applied cyclic load which varies between a lower value not greater than  $0.5 W_w$  and an upper value not less than  $1.5 W_w$ , where  $W_w$  is the anticipated value of the applied load (at  $\gamma_f = 1.0$ ) excluding the weight of the composite slab. This loading should be applied for 10 000 cycles in a time of not less than 3 h. The mid-span deflection should be recorded during the test. The slab should be deemed to have satisfactorily completed this initial dynamic test if the maximum deflection does not exceed  $L_s/50$ , where  $L_s$  is the effective span of the composite slab.

#### 8.2.2.3 Static test

After satisfactory completion of the initial dynamic test, the same slab should be subjected to a static test in which the applied load is increased progressively until failure occurs. The failure load applied to the test slab, the mid-span deflection and the load at which the mid-span deflection reaches  $L_s/50$  should be recorded.

#### 8.2.2.4 Applied load capacity

The load capacity  $W_c$  (at  $\gamma_f = 1.0$ ) for the load applied to the slab should, for design purposes, be taken as the lowest of the following:

- a) 0.75 of the average applied static load (for a minimum of three tests) at a deflection of  $L_s/50$ , the slab not having failed;
- b) 0.5 of the average applied static load at failure  $W_{st}$ , when the slab fails with sudden and excessive end slip (i.e. when only partial horizontal shear connection is present between the concrete and the profiled steel sheets);
- c) 0.75 of the average applied static load at failure  $W_{st}$ , when the slab fails without sudden and excessive end slip (i.e. when full horizontal shear connection is present between the concrete and the profiled steel sheeting);
- d) the upper value of the applied load used for the dynamic test.

If the applied load in the static test has reached twice  $W_w$  but has not caused failure in the slab under a), b) or c), then the dynamic and static tests may be repeated at higher values of  $W_w$ .

### 8.2.3 Reporting of test results

The following information should be included in the report for each slab tested:

- a) anticipated value of the applied load  $W_w$  (at  $\gamma_f = 1.0$ ) for which the slab was tested;
- b) thickness and overall depth of profiled steel sheets;
- c) dimensions and spacing of shear transfer devices;
- d) ultimate tensile strength and yield strength of profiled steel sheets;
- e) dimensions of composite slab;
- f) observed values of concrete cube strengths  $f_{cm}$ ;
- g) load ranges during the dynamic test, e.g.  $0.5 W_w$  to  $1.5 W_w$ ;
- h) load/deflection and load/end slip graphs for the static test;
- i) static load at failure  $W_{st}$ ;
- j) mode of failure of composite slab (flexure, longitudinal slip or vertical shear) and type of failure (ductile or brittle);
- k) applied load capacity  $W_c$ ;
- l) dead weight of composite slab;
- m) the total load carrying capacity of the slab (i.e.  $W_c$  plus dead weight of slab).

## 8.3 Parametric tests

### 8.3.1 General

Separate series of tests should be carried out for different thicknesses, grades and types of profiled steel sheets and for different grades of concrete and slab thickness. The variable in a series of tests should be the shear span  $L_v$  (see 6.4.2).

The tests should encompass the full range of spans required for use in practice. No extrapolation should be made outside this range of spans.

Where stud shear connectors are used to connect the composite slab to the supporting beams, these should be omitted from the test specimens. Their effects as end anchorages should then be covered separately (see 6.4.3).

The mode of failure should be recorded, distinguishing between flexural failure, longitudinal slip and vertical shear failure.

Relative movement (end slip) between the sheets and the concrete at the ends of the test slab should be considered as indicating longitudinal slip. The absence of end slip at failure should be considered as indicating flexural failure with full shear connection.

If the failure mode is vertical shear, the results should not be used for determining values of the empirical parameters  $m_r$  and  $k_r$ .

### 8.3.2 Testing arrangement and procedure

At least two sets of slabs should be tested, each comprising not less than three samples. Testing should be carried out in accordance with 8.2.1 and 8.2.2 except that at least two sets of four concrete cubes will be required. The same nominal compressive cube strength grade of concrete should be used for all tests.

The shape and embossment of the profiled steel sheets should accurately represent the sheets to be used in practice. Tolerances of 5 % on spacing of embossments and 10 % on depth of embossments should be applied.

### 8.3.3 Test results

To establish the design relationship for shear-bond capacity, tests should be carried out on specimens in regions A and B indicated in Figure 12. The maximum experimental shear force  $V_E$  should be taken as half of the value of the failure load  $W_{st}$  as defined in 8.2.2.3 for each test. Only values from tests which resulted in shear-bond failure should be included.

The variables used for the tests should have values such that the parameters  $V_E/(B_s d_s \sqrt{f_{cm}})$  and  $A_p/(B_s L_v \sqrt{f_{cm}})$  for the A and B regions:

- lie within the complete range of values for which a shear-bond type of failure is expected to occur; and
- encompass the actual range of values which are required for use in practice.

For specimens in region A the shear span should be as long as practicable, whilst still producing a shear-bond type of failure. For specimens in region B the shear span should be as short as practicable, whilst still producing a shear-bond type of failure. However, shear spans less than 450 mm should not be used.

The nominal shape and thickness of the profiled steel sheets used for the tests should be the same as those to be used in practice and the value of  $A_p$  should not vary by more than  $\pm 10\%$  between the test specimens. The nominal strength grade of the profiled steel sheets should also be the same as that to be used in practice.

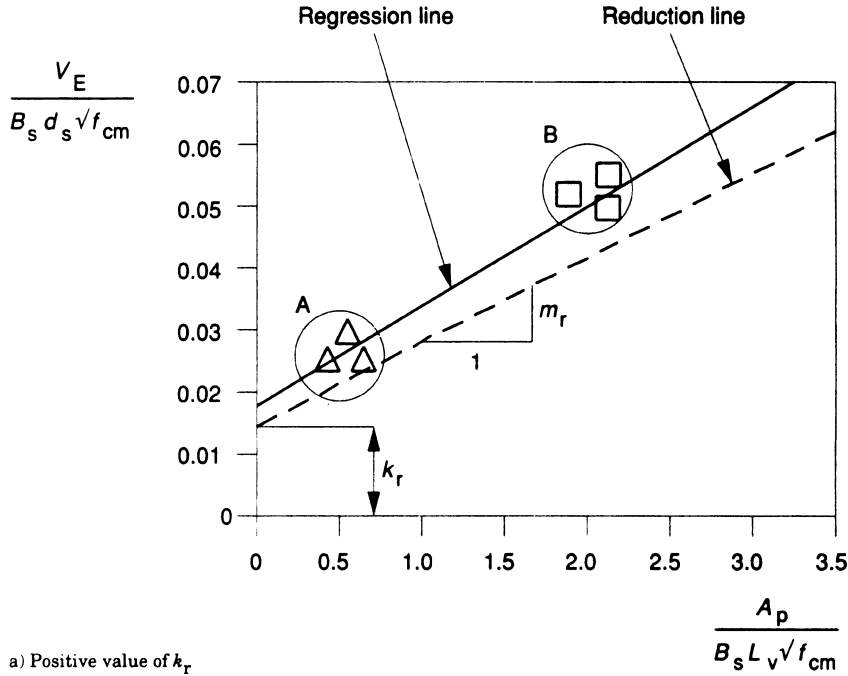

a) Positive value of  $k_r$

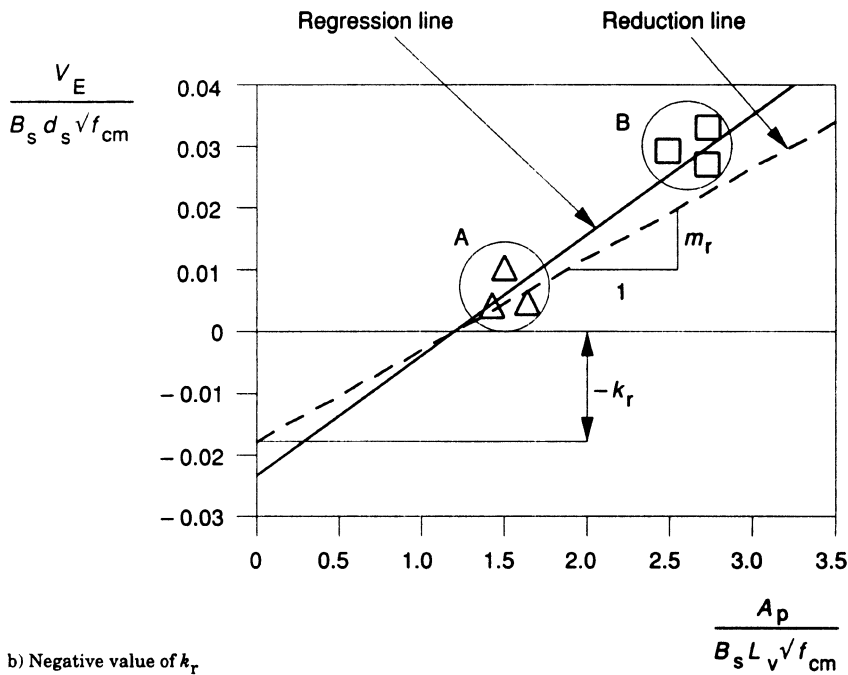

b) Negative value of  $k_r$

**key**

- $A_p$  is the cross-sectional area of the profiled steel sheeting (in  $\text{mm}^2$ );
- $B_s$  is the width of the composite slab (in mm);
- $d_s$  is the effective depth of slab to the centroid of the profiled steel sheets (in mm);
- $f_{cm}$  is the observed concrete cube strength (in  $\text{N/mm}^2$ );
- $k_r$  is an empirical parameter (in  $\text{N/mm}$ );
- $L_v$  is the shear span of the composite slab (in mm), determined in accordance with 6.4.2, but see also 6.2.1;
- $m_r$  is an empirical parameter (in  $\text{N/mm}^2$ ); and
- $V_E$  is the maximum experimental shear force (in N).

**Figure 12 — Shear-bond failure**

The minimum cube strength  $f_{cm}$  of the concrete for the specimens should not be less than  $25 \text{ N/mm}^2$  and the variation between the mean cube strengths of the concrete for the specimens in regions A and B should preferably not exceed  $5 \text{ N/mm}^2$ . Where the variation is greater, the mean cube strength for all the specimens should be used when plotting the test results.

From the tests a regression line should be plotted as shown in Figure 12. The regression line should be taken as the best straight line between the test results in region A and those in region B.

There should be a minimum of three tests in each region, provided that the variation from the mean of the three results is not greater than  $\pm 7.5 \%$ . When the variation is greater than  $\pm 7.5 \%$ , three further tests should be carried out and the six test results should be used to obtain the regression line.

So that the experimental values will generally lie above the line used for design, the values of the empirical parameters  $m_r$  and  $k_r$  for use in design (see 6.4.1) should be determined on the basis of a reduction line, as indicated in Figure 12. Generally the reduction line should be 15 % below the regression line, except that, when eight or more tests are carried out, the reduction line should be taken as 10 % below the regression line.

In the event that the value of the empirical parameter  $k_r$  from the reduction line is negative [see Figure 12 b], the application of the test results to design should be restricted as described in 6.4.1.



# List of references (see 1.2)

## Normative references

### BSI standards publications

BRITISH STANDARDS INSTITUTION, London

BS 476, *Fire tests on building materials and structures.*

BS 476-21:1987, *Methods for determination of the fire resistance of loadbearing elements of construction.*

BS 2989:1992, *Specification for continuously hot-dip zinc coated and iron-zinc alloy coated steel flat products: tolerances on dimensions and shape.*

BS 4449:1988, *Specification for carbon steel bars for the reinforcement of concrete.*

BS 4482:1985, *Specification for cold reduced steel wire for the reinforcement of concrete.*

BS 4483:1985, *Specification for steel fabric for the reinforcement of concrete.*

BS 5493:1977, *Code of practice for protective coating of iron and steel structures against corrosion.*

BS 5950, *Structural use of steelwork in building.*

BS 5950-1:1990, *Code of practice for design in simple and continuous construction: hot rolled sections.*

BS 5950-3, *Design in composite construction.*

BS 5950-3.1:1990, *Code of practice for design of simple and continuous composite construction.*

BS 5950-6, *Code of practice for design of light gauge sheeting, decking and cladding<sup>7)</sup>.*

BS 5950-8:1990, *Code of practice for fire resistant design.*

BS 5975:1982, *Code of practice for falsework.*

BS 6399, *Loading for buildings.*

BS 6399-1:1984, *Code of practice for dead and imposed loads.*

BS 6399-3:1988, *Code of practice for imposed roof loads.*

BS 8110, *Structural use of concrete.*

BS 8110-1:1985, *Code of practice for design and construction.*

BS 8110-2:1985, *Code of practice for special circumstances.*

CP 3, *Code of basic data for the design of buildings.*

CP 3:Chapter V, *Loading.*

CP 3:Chapter V-2:1972, *Wind loads.*

BS EN 10002, *Tensile testing of metallic materials.*

BS EN 10002-1:1990, *Method of test at ambient temperature.*

BS EN 10147:1992, *Specification for continuously hot-dip zinc coated structural steel sheet and strip. Technical delivery conditions.*

## Informative references

### BSI standards publications

BRITISH STANDARDS INSTITUTION, London

BS 5400, *Steel, concrete and composite bridges.*

BS 5400-5:1979, *Code of practice for design of composite bridges.*

BS 5950, *Structural use of steelwork in building.*

BS 5950-9, *Code of practice for stressed skin design<sup>7)</sup>.*

### Other references

[1] CIRIA Technical Note 116. *Design of profiled sheeting as permanent formwork.*

[2] SCI Publication 056. *The fire resistance of composite floors with steel decking.*

[3] CIRIA Special Publication 42. *Fire resistance of composite slabs with steel decking.*

<sup>7)</sup> In preparation.

---

# BSI — British Standards Institution

BSI is the independent national body responsible for preparing British Standards. It presents the UK view on standards in Europe and at the international level. It is incorporated by Royal Charter.

## Revisions

British Standards are updated by amendment or revision. Users of British Standards should make sure that they possess the latest amendments or editions.

It is the constant aim of BSI to improve the quality of our products and services. We would be grateful if anyone finding an inaccuracy or ambiguity while using this British Standard would inform the Secretary of the technical committee responsible, the identity of which can be found on the inside front cover. Tel: 020 8996 9000. Fax: 020 8996 7400.

BSI offers members an individual updating service called PLUS which ensures that subscribers automatically receive the latest editions of standards.

## Buying standards

Orders for all BSI, international and foreign standards publications should be addressed to Customer Services. Tel: 020 8996 9001. Fax: 020 8996 7001.

In response to orders for international standards, it is BSI policy to supply the BSI implementation of those that have been published as British Standards, unless otherwise requested.

## Information on standards

BSI provides a wide range of information on national, European and international standards through its Library and its Technical Help to Exporters Service. Various BSI electronic information services are also available which give details on all its products and services. Contact the Information Centre. Tel: 020 8996 7111. Fax: 020 8996 7048.

Subscribing members of BSI are kept up to date with standards developments and receive substantial discounts on the purchase price of standards. For details of these and other benefits contact Membership Administration. Tel: 020 8996 7002. Fax: 020 8996 7001.

## Copyright

Copyright subsists in all BSI publications. BSI also holds the copyright, in the UK, of the publications of the international standardization bodies. Except as permitted under the Copyright, Designs and Patents Act 1988 no extract may be reproduced, stored in a retrieval system or transmitted in any form or by any means – electronic, photocopying, recording or otherwise – without prior written permission from BSI.

This does not preclude the free use, in the course of implementing the standard, of necessary details such as symbols, and size, type or grade designations. If these details are to be used for any other purpose than implementation then the prior written permission of BSI must be obtained.

If permission is granted, the terms may include royalty payments or a licensing agreement. Details and advice can be obtained from the Copyright Manager. Tel: 020 8996 7070.

BSI  
389 Chiswick High Road  
London  
W4 4AL