

Spacers and chairs for steel reinforcement and their specification —

Part 2: Fixing and application of spacers and chairs and tying of reinforcement

ICS 77.140.99

Committees responsible for this British Standard

The preparation of this British Standard was entrusted by Technical Committee B/525, Building and civil engineering structures, to Subcommittee B/525/2, Structural use of concrete, upon which the following bodies were represented:

Association of Consulting Engineers

British Cement Association

British Precast Concrete Federation Ltd.

Building Research Establishment

Concrete Society Ltd.

Department of the Environment, Transport and the Regions
(Construction Directorate)

Department of the Environment, Transport and the Regions
(Highways Agency)

Institution of Civil Engineers

Institution of Structural Engineers

UK Steel Association

This British Standard, having been prepared under the direction of the Standards Policy and Strategy Committee for Building and Civil Engineering, was published under the authority of the Standards Policy and Strategy Committee and comes into effect on

16 October 2001

© 16 October 2001

The following BSI references relate to the work on this standard:

Committee reference B/525/2

Draft for comment 00/104696 DC

Amendments issued since publication

Amd. No.	Date	Comments

ISBN 0 580 38557 4

Contents

	Page
Committees responsible	Inside front cover
Foreword	ii
<hr/>	
1 Scope	1
2 Normative references	1
3 Terms and definitions	1
4 Designations and symbols	1
5 Tying of steel reinforcement	2
6 General requirements for spacers and chairs	2
7 Spacers and chair categories and applications	3
8 Spacing of spacers and chairs	3
<hr/>	
Bibliography	16
<hr/>	
Figure 1 — Spacers for bottom reinforcement in slabs	4
Figure 2 — Continuous chairs for top reinforcement in slabs with bottom reinforcement	5
Figure 3 — Chairs for top reinforcement in slabs without bottom reinforcement	6
Figure 4 — Circular chairs for top reinforcement in slabs with bottom reinforcement	7
Figure 5 — Spacers for slab edges	9
Figure 6 — Spacers for ribbed slabs	10
Figure 7 — Spacers for beams	12
Figure 8 — Spacers for columns	13
Figure 9 — Continuous chairs for walls	15
<hr/>	
Table 1 — Applications for spacers and chairs in terms of category	3
<hr/>	

Foreword

This British Standard has been prepared by Technical Committee B/525/2. It is the first edition of the standard.

Until now the inadequate manufacture and use of spacers and chairs and method of tying has been a major cause of misplaced steel reinforcement resulting in decreased durability of reinforced concrete. In November 1989 the Concrete Society published *Spacers for reinforced concrete* (CS101) [1] providing recommendations for achieving cover but until now no British Standard has existed.

All British Standards for reinforced concrete design and construction (e.g. BS 8110-1, BS 5400-7 and BS 8007) state that the nominal cover specified applies to all reinforcement including links.

This British Standard gives standardized methods of achieving the specified nominal cover. It is based on the relevant parts of Concrete Society Report CS101 *Spacers* [1] published in November 1989 and was developed to be consistent with the Comité Euro-International du Béton Bulletin d'Information No. 201 *Spacers, chairs and tying of steel reinforcement* [2].

It is imperative that chairs and spacers conforming to BS 7973-1 are applied in accordance with BS 7973-2.

However, the need to check cover before concrete placement and maintaining it whilst placing and compacting the concrete is extremely important.

Where the specified cover cannot be achieved the instructions of the designer should be obtained.

Abnormal loads, such as those exerted by construction plant, storage of materials and heavy reinforcement cages, can overload spacers and chairs. Under abnormal load conditions adequate support is most suitably achieved using heavy (H) category line spacers at centres which depend on the exact size and nature of the load.

A British Standard does not purport to include all necessary provisions of a contract. Users of British Standards are responsible for their correct application.

Compliance with a British Standard does not of itself confer immunity from legal obligations.

Summary of pages

This document comprises a front cover, an inside front cover, pages i and ii, pages 1 to 16, an inside back cover and a back cover.

The BSI copyright notice displayed throughout this document indicates when the document was last issued.

1 Scope

This part of this British Standard specifies fixing and application requirements for spacers and chairs sufficient to achieve and maintain cover to reinforcement in in situ reinforced concrete members subject to normal construction loads. Application requirements include tying and spacing.

This British Standard applies to all types of reinforcement conforming to BS 4449 and BS 4482 and some types of welded fabric conforming to BS 4483, supplied to the preferred shapes and tolerances given in BS 8666.

Other important aspects such as clear and unambiguous detailing, the need to consider buildability, formwork tolerances and reinforcement are not specified. Standards of workmanship and supervision are also outside the scope of this British Standard as is a means of resisting wind loads or enabling the lifting of prefabricated reinforcement cages.

NOTE 1 Where appropriate, the basic principles can be applied to precast concrete or proprietary systems.

NOTE 2 Straight reinforcement for curvilinear members to be formed to a radius exceeding the maximum radius of bending given in BS 8666 may require extra tying and support to resist additional loads caused by the springing effect of the bars.

2 Normative references

The following normative documents contain provisions which, through reference in this text, constitute provisions of this part of this British Standard. For dated references, subsequent amendments to, or revisions of, any of these publications do not apply. For undated references, the latest edition of the publication referred to applies.

BS 4449, *Specification for carbon steel bars for the reinforcement of concrete.*

BS 4482, *Specification for cold reduced steel wire for the reinforcement of concrete.*

BS 4483, *Specification of steel fabric for the reinforcement of concrete.*

BS 7973-1:2001, *Spacers and chairs for steel reinforcement and their specification — Part 1: Product performance requirements.*

BS 8666, *Specification for scheduling, dimensioning, bending and cutting of steel reinforcement for concrete.*

3 Terms and definitions

For the purposes of this British Standard the terms and definitions given in BS 7973-1 and the following apply.

3.1

tying wire

wire used to fix reinforcement, spacers and chairs and which is normally 16 gauge black annealed wire

NOTE Corrosion resistant wire of equal strength may, where considered appropriate, be used.

4 Designations and symbols

The following designations and symbols are used throughout this British Standard.

- | | |
|----------|---|
| <i>c</i> | Cover or nominal cover (the nominal cover specified on the structural design drawings). |
| <i>d</i> | The nominal size of the bar nearest the surface of the concrete including links, used to determine the frequency of spacers along the bar to which they are fixed. For the spacing of chairs, <i>d</i> is the nominal size of the bar or wire that the chair is supporting. |
| <i>D</i> | The nominal size of the main bar. |

5 Tying of steel reinforcement

5.1 General

5.1.1 Reinforcement shall be tied together to prevent displacement of bars. The spacing of ties for slabs, beams, columns, foundations and walls shall be in accordance with **5.2**, **5.3**, **5.4**, **5.5** and **5.6**.

5.1.2 Care shall be taken to ensure that projecting ends of tying wire do not encroach into the concrete cover.

5.2 Tying within slabs

Perimeter bars shall be tied at every intersection. For bars up to and including 20 mm, alternate intersections shall be tied. Reinforcement at right angles to the edge of the slab shall be fixed by locating the bar with the specified end cover and tying it from that end inward.

NOTE Where all bars are 25 mm or larger they may be tied at greater than alternate intersections but not exceeding 50 times the size of the smallest bars.

5.3 Tying within beams

Every intersection of a corner of a link with a longitudinal main bar shall be tied. Other bars within the links shall be tied at $50D$ centres. Where welded fabric is used as a link cage, it shall be tied at $50D$ centres to the main bars. Each set of multiple links shall be tied together.

5.4 Tying within columns

Because of the importance of keeping the main vertical bars in their correct position, every intersection between vertical bars and links shall be tied. For link cages made of welded fabric the vertical wires shall be tied at $50D$ centres to the main bars. Each set of multiple links shall be tied together.

5.5 Tying within foundations

The horizontal part of starter bars shall be tied at every intersection with the foundation reinforcement at right angles to the starter bars and any bars parallel to it. The vertical part of the starter bar shall be tied at every intersection with any column links within the foundation.

5.6 Tying within walls

Perimeter bars shall be tied at every intersection. For bars up to and including 20 mm, alternate intersections shall be tied. Reinforcement at right angles to the end of a wall shall be fixed by locating the bar with the specified end cover and tying it from that end inward.

NOTE Where all bars are 25 mm or larger they may be tied at greater alternate intersections but not exceeding 50 times the size of the smallest bars.

6 General requirements for spacers and chairs

6.1 Cover shall be achieved by using factory made spacers and chairs manufactured according to BS 7973-1, to support and locate reinforcement during the construction of reinforced concrete elements. Reinforcement shall be adequately tied (see clause **5**) together to prevent displacement of bars. The number and position of spacers shall be as given in clause **8**.

6.2 The requirements for beams and slabs shall apply to their equivalent foundation members, such as ground beams, ground slabs, strip footings, individual bases and pile caps, provided the reinforcement is supported off concrete blinding and is not subject to abnormal loads.

6.3 A spacer or chair shall maintain the reinforcement in the position specified on the structural design drawings during concrete placing and shall not significantly reduce the durability of the structure.

6.4 Spacers shall be fixed to the links, fabric or reinforcement nearest the face of the concrete to which the cover is specified.

6.5 If coloured, textured, profiled or exposed aggregate finishes to the concrete are required, spacers shall be selected so that they do not disrupt the aesthetic appearance of the concrete.

NOTE Where a concrete element has only one face with a special finish, disruption of its appearance can be avoided by spacing the reinforcement off either the opposite face or by the use of chairs.

6.6 Spacers with a suitable bearing area shall be used where cover is required between reinforcement and materials subject to indentation or puncture, such as some void formers, impermeable membranes and insulation materials.

6.7 When steel chairs are required to support reinforcement off an exposed face, the ends of each chair leg shall be encased in a protective tip, such as a closed plastics sleeve, for a distance of at least 40 mm.

7 Spacers and chair categories and applications

Spacer and chair categories required for particular applications shall be in accordance with Table 1. Criteria for assessing the spacer category shall be in accordance with BS 7973-1:2001, Table 2.

Table 1 — Applications for spacers and chairs in terms of category

Spacer and chair category	Application
Light (L)	To provide cover in vertical members to the reinforcement nearest the surface of the concrete or to horizontal reinforcement in small sections not subject to any foot traffic. Not suitable for reinforcement greater than 16 mm in size.
Normal (N)	To provide cover to reinforcement where the size of reinforcement is 20 mm or less.
Heavy (H)	To provide cover to reinforcement where the size of reinforcement is greater than 20 mm.
Chairs (C)	To support to the top reinforcement in slabs, so as to provide the required top cover or to separate layers of reinforcement.

8 Spacing of spacers and chairs

8.1 Spacers and chairs within slabs

8.1.1 *Solid slabs*

8.1.1.1 *Bottom face*

All bar reinforcement nearest to the bottom face shall be supported by spacers at centres not exceeding $50d$ and not exceeding 1 000 mm. Spacers shall be staggered [see Figure 1a)]. Fabric shall be supported by spacers at centres not exceeding 500 mm in two directions at right angles [see Figure 1b)].

8.1.1.2 *Top face*

Top reinforcement shall always be supported off the bottom reinforcement where such reinforcement exists, by continuous chairs (see Figure 2).

Where there is no bottom reinforcement, the top reinforcement shall be supported from the formwork or blinding by the use of individual chairs at centres not exceeding $50d$, fitted with protective tips, or by continuous chairs at centres not exceeding $50d$ resting on line spacers [see Figure 3a) and Figure 3b)].

In all cases, continuous chairs supporting individual bars shall provide a line of support to groups of adjacent bars at centres not exceeding $50d$ the size of bar they are supporting.

The spacing of individual chairs shall not exceed $50d$ centres in both directions for individual bars, or 500 mm for welded fabric.

Fabric shall be supported by continuous chairs at centres not exceeding 500 mm resting on line spacers, or by individual chairs at centres not exceeding 500 mm. Individual chairs shall be fitted with protective tips.

Alternatively, top fabric shall be supported off a bottom layer by 570 mm diameter circular chairs with their centres at each apex of an equilateral triangle of side 1 200 mm [i.e. 1 200 mm centres in one direction and 1 040 mm in the direction at right angles and with rows staggered (see Figure 4)]. The ends of circular chairs shall be lapped at least 200 mm. Circular chairs shall not be used for foot traffic if either the main or the cross wires in the fabric they are supporting are less than 7 mm in size. Circular chairs shall each be tied at least twice to each of the bottom and top layers of fabric. For all fabrics the ties shall be placed wherever node points in the fabric and the chair coincide.

NOTE These spacings are for A393 to A193 and B1131 to B385 fabric conforming to BS 4483.

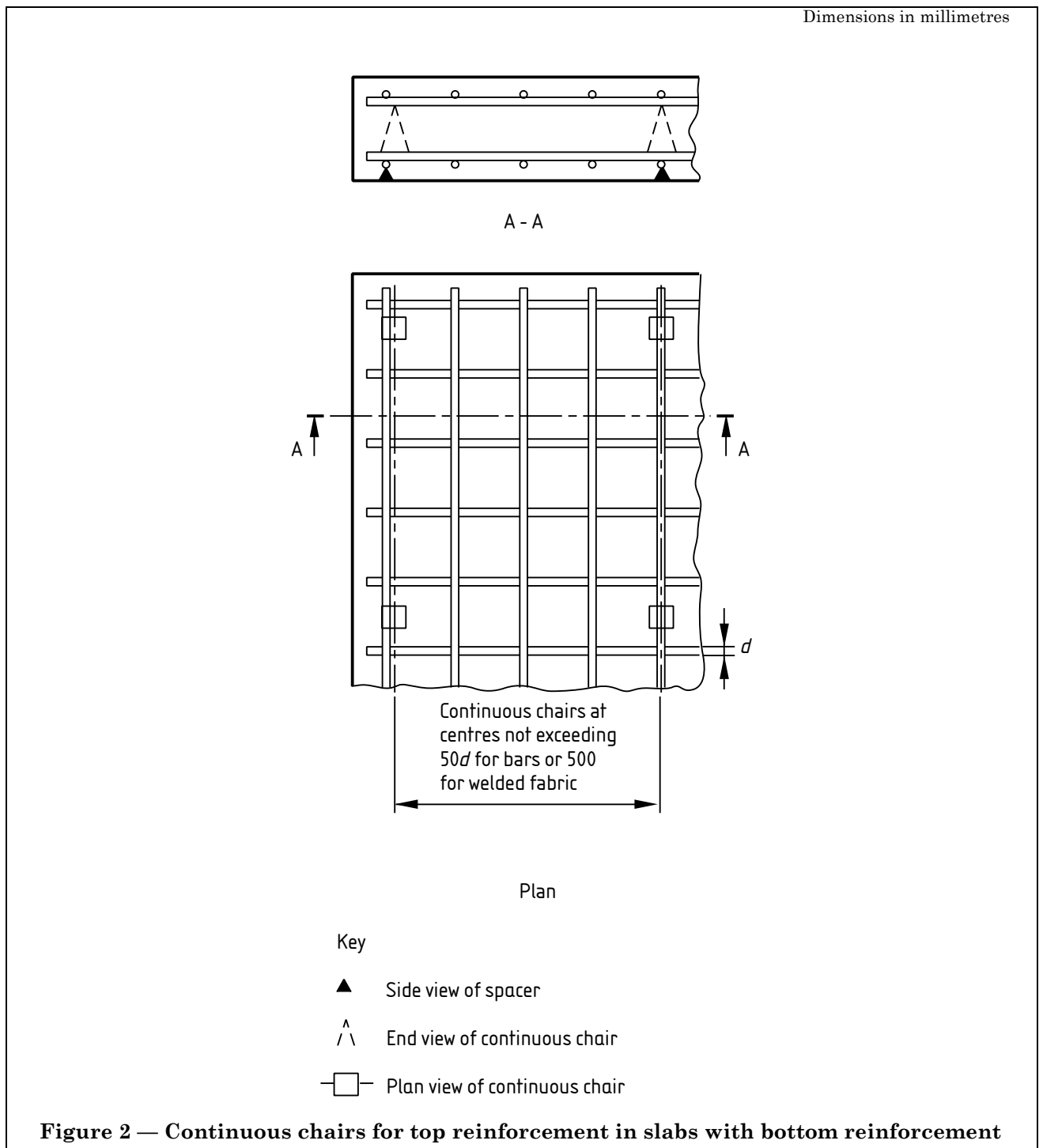

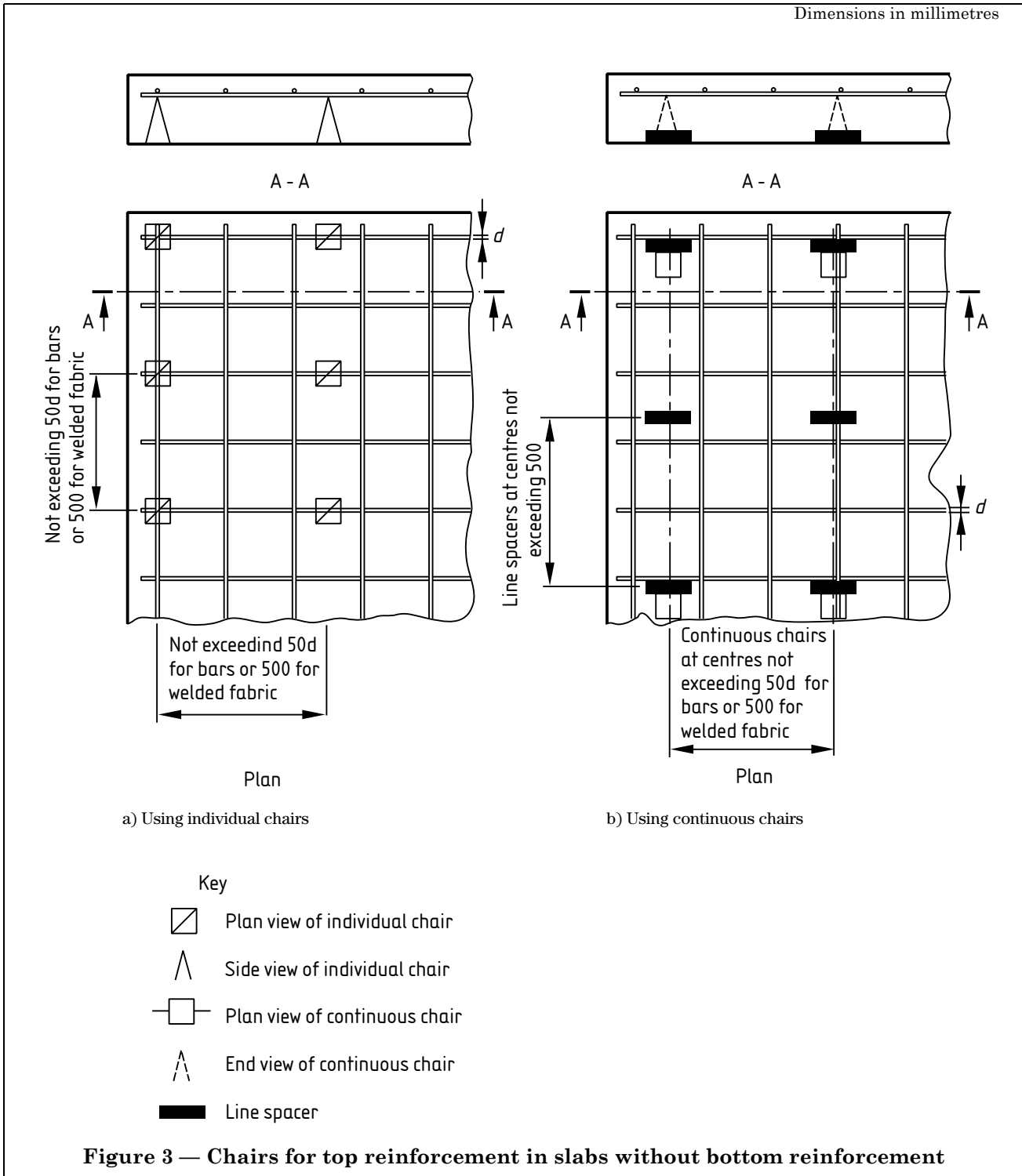

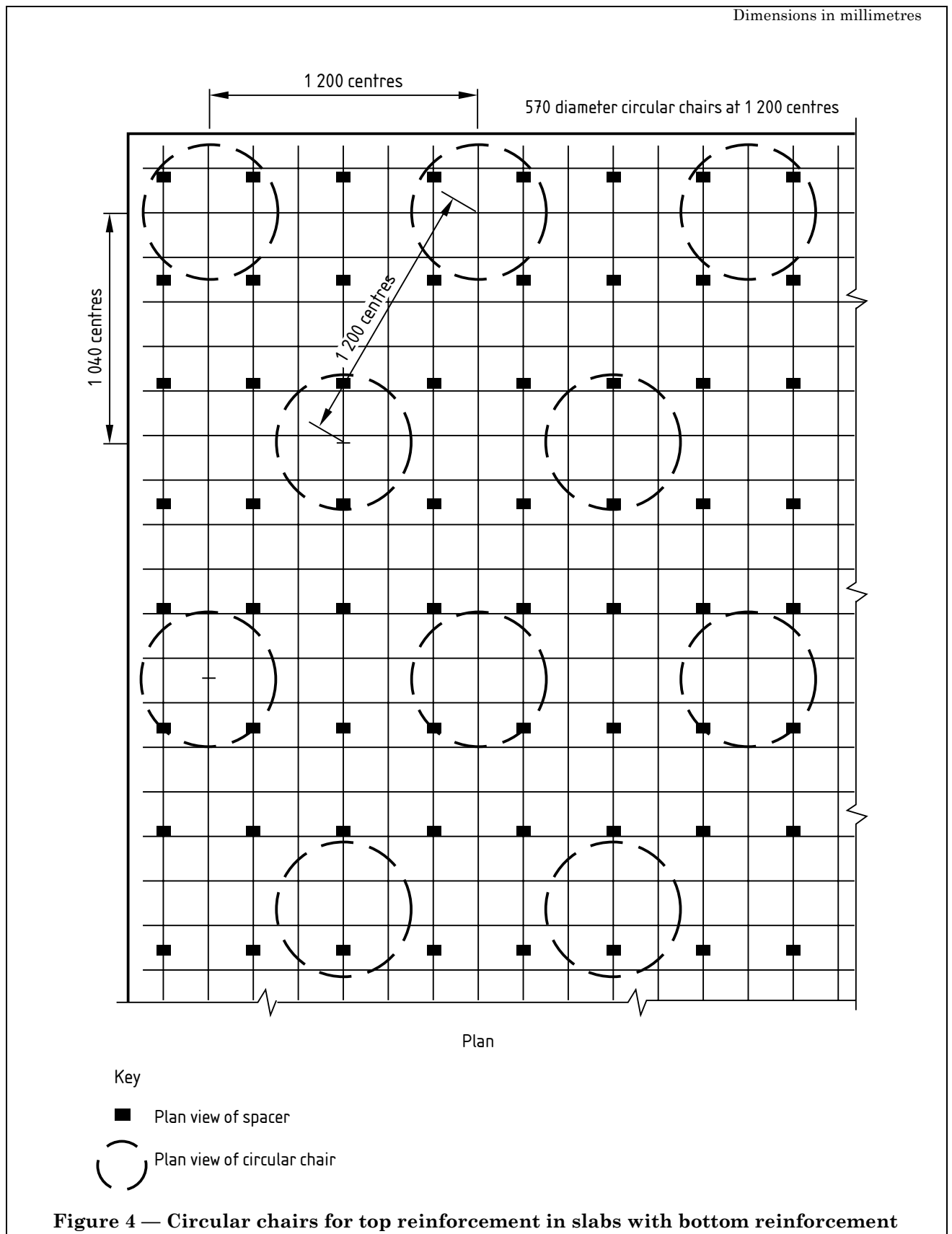

8.1.1.3 *Edge face*

8.1.1.3.1 *Vertical reinforcement*

Vertical reinforcement, i.e. reinforcement at right angles to the top and bottom surfaces of the slab (including bent bars), shall be tied at every intersection and have spacers on every other vertical bar [see Figure 5a)].

8.1.1.3.2 *Horizontal reinforcement parallel to the edge of the slab*

Horizontal reinforcement, parallel to the edge of the slab, shall be tied at every other intersection and shall have spacers at centres not exceeding $50d$ and not exceeding 1 000 mm centres on each bar [see Figure 5b)].

8.1.1.3.3 *Horizontal reinforcement at right angles to the edge of the slab*

For horizontal reinforcement at right angles to the edge of the slab, end spacers shall be fixed on the ends of straight bars when there is an absence of other reinforcement to which to tie the slab reinforcement. In such cases, end spacers shall be provided at centres not exceeding 1 000 mm.

8.1.2 *Hollow pot, waffle, trough and ribbed slabs*

8.1.2.1 Where main bars are supported by links in the ribs of hollow pot, waffle, trough and ribbed slabs (see Figure 6) spacers shall be fixed to the links at centres not exceeding 1 000 mm along the rib.

8.1.2.2 On each link three spacers shall be fixed: one at mid-height on each of the two vertical legs and one on the horizontal part of the link in the centre. Where the main bars are not supported by links, rib spacers shall be fixed to the main bars at centres not exceeding $50D$ and not exceeding 1 000 mm. Spacers to reinforcement in topping and in solid areas shall be in accordance with 8.1.1 or 8.1.3.

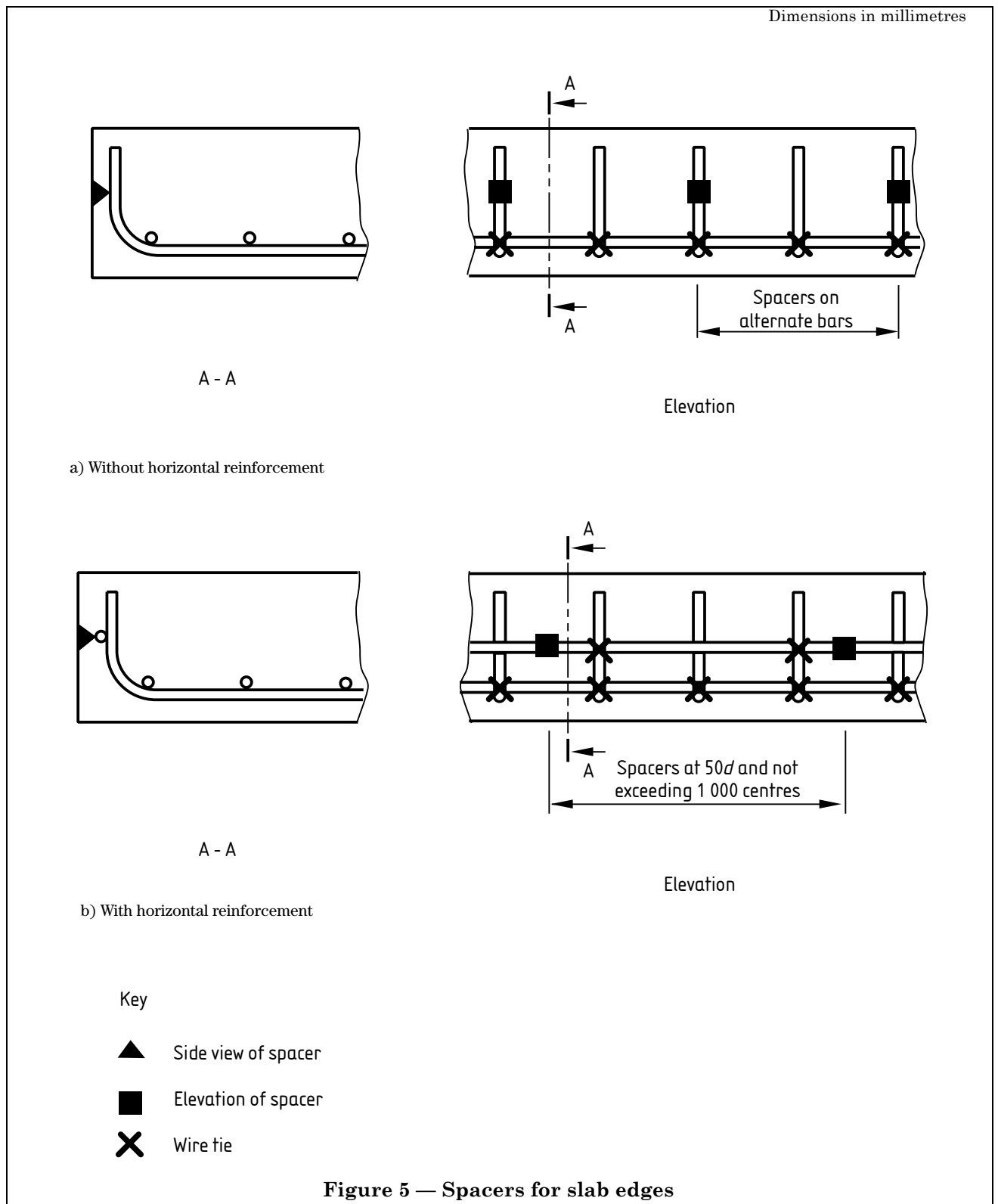

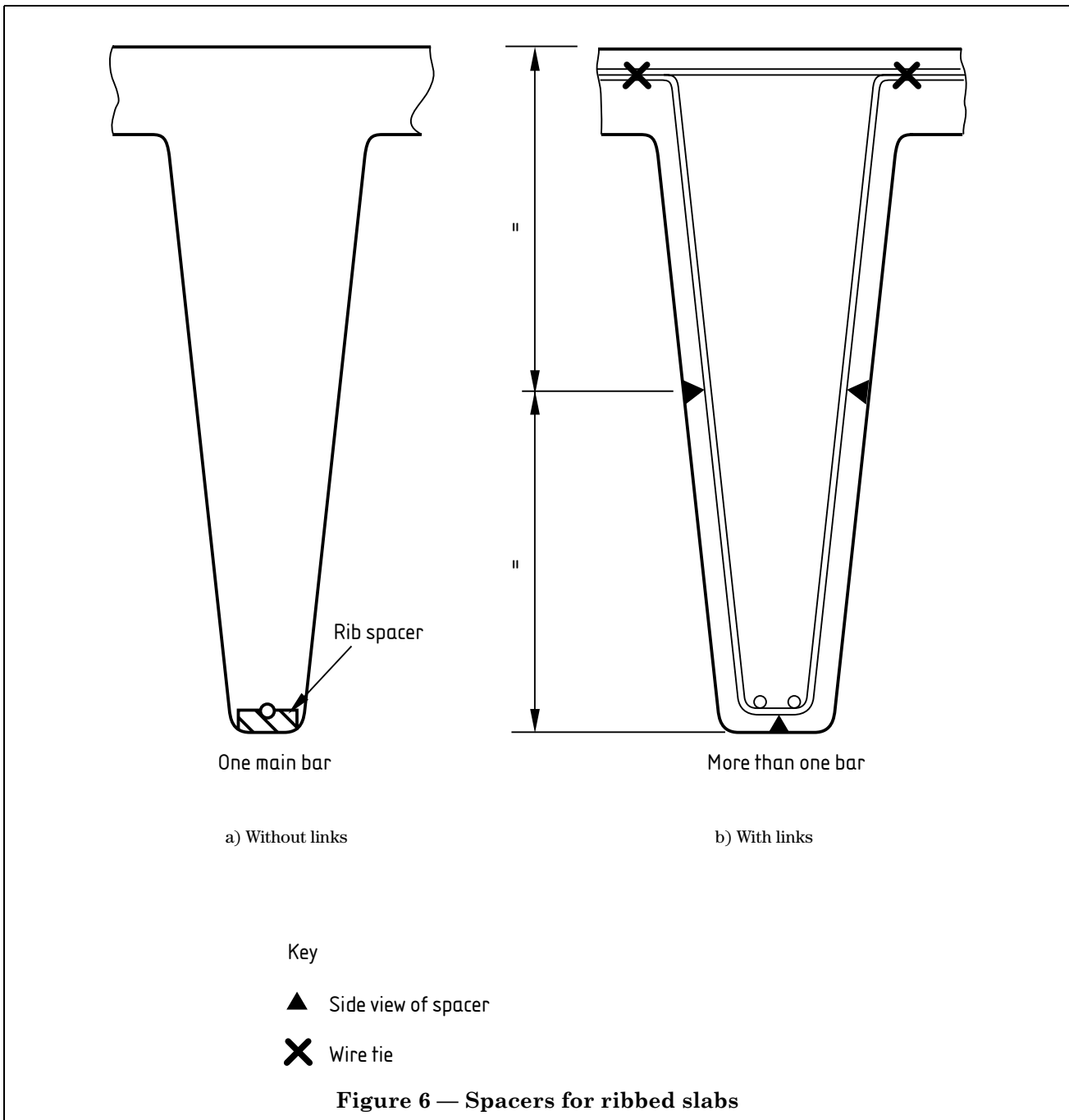

8.1.3 Cantilevers

8.1.3.1 Top reinforcement in cantilevers shall be located by the use of chairs except where the main reinforcement is specifically designed to be self supporting. At the point where the cantilever joins the main structure, continuous chairs shall be provided to support the top reinforcement with the centres of successive chairs along the bar being at centres not exceeding $50d$ and not exceeding 1 000 mm.

NOTE The chairs, in addition to maintaining cover, also position the top reinforcement.

8.1.3.2 In the case of solid slab cantilevers the top reinforcement shall be supported by continuous chairs resting on bottom reinforcement, where it exists.

8.1.3.3 Where there is no bottom reinforcement, top reinforcement shall be supported from the formwork by the use of chairs with protective tips, or by continuous chairs resting on line spacers.

8.2 Spacers within beams

8.2.1 General

The links or fabric to which the spacers are attached shall be at the ends of the beam and at centres not exceeding 1 000 mm along the beam [see Figure 7a)]. Spacers shall be fixed on three faces of the same link in accordance with 8.2.2, 8.2.3 and 8.2.4.

8.2.2 Bottom face

Requirements for the bottom face shall be as follows.

- a) For narrow beams (less than 250 mm wide), one spacer shall be positioned in the middle of the bottom leg of the link [see Figure 7b)].
- b) For normal beams (between 250 mm and 500 mm wide), two spacers shall be positioned within 50 mm of the ends of the straight portion and not on the curved part of the bottom leg of the link [see Figure 7c)].

For wide beams (greater than 500 mm wide), two spacers shall be positioned within 50 mm of the ends of the straight portion and not on the curved part of the bottom leg of the link [see Figure 7e)].

NOTE Additional spacers may need to be provided so that the distance between them does not exceed $50d$.

Where multiple links overlap, they shall be provided with an additional spacer positioned immediately adjacent to the vertical leg of one of the links but not on the curved part of the link.

8.2.3 Side face

For narrow and normal beams, one spacer shall be provided on each vertical leg of the link at the mid-height of the beam. For deep beams (greater than $100d$ deep), spacers shall be provided at centres not exceeding $50d$ [see Figure 7d)]. Spacers on each side of the beam shall be at the same level above the soffit.

8.2.4 End face

Every end termination of a bar at an exposed concrete face shall have a spacer [see Figure 7a)].

NOTE Longitudinal bars may terminate in one of two different ways, i.e. either with an end anchorage or as a straight bar.

8.3 Spacers within columns

Links to which the spacers are attached shall be at the top, middle and bottom of each lift of concrete, and at centres not exceeding $100D$ [see Figure 8a)]. Spacers shall be placed on all sides of the same link according to the following criteria.

- a) For small (sides not exceeding $50d$), square or rectangular columns, spacers shall be positioned on the two shortest sides in the middle of the link. Two spacers shall be provided on each of the other two sides positioned within 50 mm of the ends of the straight portion, not the curved part of the link, i.e. six spacers in total per link, [see Figure 8b)].
- b) For wide (sides exceeding $50d$) columns, two spacers shall be positioned within 50 mm of the ends of the straight portion of the link and not on the curved part of the link. Intermediate spacers shall be provided so that the distance between spacers does not exceed $50d$. Where the shorter sides of the wide columns do not exceed $50d$, spacers shall be provided in the middle of the link on these sides [see Figure 8c)].
- c) Columns containing multiple links shall be provided with an additional spacer positioned immediately adjacent to the inner leg of one of the links but not on the curved part of each link. Each set of multiple links shall be tied together [see Figure 8d)].
- d) Links with spacers in circular columns shall have at least four equally spaced spacers per link (one pitch for a helix) with the distance between them not exceeding $50d$, measured along the link [see Figure 8e)].
- e) Multifaceted columns shall contain at least one spacer per facet. Facets exceeding $50d$ shall have two spacers positioned within 50 mm of the ends of the straight part of the link and not on the curved part of the link. Intermediate spacers shall be provided so that the distance between each spacer does not exceed $50d$ [see Figure 8f)].
- f) Spiral links shall have the same requirements as circular columns [see d)].

NOTE Requirements a) to f) apply to all main cross-sectional shapes of columns, i.e. square, rectangular, circular and multifaceted.

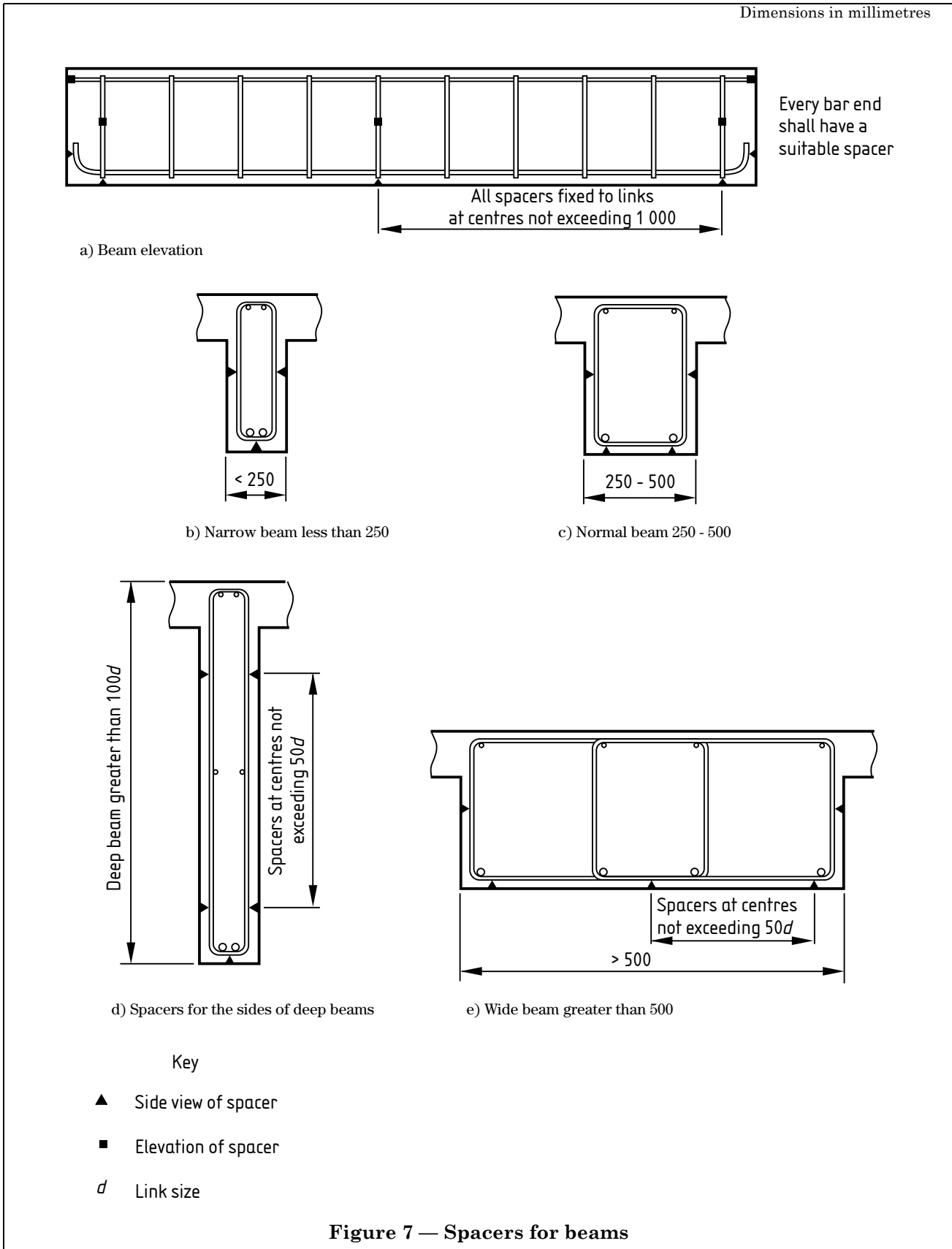

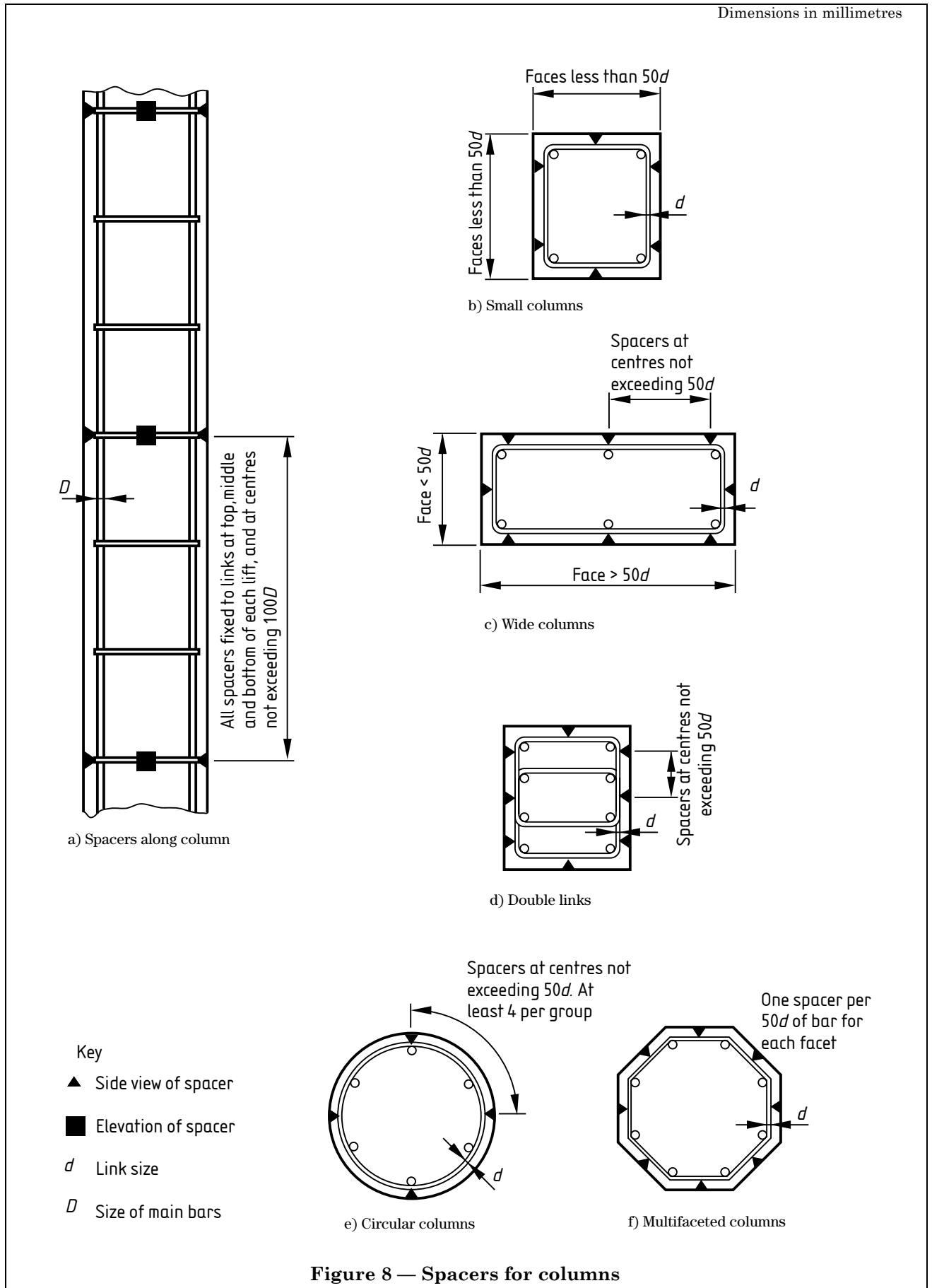

Figure 8 — Spacers for columns

8.4 Spacers and chairs within foundations

The requirements for reinforced strip footings, individual bases, ground beams, ground slabs and pile caps shall be the same as those for suspended slabs and beams (see 8.1 and 8.2).

8.5 Spacers and chairs within walls

For bars or fabric, face cover shall be maintained by spacers on the reinforcement nearest to the face, in two directions at right angles, at centres not exceeding $50d$ or 500 mm, whichever is the greater, and staggered. Spacers on opposite faces shall be coincident when viewed in elevation. Fabric or bars on opposing faces in walls up to 400 mm thick shall be separated by rows of continuous chairs (preferably vertical) at centres not exceeding 1 000 mm and located at the same positions as the spacers. (See Figure 9).

For horizontal reinforcement perpendicular to the end of the wall, end spacers shall be provided on the ends of straight bars when there is an absence of other reinforcement to which to tie the wall reinforcement. In such cases, end spacers shall be provided at centres not exceeding 1 000 mm (see Figure 9).

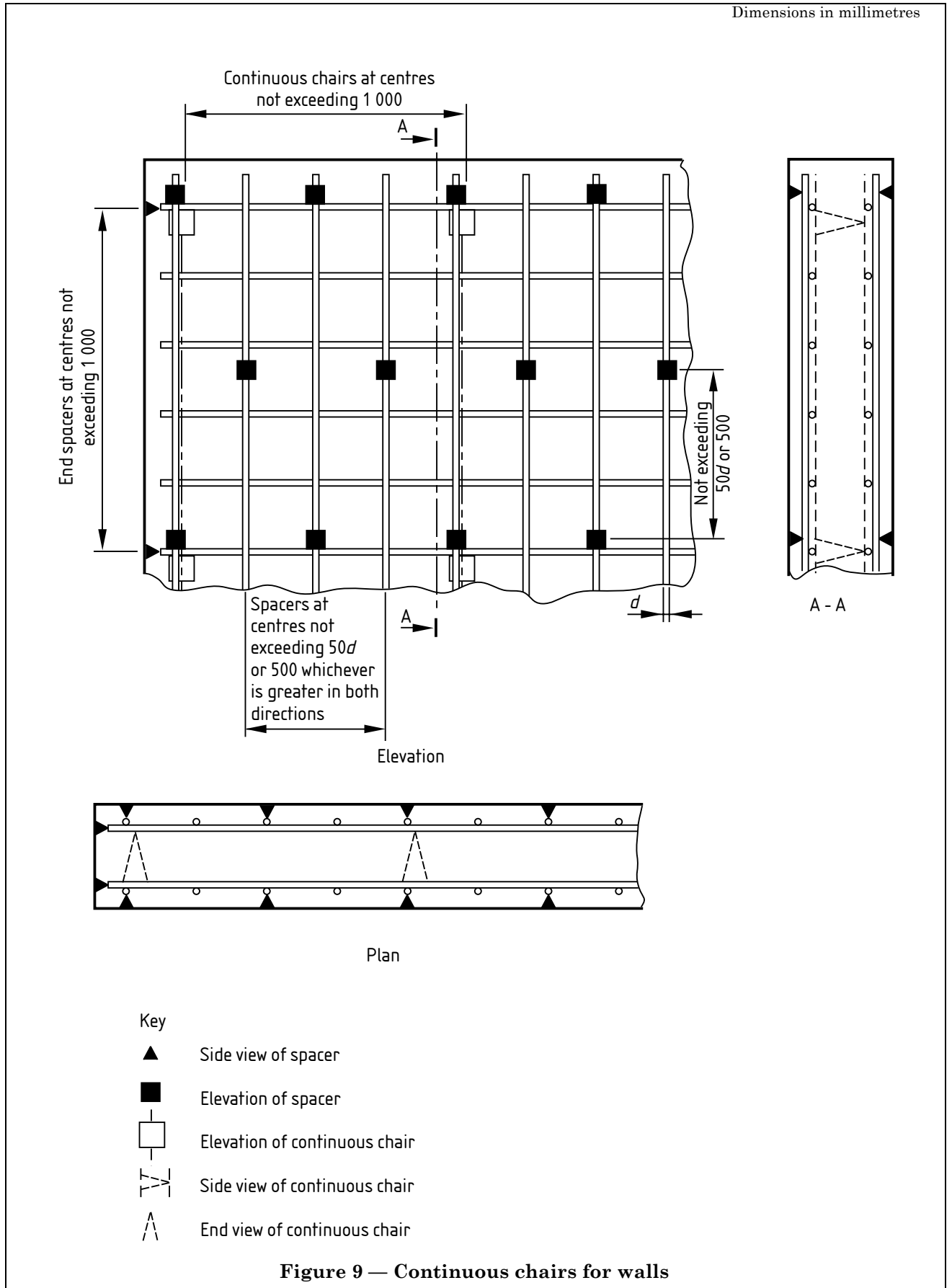

Bibliography

Standards publications

BS 5400-7:1978, *Steel concrete and composite bridges — Part 7: Specification for materials and workmanship, concrete reinforcement and prestressing tendons.*

BS 8110-1:1997, *Structural use of concrete — Part 1: Code of practice for design and construction.*

BS 8007:1987, *Code of practice for design of concrete structures for retaining aqueous liquid.*

Other documents

[1] CONCRETE SOCIETY. *Spacers for reinforced concrete.* Crowthorne [Berkshire]: Concrete Society, 1989 Report CS101¹⁾.

[2] COMITÉ EURO-INTERNATIONAL DU BÉTON. *Bulletin d'Information No. 201 — Spacers, chairs and tying of steel reinforcement.* Lausanne: Comité Euro-International du Béton, 1990²⁾.

¹⁾ Available from: The Concrete Society, Century House, Telford Way, Crowthorne, Berks RG45 2YS.

²⁾ Available from: Comité Euro-International du Béton, Office DGC-A2-424, Swiss Federal Institute of Technology Lausanne (EPFL), Case Postal 88, CH-1015 Lausanne, Switzerland.

blank

BSI — British Standards Institution

BSI is the independent national body responsible for preparing British Standards. It presents the UK view on standards in Europe and at the international level. It is incorporated by Royal Charter.

Revisions

British Standards are updated by amendment or revision. Users of British Standards should make sure that they possess the latest amendments or editions.

It is the constant aim of BSI to improve the quality of our products and services. We would be grateful if anyone finding an inaccuracy or ambiguity while using this British Standard would inform the Secretary of the technical committee responsible, the identity of which can be found on the inside front cover. Tel: 020 8996 9000. Fax: 020 8996 7400.

BSI offers members an individual updating service called PLUS which ensures that subscribers automatically receive the latest editions of standards.

Buying standards

Orders for all BSI, international and foreign standards publications should be addressed to Customer Services. Tel: 020 8996 9001. Fax: 020 8996 7001. Standards are also available from the BSI website at <http://www.bsi-global.com>.

In response to orders for international standards, it is BSI policy to supply the BSI implementation of those that have been published as British Standards, unless otherwise requested.

Information on standards

BSI provides a wide range of information on national, European and international standards through its Library and its Technical Help to Exporters Service. Various BSI electronic information services are also available which give details on all its products and services. Contact the Information Centre. Tel: 020 8996 7111. Fax: 020 8996 7048.

Subscribing members of BSI are kept up to date with standards developments and receive substantial discounts on the purchase price of standards. For details of these and other benefits contact Membership Administration. Tel: 020 8996 7002. Fax: 020 8996 7001. Further information about BSI is available on the BSI website at <http://www.bsi-global.com>.

Copyright

Copyright subsists in all BSI publications. BSI also holds the copyright, in the UK, of the publications of the international standardization bodies. Except as permitted under the Copyright, Designs and Patents Act 1988 no extract may be reproduced, stored in a retrieval system or transmitted in any form or by any means – electronic, photocopying, recording or otherwise – without prior written permission from BSI.

This does not preclude the free use, in the course of implementing the standard, of necessary details such as symbols, and size, type or grade designations. If these details are to be used for any other purpose than implementation then the prior written permission of BSI must be obtained.

If permission is granted, the terms may include royalty payments or a licensing agreement. Details and advice can be obtained from the Copyright Manager. Tel: 020 8996 7070.

BSI
389 Chiswick High Road
London
W4 4AL