

Products and systems for the protection and repair of concrete structures — Test methods — Determination of tensile strength development for polymers

The European Standard EN 1543:1998 has the status of a
British Standard

ICS 91.080.40; 91.100.30

NO COPYING WITHOUT BSI PERMISSION EXCEPT AS PERMITTED BY COPYRIGHT LAW



S

National foreword

This British Standard is the English language version of EN 1543:1998. No existing standard is superseded.

The UK participation in its preparation was entrusted by Technical Committee B/517, Concrete, to Subcommittee B/517/8, Repair and protection of concrete structures, which has the responsibility to:

- aid enquirers to understand the text;
- present to the responsible European committee any enquiries on the interpretation, or proposals for change, and keep the UK interests informed;
- monitor related international and European developments and promulgate them in the UK.

A list of organizations represented on this subcommittee can be obtained on request to its secretary.

Cross-references

The British Standards which implement international or European publications referred to in this document may be found in the BSI Standards Catalogue under the section entitled "International Standards Correspondence Index", or by using the "Find" facility of the BSI Standards Electronic Catalogue.

A British Standard does not purport to include all the necessary provisions of a contract. Users of British Standards are responsible for their correct application.

Compliance with a British Standard does not of itself confer immunity from legal obligations.

Summary of pages

This document comprises a front cover, an inside front cover, the EN title page, pages 2 to 7 and a back cover.

This British Standard, having been prepared under the direction of the Sector Committee for Building and Civil Engineering, was published under the authority of the Standards Committee and comes into effect on 15 November 1998

© BSI 1998

ISBN 0 580 29765 9

Amendments issued since publication

| Amd. No. | Date | Text affected |
|----------|------|---------------|
| | | |
| | | |
| | | |
| | | |
| | | |

EUROPEAN STANDARD

EN 1543

NORME EUROPÉENNE

EUROPÄISCHE NORM

January 1998

ICS 91.080.40

Descriptors: Concrete structures, repairs, protection, materials, polymers, materials, polymers, epoxy resins, products for concrete construction, tests, determination, tensile strength, hardening

English version

Products and systems for the protection and repair of concrete structures — Test methods — Determination of tensile strength development for polymers

Produits et systèmes pour la protection et la réparation des structures en béton — Méthodes d'essais — Détermination du développement de la résistance en traction des polymères

Produkte und Systeme für den Schutz und die Instandsetzung von Betontragwerken — Prüfverfahren — Bestimmung der Zugfestigkeitsentwicklung von Polymeren

This European Standard was approved by CEN on 20 December 1997.

CEN members are bound to comply with the CEN/CENELEC Internal Regulations which stipulate the conditions for giving this European Standard the status of a national standard without any alteration.

Up-to-date lists and bibliographical references concerning such national standards may be obtained on application to the Central Secretariat or to any CEN member.

This European Standard exists in three official versions (English, French, German). A version in any other language made by translation under the responsibility of a CEN member into its own language and notified to the Central Secretariat has the same status as the official versions.

CEN members are the national standards bodies of Austria, Belgium, Denmark, Finland, France, Germany, Greece, Iceland, Ireland, Italy, Luxembourg, Netherlands, Norway, Portugal, Spain, Sweden, Switzerland and United Kingdom.

CEN

European Committee for Standardization
Comité Européen de Normalisation
Europäisches Komitee für Normung

Central Secretariat: rue de Stassart 36, B-1050 Brussels

© 1998 CEN All rights of exploitation in any form and by any means reserved worldwide for CEN national Members.

Ref. No. EN 1543:1998 E

Foreword

This European Standard has been prepared by Technical Committee CEN/TC 104, Concrete (performance, production, placing and compliance criteria), the secretariat of which is held by DIN.

This European Standard shall be given the status of a national standard, either by publication of an identical text or by endorsement, at the latest by July 1998, and conflicting national standards shall be withdrawn at the latest by July 1998.

According to the CEN/CENELEC Internal Regulations, the national standards organizations of the following countries are bound to implement this European Standard: Austria, Belgium, Czech Republic, Denmark, Finland, France, Germany, Greece, Iceland, Ireland, Italy, Luxembourg, Netherlands, Norway, Portugal, Spain, Sweden, Switzerland and United Kingdom.

Contents

| | Page |
|---|------|
| Foreword | 2 |
| 1 Scope | 3 |
| 2 Test principle | 3 |
| 3 General requirements for testing | 3 |
| 3.1 Laboratory | 3 |
| 3.2 Apparatus | 3 |
| 3.3 Materials | 3 |
| 4 Test procedure for the determination of the development of strength | 6 |
| 4.1 Preparation of the resin | 6 |
| 4.2 Mixing | 6 |
| 4.3 Preparation of the moulds | 6 |
| 4.4 Cleaning of the piston and of the rising main | 6 |
| 4.5 Filling the moulds | 6 |
| 5 Measurement of the development of strength | 7 |
| 6 Calculation | 7 |
| 7 Test report | 7 |
| Annex A (informative) Bibliography | 7 |

1 Scope

This European Standard specifies the method for determining the development of tensile strength during cure of resins, such as epoxy resins.

2 Test principle

The development of tensile strength is determined by measuring the tensile strength of the resin system at various ages of cure, and by interpolation arriving at the time to achieve the strength of 3 N/mm².

This test deals with two component resins for injection.

3 General requirements for testing

3.1 Laboratory

- the laboratory in which these tests will be done shall be equipped with a testing machine (see annex A). A self aligning tensile strength test shall be carried out with a deformation velocity of 0,1 mm/min;
- a conditioning room for resins before testing;
- the testing machine shall be equipped with a temperature controlled cabinet which allows the maintenance of a constant temperature from $(5 \pm 1) ^\circ\text{C}$ to $(21 \pm 2) ^\circ\text{C}$, or other temperatures, providing all parties concerned agree.

3.2 Apparatus

- a) Testing machine (see annex A), by means of a centric tensile test at a deformation rate of 0,1 mm/min;
- b) stopwatch.

The development of strength is measured with the apparatus shown in Figure 1.

The apparatus consists of at least six moulds: cavities and pistons as dimensioned in Figure 1.

The upper fixing device shall be constructed with universal joints in the tensile rod. All parts shall be made of steel.

The mould has a depth of

$2 \begin{smallmatrix} +0,05 \\ 0 \end{smallmatrix}$ mm and a diameter of

$25 \begin{smallmatrix} +0,05 \\ 0 \end{smallmatrix}$ mm (see Figure 2).

The piston shall have a diameter of

$25 \begin{smallmatrix} 0 \\ -0,05 \end{smallmatrix}$ mm (see Figure 3).

3.3 Materials

Two component epoxy resins or other, as specified.

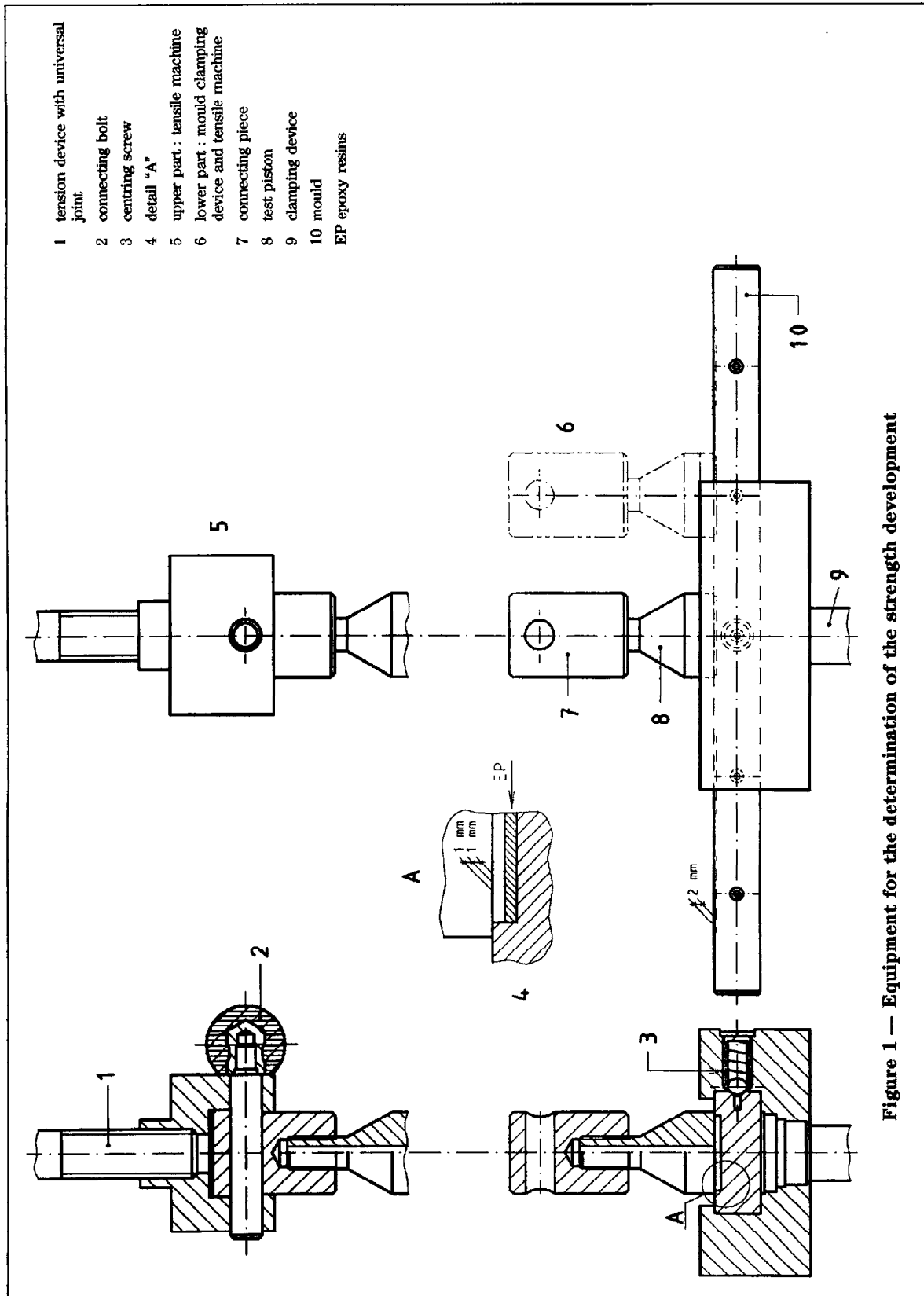

Figure 1 — Equipment for the determination of the strength development

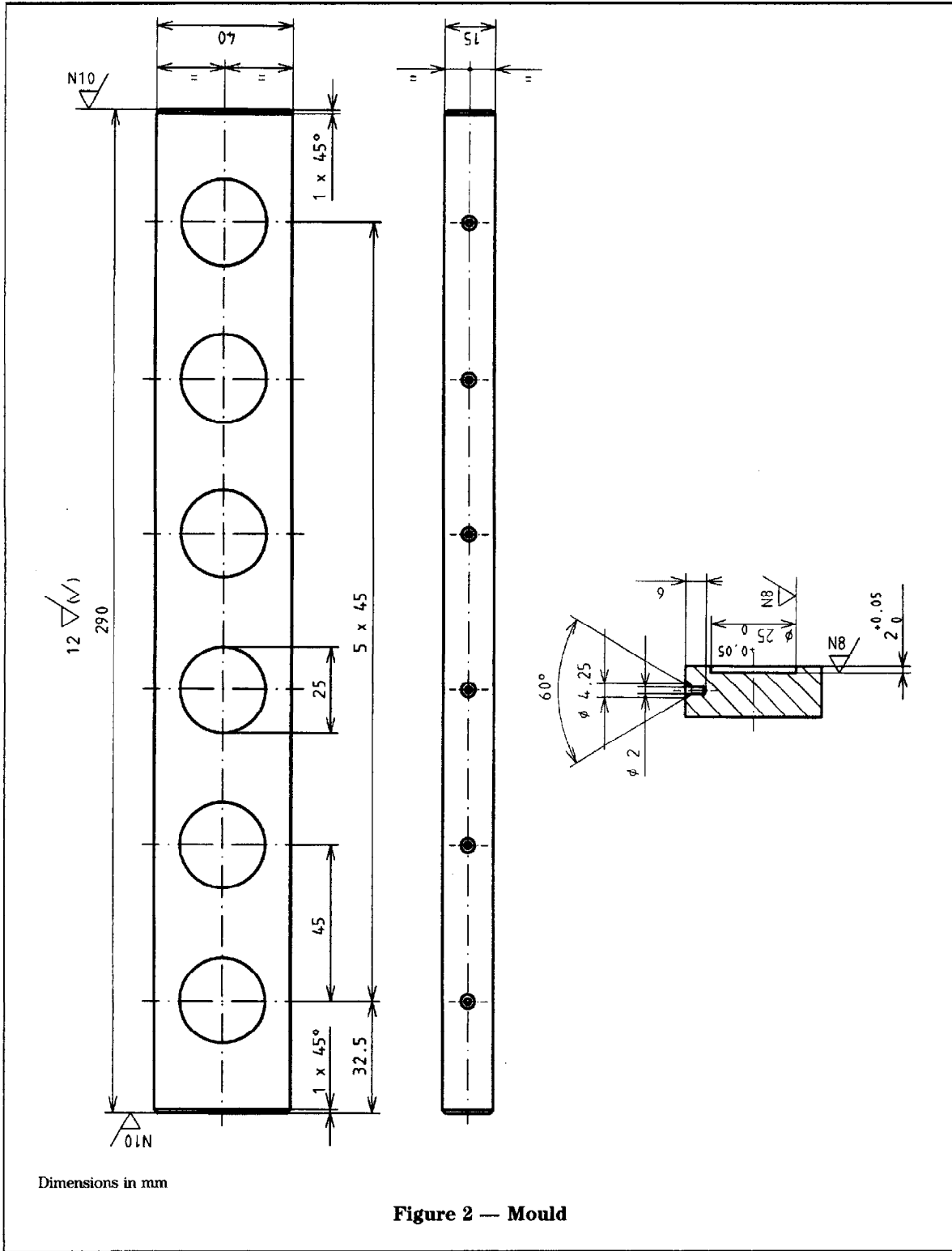
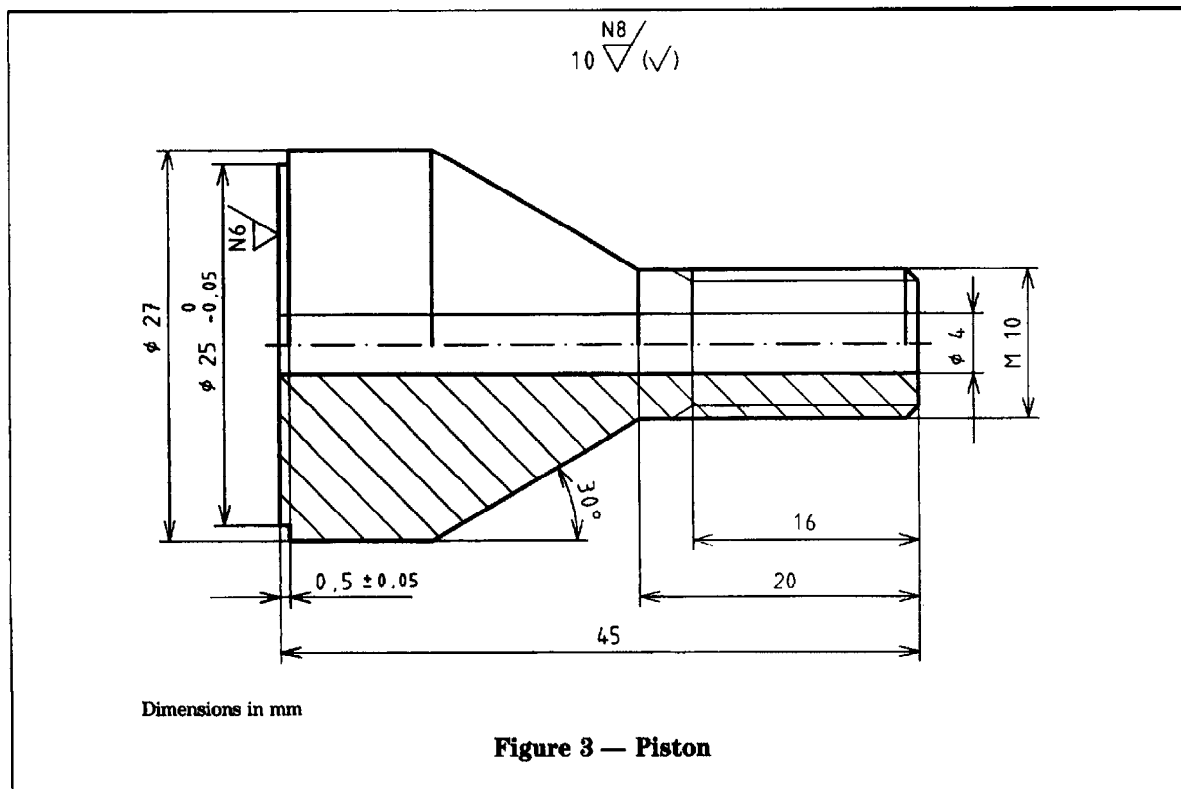

Figure 2 — Mold



4 Test procedure for the determination of the development of strength

4.1 Preparation of the resin

The two components shall be prepared in accordance with the technical data sheet of the manufacturer of the product.

The two component resins and the test apparatus shall be maintained at the selected test temperature for a minimum of 24 h before mixing the resins. The temperatures designated for the tests are $(5 \pm 1)^\circ\text{C}$, $(15 \pm 2)^\circ\text{C}$, $(21 \pm 2)^\circ\text{C}$, but other suitable temperatures may be selected providing all parties concerned agree.

4.2 Mixing

The base and hardener components shall be carefully mixed together, by means of a slowly rotating electric stirrer and paddle, in accordance with the manufacturer's recommendations. To complete the mixing process, the resin shall be poured from one can to another and mixed again for 30 s. Start the stopwatch at the end of the mixing.

4.3 Preparation of the moulds

The cavity of the mould and the faces of the piston shall be abraded to provide a mechanical key. To prevent adhesion of excess of resin, the upper face of the mould plate shall be lightly smeared with a release agent.

4.4 Cleaning of the piston and of the rising main

Remaining resin at the piston shall be removed by solvent (e.g. 70 % dichloromethane, 20 % formic acid, 10% trichlorethylene) or other suitable solvent.

4.5 Filling the moulds

Immediately after mixing, the resin shall be poured into a 2 mm deep, 25 mm diameter recess to fill up about 1 mm.

The piston shall then be carefully lowered into position until its shoulder rests upon the upper face of the mould plate displacing excess resin through the central hole.

Storing and testing of the prepared specimen shall be done at the same temperature as described in 4.1.

5 Measurement of the development of strength

The time of cure shall be measured from the completion of the mixing.

For the validity of the test, it is necessary to get at least six correct results at each temperature.

At various ages of cure, the resin mould and piston shall be fixed to the tensile machine and the tensile strength measured, a tensile load is applied until failure occurs. The velocity of the deformation is 0,1 mm/min.

The maximum value of the tensile force shall be recorded. The tensile strength shall be calculated in relation to the surface area of the piston.

The time interval between tests shall be adjusted to give a spread of at least six results within the range 0 N/mm² to > 5,0 N/mm² (one below 1 N/mm² and one above 5 N/mm²).

6 Calculation

The results shall be plotted as a graph tensile strength against cure time.

The time to reach 3 N/mm² is determined from the graph by interpolation and given to an accuracy of 1 min, this being done for each temperature.

7 Test report

The report shall contain the following informations:

- the identity and source of the product;
- reference to this European Standard;
- the date and place of sampling and testing;
- the temperature of testing;
- the mixing time;
- a plot of tensile strength against cure time for each test temperature;
- the rate of development of strength of 3 N/mm²;
- the diameter and depth of each mould;
- the interpolated cure time in minutes to reach a tensile strength of 3 N/mm².

Annex A (informative)

Bibliography

- [1] *Requirements for machines for tension and compression testing of materials*
(International Organization of Metrology, R 65, 1985)

BSI — British Standards Institution

BSI is the independent national body responsible for preparing British Standards. It presents the UK view on standards in Europe and at the international level. It is incorporated by Royal Charter.

Revisions

British Standards are updated by amendment or revision. Users of British Standards should make sure that they possess the latest amendments or editions.

It is the constant aim of BSI to improve the quality of our products and services. We would be grateful if anyone finding an inaccuracy or ambiguity while using this British Standard would inform the Secretary of the technical committee responsible, the identity of which can be found on the inside front cover. Tel: 0181 996 9000. Fax: 0181 996 7400.

BSI offers members an individual updating service called PLUS which ensures that subscribers automatically receive the latest editions of standards.

Buying standards

Orders for all BSI, international and foreign standards publications should be addressed to Customer Services. Tel: 0181 996 7000. Fax: 0181 996 7001.

In response to orders for international standards, it is BSI policy to supply the BSI implementation of those that have been published as British Standards, unless otherwise requested.

Information on standards

BSI provides a wide range of information on national, European and international standards through its Library and its Technical Help to Exporters Service. Various BSI electronic information services are also available which give details on all its products and services. Contact the Information Centre. Tel: 0181 996 7111. Fax: 0181 996 7048.

Subscribing members of BSI are kept up to date with standards developments and receive substantial discounts on the purchase price of standards. For details of these and other benefits contact Membership Administration. Tel: 0181 996 7002. Fax: 0181 996 7001.

Copyright

Copyright subsists in all BSI publications. BSI also holds the copyright, in the UK, of the publications of the international standardization bodies. Except as permitted under the Copyright, Designs and Patents Act 1988 no extract may be reproduced, stored in a retrieval system or transmitted in any form or by any means – electronic, photocopying, recording or otherwise – without prior written permission from BSI.

This does not preclude the free use, in the course of implementing the standard, of necessary details such as symbols, and size, type or grade designations. If these details are to be used for any other purpose than implementation then the prior written permission of BSI must be obtained.

If permission is granted, the terms may include royalty payments or a licensing agreement. Details and advice can be obtained from the Copyright Manager. Tel: 0181 996 7070.