

# Testing hardened concrete —

## Part 4: Compressive strength — Specification for testing machines

The European Standard EN 12390-4:2000 has the status of a  
British Standard

ICS 91.100.30

**NO COPYING WITHOUT BSI PERMISSION EXCEPT AS PERMITTED BY COPYRIGHT LAW**

---



## National foreword

This British Standard is the official English language version of EN 12390-4:2000. It will supersede BS 1881-115:1986, which will be withdrawn in 2003 when the full package of the related concrete package is available.

The UK participation in its preparation was entrusted by Technical Committee B/517, Concrete, to Subcommittee B/517/1, Production and testing, which has the responsibility to:

- aid enquirers to understand the text;
- present to the responsible European committee any enquiries on the interpretation, or proposals for change, and keep the UK interests informed;
- monitor related international and European developments and promulgate them in the UK.

A list of organizations represented on this subcommittee can be obtained on request to its secretary.

### Cross-references

The British Standards which implement international or European publications referred to in this document may be found in the BSI Standards Catalogue under the section entitled "International Standards Correspondence Index", or by using the "Find" facility of the BSI Standards Electronic Catalogue.

A British Standard does not purport to include all the necessary provisions of a contract. Users of British Standards are responsible for their correct application.

**Compliance with a British Standard does not of itself confer immunity from legal obligations.**

### Summary of pages

This document comprises a front cover, an inside front cover, the EN title page, pages 2 to 15 and a back cover.

The BSI copyright notice displayed in this document indicates when the document was last issued.

This British Standard, having been prepared under the direction of the Sector Committee for Building and Civil Engineering, was published under the authority of the Standards Committee and comes into effect on 15 July 2000

© BSI 07-2000

ISBN 0 580 35400 8

### Amendments issued since publication

Amd. No.	Date	Comments



**Contents**

	<b>Page</b>
<b>Foreword</b> .....	2
<b>1 Scope</b> .....	3
<b>2 References</b> .....	3
<b>3 Definitions</b> .....	4
<b>4 Construction of machines</b> .....	4
<b>5 Machine calibration</b> .....	8
<b>6 Details to be provided by the supplier/manufacturer</b> .....	8
<b>Annex A (normative) Strain gauged column and proving procedure for compression testing machines</b> .....	9
<b>Annex B (normative) Force calibration procedures</b> .....	12

**Foreword**

This European Standard has been prepared by Technical Committee CEN/TC 104, Concrete (performance, production, placing and compliance criteria), the Secretariat of which is held by DIN.

This European Standard shall be given the status of a national standard, either by publication of an identical text or by endorsement, at the latest by October 2000, and conflicting national standards shall be withdrawn at the latest by December 2003.

According to the CEN/CENELEC Internal Regulations, the national standards organizations of the following countries are bound to implement this European Standard: Austria, Belgium, Czech Republic, Denmark, Finland, France, Germany, Greece, Iceland, Ireland, Italy, Luxembourg, Netherlands, Norway, Portugal, Spain, Sweden, Switzerland and the United Kingdom.

This standard is one of a series concerned with testing concrete.

During the 1980s a number of countries found it necessary to introduce standards to specify more precisely the performance of compression machines for testing concrete specimens. This standard has been written to continue this movement and to overcome the present lack of a European Standard.

A draft for this standard was published in 1996 for CEN enquiry as prEN 12390. It was one of a series of individually numbered test methods for fresh or hardened concrete. For convenience it has now been decided to combine these separate draft standards into three new standards with separate parts for each method, as follows:

- Testing fresh concrete (EN 12350);
- Testing hardened concrete (EN 12390);
- Testing concrete in structures (EN 12504).

This series, EN 12390, includes the following parts where the brackets give the numbers under which the particular test methods were published for CEN enquiry:

- Part 1: Shape, dimensions and other requirements of specimens and moulds (former prEN 12356:1996);
- Part 2: Making and curing specimens for strength tests (former prEN 12379:1996);
- Part 3: Compressive strength of test specimens (former prEN 12394:1996);
- Part 4: Compressive strength – Specification for testing machines (former prEN 12390:1996);
- Part 5: Flexural strength of test specimens (former prEN 12359:1996);
- Part 6: Tensile splitting strength of test specimens (former prEN 12362:1996);
- Part 7: Density of hardened concrete (former prEN 12363:1996);
- Part 8: Depth of penetration of water under pressure (former prEN 12364:1996).

Three classes of testing machines are currently recognized, corresponding to scale accuracies of 1 %, 2 % and 3 %. It is evident that these accuracy classes have a direct impact upon the accuracy of the test result and it is a matter for each country to decide whether to limit the range of machine classes to, for example, 1 % and 2 %.

The amendment to this standard for the purpose of Commission Decision 2004/18/EC is intended to be effective from 1 January 2006.

### 3 Definitions

For the purposes of this standard the following definitions apply.

#### 3.1 auxiliary platen

separate platen used to protect the machine platens, usually of a size equal to the designated size of the specimen being tested

#### 3.2 contact area

the part of the platen that comes into contact with the specimen

#### 3.3 indicated force

the force indicated on the machine scale(s) or display

#### 3.4 indication range

the total force range, from zero to maximum, displayed on the machine

#### 3.5 machine platens

lower platen and upper platen with spherical seating both centred on the central vertical axis of the machine

#### 3.6 measuring range

that part of an indication range over which the machine conforms with the accuracy values specified in this standard

#### 3.7 relative accuracy error of

##### 3.7.1 true force

the difference between the average indicated force and the true force expressed as a percentage of the true force

##### 3.7.2 indicated force

the difference between the average true force and the indicated force expressed as a percentage of the indicated force

#### 3.8 relative repeatability error of

##### 3.8.1 true force

the greatest difference between the indicated forces corresponding to repeated applications of a true force expressed as a percentage of the true force

##### 3.8.2 indicated force

the greatest difference between the true forces corresponding to repeated applications of an indicated force expressed as a percentage of the indicated force

#### 3.9 resolution of force

the smallest increment of force that can be assessed, estimated, or read on any force indication range (see annex B)

#### 3.10 spacing block

metal block used to adjust the space available to test specimens

#### 3.11 true force

the force indicated on a calibrated force proving device

### 4 Construction of machines

#### 4.1 Machine platens, auxiliary platens and spacing blocks

NOTE 1: The use of auxiliary platens is optional.

4.1.1 Machine and auxiliary platens shall be made of a material which shall not deform irreversibly when the machine is used.

**4.1.2** Machine and auxiliary platens shall have a hardness value of at least 550 HV 30 (HRC 53) when tested in accordance with ISO 6507-1.

**4.1.3** The flatness tolerance for machine platens and auxiliary platens shall be 0,03 mm for the area in contact with the specimen.

**NOTE 2:** For the purpose of this European Standard, flatness can be assessed by the measurement of straightness in four positions (see annex B of prEN 12390-1:1999).

**4.1.4** The roughness value ( $R_a$ ) for the surface texture of machine and auxiliary platens shall be in the range 0,4  $\mu\text{m}$  to 3,2  $\mu\text{m}$ , when assessed in accordance with ISO/R468, for the area in contact with the specimens.

**4.1.5** The area of machine platens in contact with the specimen shall be at least as great as the area of the specimen being tested.

**4.1.6** The distance between either pair of opposite edges of a square auxiliary platen, or the diameter of a circular auxiliary platen, shall be not less than the designated size of the specimen.

**4.1.7** The two contact faces of an auxiliary platen shall be parallel to a tolerance of 0,05 mm.

**4.1.8** Auxiliary platens shall be at least 23 mm thick.

**4.1.9** If there is a requirement to reduce the distance between the machine platens, up to four spacing blocks may be used.

**4.1.10** A spacing block may be either circular or square in section and shall be adequately supported from below.

**NOTE 3:** A minimum diameter or length of side of 200 mm is recommended for spacing blocks.

**4.1.11** Spacing blocks shall comply with the flatness and parallelism tolerances required for auxiliary platens (see clauses 4.1.3 and 4.1.7).

**4.1.12** Spacing blocks shall not be placed in contact with the specimen.

**4.1.13** Spacing blocks shall be positively located, centrally on the vertical machine axis.

## **4.2 Force measurement**

### **4.2.1 Force indicator**

The machine shall be provided with:

- dials or digital displays which allow the force to be read to the required accuracy (see B.1.2);
- a system which allows the maximum force sustained to be read after completion of the test, until reset;
- displays readable from the operating position.

The lowest verifiable value (see B.1.4) of each measuring range shall be less than or equal to 20 % of the maximum value of the range. If the machine is equipped with several indication ranges, the above requirement shall apply to each range.

The machine force indication system shall not be affected by explosive failure of the specimen.

### **4.2.2 Force indicator calibration**

Force indicators shall be verified and shall conform to the requirements of Table 1 for the particular class of testing machine.

**Table 1: Force scale tolerances**

Machine class	Relative accuracy error % <sup>2)</sup>	Relative repeatability error % <sup>2)</sup>	Relative zero error (% of scale maximum) % <sup>2)</sup>	Machine resolution <sup>1)</sup> % <sup>2)</sup>
1	±1,0	1,0	±0,2	0,5
2	±2,0	2,0	±0,4	1,0
3	±3,0	3,0	±0,6	1,5

<sup>1)</sup> See definition in 5.3 of EN 10002-2:1998.  
<sup>2)</sup> The tabulated percentages are the maximum permitted for the related machine classes.

**4.2.3 Force indicator repeatability**

The requirements of Table 1, appropriate to a machine's class, shall apply to each measuring range.

**4.2.4 Accuracy of force indication**

The accuracy of force indication shall be maintained under any or all of the following circumstances:

- mains voltage fluctuations of -14 % to +10 %;
- at a temperature of (20 ± 10) °C;
- at a relative humidity of up to 80 %.

**NOTE:** Where electrical or other interference exists this can affect the accuracy of force indication and special provisions to overcome this interference can be necessary.

**4.2.5 Deviation in linearity**

If a DC output, proportionate to the indicated force is provided, the linearity deviation of the output voltage - expressed as a percentage of the maximum output voltage - shall not exceed the value shown in Table 2.

**Table 2: Deviation in the linearity of the output voltage**

Maximum permissible deviation in linearity in relation to the maximum output voltage	
Machine class	%
1	±0,1
2	±0,2
3	±0,3

**4.3 Force control**

**4.3.1** The compression testing machine shall be provided with a control system. The control system shall enable the machine to be verified and to allow force to be applied smoothly and without shock. It shall also allow the force to be applied at prescribed constant rates.

**4.3.2** The control system may be operated either by manual or automatic means.

**4.3.3** If the machine is not equipped with automatic application of force, a pacer shall be fitted to enable the operator to maintain the specified rate. The pacer shall indicate a rate within ±5 % of the specified rate.



#### 4.4 Force transfer

4.4.1 Unless national provisions state otherwise, clauses 4.4.5 to 4.4.8 shall apply only to new machines delivered after this standard is implemented.

4.4.2 The upper platen shall incorporate a ball-seating. The upper platen and the ball-seating may be constructed separately or in one piece.

4.4.3 At the design stage, the manufacturer shall ensure that the centre of rotation of the ball-seating shall coincide with the centre of the contact area of the machine platen and permit a rotation of at least three degrees.

4.4.4 At the start of a test, the upper platen shall align itself with the surface of the specimen, or an auxiliary platen, when the initial contact is made, before locking into position for the remainder of the test.

4.4.5 The design shall ensure that the requirements of Table 3 shall be met.

4.4.6 The force transfer shall be evaluated by means of a strain-gauged column as described in annex A, or by an equivalent device.

4.4.7 The machine shall be designed to enable devices as set out in annexes A and B, or similar, to be used for verifying:

- accuracy of force indication;
- self alignment of the upper machine plate;
- alignment of component parts of the machine;
- restraint of movement of the upper plate.

4.4.8 When tested in accordance with annex A, or equivalent method, the machine shall conform to Table 3.

**Table 3: Maximum permissible values for the mean strain ratio, the greatest difference in the strain ratio, and the strain ratio per mm of displacement**

Force kN	Self alignment of upper machine plate	Alignment of machine components	Restraint on movement of upper plate
	Maximum permissible difference in the strain ratio	Maximum permissible mean strain ratio	Maximum permissible strain ratio per mm of displacement
200	0,10	±0,10	0,06
2 000	N/A	N/A	0,04

NOTE: The highest force (used only in the examination of restraint of movement of the upper platen) shall be the maximum capacity of the machine or 2 000 kN whichever is the lesser.

#### 4.5 Specimen location

4.5.1 To ensure correct positioning of the specimen in relation to the loading axis, the lower machine platen shall be provided with centring lines, locating cams or other fixtures for centring specimens.

4.5.2 If positive physical location is used for positioning specimens or auxiliary platens, then any locating device shall not restrict the deformation of the specimen during the test.

4.5.3 Centring lines, if provided, shall be no more than 0,5 mm wide and no more than 1,0 mm deep.

## 5 Machine calibration

### 5.1 Characteristics to be assessed

The examination for correct operation of a testing machine shall consist of calibrating:

- the accuracy of the force indication;
- the force transfer (stability) (only for new machines, unless national provision requires otherwise);
- flatness of the platens;
- control of rate of application of force.

### 5.2 Frequency of calibration

Calibrate according to 5.1 when the machine is first installed.

Re-calibration shall be undertaken at a rate stipulated by an accredited quality system or annually and after:

- relocating the machine; or
- repair or replacement of any part likely to affect the characteristics verified in 5.1.

## 6 Details to be provided by the supplier/manufacture

### 6.1 Specification

The supplier/manufacture shall indicate at least the following details in the specification of the test machine:

- a) testing machine class according to this standard;
- b) indication range (or ranges);
- c) measuring range (or ranges);
- d) description of the measuring indicator;
- e) dimensions of the platens;
- f) dimensions of the auxiliary platens (if appropriate);
- g) minimum and maximum height between the platens, and the maximum lateral access;
- h) maximum usable ram stroke;
- i) description of the maximum force indicator (e.g. slip pointer, peak value detector).

### 6.2 Installation and connection

The supplier/manufacture shall provide at least the following installation and connection details:

- a) dimensions of the machine;
- b) weight of the machine;
- c) drawing of the foundations, if appropriate;
- d) details of electrical requirements;
- e) detailed operating instructions.

### 6.3 Maintenance

The supplier/manufacture shall provide at least the following maintenance details:

- a) maintenance schedule, including the requirements for the ball-seating;
- b) details of the oil to be used in the hydraulic sections.

## ANNEX A (normative)

### STRAIN GAUGED COLUMN AND PROVING PROCEDURE FOR COMPRESSION TESTING MACHINES

NOTE 1: These procedures should be carried out by experts. They are included to give a standard form of proving device and procedure for those laboratories qualified to conduct the test.

NOTE 2: Where it can be demonstrated that other devices and methods of verification will provide comparable verification of the requirements, the use of these alternatives is permitted.

#### A.1 The strain gauged column

The strain gauged column shall be a cylinder of nickel-chrome steel and tempered to a hardness value of at least 370HV 30. It shall be  $(100 \pm 1)$  mm in diameter and  $(200 \pm 1)$  mm high. The flatness tolerance for the ends shall be 0,03 mm but the surfaces shall not be convex. The parallelism tolerance shall be 0,06 mm. The squareness tolerance of the cylinder, with respect to one end as datum face, shall be 0,03 mm. The roundness tolerance of the ends of the cylinder shall be 0,02 mm, and the whole cylinder shall be within a cylindricity tolerance of 0,04 mm. Centre holes of maximum size 15 mm diameter by 15 mm deep are permitted in the ends of the cylinder.

The column shall be gauged using matched temperature-compensated electrical resistance strain gauges. Four complete bridges, each centred at one of the ends of a pair of orthogonal diameters half-way up the cylinder, shall be used. Each bridge shall consist of two elements measuring axial strain and two measuring circumferential strain as shown in Figure A.1. Each bridge shall be electrically and thermally balanced.

The column shall be supported in a carrying box by circumferential shoulders near the ends of the cylinder. The edge of each shoulder nearest the centre of the cylinder shall be not further than 15 mm from the nearest end of the cylinder. Vertical lines shall be inscribed on the cylinder walls so that they are visible outside the carrying case to indicate the position of the centre lines of the bridges. These lines shall not extend further than 20 mm from the lower end of the cylinder.

The column shall be used with a switch and balance unit which enables the outputs of each of the four bridges to be balanced in the unforced condition and the bridge outputs to be selected thereafter by operation of a switch.

NOTE: Alternatively, simultaneous display of the four bridge outputs can be used if means are provided to enable the sensitivity of the four channels to be checked and, if necessary, equalized immediately prior to taking a series of readings.

The strain gauged column shall be used in conjunction with dedicated strain measuring equipment.

The maximum limit of error for strain measuring equipment shall be  $\pm 0,1$  % or 5 micro strain, whichever is greater.

The strain gauged column with its dedicated strain measuring equipment shall be calibrated to national standards at least every two years.

#### A.2 Procedure for verifying the self-alignment of the upper machine platen and the component parts of the machine

Locate the device centrally on the lower machine platen or a 150 mm square auxiliary platen as shown in Figure A.2. Designate the mid-points of the edges of the platen, or auxiliary platen, as A, B, C and D, and the four bridge positions on the device 1, 2, 3 and 4.

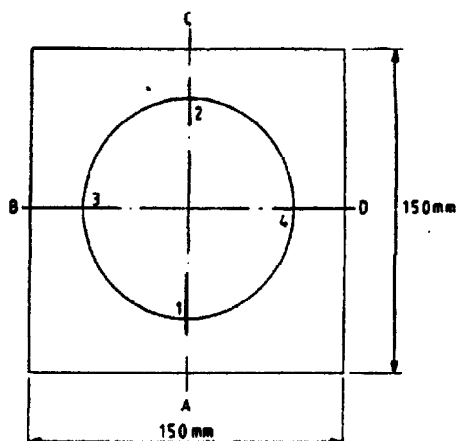
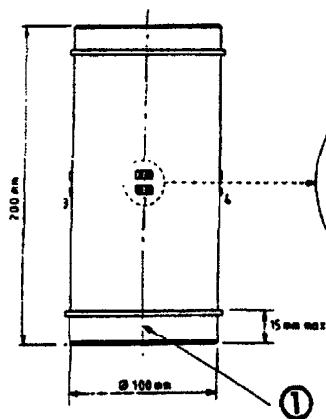

1) Lines indicating centre of bridges

Figure A.1 - Gauging of device

Figure A.2 - Positioning

Measure the distances from the centre of each top edge of the positioning platen to the nearest point on the bottom edge of the device and adjust the position of the device until the differences between pairs of measurements from opposite edges of the platen to the device do not exceed 0,10 mm.

NOTE: This can be conveniently achieved by fitting a stop to the edge of the platen and providing accurately machined spacers to centralize the device, or by the use of a jig unique to a given device.

Operate the machine to bring the top of the device no closer than 5 mm to the upper machine platen and tilt the upper machine platen down towards A about axis BD either to its fullest extent or until it touches the device. Gently release the upper machine platen and operate the machine so that the upper machine platen aligns with the device. Increase smoothly the indicated force onto the device up to a nominal value of at least 200 kN. Hold the force constant and read the outputs of the four bridges. If the force exceeds 200 kN but does not exceed 220 kN before it can be held constant, do not reduce it before taking the readings. If the force exceeds 220 kN restart the test.

Use the mean  $e_m$  of the four bridge outputs  $e_1$ ,  $e_2$ ,  $e_3$  and  $e_4$  to calculate the strain ratio  $(e_n - e_m)/e_m$  for each bridge, where  $e_n$  is the strain at the bridge position under consideration.

Repeat the test; firstly with the upper machine platen tilted down towards C about an axis BD, secondly with the upper machine platen tilted down towards B about an axis AC, and thirdly with the upper machine platen tilted down towards D about an axis AC.

If the device is correctly machined and gauged, the sensitivity of the four bridges will be equal. However, if this is in doubt, repeat the readings, first with bridge 1 adjacent to B, then with bridge 1 adjacent to C and finally with bridge 1 adjacent to D (see Figure A.2).

The readings so obtained, together with those obtained with bridge 1 opposite A, shall be meaned to eliminate differences in bridge sensitivity on the device. This shall be done for the readings on all four bridges.

### A.3. Self-alignment of the upper machine platen

Obtain the strain ratios at 200 kN for the four different directions of initial platen tilt and compare them with the requirements set out in Table 3.

#### A.4 Alignment of the component parts of the machine

If the self-alignment is correct (see A.3), calculate the mean strain ratios for each of the four bridges and compare them with the requirements set out in Table 3.

#### A.5 Procedure for verifying restraint on movement of the upper platen

If the self-alignment and alignment are correct (see A.3 and A.4) displace the device by  $(6 \pm 0,05)$  mm from the central position along AC towards A. Without further adjustment of the upper machine platen, operate the machine to bring the device into contact with it and apply the force smoothly. Record the outputs of the four bridges at nominal forces of 200 kN and 2 000 kN. If the machine capacity is less than 2 000 kN, take readings at 200 kN and at maximum capacity. Take care to ensure that the output of each of the four bridges is read while the force is held constant. If either nominal force is exceeded, but by 10 % or less, before it can be held constant do not reduce it before taking the readings. If either nominal force is exceeded by more than 10 %, restart the test.

Repeat these readings with the device displaced  $(6 \pm 0,05)$  mm from the central position, firstly along AC towards C, secondly along BD towards B and thirdly along BD towards D. Let  $r$  represent a strain ratio. Use subscripts 1, 2, 3 and 4 to denote the positions of the bridges on the strain cylinder (as in Figure 2), and use subscripts a, b, c and d to denote displacement of the cylinder towards A, B, C and D, so that, for example,  $r_{1a}$  denotes the strain ratio for bridge number 1 when the cylinder is displaced 6 mm towards A.

For each force, calculate the change in strain ratio per millimetre offset for displacement along AC as:

$$\frac{(r_{1c} - r_{2c}) - (r_{1a} - r_{2a})}{24} \quad (\text{A.1})$$

and calculate the change in strain ratio per millimetre offset for displacement along BD as:

$$\frac{(r_{3d} - r_{4d}) - (r_{3b} - r_{4b})}{24} \quad (\text{A.2})$$

#### A.6 Safety requirements

When using the device, particularly when it is at an eccentric setting, care shall be taken to ensure that the indicated force does not exceed the specified value of the device.

The device shall be clearly marked indicating the '*maximum permitted force when applied centrally*'.

NOTE: If the device is overloaded in an eccentric position, there is a danger that the horizontal motive forces resulting from a one-side compression of the device can exceed the retaining friction forces between the compression surfaces of the testing machine and those of the device, which would cause the device to be projected violently from the testing zone.

**ANNEX B (normative)****FORCE CALIBRATION PROCEDURES****B.1. General**

**B.1.1** The forces applied by uniaxial materials testing machines shall be calibrated according to the procedures described to allow a categorization for repeatability and error of force. To ensure that the class is consistent with the resolution of the force indication, a lower limit of calibration shall be determined.

**B.1.2 Resolution (see Table 1)****B.1.2.1 Analogue scale**

The width of the graduation marks defining the smallest scale interval on the scale shall be uniform and approximately equal to the width of the pointer. If the force indication is made by means of a chart recorder, the width of the lines defining the smallest scale interval on the chart should be uniform and approximately equal to the width of the trace.

NOTE: The width of a graduation mark should not exceed the resolution allowable for a considered scale.

A scale interval shall be subdivided by estimation to determine the resolution ( $r$ ) as follows:

- a) when the scale interval is at least 2,5 mm wide, the resolution is one-tenth of a scale interval;
- b) when the scale interval is at least 1,25 mm wide and less than 2,5 mm wide the resolution is one-fifth of a scale interval;
- c) when the scale interval is less than 1,25 mm wide, the resolution is one-half of a scale interval.

The resolution shall be expressed in units of force.

If the force indication is by means of a chart record, the nominal width and the graduation interval of the chart paper used shall be recorded. The grading of the machine is applicable only when chart paper of the same type is used. If there is no facility for generating an electrical calibration input to a chart recorder so that small changes in the width of the chart paper may be accommodated, then the overall width of the chart used during the calibration shall be measured to an accuracy equivalent to the resolution and shall be recorded. The width of chart paper subsequently used shall be within  $\pm 2r$  of this width.

**B.1.2.2 Digital scale**

The resolution shall be determined when there is no force applied by the materials testing machine and shall be equal to one-half of the range of fluctuation on the digital read-out but shall be not less than one increment of count.

The resolution shall be expressed in units of force.

**B.1.3 Calibration**

Calibration shall be carried out for each force-measuring system for which a class is sought.

**B.1.4 Lower limit of calibration**

Calibration shall not be performed below the lower limit  $F_v$  on any force-measuring system determined as follows:

$$F_v = a \times r$$

where:

*a* has the following values:      200 for class 1 machine;  
   100 for class 2 machine;  
   66,6 for class 3 machine.

*r* is the resolution determined in accordance with B.1.2.

NOTE: Calibration should not be started unless the testing machine is in good working order.

## **B.2. Calibration equipment**

The force calibration equipment shall conform to EN 10002-3 when calibrated in the increasing load mode. The requirement in EN 10002-3 for calibration in decreasing load mode is not applicable to force verification equipment used for the verification of compression testing machines specified in this standard. The class of the force calibration equipment shall be equal or superior to the proposed class of the machine to be verified.

The calibration equipment shall be calibrated to national standards at least every two years.

## **B.3. Preliminary procedure**

### **B.3.1 Alignment**

The calibration equipment shall be mounted in the machine so that the forces are applied along the loading axis of the machine.

### **B.3.2 Temperature compensation**

Sufficient time shall be allowed for the calibration equipment to attain a stable temperature. The temperature at the beginning and end of the application of each series of forces shall be recorded. Where necessary, temperature corrections shall be applied to the deflections of proving devices.

### **B.3.3 Machine conditioning**

The materials testing machine and calibration equipment shall be exercised three times between zero force and the maximum force to be measured. The machine's force indicator shall then be reset to zero.

A spherical seated platen satisfying the requirements of annex A shall be deemed to provide the necessary alignment of machine platens and proving devices; no additional, auxiliary alignment provision should be required.

## **B.4. Calibration procedure**

### **B.4.1 Method**

One of the following calibration methods shall be used.

- a) True force  
The machine shall be operated to balance a given true force as determined by the calibration equipment. The machine's indicated force shall then be recorded.
- b) Indicated force  
The machine shall be operated to apply a given indicated force and the true force measured by the calibration equipment recorded.

## **B.4.2 Selection of test forces**

### **B.4.2.1 General**

The total number of forces required to calibrate a materials testing machine depends on the number of ranges over which the machine is constructed to operate; the appropriate number of forces given in B.4.2.2 to B.4.2.4 shall be used.

### **B.4.2.2 Single-range materials testing machines**

A series of at least five approximately equi-spaced forces, upwards from 20 % of the scale maximum or the lower limit of calibration, whichever is greater, shall be used.

When the lower limit of calibration is below 20 % of the scale maximum, additional forces may be applied below 20 % of the scale maximum down to and including the lower limit of calibration. Working downwards from 20 % of the scale maximum, consecutive forces shall not differ by more than 6 % of the scale maximum.

### **B.4.2.3 Multi-range materials testing machines**

Each range shall be verified as described in B.4.2.2.

### **B.4.2.4 Materials testing machines with auto ranging digital indicators**

A series of at least five approximately equi-spaced forces, upwards from 20 % of the maximum reading of the digital indicator shall be applied. At least one additional force for each 6 % of the maximum reading, working downwards from the 20 % point to the lower limit of calibration (see B.4.2.3), shall be applied. At least two forces shall be verified on each part of the range where the increment of count does not change.

## **B.4.3 Application of test forces**

### **B.4.3.1 Procedure**

For each range, the series of forces in ascending order shall be applied and each series repeated to give three series of such forces. The force shall be completely removed after each series of applications. The zero reading shall be recorded not less than 30 s and not more than 2 min after removing the force.

The reading of the force indicator shall be zeroed after removing the force with the machine in the same mechanical condition, as it was in before applying the series of forces.

*If necessary, the force indicator shall be reset to zero at the commencement of each series of readings but a correction to readings already taken shall not be applied.*

**NOTE:** In some testing machines difficulty can be experienced in maintaining a steady force; in such circumstances measurements can then be made under conditions of slowly increasing force.

### **B.4.3.2 Maximum-reading facility**

When the force indicator is fitted with a maximum-reading facility which could introduce friction, e.g. a pointer-arresting mechanism or slave pointer, one of the series of forces with the facility in operation for each range of the machine shall be applied. The reading of the force indicator shall be zeroed with the facility disengaged.

### **B.4.3.3 Force indication by hydraulic pressure**

For machines employing a hydraulic ram and a method of force measurement derived from the hydraulic pressure, the series of forces shall be applied three times with the ram, where possible, in the normal working position.



## B.5 Calculation of results

At each nominal force, the repeatability and error from the results of all the applications of forces shall be calculated and expressed as a percentage of the nominal force.

The error of zero force for each series of forces shall be calculated and expressed as a percentage of the maximum force of the machine range.

The forces indicated by the materials testing machine shall not be corrected for the error of zero force.

## B.6 Classes

### B.6.1 Single range machines

At least five consecutive forces, from the maximum to be verified downwards, shall not exceed the values given in Table 1 for a specific class.

The class shall cease to apply below the last force that conforms to these requirements.

It is possible for a range to be given more than one class, but for each such category, all forces from the maximum downwards shall be considered. Thus a more exacting class shall not be introduced to cover some intermediate part of the range.

### B.6.2 Multi-range machines

Each range shall be a category according to B.6.1.

NOTE: The resolution and hence the lower limit of calibration can change when a new range is selected.

A machine with an auto-ranging digital indicator (i.e. an indicator where the increment of count of the indicated force changes automatically at given points between zero and the maximum reading) shall be categorized as a single-range machine as described in B.6.1. However, a class can only apply if, throughout the range category, the ratio of the indicated force to the increment of count at that force is not less than the following values:

66,6 for class 3 machine;  
100 for class 2 machine;  
200 for class 1 machine.

### B.6.3 Class certificate

When a materials testing machine has been categorized and calibrated in accordance with this annex, a certificate shall be issued stating the following:

- a) the identity and location of the materials testing machine and the date of calibration;
- b) the resolution, class, mode and range of forces on each force-measuring system calibrated;
- c) where appropriate, any force-measuring systems that were not calibrated;
- d) the method of calibration used and the identity, class and date of the certificate of grading of the calibration equipment used;
- e) whether or not a maximum-reading facility was used;
- f) the average temperature of the calibration equipment at the time of calibration;
- g) where appropriate, the type of chart paper used during the calibration and an accurate measurement of the width of the paper.

**BS EN**  
**12390-4:2000**

---

## **BSI — British Standards Institution**

BSI is the independent national body responsible for preparing British Standards. It presents the UK view on standards in Europe and at the international level. It is incorporated by Royal Charter.

### **Revisions**

British Standards are updated by amendment or revision. Users of British Standards should make sure that they possess the latest amendments or editions.

It is the constant aim of BSI to improve the quality of our products and services. We would be grateful if anyone finding an inaccuracy or ambiguity while using this British Standard would inform the Secretary of the technical committee responsible, the identity of which can be found on the inside front cover. Tel: 020 8996 9000. Fax: 020 8996 7400.

BSI offers members an individual updating service called PLUS which ensures that subscribers automatically receive the latest editions of standards.

### **Buying standards**

Orders for all BSI, international and foreign standards publications should be addressed to Customer Services. Tel: 020 8996 9001. Fax: 020 8996 7001.

In response to orders for international standards, it is BSI policy to supply the BSI implementation of those that have been published as British Standards, unless otherwise requested.

### **Information on standards**

BSI provides a wide range of information on national, European and international standards through its Library and its Technical Help to Exporters Service. Various BSI electronic information services are also available which give details on all its products and services. Contact the Information Centre. Tel: 020 8996 7111. Fax: 020 8996 7048.

Subscribing members of BSI are kept up to date with standards developments and receive substantial discounts on the purchase price of standards. For details of these and other benefits contact Membership Administration. Tel: 020 8996 7002. Fax: 020 8996 7001.

### **Copyright**

Copyright subsists in all BSI publications. BSI also holds the copyright, in the UK, of the publications of the international standardization bodies. Except as permitted under the Copyright, Designs and Patents Act 1988 no extract may be reproduced, stored in a retrieval system or transmitted in any form or by any means – electronic, photocopying, recording or otherwise – without prior written permission from BSI.

This does not preclude the free use, in the course of implementing the standard, of necessary details such as symbols, and size, type or grade designations. If these details are to be used for any other purpose than implementation then the prior written permission of BSI must be obtained.

If permission is granted, the terms may include royalty payments or a licensing agreement. Details and advice can be obtained from the Copyright Manager. Tel: 020 8996 7070.

---

BSI  
389 Chiswick High Road  
London  
W4 4AL