



جمهوری اسلامی ایران
Islamic Republic of Iran

سازمان استاندارد و تحقیقات صنعتی ایران

Institute of Standards and Industrial Research of Iran



استاندارد ملی ایران

۱۰۳۶۴-۲

چاپ اول

ISIRI

10364-2

1st.edition

ماشین آلات و تجهیزات ساختمان سازی -
مخلوط کن های بتون -
قسمت دوم : رویه آزمایش بازده مخلوط کنی

**Building construction machinery and
equipment -Concrete mixers -
Part 2:Procedure for examination of mixing
efficiency**

ICS: 91.220

بنام خدا

آشنایی با موسسه استاندارد و تحقیقات صنعتی ایران

موسسه استاندارد و تحقیقات صنعتی ایران به موجب بندیک ماده ۳ قانون اصلاح قوانین و مقررات موسسه استاندارد و تحقیقات صنعتی ایران، مصوب بهمن ماه ۱۳۷۱ تنها مرجع رسمی کشور است که وظیفه تعیین، تدوین و نشر استاندارد های ملی (رسمی) ایران را برعهده دارد.

تدوین استاندارد در حوزه های مختلف کمیسیون فنی مرکب از کارشناسان موسسه* صاحب نظران مراکز و موسسات علمی، پژوهشی، تولید و اقتصادی آگاه و مرتبط انجام می شود و کوششی همگام با مصالح ملی و با توجه به شرایط تولیدی، فناوری و تجاری است که از مشارکت آگاهانه و منصفانه صاحبان حق و نفع، شامل تولید کنندگان، مصرف کنندگان، صادر کنندگان و وارد کنندگان، مراکز علمی و تخصصی، نهادها، سازمان های دولتی و غیردولتی حاصل می شود. پیش نویس استاندارد های ملی برای نظر خواهی به مراجع ذی نفع و اعضاء کمیسیون های فنی مربوطه ارسال می شود. و پس از دریافت نظرها و پیشنهادهای در کمیته ملی مرتبط با آن رشته طرح در صورت تصویب به عنوان استاندارد ملی (رسمی) ایران چاپ و منتشر می شود.

پیش نویس استانداردهایی که موسسات و سازمانهای علاقه مند ذی صلاح نیز با رعایت ضوابط تعیین شده تهیه می کنند در کمیته ملی طرح و بررسی و در صورت تصویب، به عنوان استاندارد ملی (رسمی) چاپ و منتشر می شود. بدین ترتیب، استانداردهایی ملی تلقی می شود که براساس مفاد نوشته شده در استاندارد ملی ایران شماره ۵ تدوین و در کمیته ملی استاندارد مربوطه که موسسه استاندارد تشکیل می دهد به تصویب رسیده باشد.

موسسه استاندارد و تحقیقات صنعتی ایران از اعضای اصلی سازمان بین المللی استاندارد (ISO)^۱ کمیسیون بین المللی الکتروتکنیک (IEC)^۲ و سازمان بین المللی اندازه شناسی قانونی (OIML)^۳ است و به عنوان تنهاریابط^۴ کمیسیون کدکس غذایی (CAC)^۵ در کشور فعالیت می کند. در تدوین استاندارد های ملی ایران ضمن توجه به شرایط کلی و نیاز مندی های خاص کشور، از آخرین پیشرفت های علمی، فنی و صنعتی جهان و استاندارد های بین المللی بهره گیری می شود.

موسسه استاندارد و تحقیقات صنعتی ایران می تواند با رعایت موازین پیش بینی شده در قانون برای حمایت از مصرف کنندگان، حفظ سلامت و ایمنی فردی و عمومی، حصول اطمینان از کیفیت محصولات و ملاحظات زیست محیطی و اقتصادی اجرای بعضی از استانداردهای ملی ایران را برای محصولات تولیدی داخل کشور و / یا اقلام وارداتی با تصویب شورای عالی استاندارد، اجباری نماید. موسسه می تواند به منظور حفظ بازارهای بین المللی برای محصولات کشور، اجرای استاندارد کالاهای صادراتی و درجه بندی آن را اجباری نماید. همچنین برای اطمینان بخشیدن به استفاده کنندگان از خدمات سازمان ها و موسسات فعال، در زمینه آموزش، مشاوره، بازرسی، ممیزی و صدور گواهی سیستم های کیفیت و مدیریت زیست محیطی، آزمایشگاه ها و مراکز کالیبراسیون (واسنجی) و وسایل سنجش، موسسه استاندارد این گونه سازمان ها موسسات را براساس ضوابط نظام تایید صلاحیت ایران ارزیابی می کند و در صورت احراز شرایط لازم، گواهی تایید صلاحیت با آنها اعطاء و بر عملکرد آنها نظارت می کند. ترویج دستگاه بین المللی یکا های کالیبراسیون (واسنجی) و وسایل سنجش، تعیین عیار فلزات گرانبها و انجام تحقیقات کاربردی برای ارتقاء سطح استاندارد های ملی ایران از دیگر وظایف این موسسه است.

* موسسه استاندارد و تحقیقات صنعتی ایران

1- International Organization for standardization

2- International Electrotechnical commission

3 - International Organization for Legal Metrology (Organization International de Metrology Legal)

4 - Contact point

5 - Codex Alimentarius commission

کمیسیون فنی تدوین استاندارد

" ماشین آلات و تجهیزات ساختمان سازی - مخلوط کن های بتون -
قسمت دوم : روبه آزمایش بازده مخلوط کنی "

رئیس:

برقعی، علی محمد

(دکترای مهندسی ماشین های کشاورزی)

سمت و/یا نمایندگی

دانشگاه تهران - دانشکده کشاورزی - عضو هیئت علمی

دبیران:

خوشحال ، هادی

(لیسانس مهندسی شیمی)

شاه محمودی، بهزاد

(لیسانس فیزیک)

مؤسسه استاندارد و تحقیقات صنعتی ایران

مؤسسه استاندارد و تحقیقات صنعتی ایران

اعضا:

اعتمادی، محمود

(لیسانس مهندسی مکانیک)

امیر شاهی، سید مهدی

(فوق لیسانس مهندسی ماشین های کشاورزی)

بحری ، فرخنده السادات

(فوق لیسانس مهندسی مکانیک)

تحریریان، سالار

(لیسانس مهندسی مکانیک)

شرافتی، کیهان

(فوق لیسانس مهندسی ماشین های کشاورزی)

شاه اویسی، پیمان

(لیسانس مهندسی صنایع)

شرکت بازرسی فنی فلات پژواک

مؤسسه استاندارد و تحقیقات صنعتی ایران

فرهادی ، افشین

(فوق لیسانس مهندسی محیط زیست)

کاظمی، رضا

(فوق لیسانس مهندسی مکانیک)

کیانی، رضا

(فوق لیسانس مهندسی مکانیک)

لشگری، امید رضا

(فوق لیسانس مهندسی مکانیک)

مریخ، فرشید

(فوق لیسانس مکانیک ماشینهای کشاورزی)

مهدی زاده، علی

(لیسانس مهندسی مکانیک)

شرکت بازرسی فنی بهستون صنعت نوین

کارشناس

شرکت توسعه خودرو کار

وزارت جهاد کشاورزی - مؤسسه تحقیقات جنگلها و مراتع

کشور

پژوهشکده توسعه تکنولوژی جهاد دانشگاهی

پیش گفتار

استاندارد " ماشین آلات و تجهیزات ساختمان سازی - مخلوط کن های بتون - قسمت دوم : رویه آزمایش بازده مخلوط کنی " که پیش نویس آن توسط بنیاد آموزش های فنی و حرفه ای ایرانیان و بر اساس راهنمای ۲۱ ایزو " پذیرش منطقه ای یا ملی استاندارد های بین المللی و دیگر مدارک استاندارد " در کمیسیون های مربوطه تهیه و تدوین شده و در سیصد و چهل و هفتمین اجلاس کمیته ملی استاندارد خودرو و نیرو محرکه مورخ ۱۳۸۷/۷/۲۱ مورد تصویب و پذیرش قرار گرفته است ، اینک به استناد بند یک ماده ۳ قانون اصلاح قوانین و مقررات موسسه استاندارد و تحقیقات صنعتی ایران مصوب بهمن ماه ۱۳۷۱ به عنوان استاندارد ملی ایران منتشر می گردد .

برای حفظ همگامی و هماهنگی با تحولات و پیشرفت های ملی و جهانی در زمینه صنایع ، علوم و خدمات ، استاندارد های ملی ایران در مواقع لزوم تجدید نظر خواهد شد و هر پیشنهادی که برای اصلاح یا تکمیل این استاندارد ها ارائه شود ، در هنگام تجدید نظر در کمیسیون فنی مربوط مورد توجه قرار خواهد گرفت . بنابر این همواره از آخرین تجدید نظر آنها استفاده می گردد .

در تدوین این استاندارد ملی ایران ، استاندارد زیر به صورت الزام آور مورد ارجاع قرار گرفته است :

ISO 18650-2:2006, Building construction machinery and equipment — Concrete mixers —Part 2:Procedure for examination of mixing efficiency

ماشین آلات و تجهیزات ساختمان سازی – مخلوط کن های بتون – قسمت دوم : رویه آزمایش بازده مخلوط کنی

۱ هدف و دامنه کاربرد

هدف از تدوین این استاندارد ، تعیین رویه ها و الزامات مربوط به بررسی راندمان مخلوط کردن حاصل از مخلوط کن های نوع وعده ای^۱ (ناپیوسته) و نوع جریان پیوسته^۲ تعریف شده در استاندارد ISO 18650-1، می باشد.

این استاندارد برای مخلوط کن های بتون دارای ظرفیت اسمی بیشتر یا مساوی با 70/50 کاربرد دارد.

۲ مراجع الزامی

مراجع الزامی زیر حاوی مقرراتی است که در متن این استاندارد ملی ایران به آن ها ارجاع داده شده است . بدین ترتیب آن مقررات ، جزئی از این استاندارد محسوب میشود . در صورتی که به مدارکی با ذکر تاریخ انتشار ارجاع داده شده باشد ، اصلاحیه ها و تجدیدنظرهای بعدی آن مورد نظر این استاندارد ملی ایران نیست . در مورد مدارکی که بدون ذکر تاریخ انتشار به آن ها ارجاع داده شده است، همواره آخرین تجدیدنظر و اصلاحیه های بعدی آن ها مورد نظر است.

استفاده از مراجع زیر برای کاربر این استاندارد الزامی است :

- 2-1 ISO 1920-3, Testing of concrete — Part 3: Making and curing test specimens
- 2-2 ISO 2736-1, Concrete tests — Test specimens — Part 1: Sampling of fresh concrete
- 2-3 ISO 2736-2, Concrete tests — Test specimens — Part 2: Making and curing of test specimens for strength tests
- 2-4 ISO 3310-1, Test sieves — Technical requirements and testing — Part 1: Test sieves of metal wire cloth
- 2-5 ISO 4012, Concrete — Determination of compressive strength of test specimens
- 2-6 ISO 4109, Fresh concrete — Determination of the consistency — Slump test
- 2-7 ISO 4848, Concrete — Determination of air content of freshly mixed concrete — Pressure method
- 2-8 ISO 6783, Coarse aggregates for concrete — Determination of particle density and water absorption — Hydrostatic balance method
- 2-9 ISO 7033, Fine and coarse aggregates for concrete — Determination of the particle mass-per-volume and water absorption — Pycnometer method
- 2-10 ISO 11375, Building construction machinery and equipment — Terms and definitions
- 2-11 ISO 18650-1, Building construction machinery and equipment — Concrete mixers — Part 1: Vocabulary and general specifications

^۱-Batch-type

^۲-Continuous-type

۳ اصطلاحات و تعاریف

در این استاندارد اصطلاحات و تعاریف ارائه شده در استاندارد های ISO 11375 و ISO 18650-1 به کار می رود.

چکیده

چکیده موضوعات مطرح شده در این استاندارد به شرح زیر است:

- در بند ۴ الزامات تصدیق مخلوط کن مشخص شده است .
 - در بند ۵ روش آزمون عملکرد مخلوط کردن شامل کلیات، آماده ساز مخلوط بتون، نمونه برداری، و آزمون های مغایرت مشخص شده است .
 - در بند ۶ نحوه ارزیابی نتایج آزمون مشخص شده است .
 - در بند ۷ چگونگی و نمونه گزارش آزمون مشخص شده است.
 - در بند ۸ نحوه اظهار نهایی شامل نسبت پر شدن مخلوط کن آزمون شده و زمان بهینه مخلوط کردن مشخص شده است .
- سایر بندهای استاندارد بین المللی ISO 18650-2:2006 در مورد این استاندارد ملی الزامی می باشد.

First edition
2006-04-15

Corrected version
2006-08-15

**Building construction machinery and
equipment — Concrete mixers —**

**Part 2:
Procedure for examination of mixing
efficiency**

*Machines et matériels pour la construction des bâtiments — Malaxeurs
de béton —*

*Partie 2: Mode opératoire pour la détermination de l'efficacité de
malaxage*



Reference number
ISO 18650-2:2006(E)

© ISO 2006

PDF disclaimer

This PDF file may contain embedded typefaces. In accordance with Adobe's licensing policy, this file may be printed or viewed but shall not be edited unless the typefaces which are embedded are licensed to and installed on the computer performing the editing. In downloading this file, parties accept therein the responsibility of not infringing Adobe's licensing policy. The ISO Central Secretariat accepts no liability in this area.

Adobe is a trademark of Adobe Systems Incorporated.

Details of the software products used to create this PDF file can be found in the General Info relative to the file; the PDF-creation parameters were optimized for printing. Every care has been taken to ensure that the file is suitable for use by ISO member bodies. In the unlikely event that a problem relating to it is found, please inform the Central Secretariat at the address given below.

© ISO 2006

All rights reserved. Unless otherwise specified, no part of this publication may be reproduced or utilized in any form or by any means, electronic or mechanical, including photocopying and microfilm, without permission in writing from either ISO at the address below or ISO's member body in the country of the requester.

ISO copyright office
Case postale 56 • CH-1211 Geneva 20
Tel. + 41 22 749 01 11
Fax + 41 22 749 09 47
E-mail copyright@iso.org
Web www.iso.org

Published in Switzerland

Contents

Page

Foreword.....	iv
Introduction	v
1 Scope	1
2 Normative references	1
3 Terms and definitions.....	2
4 Requirements for mixer verified.....	2
5 Mixing performance test	2
5.1 General.....	2
5.2 Concrete mix preparation	3
5.3 Sampling.....	3
5.4 Variance tests	9
6 Evaluation of test results	13
7 Test report	13
8 Final remarks.....	17
8.1 Filling ratio of tested mixer.....	17
8.2 Optimization of mixing time.....	17
Bibliography	19

Foreword

ISO (the International Organization for Standardization) is a worldwide federation of national standards bodies (ISO member bodies). The work of preparing International Standards is normally carried out through ISO technical committees. Each member body interested in a subject for which a technical committee has been established has the right to be represented on that committee. International organizations, governmental and non-governmental, in liaison with ISO, also take part in the work. ISO collaborates closely with the International Electrotechnical Commission (IEC) on all matters of electrotechnical standardization.

International Standards are drafted in accordance with the rules given in the ISO/IEC Directives, Part 2.

The main task of technical committees is to prepare International Standards. Draft International Standards adopted by the technical committees are circulated to the member bodies for voting. Publication as an International Standard requires approval by at least 75 % of the member bodies casting a vote.

Attention is drawn to the possibility that some of the elements of this document may be the subject of patent rights. ISO shall not be held responsible for identifying any or all such patent rights.

ISO 18650-2 was prepared by Technical Committee ISO/TC 195, *Building construction machinery and equipment*, Subcommittee SC 1, *Machinery and equipment for concrete work*.

ISO 18650 consists of the following parts, under the general title *Building construction machinery and equipment — Concrete mixers*:

- *Part 1: Vocabulary and general specifications*
- *Part 2: Procedure for examination of mixing efficiency*

This corrected version of ISO 18650-2:2006 incorporates the following corrections:

- the second formula in 5.1;
- the cross-reference to 5.4.1.1 has been corrected to “e)” in the line describing m_s in 5.4.1.3;
- subscript “m” in Table 4, 18, has been deleted from variable V in the equation for G ;
- other minor editorial corrections have been made.

Introduction

This part of ISO 18650 deals with the testing of the mixing capabilities of concrete mixers, characterized as the recommended mixing time.

The test consists of the determination of the variance of the mortar, coarse aggregate and air content, and the consistency of concrete mix samples, drawn after an assumed mixing time.

Compressive strength is also tested.

The measure of a concrete mixer's efficiency is the value of the variance of the above parameters, after the assumed mixing time.

This part of ISO 18650 provides for the preparation of concrete mix, sampling, execution of particular tests, criteria of test result evaluation and the test report.

Building construction machinery and equipment — Concrete mixers —

Part 2: Procedure for examination of mixing efficiency

1 Scope

This part of ISO 18650 specifies the procedure and requirements for examination of the mixing efficiency of batch-type and continuous-type concrete mixers as defined in ISO 18650-1. It is applicable to concrete mixers having a rated capacity greater than or equal to 70/50.

2 Normative references

The following referenced documents are indispensable for the application of this document. For dated references, only the edition cited applies. For undated references, the latest edition of the referenced document (including any amendments) applies.

ISO 1920-3, *Testing of concrete — Part 3: Making and curing test specimens*

ISO 2736-1, *Concrete tests — Test specimens — Part 1: Sampling of fresh concrete*

ISO 2736-2, *Concrete tests — Test specimens — Part 2: Making and curing of test specimens for strength tests*

ISO 3310-1, *Test sieves — Technical requirements and testing — Part 1: Test sieves of metal wire cloth*

ISO 4012, *Concrete — Determination of compressive strength of test specimens*

ISO 4109, *Fresh concrete — Determination of the consistency — Slump test*

ISO 4848, *Concrete — Determination of air content of freshly mixed concrete — Pressure method*

ISO 6783, *Coarse aggregates for concrete — Determination of particle density and water absorption — Hydrostatic balance method*

ISO 7033, *Fine and coarse aggregates for concrete — Determination of the particle mass-per-volume and water absorption — Pycnometer method*

ISO 11375, *Building construction machinery and equipment — Terms and definitions*

ISO 18650-1, *Building construction machinery and equipment — Concrete mixers — Part 1: Vocabulary and general specifications*

3 Terms and definitions

For the purposes of this document, the terms and definitions given in ISO 18650-1 and ISO 11375 apply.

4 Requirements for mixer verified

The design and execution of the whole structure of the mixer and its components, such as the mixing chamber (drum, pan, or trough), rotor with blades or paddle agitator(s), their directions of rotation, charging and discharging devices (if any), should be verified according to the manufacturer's instructions.

It shall be determined that the number of revolutions per minute of a drum or mixing tools conforms to the manufacturer's specification.

The drive system should be able to restart 5 min after being stopped when the mixer has completed the mixing of the test batch as specified in 5.2.1.

The mixer shall be discharged according to its design or as specified by the manufacturer. The closure of the mixing chamber shall be so designed that the loss of the mix before discharge, i.e. during charging and mixing, remains below 0,5 %.

5 Mixing performance test

5.1 General

The mixing efficiency is determined by the uniformity of the concrete mix and the compressive strength of the concrete cubes or cylinders, sampled after mixing time. The determination of the uniformity of the concrete mix includes the following variance tests on the sampled specimens:

- a) air content;
- b) content of mortar per unit volume;
- c) content of coarse aggregate per unit volume;
- d) consistency (slump).

The values of the concrete-mix component content (air, mortar, coarse aggregate), determined as the test results, as well as the consistency and compressive strength, are subsequently used for calculation of their variances.

For calculating the variance, ΔX , of the considered components' content and other features, expressed as a percentage, the following formula is applied:

$$\Delta X = \frac{X_1 - X_2}{X_1 + X_2} \times 100$$

where

- X_1 is the value of component content, slump and compressive strength received from portion 1 or 2 — larger value of X_1 and X_2 ;
- X_2 is the value of component content, slump and compressive strength received from portion 1 or 2 — smaller value of X_1 and X_2 .

To explain the physical sense of this formula, it can be transformed as follows:

$$\Delta X = \frac{X_1 - X_2}{X_1 + X_2} = \frac{\frac{X_1 + X_2}{2} - X_2}{\frac{X_1 + X_2}{2}}$$

In this form it represents the variance of a subject parameter in two portions against its average value.

For evaluation of the test results, the particular variance values are compared with the acceptable results according to Clause 6.

5.2 Concrete mix preparation

The test concrete to be used for the mixing performance test should be specified by the concrete manufacturer or testing laboratory with the following conditions: coarse aggregates up to 20 mm, slump (80 ± 30) mm, air content $(4,5 \pm 1,5)$ % and nominal compressive strength (25 ± 5) N/mm². In case of difficulty in obtaining of the assumed air content, an appropriate admixture may be used.

The quantity of materials usually corresponds to the rating capacity declared by the mixer's manufacturer.

The constituent materials shall be weighed within measuring accuracy limits of ± 3 %.

The sequence of a mixer charging with particular components should be as specified in the manufacturer's instruction. If there is no such instruction, the method of charging should be noted in the test report.

The charging of a mixer with constituent materials shall be carried out with a minimum loss of materials.

The mixing time shall be as specified by the manufacturer. If no such specification is available, the following approximate values — depending on the mixer type and its capacity — are recommended:

a) For batch-type gravity mixers:

- rated capacity 1,0 m³ and less, 60 s;
- rated capacity above 1,0 m³, 5 s added to 60 s for every 0,5 m³ increase.

b) For batch-type compulsory mixers:

- rated capacity 3,0 m³ and less, 30 s;
- rated capacity above 3,0 m³, 15 s added to 30 s for every 1,5 m³ increase.

c) For continuous mixers: a mixing time corresponding to the duration of the concrete mix in the mixing chamber, which shall be at least 10 s.

5.3 Sampling

5.3.1 General

Two portions of the concrete mix are sampled directly from the mixing chamber immediately after assured mixing time (see Figures 2, 3, 4 and 5). Where the direct sampling from inside the mixing chamber is difficult, the sampling may be done from the concrete mix discharged to the hopper (see Figures 6 and 7). The volume of the sample (portion) should be a minimum of 20 l for batch mixers and 100 l for continuous mixers (see 5.3.4). Afterwards, the specimens for particular variance tests are prepared.

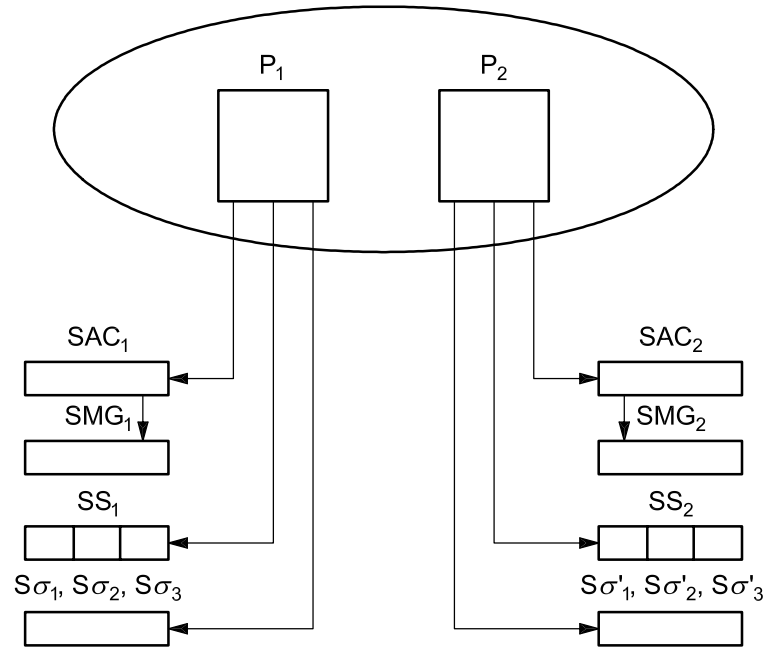

Key

- P₁, P₂ concrete mix portion sampled from the mixer
- SAC₁, SAC₂ specimens for air content test
- SMG₁, SMG₂ specimens for air content test used for coarse aggregate and mortar content testing in further sequence
- Sσ₁, Sσ₂, Sσ₃, Sσ'₁, Sσ'₂, Sσ'₃ specimens for compressive strength test (three cubes or cylinders from each portion)
- SS₁, SS₂ specimens for consistency (slump) test

Figure 1 — General scheme of sampling

5.3.2 Batch-type compulsory mixers

5.3.2.1 Pan-type mixers

In pan-type mixers the samples (portions) are taken from concentric circles. Figure 2 shows an example of sampling in a turbo mixer.

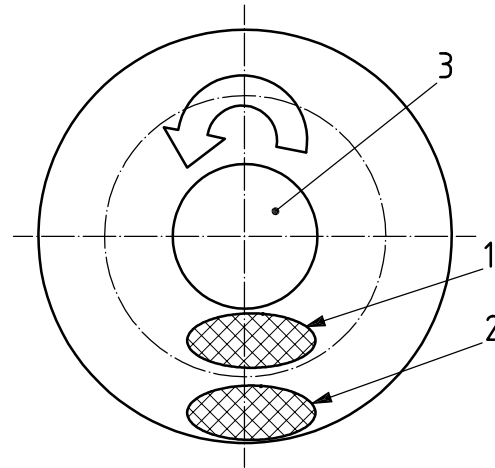
**Key**

- 1 centre portion
- 2 edge portion
- 3 centre cylinder covering dead mixing area

Figure 2 — Sampling in turbo mixer

In other types of pan-type mixers, those not having a centre cylinder covering the dead mixing area, the radius separating two concentric circles is equal to a quarter of the inner pan diameter.

5.3.2.2 Paddle mixers

Examples of sampling in paddles mixers with one or two paddle agitators are shown in the Figure 3.

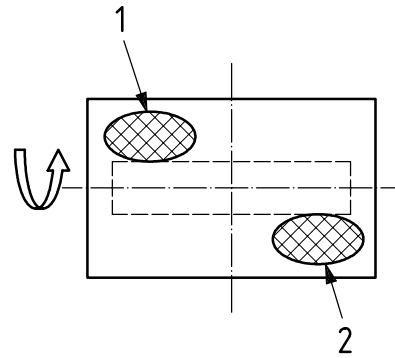

a) One-agitator mixer

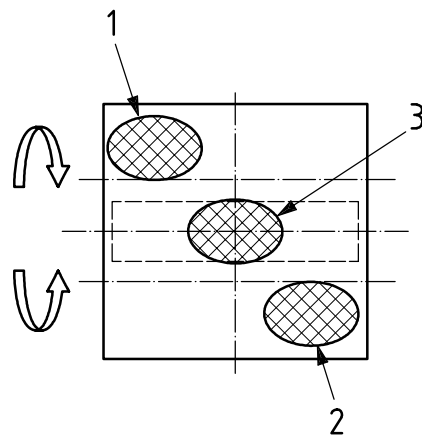

b) Two-agitator mixer

Key

- 1 front portion
- 2 rear portion
- 3 centre portion

Figure 3 — Sampling in paddle-type mixer

5.3.3 Gravity mixers

The concrete mix portions are taken to the receiving containers from the beginning and end of the concrete discharge stream, as shown in Figure 4.

A batch during discharging is divided for convenience into three parts (beginning, middle and end), from which the corresponding portions are taken.

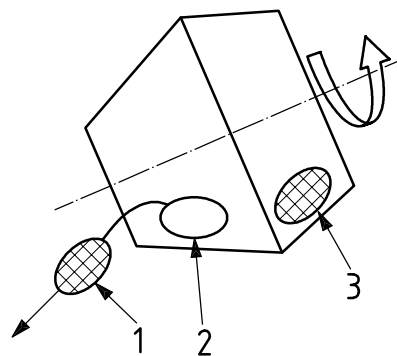

a) Tipping drum mixer

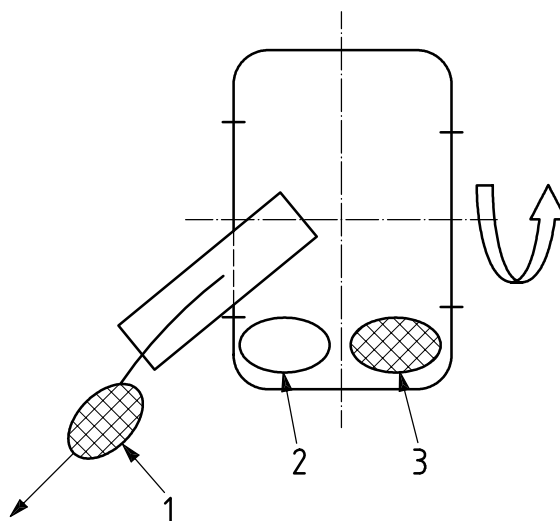

b) Discharging chute drum mixer

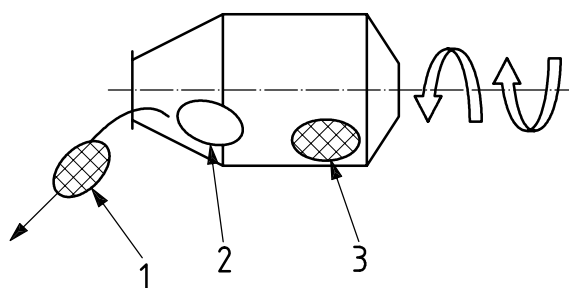

c) Reversing drum mixer

Key

- 1 beginning portion
- 2 middle portion
- 3 end portion

Figure 4 — Sampling in gravity mixers

5.3.4 Continuous mixers

The first-sampled portion should be from a stable flow, just at the moment when the discharged concrete reaches output capacity, with another sample being taken 4 min after the first. The volume of each portion should be at least 100 l.

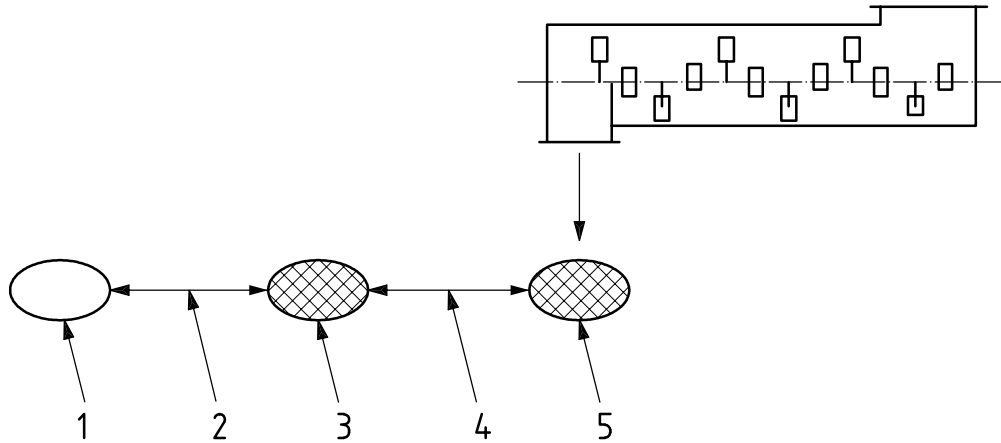

Key

- 1 missed, initial quantity concrete mix until stable delivery achieved
- 2 break minimum 0,5 min
- 3 first portion
- 4 break minimum 4 min
- 5 second portion

Figure 5 — Sampling in continuous mixer

5.3.5 Sampling from concrete mix hopper

If there is no method of sampling directly from a mixing chamber, the portions may be taken from the concrete mix hopper. The scheme of sampling is shown in Figure 6.

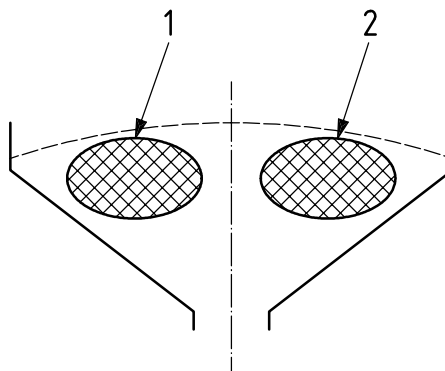

Key

- 1 left portion
- 2 right portion

Figure 6 — Sampling from concrete mix hopper

5.4 Variance tests

5.4.1 Variance of air, mortar and coarse aggregate content in concrete mix

5.4.1.1 Test procedure

Perform the following procedure (see Figures 1 and 7).

- a) Take one concrete mix specimen from each portion.
- b) Determine the air content, A_1 and A_2 , of the specimens, using the pressure method in accordance with ISO 4848 (see 5.4.1.2).

With the same test specimens — following the air content determination — determine the mortar and coarse aggregate content as follows.

- c) Measure the masses, m , of the specimens.
- d) Remove all particles in the specimens by washing on either a 4 mm or 5 mm screen in accordance with ISO 3310-1.
- e) Determine the mass of coarse aggregate.

Calculate the aggregate masses as follows:

- the mass of coarse aggregate remaining on the screen in the saturated surface-dry condition (m_s);
- the density of coarse aggregate in the saturated surface-dry condition (D_s), in accordance with the test methods for particle mass-per-volume and water absorption given in ISO 6783 and ISO 7033;
- the virtual mass of coarse aggregate remaining on the screen in water (m_w).

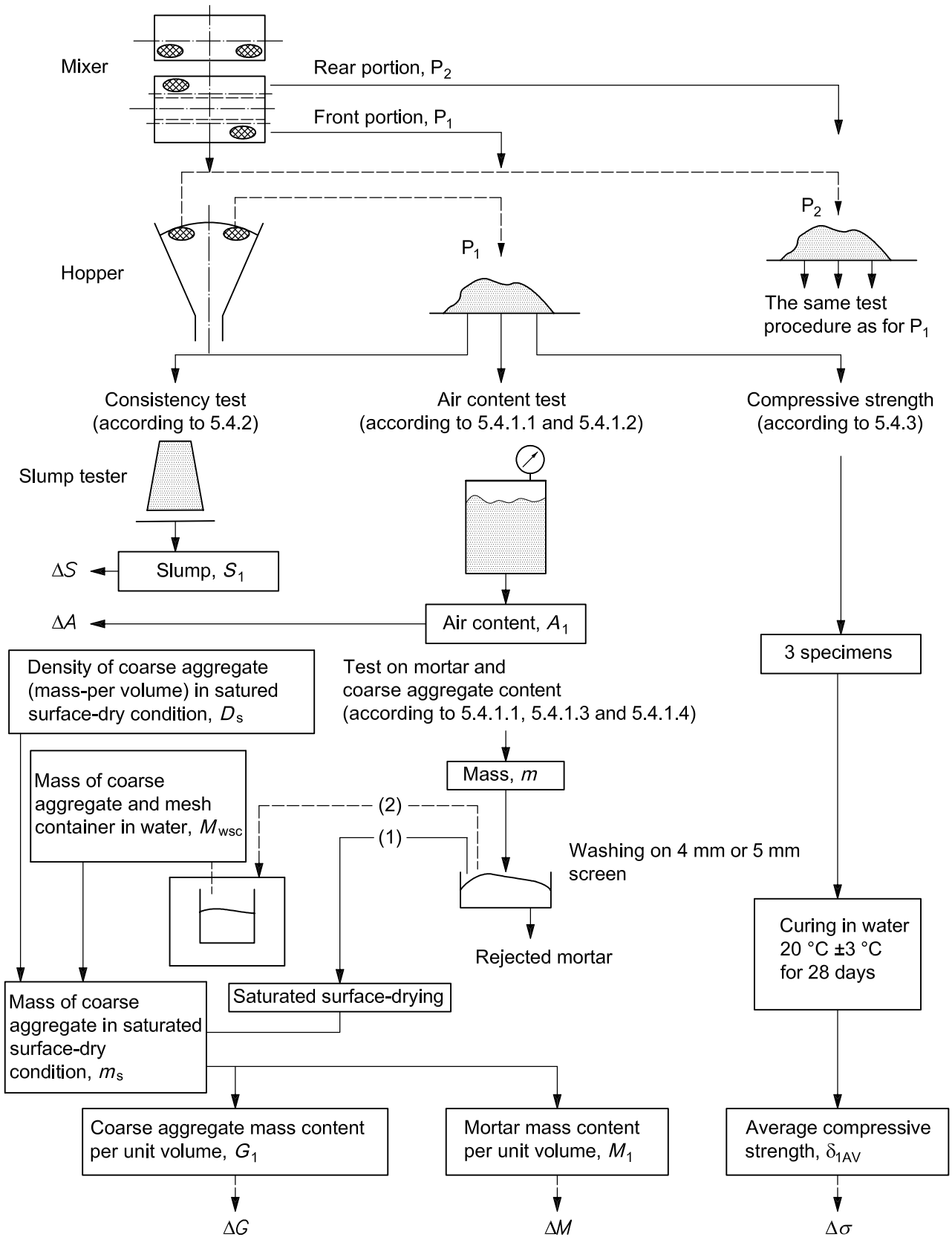

NOTE There are two alternative methods of coarse aggregate volume measurement:
 — saturated surface-dry method (m_s), (1) in the figure, or
 — calculation from mass of coarse aggregates in water (m_w), (2) in the figure.

Figure 7 — Example of testing procedure for two-agitator paddle mixer and hopper use

5.4.1.2 Calculation of air content variance

For the air content test of the concrete mix, take two test specimens according to 5.3.1 and test according to ISO 4848; their variance, ΔA , from the average value, is calculated as a percentage using the formula:

$$\Delta A = \frac{A_1 - A_2}{A_1 + A_2} \times 100$$

where

A_1 is the air content value of specimen SAC₁ (see Figure 1);

A_2 is the air content value of specimen SAC₂ (see Figure 1).

In the case where $A_2 > A_1$, the absolute value of ΔA should be taken.

5.4.1.3 Calculation of mortar content variance

The mass of mortar per unit volume without air, M , per unit volume of concrete mix, is calculated in kilograms per cubic metre (kg/m³) using the formula:

$$M = \frac{m - m_s}{V - \left(V_A + \frac{m_s}{D_s} \right)} \times 1000$$

where

m is the mass of the concrete mix, in kilograms (kg) [see 5.4.1.1, c)];

m_s is the mass of coarse aggregate remaining on the 4 mm or 5 mm mesh screen in saturated surface-dry condition (kg) [see 5.4.1.1, e)];

V is the volume of the container, in litres (l), used in the air content test according to ISO 4848 [see 5.4.1.1, b)];

V_A is the volume of air in litres (l) calculated from the volume (V) of the container, multiplied by the air content ratio (%) divided by 100;

D_s is the density of coarse aggregate (particle mass-per-volume) in saturated surface-dry condition, in kilograms per litre (kg/l).

The mass of coarse aggregate, m_s , remaining on the 4 mm or 5 mm mesh screen after the virtual mass of coarse aggregate in the water has been measured is calculated using

$$m_s = m_w \times \frac{D_s}{D_s - 1}$$

where

m_w is the mass of coarse aggregate in the water (kg);

D_s is the density of the coarse aggregate (particle mass-per-volume) in saturated surface-dry condition (kg/l).

The unit mass variance, ΔM , of mortar in concrete mix is then calculated, as a percentage, using

$$\Delta M = \frac{M_1 - M_2}{M_1 + M_2} \times 100$$

where

M_1 is the mortar content of specimen SMG_1 (see Figure 1);

M_2 is the mortar content of specimen SMG_2 (see Figure 1).

In the case where $M_2 > M_1$, the absolute value of ΔM should be taken.

5.4.1.4 Calculation of coarse aggregate mass variance

Coarse aggregate mass, G , in saturated surface-dry condition per unit volume is calculated in kilograms per cubic metre (kg/m^3) using the formula:

$$G = \frac{m_s}{V} \times 1000$$

where m_s and V are as given in 5.4.1.3.

Coarse aggregate mass variance, ΔG , in the concrete mix, expressed as a percentage, is then calculated using

$$\Delta G = \frac{G_1 - G_2}{G_1 + G_2} \times 100$$

where

G_1 is the coarse aggregate content of specimen SMG_1 (see Figure 1);

G_2 is the coarse aggregate content of specimen SMG_2 (see Figure 1).

In the case where $G_2 > G_1$, the absolute value of ΔG should be taken.

5.4.2 Consistency test

Verify the consistency of two specimens taken according to 5.3.1 by the slump test, using the method specified in ISO 4109; their variance, ΔS , from the average value is then calculated as a percentage using the formula:

$$\Delta S = \frac{S_1 - S_2}{S_1 + S_2} \times 100$$

where

S_1 is the slump value of specimen SS_1 (see Figure 1);

S_2 is the slump value of specimen SS_2 (see Figure 1).

In the case where $S_2 > S_1$, the absolute value of ΔS should be taken.

5.4.3 Compressive strength test

For the compressive strength test, take three specimens from each portion (see Figures 1 and 7) and prepare in accordance with ISO 1920-3 and ISO 2736-1. Perform the test in accordance with ISO 4012. The curing method of these specimens shall be in accordance with ISO 2736-2, with a curing period of 28 days.

The average compressive strengths, σ_{1AV} and σ_{2AV} , for particular portions are then calculated for portion 1 and portion 2, respectively using the formulae:

$$\sigma_{1AV} = \frac{\sigma_1 + \sigma_2 + \sigma_3}{3}$$

$$\sigma_{2AV} = \frac{\sigma'_1 + \sigma'_2 + \sigma'_3}{3}$$

where

$\sigma_1, \sigma_2, \sigma_3$ is the compressive strength of specimens $S\sigma_1, S\sigma_2, S\sigma_3$, taken from portion 1;

$\sigma'_1, \sigma'_2, \sigma'_3$ is the compressive strength of specimens $S\sigma'_1, S\sigma'_2, S\sigma'_3$, taken from portion 2.

Compressive strength variance $\Delta\sigma$ is calculated using

$$\Delta\sigma = \frac{\sigma_{1AV} - \sigma_{2AV}}{\sigma_{1AV} + \sigma_{2AV}} \times 100$$

In the case where $\sigma_{2AV} > \sigma_{1AV}$, the absolute value of $\Delta\sigma$ should be taken.

6 Evaluation of test results

With the aim of mixing time acceptance, the variance of the concrete mix component content proportions, the consistency and the compressive strength of the concrete cubes or cylinders shall be in accordance with Table 1.

Table 1 — Uniformity requirement

No.	Type of test	Acceptable variance value %
1	Air content variance ΔA in concrete mix (see 5.4.1.2)	≤ 10
2	Mortar (≤ 5 mm) content variance ΔM in concrete mix (see 5.4.1.3)	$\leq 0,8$
3	Coarse aggregate (> 5 mm) content variance ΔG in concrete mix (see 5.4.1.4)	≤ 5
4	Consistency (slump) variance ΔS (see 5.4.2)	≤ 15
5	Compressive strength variance $\Delta\sigma$ (see 5.4.3)	$\leq 7,5$

7 Test report

After the tests are concluded, a test report should be prepared. The format of the report should be according to Tables 2, 3 and 4. Tables 2 and 3 present data on the tested concrete mixer and the concrete mix preparation, while Table 4 presents the numerical values of the particular tests.

Table 2 — Batch type concrete mixer — Data on mixer and concrete mix preparation

Requested by:				
Type of mixer:				
Product plate information:				
Manufacturer:				
Dry components/ready concrete capacities (dm ³)	Type	Serial number	Year of manufacture	Power source output (kW)
Remarks for mixing conditions (see 5.2)				
Mixing procedure				
Mixing conditions	Test concrete			
	Sample mixture 1	Sample mixture 2		
Mixed volume — ready concrete (dm ³)				
Filling ratio(Mixed volume by nominal capacity) (%)				
Drum, number of revolution (min ⁻¹)				
Shaft, number of revolution (min ⁻¹)				
Charging time t_1 (s)				
Mixing time t_2 (s)				
Discharging time t_3 (s)				
Resetting time t_4 (s)				
Cycle time $t_s = t_1 + t_2 + t_3 + t_4$ (s)				
Remarks				
Test place:	Test date:	Test report:		
Name and address of test facility:				
Test report date:				
Tested by (signature):				

Table 3 — Continuous concrete mixer — Data on mixer and concrete mix preparation

Requested by:				
Type of mixer:				
Product plate information:				
Manufacturer:				
Output capacity m ³ /h	Type	Serial number	Year of manufacture	Power source output (kW)
Remarks for mixing conditions				
Mixing procedure				
Mixing conditions		Test concrete		
		Sample mixture 1	Sample mixture 2	
Mixing capacity – ready concrete (m ³ /h)				
Sampling time (s)				
Drum, number of revolution (min ⁻¹)				
Shaft, number of revolution (min ⁻¹)				
Inclination of the axis of the mixing chamber (°)				
Remarks				
Test place:		Test date:	Test report:	
Name and address of test facility:				
Test report date:				
Tested by (signature)				

Table 4 — Report on the results of the concrete mixer and concrete tests

Test date											
Mixer type		Mixing time						s			
Rating capacity		m ³				Mixing volume/ready concrete				m ³	
Test concrete											
Nominal strength (N/mm ²)	Slump (cm)	Aggregate max. size (mm)	Air content (%)	Water/Cement ratio (%)	Fine aggregate ratio (%)	Content (kg/m ³)					
						W	C	S	G	Ad	
Test procedure						Sample 1		Sample 2			
1	Test specimen slump			<i>S</i>	(cm)						
2	Test specimen air content			<i>A</i>	(%)						
3	Mass of the specimen with its container			<i>M_{sc}</i>	(kg)						
4	Mass of said container			<i>M_c</i>	(kg)						
5	Mass of the specimen			$m = M_{sc} - M_c$	(kg)						
6	Container volume			<i>V</i>	(l)						
7	Air volume			$V_A = A \times V / 100$	(l)						
8	Specimen volume without air content			$V_{ss} = V - V_A$	(l)						
9	Mass of coarse aggregate with 4 or 5 mm mesh container in water			<i>M_{wsc}</i>	(kg)						
10	Mass of mesh container in water			<i>M_{wc}</i>	(kg)						
11	Mass of coarse aggregate in water			$m_w = M_{wsc} - M_{wc}$	(kg)						
12	Density of coarse aggregates in saturated surface-dry condition			<i>D_s</i>	(kg/l)						
13	Mass of coarse aggregate in saturated surface-dry condition			$m_s = m_w \times D_s / (D_s - 1)$	(kg)						
14	Absolute volume of a specimen sieved by 4 or 5 mm mesh			$V_{as} = m_w / (D_s - 1) = m_s / D_s$	(l)						
15	Content of mortar mass of the specimen			$M_m = m - m_s$	(kg)						
16	Mortar volume of the specimen			$V_m = V_{ss} - V_{as}$	(l)						
17	Mortar mass content per unit volume			$M = 1\,000 \times M_m / V_m$	(kg/l)						
18	Coarse aggregates mass content per unit volume			$G = 1\,000 \times m_s / V$	(kg/l)						
19	Capacity mass variance of mortar in concrete mix			ΔM	(%)						
20	Coarse aggregates variance in concrete mix			ΔG	(%)						
21	Slump variance from average			ΔS	(%)						
22	Air content variance from average			ΔA	(%)						
23	Compressive strength of specimens:			$\sigma_1, \sigma_2, \sigma_3$	(N/mm ²)						
				$\sigma'_1, \sigma'_2, \sigma'_3$	(N/mm ²)						
24	Average compressive strength			$\sigma_{1AV}, \sigma_{2AV}$							
25	Variance from average strength			$\Delta \sigma_n$							
Test location:				Test date:							
Test report:				Name and address of test facility:							
Tested by (signature):				Test report date:							

8 Final remarks

8.1 Filling ratio of tested mixer

The quantity of components used for the test usually corresponds to the rated capacity of the mixer for batch-type mixers and the rating output for continuous mixers declared by the manufacturer. The procedure presented in this part of ISO 18650 makes it possible also to examine the mixing efficiency for smaller filling mixers' ratios and rating outputs.

8.2 Optimization of mixing time

For the manufacturers and users of the mixers, of most importance is to obtain the shortest (optimum) mixing time providing required concrete quality and maximum output from the equipment. To obtain this, it is necessary to execute the same test for different mixing times chosen on the results of the variance of resistance to compression ($\Delta\sigma$) obtained in the previous tests. The results of tests are marked on a graph as a function of the mixing time and the curve drawn by interpolation. An example of optimum mixing time determination based on compressive strength testing is presented in Figure 8.

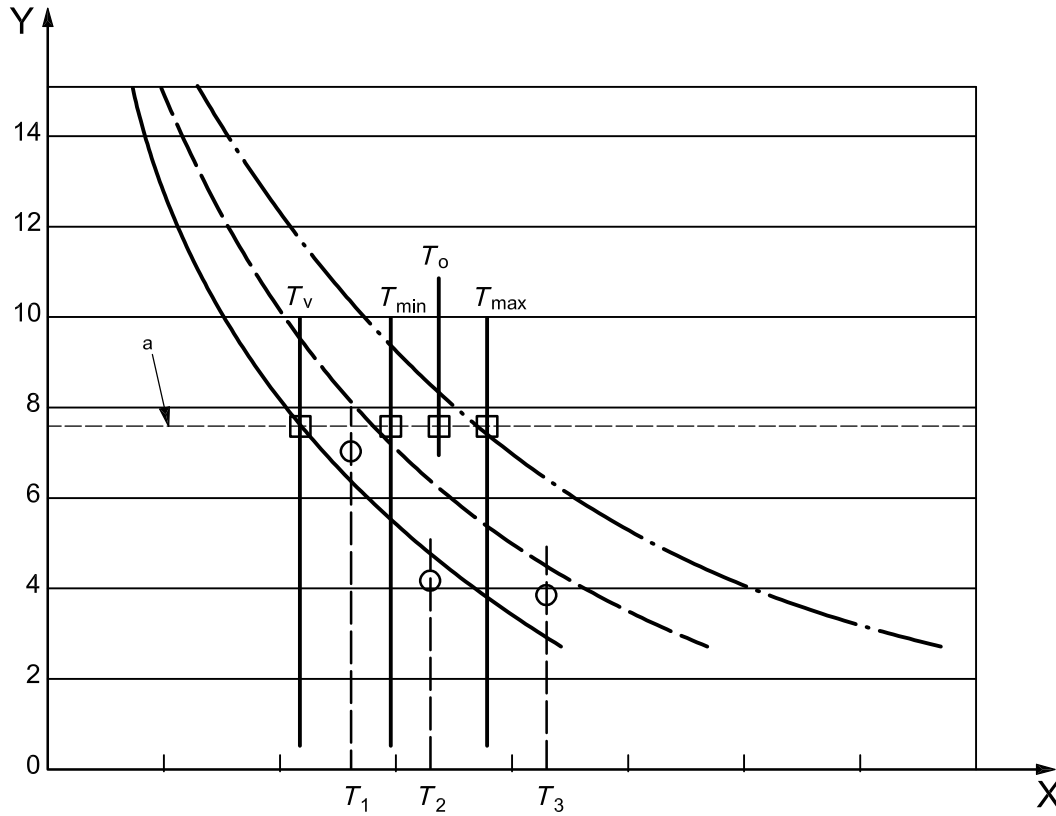

Key

- X mixing time (s)
- Y variance of resistance to compression, $\Delta\sigma$ (%)
- T_1 test time 1 for finding optimum mixing time and data point (○)
- T_2 test time 2 for finding optimum mixing time and data point (○)
- T_3 test time 3 for finding optimum mixing time and data point (○)

Regression curves:

- $\Delta\sigma + 1s$
- - - - - $\Delta\sigma + 2s$
- · - · - $\Delta\sigma + 3s$

where s is the standard deviation of $\Delta\sigma$

- T_v time at virtual intersection (□) between regression curve ($\Delta\sigma + 1s$) and limiting quality line: value of variation over acceptable value, with 68,26 % probability at this time and thus unacceptable
- T_{min} minimum allowable mixing time at data point (□) corresponding to intersection between regression curve ($\Delta\sigma + 2s$) and limiting quality line: value of variation acceptable with 95,44 % probability
- T_{max} maximum mixing time and data point (□) corresponding to intersection between regression curve ($\Delta\sigma + 3s$) and limiting quality line: value of variation adequate with 99,74 % probability

^a Acceptable limit, $\Delta\sigma = 7,5$ %.

NOTE The optimum mixing time, T_o (□) is such that $T_{min} \leq T_o < T_{max}$.

Figure 8 — Determination of the optimum mixing time

Bibliography

- [1] DIN 459-2, *Building material machines — mixer for concrete and mortar — Part 2: Procedure for examination of mixing efficiency of concrete mixers*
- [2] ISO 6274, *Concrete — Sieve analysis of aggregates*
- [3] ISO 6276, *Concrete compacted fresh — Determination of density*
- [4] ISO 6782, *Aggregates for concrete — Determination of bulk density*

